

## OIL TANKS

### CAPACITY FROM 80 LITERS TO 250 LITERS

# SIDE MOUNTING

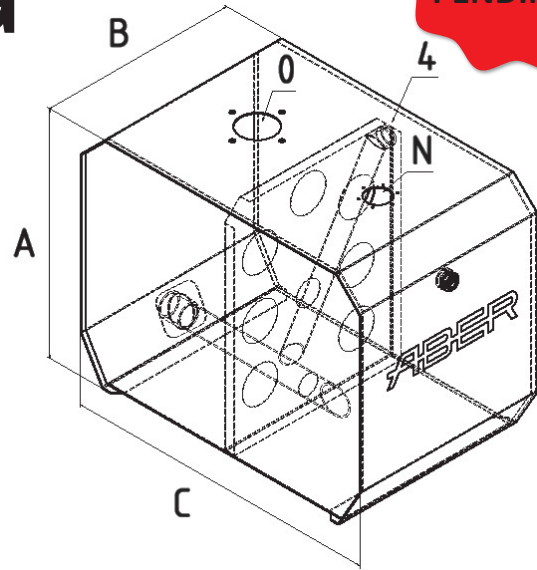
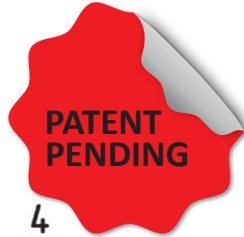

CAPACITY LITERS	MATERIAL	A mm	B mm	C mm	SUCTION PIPE " BSP
80	FE - AL - IX	510	290	640	1" 1/2
100	FE - AL - IX	510	350	640	1" 1/2
130	FE - AL - IX	550	360	710	1" 1/2
160	FE - AL - IX	550	450	710	1" 1/2
200	FE - AL - IX	550	560	710	1" 1/2
201	AL	620	500	710	1" 1/2
250	FE - AL - IX	550	700	710	1" 1/2

ON REQUEST MANY OTHER CONFIGURATIONS AND VOLUMES CAN BE PRODUCED. FOR NON STANDARD DIMENSIONS PLEASE CONTACT US.

## HOW TO ORDER

ON DARKER COLOR ARE THE USUALLY SELECTED OPTIONS

TSB + [ ] + [ ] + [ ] + [ ] + [ ] + [ ] + [ ]

MODEL	STANDARD CAPACITY	MATERIAL	LEVEL INDICATOR	FILLER AND BREATHER	MOUNTING OPTIONS				SUPPORT	OPTIONALS	
TSB	80L 100L 130L 160L 200L 250L	FE STEEL AL ALUMINIUM IX STAINLESS STEEL	R ROUND OIL LEVEL INDICATOR L LONG OPTICAL OIL LEVEL INDICATOR	N READY FOR FILLER CAP PLUG FB FILLER CAP BREATHING PLUG WITH INTEGRAL AIR FILTER	0 READY FOR TANK TOP OIL RETURN FILTER OR FLANGE FOR VALVE	1 TANK TOP OIL RETURN FILTER SINGLE PORT 1A TANK TOP OIL RETURN FILTER DOUBLE PORT	2 FLANGE TO PNEUMATIC DISTRIBUTOR AND OIL FILTER DISTRIBUTOR NOT INCLUDED	3 FLANGE TO ELECTRICAL DISTRIBUTOR AND OIL FILTER DISTRIBUTOR NOT INCLUDED	4 DIRECT OIL RETURN	S1 SIDE BELT SUPPORT S2 SIDE OR REAR BELT SUPPORT WITH THE SAME SUPPORTS IS POSSIBLE TO USE AS SIDE OR REAR MOUNTING	M MANOMETER FOR RETURN FILTER

EXAMPLE

### TSB 160 FE L FB 1 S1 M

Tank with 160 liters, Side Mounting with Brackets, made in Steel, with Long Optical Oil Level, Filler Cap with Integral Air Filter, Tank Top Return Filter (Single), and Side Belt Support with manometer

