

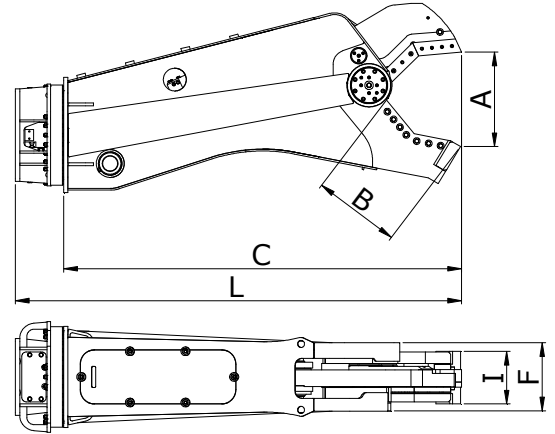

MC

Hydraulic Equipment Industries



MODELLO MODEL MODÈLE MODELL	PESO WEIGHT POIDS GEWICHT		FORZA FORCE FORCE KRAFT		DIMENSIONI (mm) SIZES (mm) DIMENSIONS (mm) ABMESSUNGEN (mm)					PRESSIONE PRESSURE PRESSION DRUCK	PORTATA OLIO REC OILFLOW DEBIT DURCHSATZ	TEMPI TIMES TEMPS ZEITE		PESO ESCAVATORE POSTO BRACCIO EXCAVATOR WEIGHT FIRST ARMPLACE POIDS PELLE PLACE BALANCIER	PESO ESCAVATORE POSTO BENNA EXCAVATOR WEIGHT BUCKET PLACE POIDS PELLE PLACE GODET
	Kg	t	A	B	C	L	I	F	bar			L/min	CLOSE sec.		
MC 290	280	110/40/30	290	260	1320	-	150	230	300	60/100	3,3/2,0	2,2/1,3	2 : 5	3 : 9	
MC 290 R	370	110/40/30	290	260	1320	1520	150	230	300	60/100	3,3/2,0	2,2/1,3	2 : 5	3 : 9	
MC 430	650	210/70/50	430	310	1790	-	180	250	320	100/130	5,4/4,2	2,8/2,2	5 : 9	8 : 14	
MC 430 R	810	210/70/50	430	310	1790	2250	180	250	320	100/130	5,4/4,2	2,8/2,2	5 : 9	8 : 14	
MC 570	1550	280/100/70	570	520	2400	-	310	420	350	180/250	3,2/2,3	2,3/1,6	12 : 16	18 : 27	
MC 570 R	1950	280/100/70	570	520	2400	2780	310	420	350	180/250	3,2/2,3	2,3/1,6	12 : 16	18 : 27	
MC 600	2200	380/160/90	600	550	2540	-	350	430	350	220/320	3,8/4,0	3,3/2,8	14 : 25	20 : 32	
MC 600 R	2600	380/160/90	600	550	2540	2920	350	430	350	220/320	3,8/4,0	3,3/2,8	14 : 25	20 : 32	
MC 660	2850	550/190/130	660	610	2830	-	370	480	350	250/350	5,6/4,0	4,0/3,8	20 : 28	30 : 40	
MC 660 R	3250	550/190/130	660	610	2830	3210	370	480	350	250/350	5,6/4,0	4,0/3,8	20 : 28	30 : 40	
MC 740 *	4500	700/280/160	740	680	3160	-	430	530	350	350/450	5,2/4,1	4,8/3,8	24 : 35	35 : 50	
MC 740 R *	5050	700/280/160	740	680	3160	3660	430	530	350	350/450	5,2/4,1	4,8/3,8	24 : 35	35 : 50	
MC 820 *	5600	850/280/240	820	760	3510	-	470	580	350	450/600	5,5/4,1	5,0/3,8	30 : 40	45 : 60	
MC 820 R *	6150	850/280/240	820	760	3510	4010	470	580	350	450/600	5,5/4,1	5,0/3,8	30 : 40	45 : 60	
MC 910 *	7100	1030/410/240	910	810	3900	-	520	670	350	500/800	6,5/4,1	6,0/3,8	42 : 55	65 : 80	
MC 910 R *	7650	1030/410/240	910	810	3900	4400	520	670	350	500/800	6,5/4,1	6,0/3,8	42 : 55	65 : 80	

* Drenaggio - Drainage - Drainage - Entwässerung



Call for advice on: 0844 770 7969 e-mail us: sales@approvedhydraulics.co.uk