

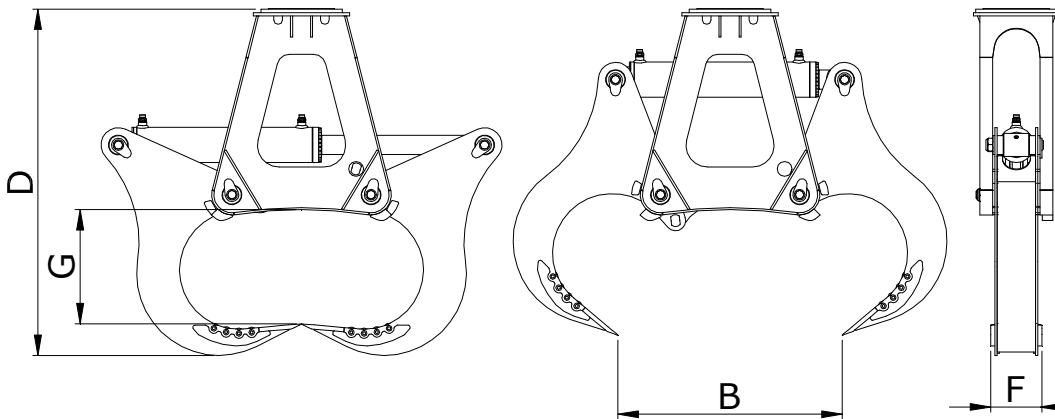

Hydraulic Equipment Industries

# MST



MODELLO MODEL MODÈLE MODELL	PESO WEIGHT POIDS GEWICHT	PRESSIONE PRESSURE PRESSION DRUCK	PORTATA OLIO REC OILFLOW DEBIT DURCHSATZ	CILINDRI CYLINDERS CYLINDRES ZYLINDER	FORZA (t) FORCE (t) FORCE (t) KRAFT (t)	DIMENSIONI (mm) SIZES (mm) DIMENSIONS (mm) ABMESSUNGEN (mm)				MACCHINA MACHINE MACHINE MASCHINE
	Kg	MAX-BAR	L/min C/A	N°	t	B	D	G	F	MAX-TON
MST 30	600	330	250-180	1	37.7	1050	1630	530	240	12-15
MST 40	1050	330	250-230	1	42.6	1360	1900	600	310	16-25



Call for advice on: 0844 770 7969 e-mail us: [sales@approvedhydraulics.co.uk](mailto:sales@approvedhydraulics.co.uk)