

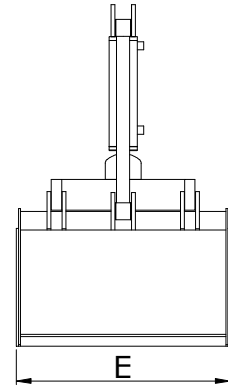

Hydraulic Equipment Industries

MBV

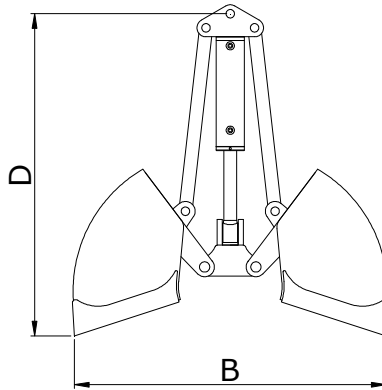
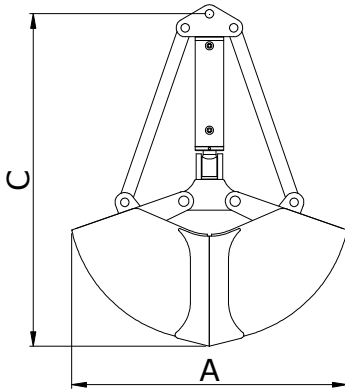

MODELLO MODEL MODÈLE MODELL	CAPACITA' CAPACITY CAPACITÉ INHALT	PRESSIONE PRESSURE PRESSION DRUCK	PESO WEIGHT POIDS GEWICHT	DENTI TEETH DENTS ZÄHNE	CILINDRI CYLINDERS CYLINDRES ZYLINDER	FORZA FORCE FORCE KRAFT	DIMENSIONI (mm) SIZES (mm) DIMENSIONS (mm) ABMESSUNGEN (mm)					MACCHINA MACHINE MACHINE MASCHINE
							LT	MAX-BAR	KG	n°	n°	
MBV 1	120	250	210	3	1	2.1	1075	1215	1295	1255	300	7-12
MBV 2	250	250	250	3	1	2.1	1075	1215	1295	1255	600	7-12
MBV 3	320	250	280	5	1	2.1	1075	1215	1295	1255	830	7-12
MBV 4	400	250	330	7	1	2.1	1075	1215	1295	1255	1000	7-12



Call for advice on: 0844 770 7969 e-mail us: sales@approvedhydraulics.co.uk