

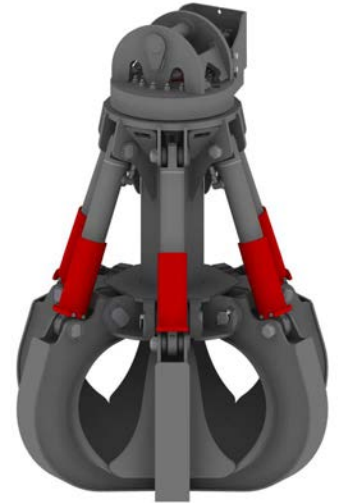

Hydraulic Equipment Industries

MPV - FHF

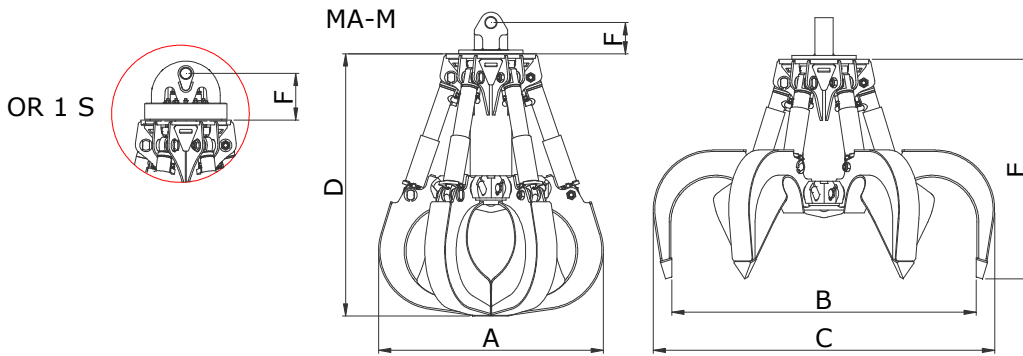

MODELLO MODEL MODÈLE MODELL	CAPACITA' CAPACITÉ INHALT	PRESSIONE PRESSION DRUCK	DENTI/PESO TEETH/WEIGHT DENTS/POIDS ZÄHNE/GEWICHT			FORZA FORCE FORCE KRAFT	DIMENSIONI (mm) SIZES (mm) DIMENSIONS (mm) ABMESSUNGEN (mm)						MACCHINA MACHINE MACHINE MASCHINE
							LT	MAX-BAR	n°/KG			t	
MPV 550 FH	550	330	4/1020	5/1130	6/1240	3.0	1350	1940	2160	1740	1420	210	24-30
MPV 550 FH - OR 1 S	550	330	4/1180	5/1290	6/1400	3.0	1350	1940	2160	1740	1420	310	24-30
MPV 600 FH	600	330	4/1160	5/1320	6/1460	3.0	1470	1990	2230	1730	1450	210	25-40
MPV 600 FH - OR 1 S	600	330	4/1320	5/1480	6/1640	3.0	1470	1990	2230	1730	1450	310	25-40
MPV 700 FH	700	330	4/1260	5/1420	6/1580	2.8	1530	2130	2370	1800	1370	210	27-45
MPV 700 FH - OR 1 S	700	330	4/1420	5/1580	6/1740	2.8	1530	2130	2370	1800	1370	310	27-45
MPV 800 FH	800	330	4/1370	5/1530	6/1690	2.7	1600	2180	2430	1780	1500	210	28-45
MPV 800 FH - OR 1 S	800	330	4/1530	5/1690	6/1850	2.7	1600	2180	2430	1780	1500	310	28-45
MPV 1000 FH	1.000	330	4/1460	5/1640	6/1820	2.4	1690	2470	2730	1930	1540	210	30-45
MPV 1000 FH - OR 1 S	1.000	330	4/1620	5/1800	6/1980	2.4	1690	2470	2730	1930	1540	310	30-45



Call for advice on: 0844 770 7969 e-mail us: sales@approvedhydraulics.co.uk