

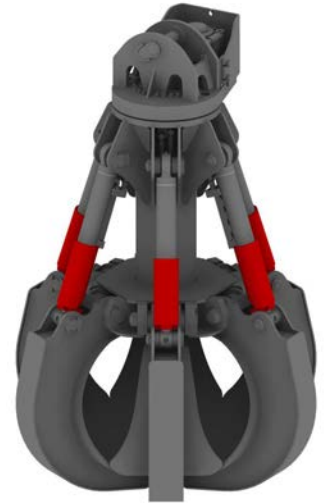

Hydraulic Equipment Industries

MPV - PH

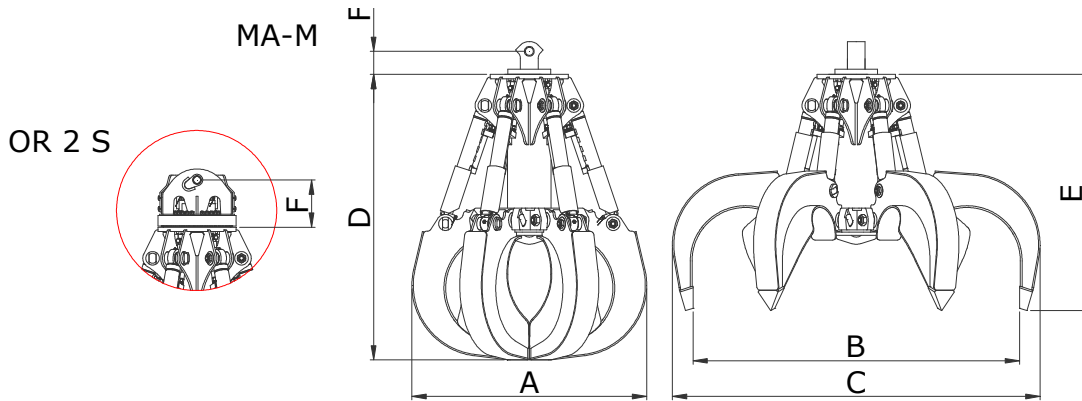

MODELLO MODEL MODÈLE MODELL	CAPACITA' CAPACITY CAPACITE INHALT	PRESSIONE PRESSURE PRESSION DRUCK	DENTI/PESO TEETH/WEIGHT DENTS/POIDS ZÄHNE/GEWICHT			FORZA FORCE FORCE KRAFT	DIMENSIONI (mm) SIZES (mm) DIMENSIONS (mm) ABMESSUNGEN (mm)						MACCHINA MACHINE MACHINE MASCHINE
							LT	MAX-BAR	n°/KG			t	
MPV 350 PH	350	330	4/750	5/810	6/910	2.3	1240	1740	1950	1570	1310	130	14-20
MPV 350 PH - OR 2 S	350	330	4/890	5/950	6/1050	2.3	1240	1740	1950	1570	1310	270	14-20
MPV 450 PH	450	330	4/780	5/890	6/960	2.1	1320	1840	2070	1610	1330	130	16-24
MPV 450 PH - OR 2 S	450	330	4/920	5/1030	6/1100	2.1	1320	1840	2070	1610	1330	270	16-24
MPV 550 PH	550	330	4/880	5/980	6/1070	2.0	1350	1940	2180	1660	1340	130	18-25
MPV 550 PH - OR 2 S	550	330	4/1020	5/1120	6/1210	2.0	1350	1940	2180	1660	1340	270	18-25



Call for advice on: 0844 770 7969 e-mail us: sales@approvedhydraulics.co.uk