

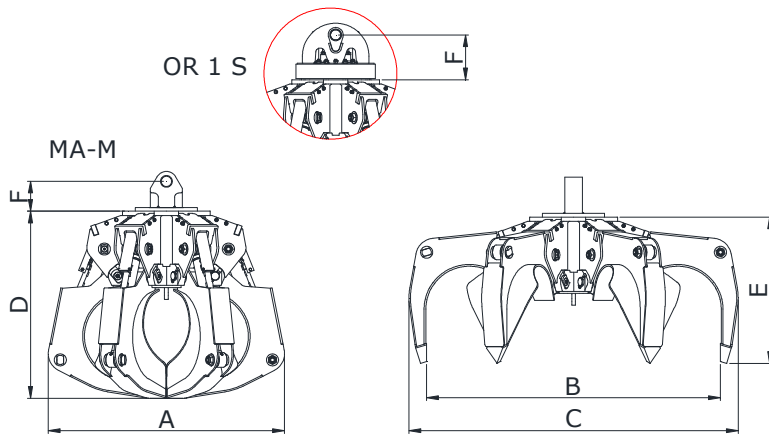

Hydraulic Equipment Industries

MPOS - FH



MODELLO MODEL MODÈLE MODELL	CAPACITÀ CAPACITY CAPACITÉ INHALT	PRESSIONE PRESSURE PRESSION DRUCK	DENTI/PESO TEETH/WEIGHT DENTS/POIDS ZÄHNE/GEWICHT			FORZA FORCE FORCE KRAFT	DIMENSIONI (mm) SIZES (mm) DIMENSIONS (mm) ABMESSUNGEN (mm)						MACCHINA MACHINE MACHINE
							LT	MAX-BAR	n°/KG			t	
MPOS 600 FH	600	330	4/1090	5/1240	6/1390	3.1	1600	1990	2230	1290	1010	210	24-40
MPOS 600 FH - OR 1 S	600	330	4/1250	5/1400	6/1550	3.1	1600	1990	2230	1290	1010	310	24-40
MPOS 700 FH	700	330	4/1170	5/1320	6/1470	2.9	1600	2130	2380	1360	1030	210	28-45
MPOS 700 FH - OR 1 S	700	330	4/1330	5/1480	6/1630	2.9	1600	2130	2380	1360	1030	310	28-45



Call for advice on: 0844 770 7969 e-mail us: sales@approvedhydraulics.co.uk