

Hydraulic Equipment Industries

MPOS - PZ

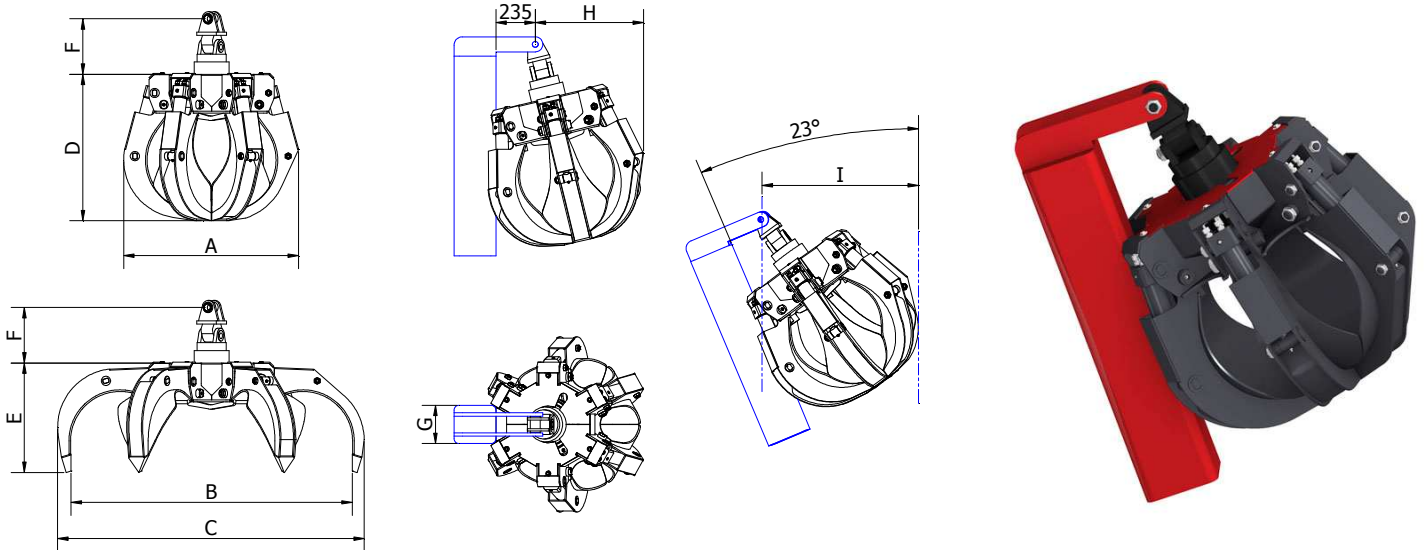

| MODELLO MODEL MODÈLE MODELL | CAPACITA' CAPACITY CAPACITÉ INHALT | PRESSIONE PRESSURE PRESSION DRUCK | DENTI/PESO TEETH/WEIGHT DENTS/POIDS ZÄHNE/GEWICHT | | | FORZA FORCE FORCE KRAFT | DIMENSIONI (mm) SIZES (mm) DIMENSIONS (mm) ABMESSUNGEN (mm) | | | | | | | | | MACCHINA MACHINE MACHINE MASCHINE |
|--------------------------------------|---|--|--|---|-------|----------------------------------|--|---------|-------|-----|-----|-----|-----|-----|-----|--|
| | | | | | | | LT | MAX-BAR | n°/KG | t | A | B | C | D | E | |
| MPOS 250 PZ | 250 | 300 | - | - | 6/390 | 1.2 | 1010 | 1560 | 1720 | 820 | 650 | 330 | 230 | 640 | 890 | 7-12 |
| MPOS 250 PZ RI | 250 | 300 | - | - | 6/435 | 1.2 | 1010 | 1560 | 1720 | 820 | 650 | 330 | 230 | 640 | 890 | 7-12 |
| MPOS 300 PZ | 300 | 300 | - | - | 6/420 | 1.1 | 1040 | 1680 | 1830 | 890 | 670 | 330 | 230 | 650 | 935 | 7-12 |
| MPOS 300 PZ RI | 300 | 300 | - | - | 6/465 | 1.1 | 1040 | 1680 | 1830 | 890 | 670 | 330 | 230 | 650 | 935 | 7-12 |



Call for advice on: 0844 770 7969 e-mail us: sales@approvedhydraulics.co.uk