

# INSTALLATION INSTRUCTIONS FOR VISION LITE KITS

## Installation Instructions for Models VLF-EZ, VSL (Slimline), VSIG, VLFEZIG, Frames

### UL10B or UL10C Positive Pressure:

1. Read and follow the installation requirements of the door manufacturers.
2. Cut the hole in the door to correspond to the order size of the vision frame. Assure that the opening is plumb and square.
3. Prepare the cutout if required, per the door manufacturers installation instructions.
4. Carefully inspect the glass edges. Superficial chips smaller than 5/32" (4mm) are acceptable, however, deeper chips (with V profile) are not acceptable and should not be installed.
5. Install caulking, tape or compound to both sides of the frame or both sides of glass using listed and approved material appropriate for the fire rating desired.
6. **For UL10C installations only**, in 20 minute wood doors, apply additional intumescent tape to the underside of the metal retainer.
7. Insert the corridor side frame in the cutout, squaring to door.
8. Insert glass into frame, seating firmly, using setting blocks as needed. Install so that the appropriate (WHI) or (UL) markings on the glass remain permanently visible.
9. Inserting 2 of the screws provided in the countersunk holes, carefully align the room side of the frame to the holes in the corridor side of the frame. Screw in enough to hold frame in place for alignment, then insert the other screws lightly. Tighten the screws alternately in a criss-cross pattern to avoid putting more pressure on one side than the other. Do not tighten to the point of deflecting the frame.

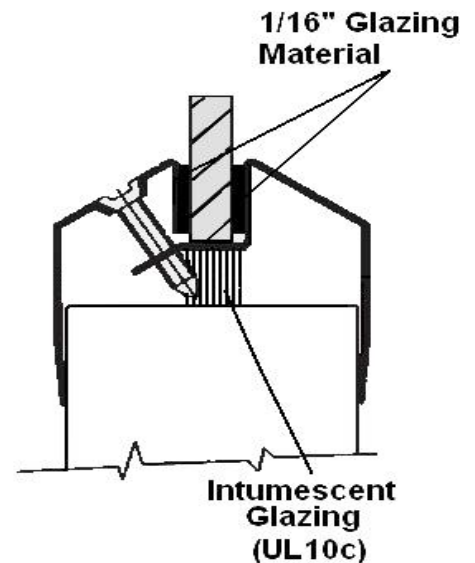

## Installation Instructions for VLF, VLFIG, VLF-Shapes, VLF-SG Frames

### UL10B or UL10C Positive Pressure:

1. Read and follow the installation requirements of the door manufacturers.
2. Cut the hole in the door to correspond to the order size of the vision frame. Assure that the opening is plumb and square.
3. Prepare the cutout if required, per the door manufacturers installation instructions.
4. Carefully inspect the glass edges. Superficial chips smaller than 5/32" (4mm) are acceptable, however, deeper chips (with V profile) are not acceptable and should not be installed.
5. Using the vision frame mounting holes as a template, drill holes in the door for the thru-bolts.
6. Install caulking, tape or compound to both sides of the frame or both sides of glass using listed and approved material appropriate for the fire rating desired.
7. **For UL10C installations Only**, in 20 minute wood doors, apply additional intumescent tape in cutout around perimeter of glass.
8. Insert the corridor side frame in the cutout, aligning frame to the bottom of the cutout.
9. Insert glass into frame, seating firmly, using setting blocks as needed. Install so that the appropriate (WHI) or (UL) markings on the glass remain permanently visible.
10. Inserting 2 of the screws provided in the countersunk holes, carefully align the room side of the frame to the holes in the corridor side of the frame. Screw in enough to hold frame in place for alignment, then insert the other screws lightly. Tighten the screws alternately in a criss-cross pattern to avoid putting more pressure on one side than the other. Do not tighten to the point of deflecting the frame.

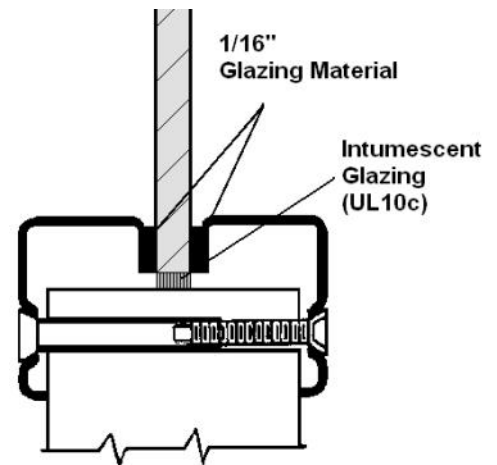

**INSTALLATION INSTRUCTIONS FOR  
VISION LITE KITS**  
**Install only glass with the same rating as the vision  
frame & door in fire or impact-rated door assemblies.**

ACPG WEST COAST & MANUFACTURING: COMMERCE, CA HEADQUARTERS & MANUFACTURING: BLOOMINGTON, MN  
PH: 800-554-6077 FAX: 952-835-2218 EMAIL: SALES@ACTIVARCPG.COM WWW.ACTIVARCPG.COM •

ACPG WAREHOUSES: LANCASTER PA, ATLANTA GA, CHICAGO IL, SEATTLE WA, DALLAS TX, FORT MYERS FL, FARGO ND, OMAHA NE

8/26/2014