



640072

Electro-Mechanical Swing Operator

FALCON[®]

Models 8230 & 8240

Installation Instructions

Table of Contents

General.....	1
Replacement Parts & System Components	1
1 Pre-Installation Site & Product Check.....	2
2 Operator Installation	3
3 Wiring.....	5
4 Arm & Cover Installation	5
5 Operational Check.....	7
6 Operator Adjustment.....	8
7 Release For Service	10
8 Falcon Software.....	10

General

The Falcon Operator is a low energy automatic electromechanical swinging door operator for use on hinged, center pivoted and offset pivoted doors. When activated, the Falcon drives the door to full open position, then electrical power is turned off and the door is closed by spring force. The activating circuit opens the door from any position in the closing swing. During a power failure, the Falcon Operator acts as a manual door closer (Size 3). Door opening and closing cycles, including opening speed, back check speed, hold open time delay, closing speed, latch position, and backcheck position are adjustable.



WARNING

Always disconnect main power to the operator prior to servicing or cleaning.



CAUTION

This operator is for indoor use only.



CAUTION

Do not mount any accessories directly to the operator.

Replacement Parts & System Components

Part	26" Header
Control Box	8230-3462 8240-3462
Gear Box	8230-3454 8240-3462

Part	Pull	Standard Push	Finish
Arm Assembly	8230-3077T	8240-3077	AL689

26" Pull System (screw pack not shown)

Swing door operator

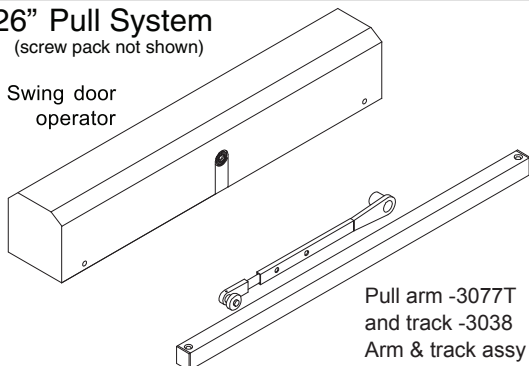

Pull arm -3077T
and track -3038
Arm & track assy -3077PLCM

26" Push System (screw pack not shown)

Swing door operator

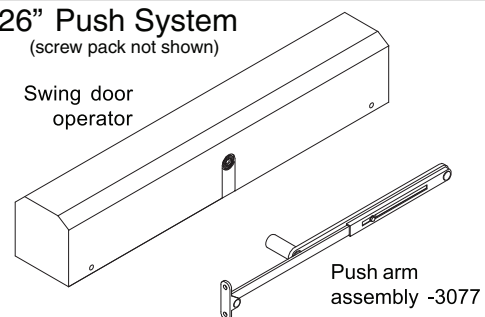

Push arm assembly -3077

1 Pre-Installation Site & Product Check

- 1a Check that the product model is correct for the required application.
- 1b Check that all parts listed on the Bill of Material are in the shipping container.
- 1c Check the architectural drawings and final approved shop drawings for the position of frame and structural openings.
- 1d Check header and frame dimensions and required clearances.

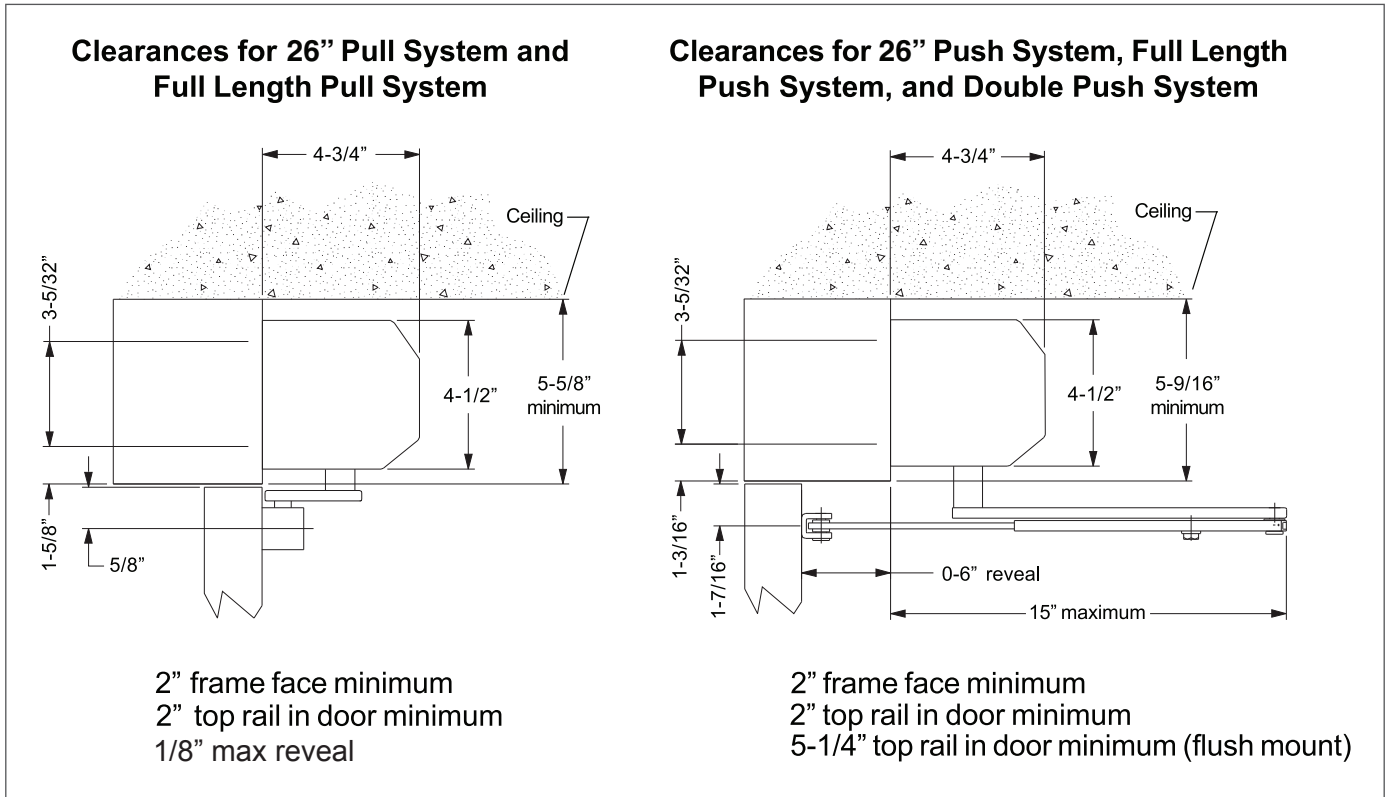

- 1e Check door width:
26" minimum for 26" Push Operator
30" minimum for 26" Pull Operator
- 1f Check that door weight is 200 lbs. or less. For heavier door, consult factory.
- 1g Check that a 115 volt, single phase, 60 Hz, fused 15 amp, 3-wire power supply is available at the side jamb with approximately 12" of wire available to connect to the Operator. UL approved flexible conduit is recommended for the 115 volt power line.
The 115 volt power supply must be a dedicated circuit from the main circuit breaker panel and must NOT be connected into any building lighting system that operates florescent lights.

2 Operator Installation

2a Remove Control Box from Operator Mounting Bracket, then remove Motor/Gearbox from Bracket:

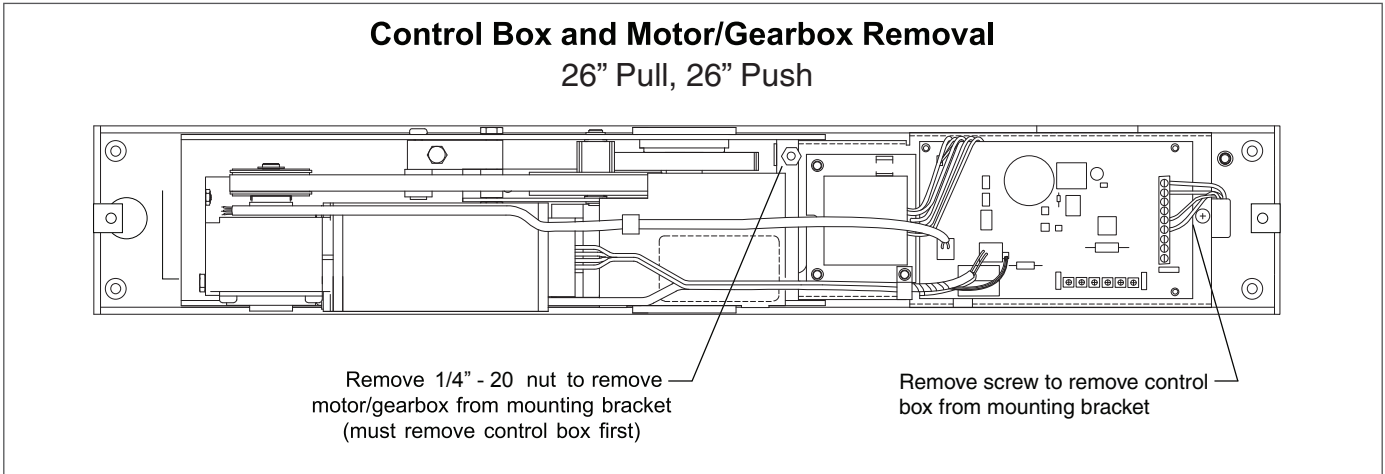

2b Prepare Header/Frame and Door:
26" Pull System..... See Below
26" Push System Page 5
Drop Mount Application..... Page 5

2c Install Operator Mounting Bracket on Header/Frame. Do not install the center screws until you've attached the Motor Gearbox assembly in step 2d.

2d Install Motor/Gearbox on Operator Mounting Bracket. If there is not a mounting surface for both screws on the Gearbox, use the 1/4"-20 nut removed in 2.1 to secure the gearbox. Then install the Control Box.

2e Proceed to Step 3: Wiring (page 6).

⚠ CAUTION ⚠

When mounting to an aluminum frame, the use of rivet nuts is strongly recommended.

26" Pull System Header/Frame and Door Preparation

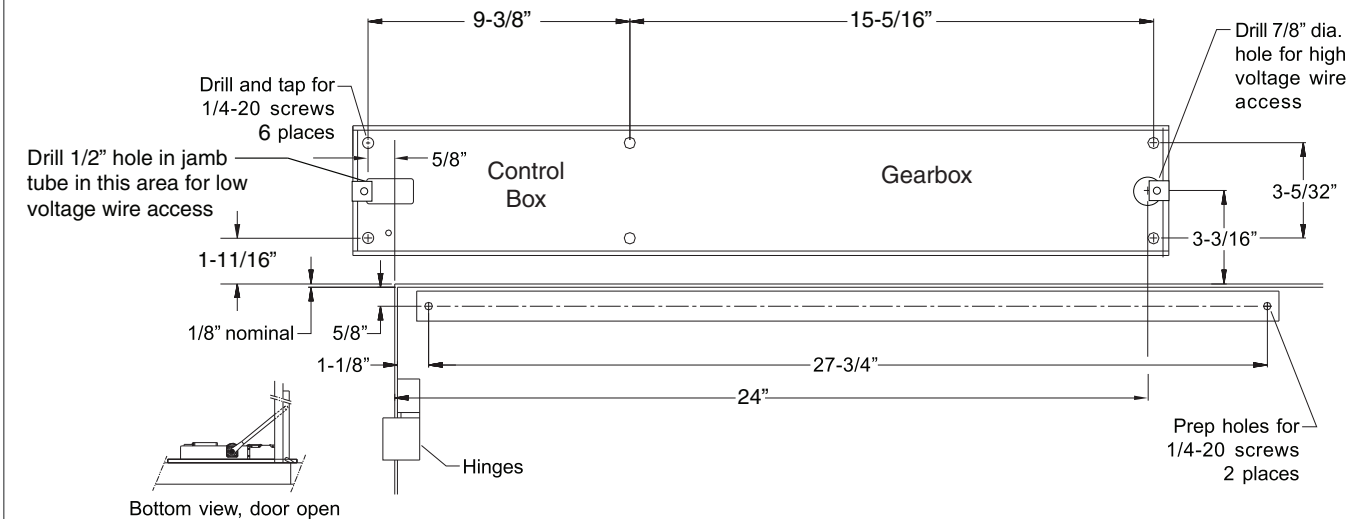

3 Wiring

⚠ CAUTION ⚠

Make sure all wires are properly dressed and secured to prevent interference
Route all wiring away from moving parts, sharp edges, and heat sources
Use copper conductors only
Do not modify the factory wiring or connect into existing electrical circuits or devices

3a Refer to the appropriate wiring diagram for the Control Box (page 12) or the diagram supplied for custom applications. Connect the following cables:

- Ground Cable (Ground the Operator properly with the earth from main supply)
- Hall Effect Cable (Do not wrap the Hall Effect Cable around the Motor Power Cable)
- Motor Power Cable (Do not wrap the Motor Power Cable around the Hall Effect Cable)
- Control Box Power Cable

3b Connect activate and lock accessories, as needed. Refer to the accessory instructions for any accessories used. Do not connect any remote activating device to the door unless it is located within line of sight of the door.

3c When wiring is complete, proceed to Step 4: Arm and Cover Installation (page 6).

4 Arm & Cover Installation

⚠ WARNING ⚠

Keep hands, clothing, wires, tools, etc., AWAY FROM Operator Motor when the Operator Motor is turned on.

4a Make sure the Operator Power is connected.

4b Install a jumper across the control box Main Act and Main Act Com.

4c The operator motor will activate and drive to the Full Open position, and remain there.

4d Push Arm Installation

1. Open the door to 90°, and attach the Main Arm to the operator spindle at 90° to the opening (+/- 10°) with the 8mm socket head screw (see fig. 1).
2. Remove the arm locking screw from the Rod & Shoe. Insert rod into forearm tube and reinstall the arm locking screw loosely. Attach Rod & Shoe to door. With the door open to 90°, tighten the arm locking screw (see fig. 2).

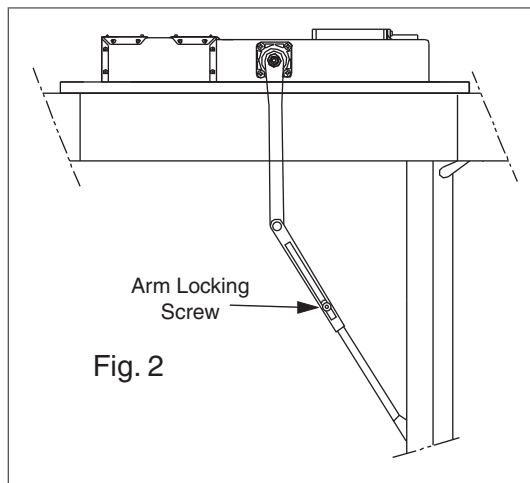
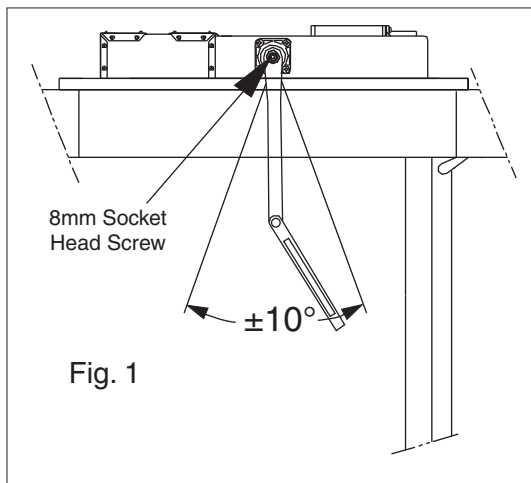

4e Pull Arm Installation

1. Slide the pull arm roller into the track, then insert a track end cap on each end of the track and install track to door.
2. Attach the Pull Arm to the track roller with the roller locking screw and to the operator spindle loosely with the 8mm socket head screw. Open the door to 90°, and tighten the 8mm socket head screw (see fig. 3).
3. Attach arm if required. Due to the mesh of the arm to operator spindle, the door may be open to slightly more or less than 90°. To adjust arm, remove arm adjustment screws, push door open to 90° and reinstall arm screws (see fig. 4).

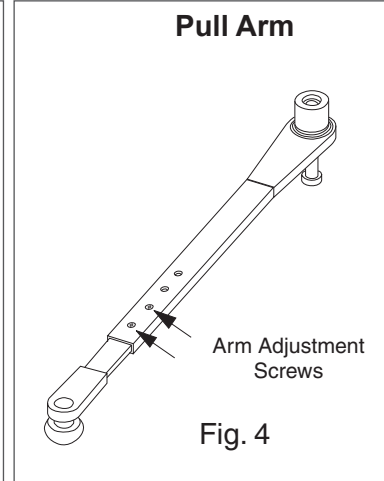
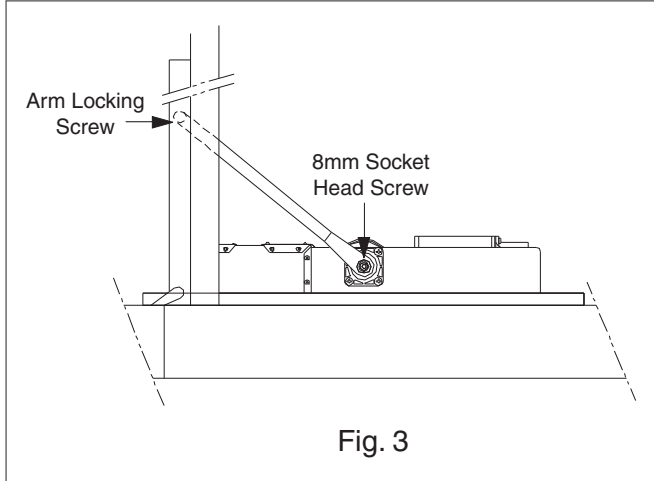

4f Remove the jumper from the control box Main Act and Main Act Com. The door should close.

4g Connect actuator wiring as required (see page 12).

4h Test the operator. (See Chapter 5: Operational Check on page 8)

4i Adjust the operator as required. (See Step 6: Operator Adjustment on page 9)

4j Install the cover assembly onto the operator.

4k Release the operator for service. (See Step 7: Release for Service on page 11)

5 Operational Check

5a Activate the operator using the activation device. The operator will perform one sizing cycle.
Sizing Cycle: Occurs after power is turned on and a legitimate activation signal is received. During the sizing cycle, the door opens and closes one time.

5b If the door does NOT OPEN AT ALL during the sizing cycle:

- Check the door for binding.
- If an electromechanical lock is being used, check that the lock disengages before the operator opens the door.
- Check fuses, circuit breakers and connections.
- Adjust the operator and check the door operation (see Step 6: Operator Adjustment on page 9).

Below are default settings:

Opening Speed	9:00
Back Check Speed	3:00
Hold Open Time Delay	10:00
Latch Position	12:00
Closing Speed	12:00
Back Check Position	4:00 (fully clockwise)

5c If the door does NOT OPEN FULLY during the sizing cycle:

- Check the door for binding.
- Increase the back check speed slightly and re-check the door operation. Repeat until door opens fully.

5d If the door OPENS TOO FAST during the sizing cycle, decrease the back check speed slightly and re-check the door operation. Repeat until the door opens at desired speed.

5e After the sizing cycle is completed and the door(s) are closed, apply a maintained activation signal. Check that the door remains open while the signal is applied.

5f When the door is operating properly, continue with step 4k on page 7.

6 Operator Adjustment

See table below and diagrams (page 10) for operator feature adjustment.

After adjusting, cycle the door several times to check for proper operation.

NOTE

Adjust Operator for the SLOWEST operation practical, in accordance with the latest revisions of the Americans with Disabilities Act (ADA); ANSI/BHMA A156.19 Standards for Power-Assisted and Low Energy Power-Operated Doors; and local codes.

Opening Speed: 5 seconds or more

Latch Location: 10 degrees or more

Closing Speed: 3 seconds or more

Latch Speed: 1.5 seconds or more

Features	Control	Description	Counter Clockwise	Clockwise
Opening Speed	Opening Speed	Controls opening speed of door	Slower	Faster
Back Check Speed	Back Check Speed	Controls the speed of the door near the full open position to prevent door slamming	Slower	Faster
Hold Open Time Delay	Hold Open Time Delay	Controls the length of time the door remains in the full open position: 1 sec to 30 sec	Less Time Down to 1 sec	More Time Up to 30 sec
Back Check Position	Back Check Position	Door position where back check speed engages	Less Pressure Required	More Pressure Required
Latch Position	Latch Position	Door position at which deceleration towards full closed begins in order to prevent door slamming	Less Latch	More Latch
Closing Speed	Closing Speed	Controls closing speed of door	Slower	Faster
Delayed Activation	DLY	ON: Delays opening of door for strike applications (1 second delay)		
Push and Go	PNG	ON: Pushing the door open 5° causes operator to open door for remainder of open cycle		

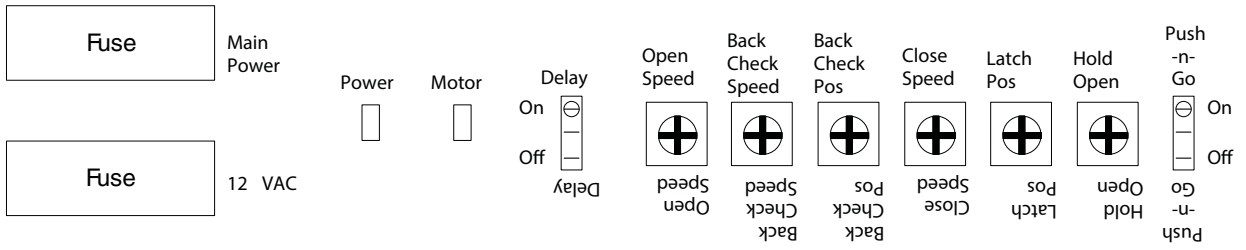
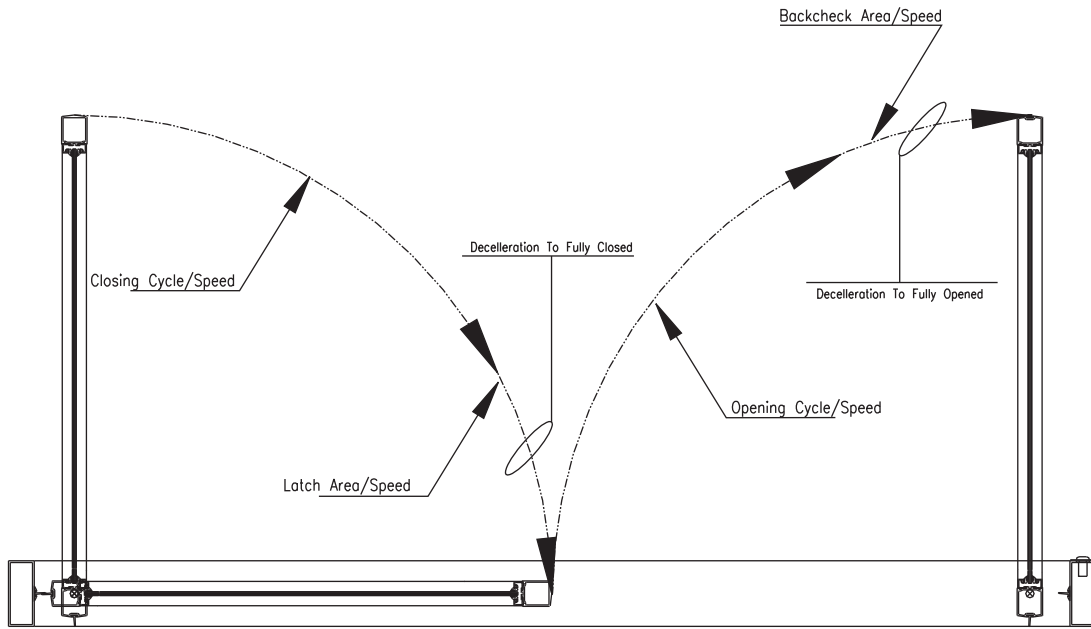

7 Release For Service

7a Remove all tools, installation equipment and debris from the vicinity of the door.

7b **MANDATORY:** Install all Safety, Traffic Control and Instruction Labels onto the door, as required. Failure to do this will leave the **INSTALLER LIABLE** for any accidents that occur.

7c Give verbal instruction on how to properly operate the door to the owner or person in charge.

7d Give verbal instruction to the owner or person in charge on periodic inspection of the door for the following:

- Occasional damage
- Developing problems
- Minor preventative maintenance

7e Provide the owner or person in charge with a contact name and phone number to call for future service and maintenance.

IMPORTANT

Be sure to install all Safety, Traffic Control and Instruction Labels onto the door, as required.

8 Falcon Software

8a Operation:

1. Sizing:

From start-up (sizing), the door will activate via:

Main Input (Main Act and Main Act Com).

The first motion of the door will be towards the Door Open position. The speed during Sizing is automatic and cannot be set from a potentiometer.

The door drives to full open and the system sets the open counter to full open.

The door closes at Closing Speed. The system sets the closed counter to Full Closed when the latch goes up at the Closed position.

The system calculates all other parameters required for normal operation based on the two values of Full Open and Full Closed.

2. Standard Operation

Upon a legitimate activation signal, the door accelerates to opening speed while monitoring the current load on the drive output. If the current exceeds the specified level, the door will stop and close.

The door travels at its set speed (based on the potentiometer setting) until it reaches the Back Check position, where it will decelerate to the Back Check Speed.

The door will stop at the Hold Open position and remain there until an activation or the Hold Open Timer is cleared.

The door then closes at its Closing Speed (based on the potentiometer setting) up to the latched position.

If the Closing Speed is decreased by driving the motor in the open direction (a fixed setting), power is added to allow the spring to continue closing the door to the Full Closed position.

8b Wiring

