

3300A SERIES HOLDERS & STOPS

SURFACE MOUNT, ADJUSTABLE

- 3310A HOLD-OPEN
- 3320A STOP
- 3330A FRICTION

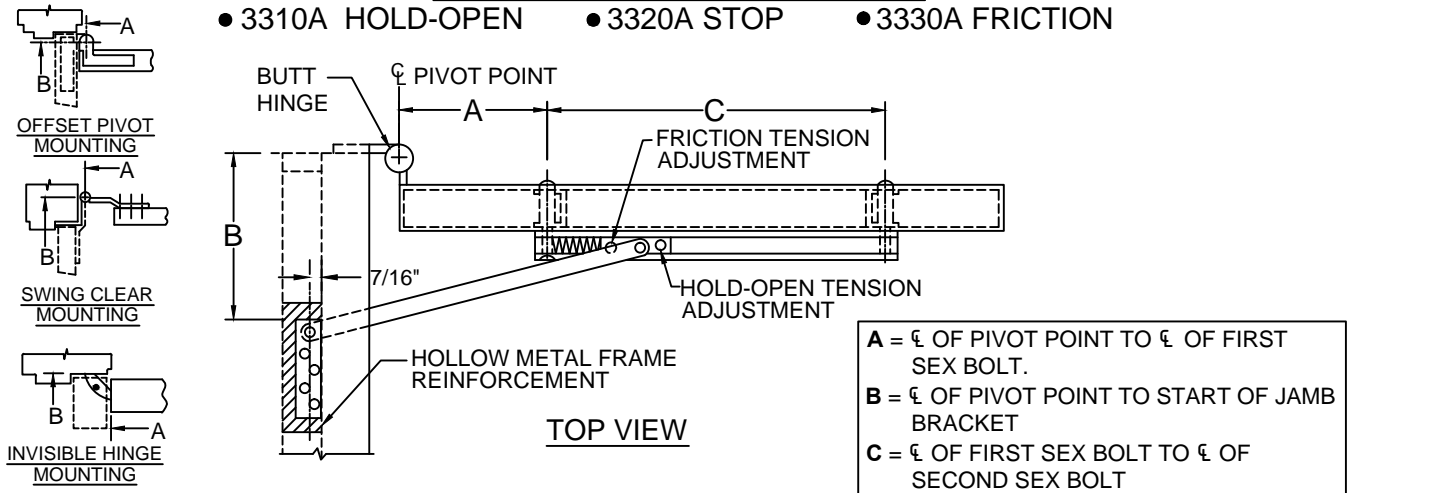

A = ϕ OF PIVOT POINT TO ϕ OF FIRST SEX BOLT.
B = ϕ OF PIVOT POINT TO START OF JAMB BRACKET
C = ϕ OF FIRST SEX BOLT TO ϕ OF SECOND SEX BOLT

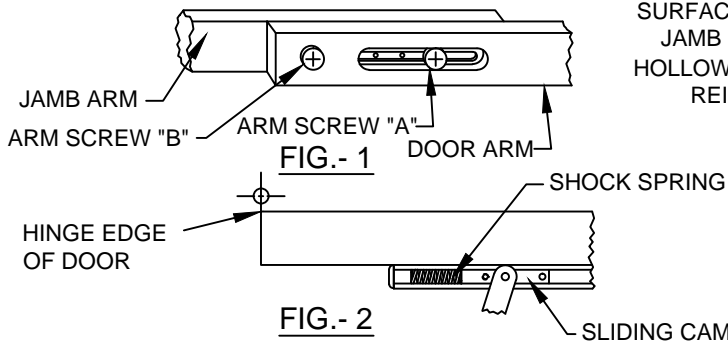
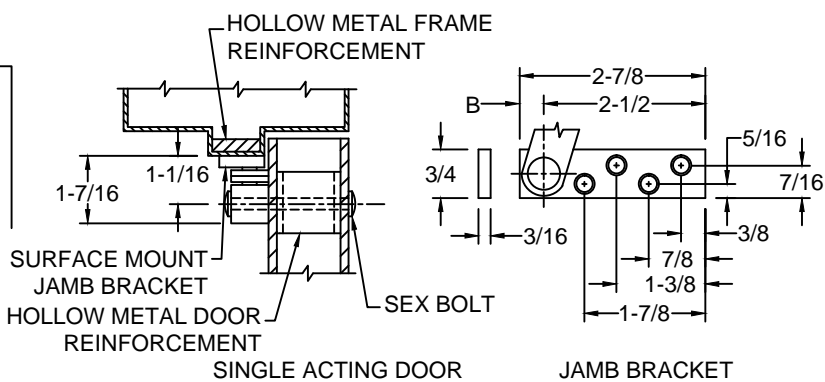
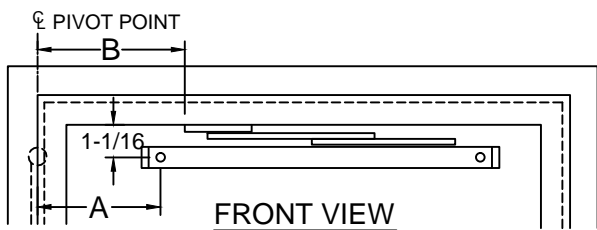

TO CHANGE HOLD OPEN OR STOP DEGREE

- LOOSEN "ARM SCREW A" IN SLOTTED SECTION. SEE FIG.-1. DO NOT REMOVE.
- REMOVE "ARM SCREW B" ONLY. SEE FIG.-1.
- OPEN DOOR TO DESIRED DEGREE.
- POSITION "SLIDING CAM" AGAINST "SHOCK SPRING" SEE FIG.-2.
- INSTALL "ARM SCREW B" IN ARM AND SECURE.
- TIGHTEN "ARM SCREW A" SECURELY.

CAUTION:

ARM SCREW "B" MUST BE INSTALLED & BOTH SCREWS "A" AND "B" SECURED OR UNIT WILL FAIL TO HOLD POSITION

NOTES:

1. REVERSIBLE/ NON - HANDED
2. FOR SINGLE ACTING DOORS ONLY
3. ALL DRILLING & TAPPING TO BE DONE IN FIELD.
4. ALWAYS REQUEST LATEST TEMPLATE/ DRAWING FOR NEW INSTALLATIONS.
5. ALL DIMENSIONS ARE IN INCHES.
6. DRAWING IS NOT TO SCALE

DOOR THICKNESS	MODEL NO.	DOOR OPENING	SET FOR 95° H.O.		
			A	B	C
1-3/4" TO 2-1/4"	● 3311A	24 TO 29-15/16	5	6-3/8	15-13/16
	● 3321A				
	● 3331A				
HINGES & OFFSET PIVOTS	● 3312A	30 TO 35-15/16	9	7-7/8	17-11/16
	● 3322A				
	● 3332A				
HINGES & OFFSET PIVOTS	● 3313A	36 TO 42	13-1/16	9-5/16	19-7/16
	● 3323A				
	● 3333A				

SCREW DETAIL			
	QTY	WOOD	METAL
JAMB	4	#10 x 1-1/2" FLAT HEAD, UNDER CUT WOOD SCREW	#10-32 x 1/2" FLAT HEAD MACHINE SCREW
DOOR	2	#10-32 x 1-1/2" TRUSS HEAD & 5/16" DIA. SEX BOLT	#10-32 x 1-1/2" TRUSS HEAD & 5/16" DIA. SEX BOLT



www.abhmfg.com
 E-mail: abhinfo@abhmfg.com
 Architectural Builders Hardware Mfg., Inc.
 1222 Ardmore Ave., Itasca, IL 60143
 630.875.9900; FAX 800.9FAXABH (932.9224)

©2016 ABH Mfg., Inc.
 printed in USA

3300A-00.DWG

3300A

1 OF 1
 REVISED 05-17-16