

1000 SERIES CONCEALED HOLDERS & STOPS

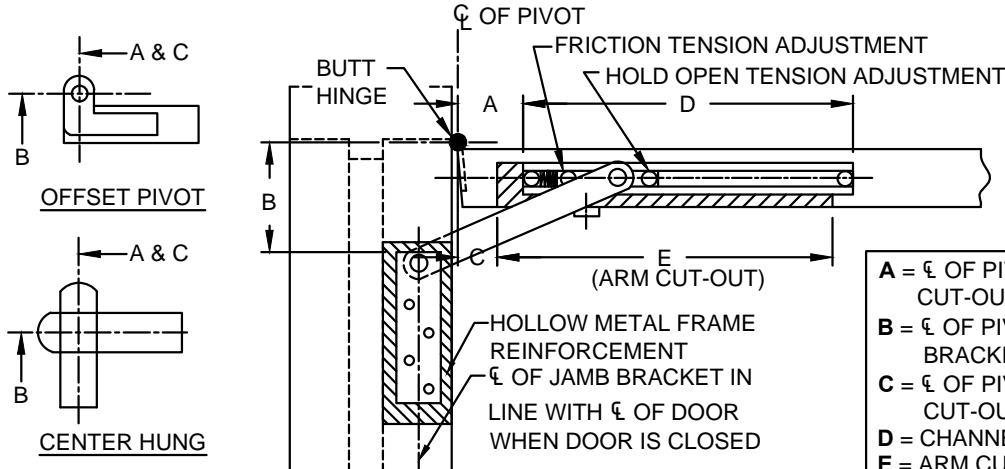

A = ϕ OF PIVOT POINT TO START OF CHANNEL CUT-OUT
B = ϕ OF PIVOT POINT TO START OF JAMB BRACKET
C = ϕ OF PIVOT POINT TO START OF ARM CUT-OUT
D = CHANNEL CUT-OUT LENGTH
E = ARM CUT-OUT

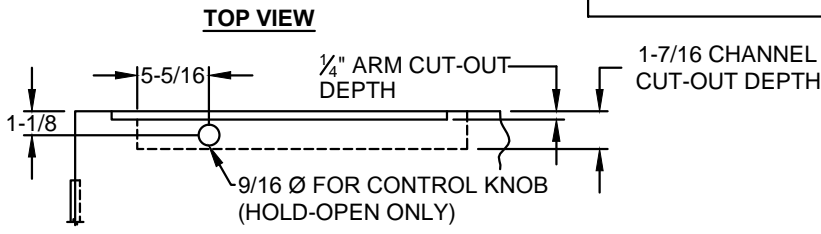

- NOTES:**
1. REVERSIBLE/ NON - HANDED
 2. FOR SINGLE OR DOUBLE ACTING DOORS
 3. ALWAYS REQUEST LATEST TEMPLATE/ DRAWING FOR NEW INSTALLATIONS.
 4. ALL DIMENSIONS ARE IN INCHES.
 5. DRAWING IS NOT TO SCALE.
 6. ALL DRILLING AND TAPPING TO BE DONE IN FIELD.

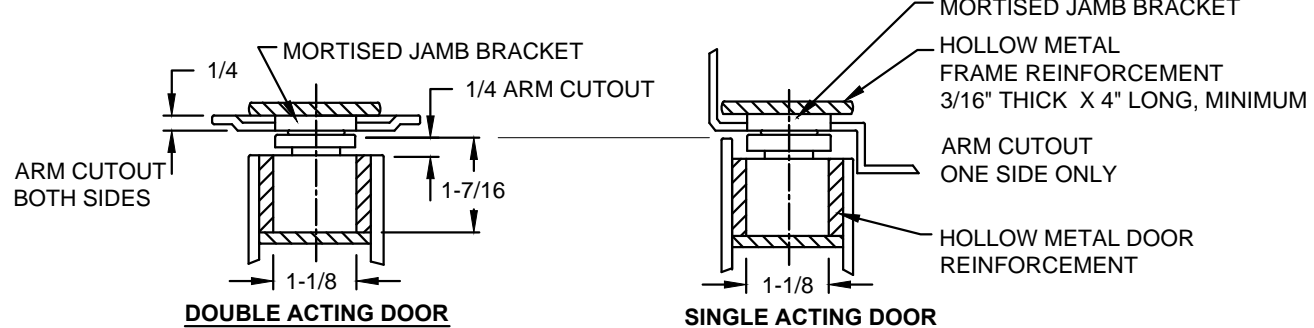
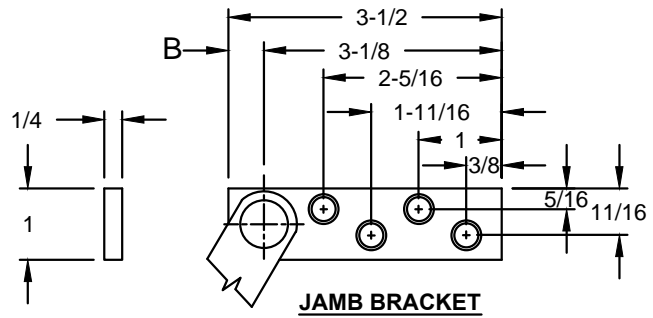

SCREW DETAIL			
	QTY	WOOD	METAL
JAMB	4	#14 X 1-1/2" FLAT HEAD WOOD SCREW	1/4"- 20 x 3/4" FLAT HEAD MACHINE SCREW
DOOR	2	#18 X 2-1/2" FLAT HEAD WOOD SCREW	5/16" -18 x 1-1/2" FLAT HEAD MACHINE SCREW



www.abhmfg.com
 E-mail: abhinfo@abhmfg.com
 Architectural Builders Hardware Mfg., Inc.
 1222 Ardmore Ave., Itasca, IL 60143
 630.875.9900; FAX 800.9FAXABH (932.9224)

©2017 ABH Mfg., Inc. printed in USA

1000

PAGE 1 OF 2
REVISED 05-02-17

1000-1-10.DWG

1000 SERIES CONCEALED HOLDERS & STOPS

● 1010 HOLD-OPEN ● 1020 STOP ● 1030 FRICTION

FOR DEAD STOP ADD 5/8" TO "A" DIMENSION
* BUTT HINGE ONLY

BUTT HINGE/ SWING CLEAR & OFFSET PIVOT, DOOR THICKNESS = 1-3/4" TO 2-1/4"

DEGREE		85° H.O.				90° H.O.				95° H.O.				
MODEL NO.	DOOR OPENING	A	B	C	E	A	B	C	E	A	B	C	E	D
●1016 ●1026 ●1036	18 to 22-15/16	1-1/2 *	4-1/8 *	1-1/2 *	13-1/4 *	1-3/8 *	3-3/8 *	0 *	13-7/8 *	1-3/8 *	2-9/16 *	0 *	13-1/4 *	15-9/16
●1017 ●1027 ●1037	23 to 26-15/16	4-5/16	4-15/16	4-5/16	14	4-1/16	4-5/16	3	14-7/8	3-3/4 *	4-1/4 *	2-1/8 *	15-3/4 *	16-7/8
●1011 ●1021 ●1031	27 to 29-15/16	6-1/8	6-1/8	5-1/2	16-7/8	5-11/16	5-11/16	5	16-7/8	5-3/8	5-3/8	4-1/2	17-1/8	18-5/8
●1012 ●1022 ●1032	30 to 35-15/16	7-3/8	7-3/8	6-3/4	18-5/16	6-15/16	6-15/16	6-1/4	18-3/8	6-1/2	6-1/2	5-3/4	18-7/16	20-1/16
●1013 ●1023 ●1033	36 to 39-15/16	11-5/8	8-9/16	6-3/4	22-7/8	11-1/16	8	7-1/4	22-7/8	10-5/8	7-9/16	6-3/4	22-7/8	21-3/8
●1014 ●1024 ●1034	40 to 43-15/16	14-7/16	9-5/8	9	25-5/8	13-7/8	9-1/16	8-1/4	25-7/8	13-5/16	8-1/2	7-3/4	25-3/4	22-9/16
●1015 ●1025 ●1035	44 to 52	17-5/16	10-11/16	10	28-5/8	16-5/8	10	9-1/4	28-5/8	16-1/16	9-7/16	8-3/4	28-5/8	23-11/16

DEGREE		100° H.O.				105° H.O.				110° H.O.				
MODEL NO.	DOOR OPENING	A	B	C	E	A	B	C	E	A	B	C	E	D
●1016 ●1026 ●1036	18 to 22-15/16	1-1/4 *	1-15/16 *	0 *	12-5/8 *	—	—	—	—	—	—	—	—	15-9/16
●1017 ●1027 ●1037	23 to 26-15/16	3-1/2 *	4-11/16 *	1/2 *	17 *	3-1/4 *	3-15/16 *	0 *	17-3/8 *	3 *	3-7/8 *	0 *	17-3/8 *	16-7/8
●1011 ●1021 ●1031	27 to 29-15/16	5-1/16 *	4-11/16 *	2 *	19-5/16 *	—	—	—	—	—	—	—	—	18-5/8
●1012 ●1022 ●1032	30 to 35-15/16	6-3/16	6-3/16	5-1/2	18-3/8	5-7/8	5-7/8	3-13/16	19-3/4	5-5/8 *	5-5/8 *	1 *	22-5/16 *	20-1/16
●1013 ●1023 ●1033	36 to 39-15/16	10-3/16	7-1/8	6-1/2	22-3/4	9-13/16	6-3/4	6	22-3/4	9-1/2	6-7/16	5	23-1/2	21-3/8
●1014 ●1024 ●1034	40 to 43-15/16	12-13/16	8	7-1/4	25-3/4	12-7/16	7-5/8	7	25-5/8	12-1/16	7-1/4	6-1/2	25-3/4	22-9/16
●1015 ●1025 ●1035	44 to 52	15-1/2	8-7/8	8	28-13/16	15-1/16	8-7/16	7-3/4	28-5/8	14-11/16	8-1/16	7-1/4	28-3/4	23-11/16

CENTER HUNG , DOOR THICKNESS = 1-3/4" TO 2-1/4"

DEGREE		85° H.O.				90° H.O.				95° H.O.				
MODEL NO.	DOOR OPENING	A	B	C	E	A	B	C	E	A	B	C	E	D
●1016 ●1026 ●1036	24 to 26-15/16	—	—	—	—	—	—	—	—	—	—	—	—	15-9/16
●1017 ●1027 ●1037	27 to 29-15/16	—	—	—	—	—	—	—	—	—	—	—	—	16-7/8
●1011 ●1021 ●1031	30 to 32-15/16	6-7/8	6-7/8	6-1/4	16-7/8	6-7/16	6-7/16	5-3/4	16-7/8	6-1/8	6-1/8	5-3/8	16-7/8	18-5/8
●1012 ●1022 ●1032	33 to 38-15/16	8	8	7-1/4	18-7/16	7-1/2	7-1/2	6-3/4	18-7/16	7-1/8	7-1/8	6-1/2	18-5/16	20-1/16
●1013 ●1023 ●1033	39 to 42-15/16	12-5/16	9-1/4	8-1/2	22-7/8	11-3/4	8-11/16	8	22-3/4	11-1/4	8-3/16	7-1/2	22-3/4	21-3/8
●1014 ●1024 ●1034	43 to 46-15/16	15-1/4	10-7/16	9-3/4	25-3/4	14-9/16	9-3/4	9	25-3/4	14	9-3/16	8-1/2	25-3/4	22-9/16
●1015 ●1025 ●1035	47 to 54	18-1/8	11-1/2	10-3/4	28-3/4	17-3/8	10-3/4	10	28-3/4	16-3/4	10-1/8	9-1/2	28-5/8	23-11/16

DEGREE		100° H.O.				105° H.O.				110° H.O.				
MODEL NO.	DOOR OPENING	A	B	C	E	A	B	C	E	A	B	C	E	D
●1016 ●1026 ●1036	24 to 26-15/16	—	—	—	—	—	—	—	—	—	—	—	—	15-9/16
●1017 ●1027 ●1037	27 to 29-15/16	—	—	—	—	—	—	—	—	—	—	—	—	16-7/8
●1011 ●1021 ●1031	30 to 32-15/16	—	—	—	—	—	—	—	—	—	—	—	—	18-5/8
●1012 ●1022 ●1032	33 to 38-15/16	6-11/16	6-11/16	6	18-3/8	6-3/8	6-3/8	5-3/4	18-5/16	6-1/8	6-1/8	5-1/2	18-5/16	20-1/16
●1013 ●1023 ●1033	39 to 42-15/16	10-13/16	7-3/4	7-1/8	22-3/4	10-7/16	7-3/8	6-3/4	22-3/4	10-1/8	7-1/16	6-3/8	22-3/4	21-3/8
●1014 ●1024 ●1034	43 to 46-15/16	13-9/16	8-3/4	8	25-3/4	13-1/8	8-5/16	7-1/2	25-3/4	12-3/4	7-9/16	7-1/4	25-3/4	22-9/16
●1015 ●1025 ●1035	47 to 54	16-1/4	9-5/8	9	28-5/8	15-3/4	9-1/8	8-1/2	28-5/8	15-5/16	8-11/16	8	28-5/8	23-11/16



www.abhmfg.com
E-mail: abhinfo@abhmfg.com
Architectural Builders Hardware Mfg., Inc.
1222 Ardmore Ave., Itasca, IL 60143
630.875.9900; FAX 800.9FAXABH (932.9224)

©2017 ABH Mfg., Inc.
printed in USA

1000

PAGE 2 OF 2
REVISED 05-02-17