

1000SL SERIES SLIM-LINE CONCEALED HOLDERS & STOPS

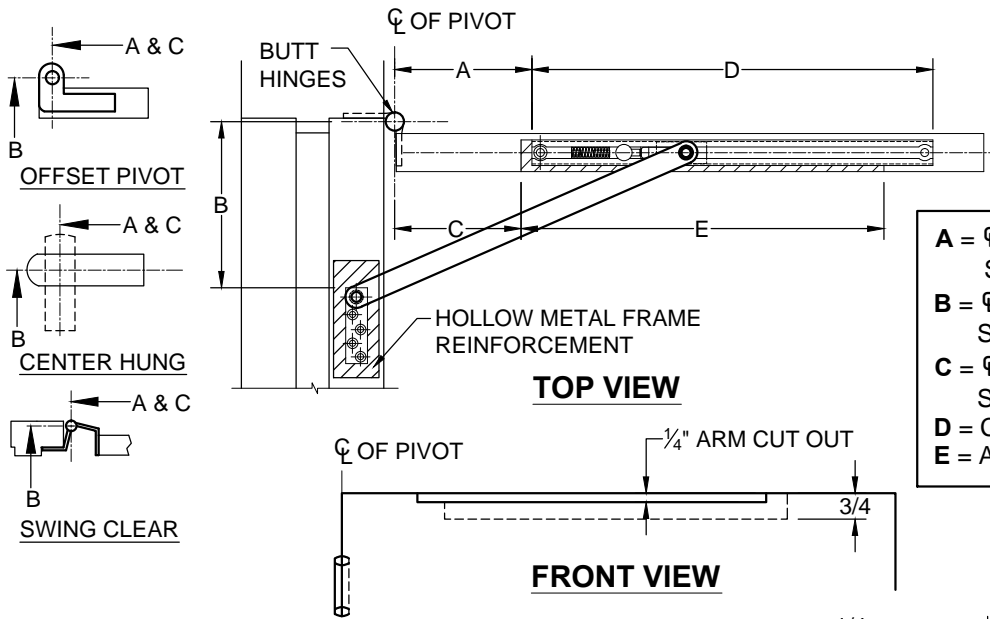

A = CL OF PIVOT POINT TO START OF CHANNEL CUT-OUT
B = CL OF PIVOT POINT TO START JAMB BRACKET
C = CL OF PIVOT POINT TO START OF ARM CUT OUT
D = CHANNEL CUT-OUT LENGTH
E = ARM CUT OUT

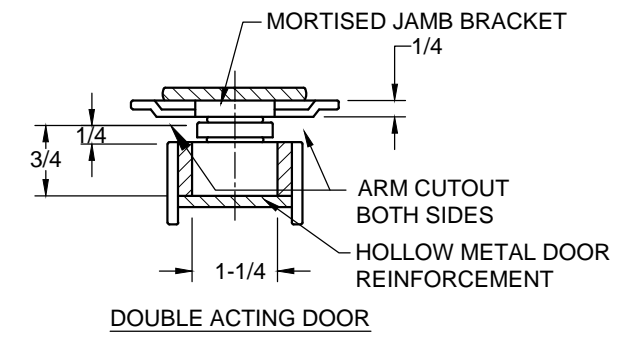
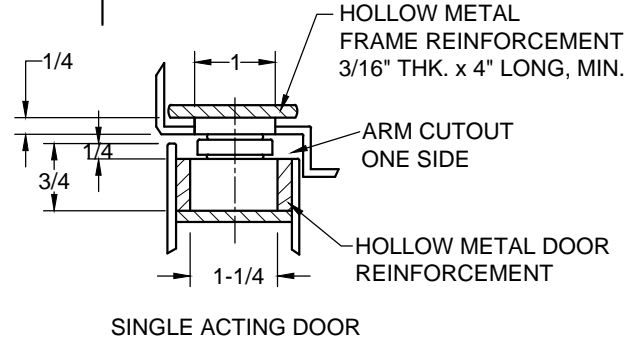
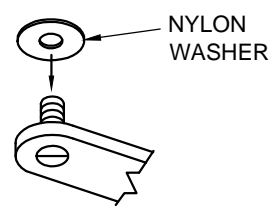
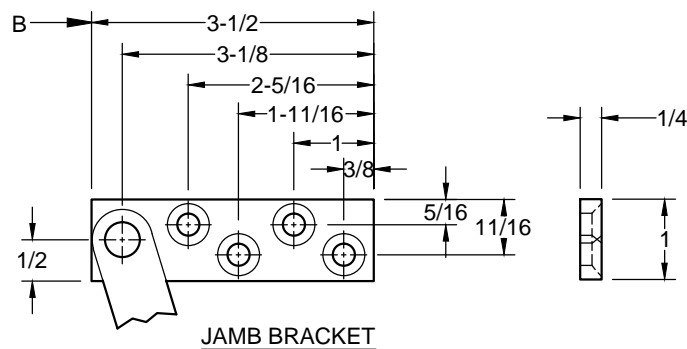

1000 SLT REPLACES THE JAMB BRACKET WITH A THREADED NYLON JAMB PIVOT SCREW, ADD 3/8" TO B DIM. DRILL & TAP FRAME FOR 3/8-24 M.S. NO FRAME PREP NEEDED. NOTE: 1/4" OR GREATER REINFORCEMENT RECOMMENDED

SCREW DETAIL			
	QTY	WOOD	METAL
JAMB	4	#14 x 1-1/2 FLAT HEAD WOOD SCREW	1/4-20 x 3/4 FLAT HEAD MACHINE SCREW
DOOR	2	#18 x 2-1/2 FLAT HEAD WOOD SCREW	5/16-18 x 1-1/2 FLAT HEAD MACHINE SCREW

- NOTES:**
1. REVERSIBLE/ NON - HANDED
 2. FOR SINGLE OR DOUBLE ACTING DOORS
 3. ALWAYS REQUEST LATEST TEMPLATE/ DRAWING FOR NEW INSTALLATIONS.
 4. ALL DIMENSIONS ARE IN INCHES.
 5. DRAWING IS NOT TO SCALE.
 6. ALL DRILLING AND TAPPING TO BE DONE IN FIELD.

1000SL-1-09.DWG

1000SL SERIES CONCEALED HOLDERS & STOPS

● 1010SL HOLD-OPEN ● 1020SL STOP

1. FOR 1000SLT ADD 3/8" TO "B" DIMENSION
 2. FOR DEAD STOP ADD 7/8" TO "A" DIMENSION.

3. ALL DIMENSIONS ARE IN INCHES.
 4. * BUTT HINGE ONLY

DOOR THICKNESS 1-3/4" TO 2-1/4"	DEGREE		85° H.O.				90° H.O.				95° H.O.				D
	MODEL NO.	DOOR OPENING	A	B	C	E	A	B	C	E	A	B	C	E	
	● 1011SL ● 1021SL	27 TO 29-15/16	6-1/8	6-1/8	5-1/2	16-7/8	5-11/16	5-11/16	5	16-7/8	5-3/8	5-3/8	4-1/2	17-1/8	
● 1012SL ● 1022SL	30 TO 35-15/16	7-3/8	7-3/8	6-3/4	18-5/16	6-15/16	6-15/16	6-1/4	18-3/8	6-1/2	6-1/2	5-3/4	18-7/16	18-13/16	
● 1013SL ● 1023SL	36 TO 39-15/16	11-5/8	8-9/16	6-3/4	22-7/8	11-1/16	8	7-1/4	22-7/8	10-5/8	7-9/16	6-3/4	22-7/8	20-1/8	
● 1014SL ● 1024SL	40 TO 43-15/16	14-7/16	9-5/8	9	25-5/8	13-7/8	9-1/16	8-1/4	25-7/8	13-5/16	8-1/2	7-3/4	25-3/4	21-5/16	
● 1015SL ● 1025SL	44 TO 52	17-5/16	10-11/16	10	28-5/8	16-5/8	10	9-1/4	28-5/8	16-1/16	9-7/16	8-3/4	28-5/8	22-7/16	

BUTT/SWING CLEAR & OFFSET PIVOT	DEGREE		100° H.O.				105° H.O.				110° H.O.				D
	MODEL NO.	DOOR OPENING	A	B	C	E	A	B	C	E	A	B	C	E	
	● 1011SL ● 1021SL	27 TO 29-15/16	* 5-1/16	* 4-11/16	* 2	* 19-5/16	—	—	—	—	—	—	—	—	
● 1012SL ● 1022SL	30 TO 35-15/16	6-3/16	6-3/16	5-1/2	18-3/8	5-7/8	5-7/8	3-13/16	19-3/4	* 5-5/8	* 5-5/8	* 1	* 22-5/16	18-13/16	
● 1013SL ● 1023SL	36 TO 39-15/16	10-3/16	7-1/8	6-1/2	22-3/4	9-13/16	6-3/4	6	22-3/4	9-1/2	6-7/16	5	23-1/2	20-1/8	
● 1014SL ● 1024SL	40 TO 43-15/16	12-13/16	8	7-1/4	25-3/4	12-7/16	7-5/8	7	25-5/8	12-1/16	7-1/4	6-1/2	25-3/4	21-5/16	
● 1015SL ● 1025SL	44 TO 52	15-1/2	8-7/8	8	28-13/16	15-1/16	8-7/16	7-3/4	28-5/8	14-11/16	8-1/16	7-1/4	28-3/4	22-7/16	

CENTER HUNG	DEGREE		85° H.O.				90° H.O.				95° H.O.				D
	MODEL NO.	DOOR OPENING	A	B	C	E	A	B	C	E	A	B	C	E	
	● 1011SL ● 1021SL	30 TO 32-15/16	6-7/8	6-7/8	6-1/4	16-7/8	6-7/16	6-7/16	5-3/4	16-7/8	6-1/8	6-1/8	5-3/8	16-7/8	
● 1012SL ● 1022SL	33 TO 38-15/16	8	8	7-1/4	18-7/16	7-1/2	7-1/2	6-3/4	18-7/16	7-1/8	7-1/8	6-1/2	18-5/16	18-13/16	
● 1013SL ● 1023SL	39- TO 42-15/16	12-5/16	9-1/4	8-1/2	22-7/8	11-3/4	8-11/16	8	22-3/4	11-1/4	8-3/16	7-1/2	22-3/4	20-1/8	
● 1014SL ● 1024SL	43 TO 46-15/16	15-1/4	10-7/16	9-3/4	25-3/4	14-9/16	9-3/4	9	25-3/4	14	9-3/16	8-1/2	25-3/4	21-5/16	
● 1015SL ● 1025SL	47 TO 54	18-1/8	11-1/2	10-3/4	28-3/4	17-3/8	10-3/4	10	28-3/4	16-3/4	10-1/8	9-1/2	28-5/8	22-7/16	

CENTER HUNG	DEGREE		100° H.O.				105° H.O.				110° H.O.				D
	MODEL NO.	DOOR OPENING	A	B	C	E	A	B	C	E	A	B	C	E	
	● 1011SL ● 1021SL	30 TO 32-15/16	—	—	—	—	—	—	—	—	—	—	—	—	
● 1012SL ● 1022SL	33 TO 38-15/16	6-11/16	6-11/16	6	18-3/8	6-3/8	6-3/8	5-3/4	18-5/16	6-1/8	6-1/8	5-1/2	18-5/16	18-13/16	
● 1013SL ● 1023SL	39- TO 42-15/16	10-13/16	7-3/4	7-1/8	22-3/4	10-7/16	7-3/8	6-3/4	22-3/4	10-1/8	7-1/16	6-3/8	22-3/4	20-1/8	
● 1014SL ● 1024SL	43 TO 46-15/16	13-9/16	8-3/4	8	25-3/4	13-1/8	8-5/16	7-1/2	25-3/4	12-3/4	7-9/16	7-1/4	25-3/4	21-5/16	
● 1015SL ● 1025SL	47 TO 54	16-1/4	9-5/8	9	28-5/8	15-3/4	9-1/8	8-1/2	28-5/8	15-5/16	8-11/16	8	28-5/8	22-7/16	



www.abhmfg.com
 E-mail: abhinfo@abhmfg.com
 Architectural Builders Hardware Mfg., Inc.
 1222 Ardmore Ave., Itasca, IL 60143
 630.875.9900; FAX 800.9FAXABH (932.9224)

©2017 ABH Mfg., Inc.
 printed in USA

1000SL

PAGE 2 OF 2
 REVISED 05-02-17