



Small Footprint Rotational Dual Station Welding Robotic System



Quick installation with fully mounted on common base and optimized working area.

Designed for medium productivity with variable lots

Easy to movedoor

Easy integration with any robot brand and welding inverter.



Dual workstations with guide bushes for positioning and safety devices, in compliance with ANSI/RIA 15.06 Standard.

Ready-To-Weld robotic welding system offers the best cost benefit ratio. Designed for welding of medium size parts and where shop space maybe an issue. Increase your productivity easily and quickly, allowing an easy integration with any robot brand and welding inverter.

All inclusive Package



+



+



Tabletop dimensions	21" x 42"
Maximum table load capacity	440 lb
Maximum cell power requirements	66A
Input Voltage/Current	200V to 240V (three-phase)
Cell Dimensions	79" L x 118" W x 83" H
Weight	5000 lb
Power requirement	230V 70A / 460V 50A
Air Requirements/Flow Rate	87 Psi/0.59 Cfm

Measures

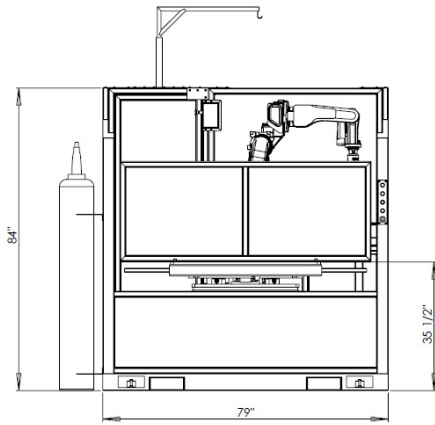

Front

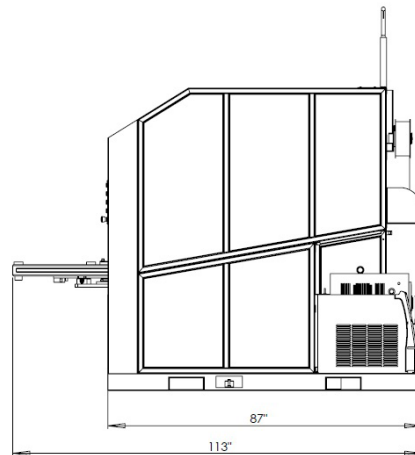

Side

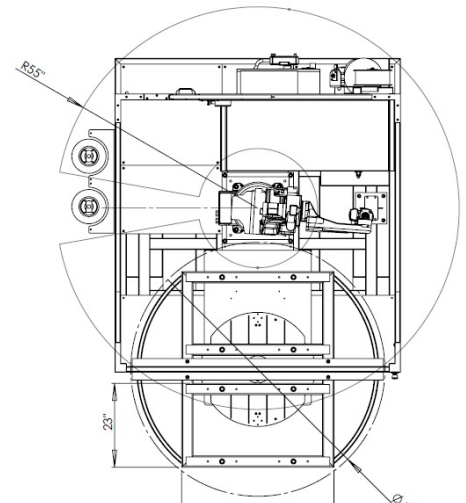

Working Area

Standard Components



6 axis



400 Amp Inverter



400 Amp Air Cooled Torch with Safety Clutch

Optionals

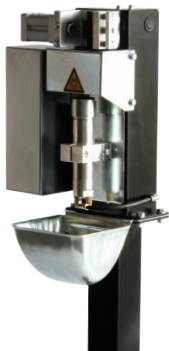

Torch Cleaner and Wire Cutter Unit

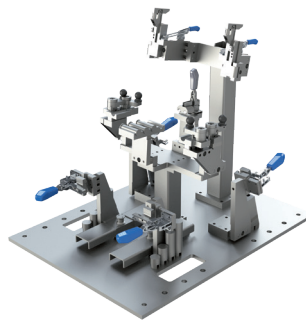

Tooling



Turn Table



SUMIG USA CORPORATION
8600 Commodity Circle #159
Orlando, FL 32819

☎ +1 800 503 9717
🌐 www.sumigusa.com
✉ sumigusa@sumig.com