



THE ROBOTIC WELDING SPECIALISTS

# RTW-SS67

Single Station Welding Cell with Dual Station Option





*Sumig specializes in robotics welding and has the solution for your company*



*Programming and operation friendly*



*Ready to Weld*



*Optimized Workspace*



*All steel construction for safety and quality*



**FAST SERVICE AND SUPPORT**

**INDUSTRY 4.0 PREPARED**

Our **RTW-SS67** is the ideal cell for those who seek higher performance in welding combining it with a medium investment. Single Station Welding Cell with Dual Station Option.

Sumig's newly designed **Ready-To-Weld (RTW)** modular cells systems line offers the highest scalability and configurable options in the market today. Our standard robotic welding systems includes world class robotic arms and power sources to meet your welding application, productivity and quality goals. The modular design concept allows for future expansion as your business grows.

## Technical Data

Workstation Dimensions	30" x 59"
Max load capacity	2205 lb
Input Power Ratings	47 Amps @ 240V 3PH 23 Amps @ 460V 3PH
Cell Dimensions	83.5" height x 88.6" width x 88.6" depth
Weight	4410 lb
Air Requirement	87 Psi. @ 20 CFM
Size in ft <sup>2</sup>	61 ft <sup>2</sup>

### Turn Key Systems Includes:

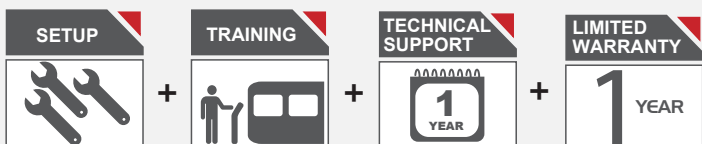

## Measurements

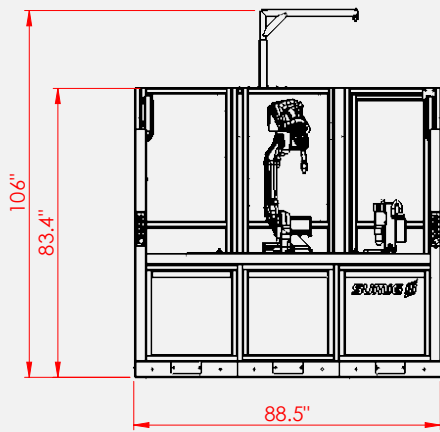

Front

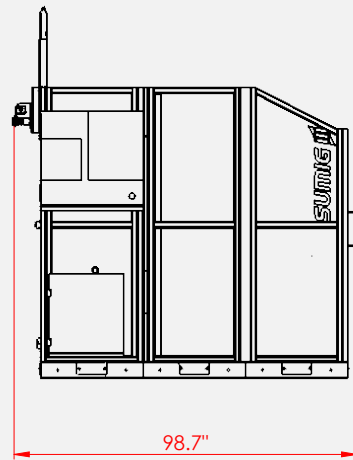

Side

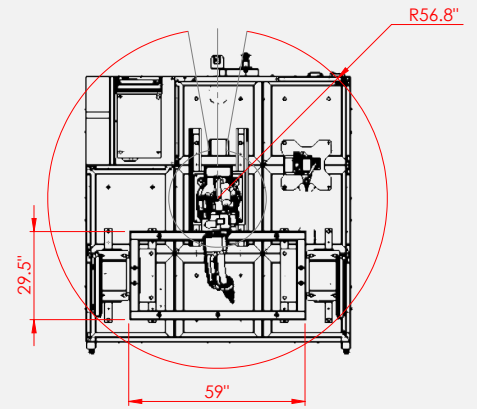

Working Area

## Standard Components



Robot 6 Axis  
2.0 Meter Reach



Power Source  
Pulse MIG - Pulse TIG



SU 477 Robotic  
Welding Torch  
Air Cooled or Water Cooled

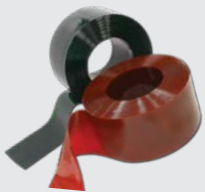

Safety Light Barriers  
Welding Screen  
Between Stations



Maintenance door



Robot Controller

Entire process can be automated, not only welding, but toolings, positioners, manipulators, among others. Reach us out and learn more about these components.

## Optionals



Cleaning Unit

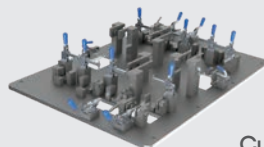

Custom Automatic  
or Manual Tooling

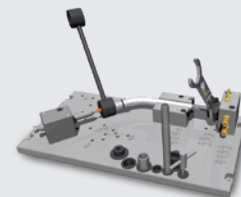

Torch TCP  
Calibration Tool



Drum Kit

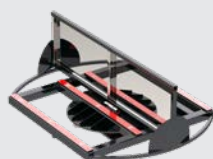

Table to dual  
station



FastFind  
Laser Sensor

LOOKING FOR A WAY  
TO BOOST YOUR  
PRODUCTION?  
**CALL US TODAY!**

**SUMIG GLOBAL  
PRESENCE**

[WWW.SUMIGUSA.COM](http://WWW.SUMIGUSA.COM)

1504 EAGLE CT. STE 8 - LEWISVILLE, TX, 75057  
PHONE: +1(800) 503 9717 - [SUMIGUSA@SUMIG.COM](mailto:SUMIGUSA@SUMIG.COM)

FOLLOW OUR SOCIAL MEDIA

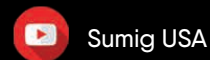

**SUMIG III**