

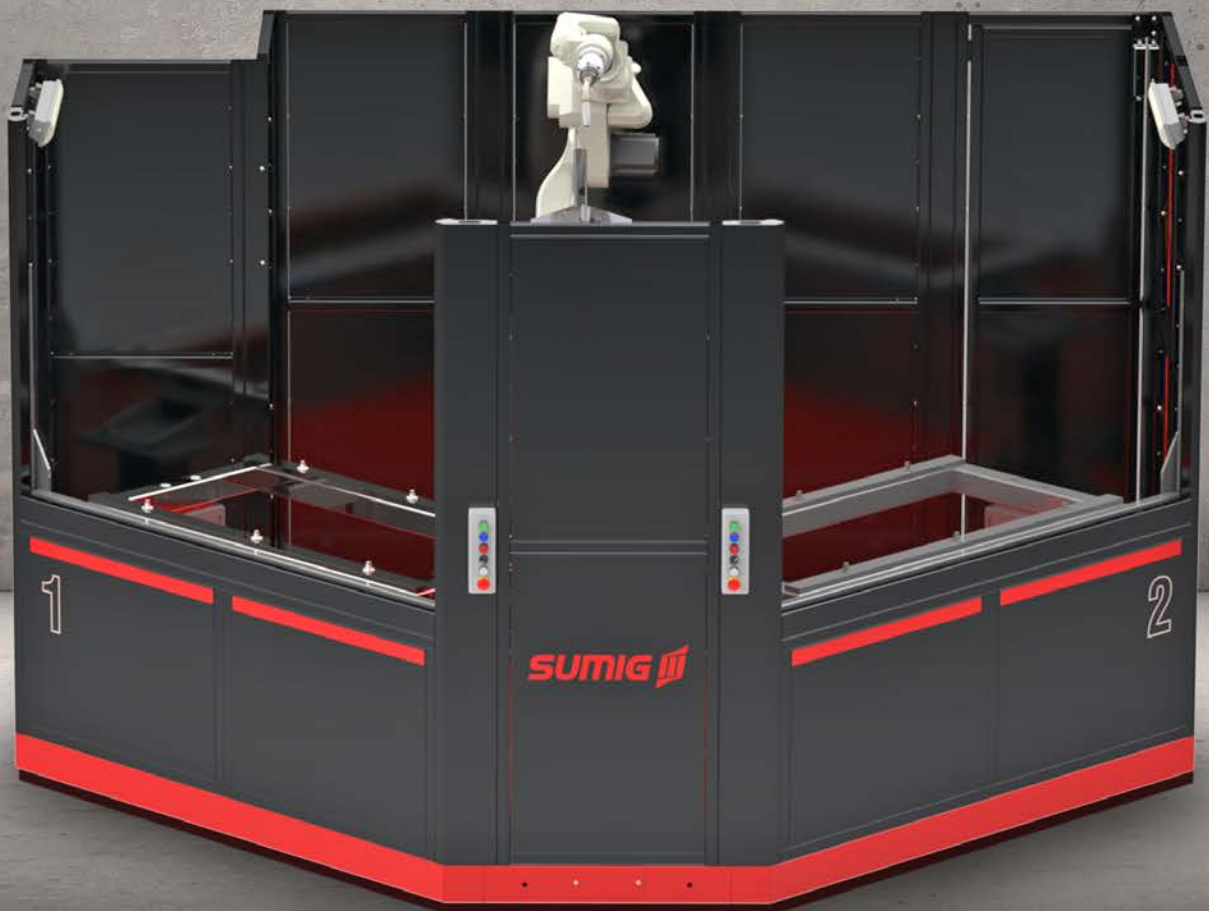

THE ROBOTIC WELDING SPECIALISTS

# RTW-LA60

Dual frontal feeding welding cell. Fixed  
or rotating tables





*Sumig specializes in robotics welding and has the solution for your company*



*Programming and operation friendly*



*Ready to Weld*



*Optimized Workspace*



*All steel construction for safety and quality*



**FAST SERVICE AND SUPPORT**

**INDUSTRY 4.0 PREPARED**

Our **RTW-LA60** is a dual frontal feeding welding cell. It has two 45° working stations. Fixed or rotating tables.

Sumig's newly designed **Ready-To-Weld (RTW)** modular cells systems line offers the highest scalability and configurable options in the market today. Our standard robotic welding systems includes world class robotic arms and power sources to meet your welding application, productivity and quality goals. The modular design concept allows for future expansion as your business grows.

## Technical Data

Workstation Dimensions	29.5" x 59"
Max load capacity	2204,62 lb
Input Power Ratings	63 Amps @ 240V 3PH 50 Amps @ 460V 3PH
Cell Dimensions	83.4" height x 129.7" depth
Weight	6613,86 lb
Air Requirement	87 Psi.@ 20 CFM
Size in ft <sup>2</sup>	129 ft <sup>2</sup>

### Turn Key Systems Includes:

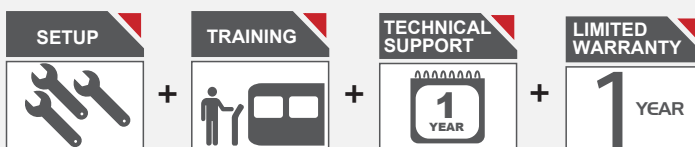

## Measurements

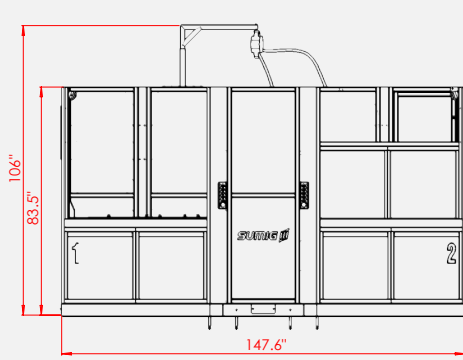

Front

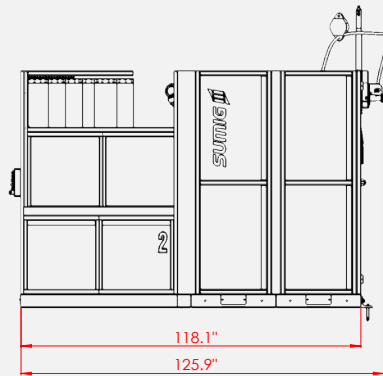

Side

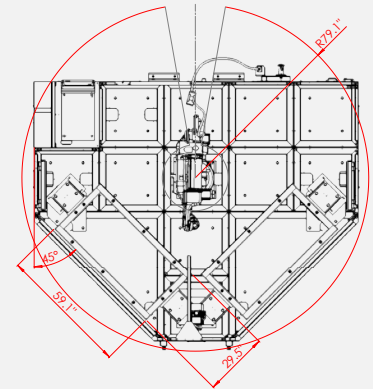

Working Area

## Standard Components



Robot 6 Axis  
2.0 Meter Reach



Power Source  
Pulse MIG - Pulse TIG



SU 477 Robotic  
Welding Torch  
Air Cooled or Water Cooled

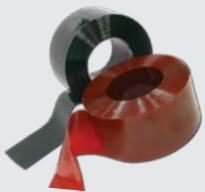

Safety Light Barriers  
Welding Screen  
Between Stations



Maintenance door



Robot Controller

Entire process can be automated, not only welding, but toolings, positioners, manipulators, among others. Reach us out and learn more about these components.

## Optionals



Cleaning Unit

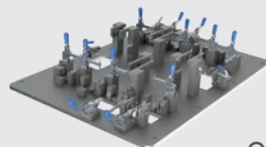

Custom Automatic  
or Manual Tooling

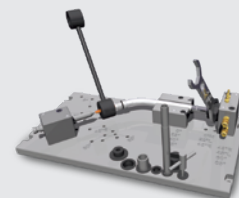

Torch TCP  
Calibration Tool



Drum Kit

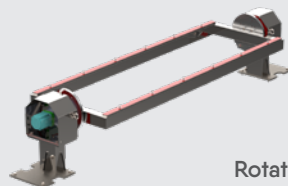

Rotational Tables  
or Fixed Stations



FastFind  
Laser Sensor

LOOKING FOR A WAY  
TO BOOST YOUR  
PRODUCTION?  
**CALL US TODAY!**

**SUMIG GLOBAL  
PRESENCE**

[WWW.SUMIGUSA.COM](http://WWW.SUMIGUSA.COM)

1504 EAGLE CT. STE 8 - LEWISVILLE, TX, 75057  
PHONE: +1(800) 503 9717 - [SUMIGUSA@SUMIG.COM](mailto:SUMIGUSA@SUMIG.COM)

FOLLOW OUR SOCIAL MEDIA

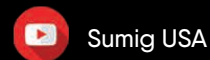

**SUMIG III**