

2014-2024 TOYOTA 4RUNNER HILINE BUMPER HIGH CLEARANCE SIDE WINGS PART# TR-19339W

PARTS LIST:

1	Hiline Driver/Left Wing	2	10mm x 30mm Double Bolt Plates
1	Hiline Passenger/Right Wing	2	10mm x 30mm Single Bolt Plates
1	Washer Reservoir Cover Plate	6	10mm x 30mm x 2.5mm Flat Washers
1	Driver/Left Mounting Bracket	6	10mm Lock Washers
1	Passenger/Right Mounting Bracket	6	10mm Hex Nuts
4	LED "L" Light Brackets	4	6-1.0mm x 20mm Hex Bolts
1	Long Edge Trim	8	6mm x 12mm x 1.6mm Flat Washers
2	Short Edge Trim	4	6mm Nylon Lock Nuts
6	10mm Plastic Retainers		

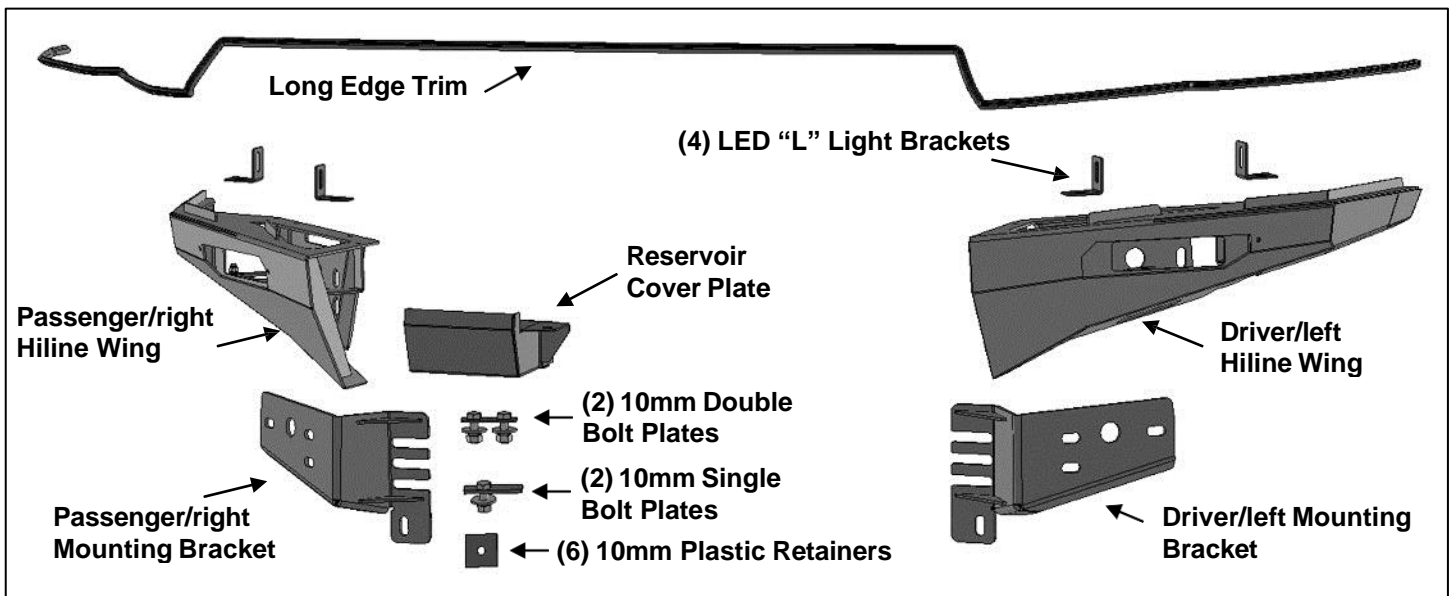

PROCEDURE:

REMOVE CONTENTS FROM BOX. VERIFY ALL PARTS ARE PRESENT. READ INSTRUCTIONS CAREFULLY BEFORE STARTING INSTALLATION. CUTTING OE FRONT BUMPER IS REQUIRED.

1. Open the hood and remove the plastic cover from the top of the radiator and grille, **(Figure 1)**. Next, carefully remove the plastic grille.
2. Move to the driver/left side of the plastic bumper cover. Locate the ridge in the top right corner of the Hiline Bumper, **(Figure 2)**. Place a mark on the plastic cover 3/8"-1/2" below the ridge. Use removable tape to make a straight and level line along the bumper cover to the wheel opening, **(Figures 3 & 4)**. Place a mark 1" up from the tape at the wheel opening. **NOTE:** when installed, the Hiline Wings angle slightly upward at the ends.
3. Remove the hardware along the inside of the driver/left front of the wheel well attaching the bumper cover the inner fender liner, **(Figure 5)**.
4. Repeat **Steps 2 & 3** to mark the bumper cover and release the end of the cover.
5. On models with factory fog lights, unplug the harness leading to the bumper.
6. Remove the hardware attaching the plastic bumper cover at the top, ends and bottom, **(Figure 6)**. With assistance, pop the ends off of the inner clip and pull the bumper off and away from the vehicle. Set the plastic bumper cover on a soft, clean and flat surface.

7. Remove the outer (3) factory hex bolts attaching the driver/left Hiline Bumper Bracket to the frame, **(Figure 7)**. Also remove the hardware attaching the Support Bracket to the bottom of the Bumper Bracket.
8. Select the driver/left Wing Mounting Bracket, **(Figure 8)**. Reuse the (3) factory hex bolts and Support Bracket hardware to attach the Mounting Bracket over the Hiline Bumper Bracket, **(Figure 9)**. Line up the center of the slots in the Wing Mounting Bracket with the hardware and fully tighten hardware.
NOTE: To avoid readjustment to Hiline Bumper location on vehicle, only install one Mounting Bracket at a time. Adjust final width and position of Brackets and Wings after installation is complete, **(Step 18)**. Repeat this **Step** to attach the passenger/right side Mounting Bracket.
9. Select the driver/left Wing assembly. Insert (1) 10mm Double Bolt Plate into and out the inner mounting slots in the mounting plate on the back of the Wing, **(Figures 10 & 12)**. Thread (2) 10mm Plastic Retainers onto the Bolt Plate to help hold in place. Repeat this **Step** to insert (1) 10mm Single Bolt Plate into and out the outer hole in the back of the Wing, **(Figures 11 & 12)**. **NOTE:** Plastic Retainers are included to help hold the Bolt Plates in place but are not mandatory for Wing installation.
10. Determine if LED lights will be installed and design of lights at this time. Note lights are not included.
If no lights will be installed at this time, skip to Step 11.
Center bolt type light installation:
 - a. Attach light to slot in center of inner mounting plate in Wing assembly, **(Figure 13)**. Repeat to install remaining light.**End mount type light installation:**
 - a. Select (1) LED "L" Bracket. Attach the Bracket to the inner hole in the mounting plate in the Wing with the included (1) 6mm x 20mm Hex Bolt, (2) 6mm Flat Washers and (1) 6mm Nylon Lock Nut, **(Figure 13)**.
 - b. Repeat previous **Step** to attach (1) LED "L" Bracket to the outer hole in the mounting plate in the Wing, **(Figure 13)**.
 - c. Attach light to the "L" Brackets.
11. Attach the driver/left Wing assembly to the Mounting Bracket with (3) 10mm Flat Washers, (3) 10mm Lock Washers and (3) 10mm Hex Nuts, **(Figures 14 & 15)**. Snug but do not fully tighten hardware.
NOTE: Included rubber trim can be applied to the inner edge of the Wing assembly but is not required to complete installation. Rubber Trim may be used to fine tune the completed look of your build and installation is optional.
12. Repeat **Steps 9—11** to assemble and install the passenger/right Wing assembly.
13. Use a sharp knife or hacksaw blade to carefully cut along the previously marked lines on the bumper cover, **(Figures 4 & 16)**. **IMPORTANT:** The previous directions for marking the line will leave an extra 1/4" or more of material when cutting to make any adjustments at the end of the installation as necessary.
14. Reinstall the cut plastic bumper cover and trim cover as necessary for best fit to Hiline Wings.
15. Once all trimming is completed, remove any rough edges along the cut bumper and cover the cut edge of the bumper cover with the included long Edge Trim, **(Figures 16 & 20)**. Cut the ends of the Edge Trim to fit as required.
16. Check fitment of Bumper and adjust the Wing location in or out as needed and tighten the Bracket to frame hardware. Adjust the passenger/right side to match and fully tighten all hardware.
17. Reinstall the grille and top plastic cover.
18. Remove the hex nut from the bottom of the passenger/right front body mount, **(Figure 17)**. Select the Washer Reservoir Cover, **(Figure 18)**. Reuse the hardware to attach the Cover to the bottom of the body mount, **(Figure 19)**.
19. Do periodic inspections to the installation to make sure that all hardware is secure and tight.

To protect your investment, Do not use any type of polish or wax that may contain abrasives that could damage the finish. Mild soap may be used to clean the Hiline Wings.

Driver/left Side Installation Pictured

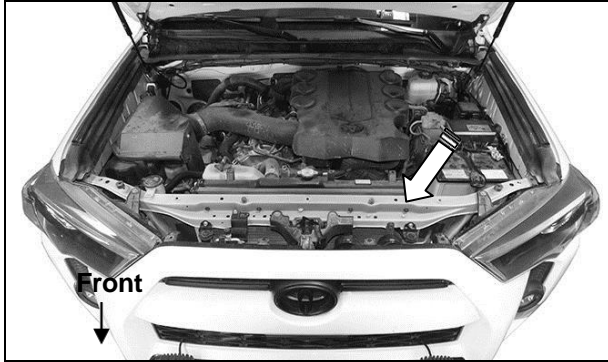

(Fig 3) Cover the top of the bumper with removable tape (masking tape for example)

(Fig 1) Remove the plastic cover from the top of the radiator. Remove grille assembly

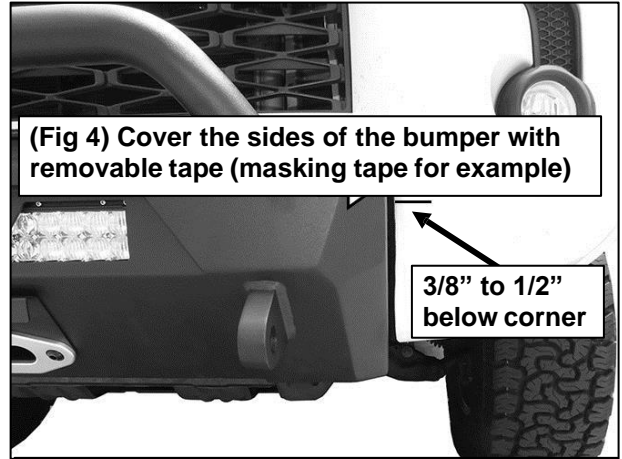

(Fig 4) Cover the sides of the bumper with removable tape (masking tape for example)

3/8" to 1/2" below corner

(Fig 2) Locate corner on top right corner of Hiline Bumper (arrow). Place mark 3/8" to 1/2" below corner for a starting point

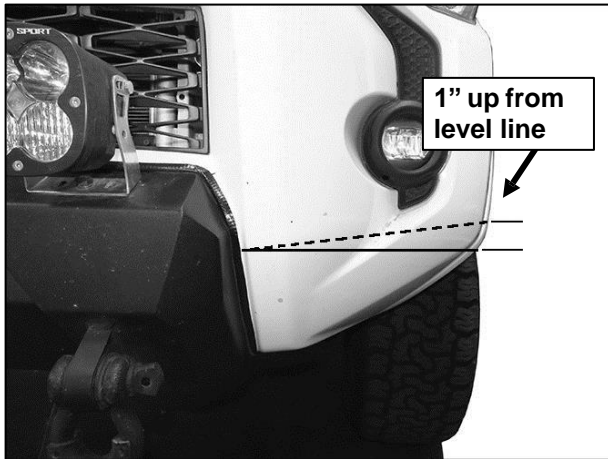

1" up from level line

(Fig 3) Use masking tape to make a straight and level line from the mark (see Fig 2) to the wheel opening (solid line). Measure up 1" from level line (arrow)



(Fig 4) Masking tape used to make a straight line from the front mark to the wheel opening. Follow bottom edge of masking tape

Driver/left Side Installation Pictured

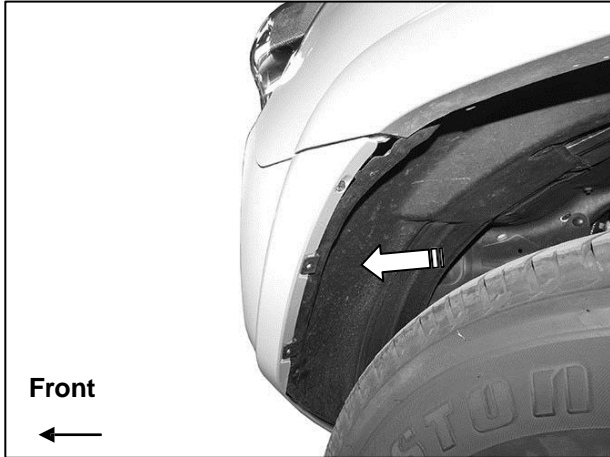

(Fig 5) Remove the hardware along the inside of the wheel well to release the end of the bumper cover

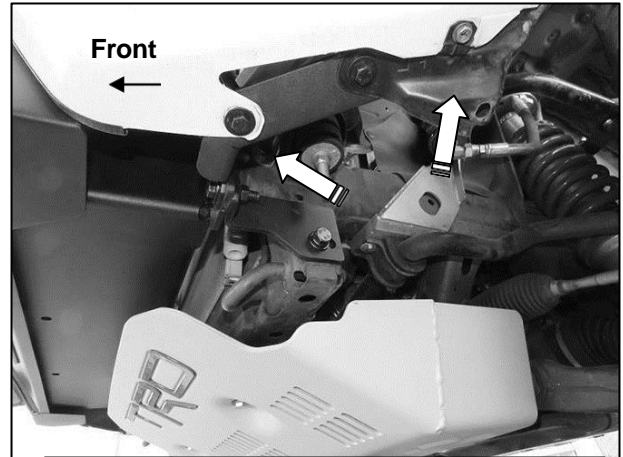

(Fig 6) Remove hardware along top and bottom of bumper cover (bottom pictured)

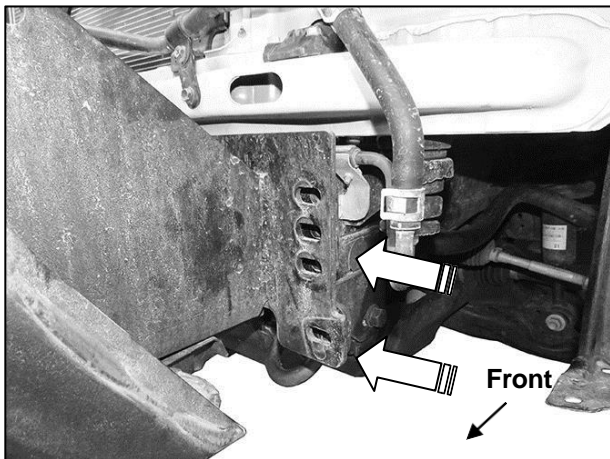

(Fig 7) Remove the outer hardware attaching the driver/left Hiline Bumper Bracket and Support Bracket to the frame (arrows)

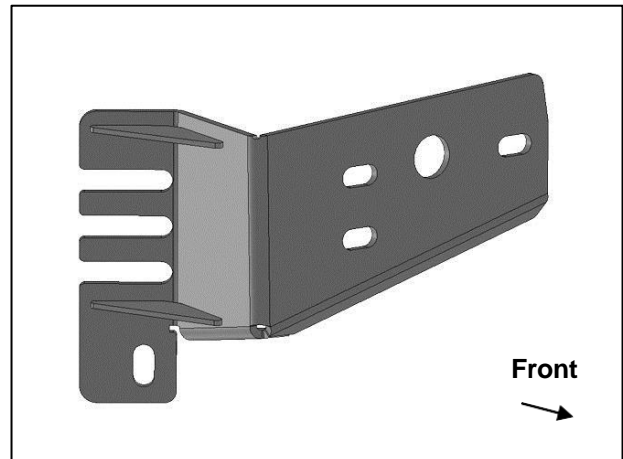

(Fig 8) Driver/left Wing Mounting Bracket

Driver/left Side Installation Pictured

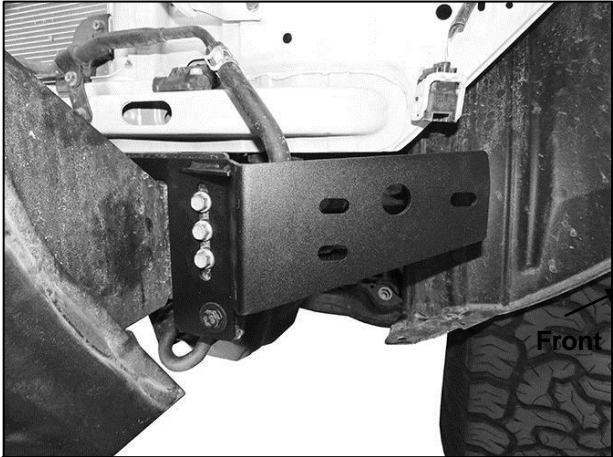

(Fig 9) Reuse the bumper hardware to attach the Mounting Bracket to the bumper bracket and frame

(2) 10mm Plastic Retainers

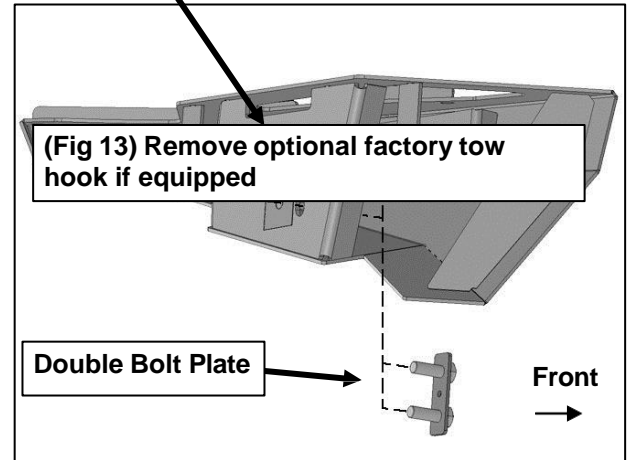

(Fig 10) Insert (1) Double Bolt Plate into and through inner slots in Wing assembly

10mm Plastic Retainer

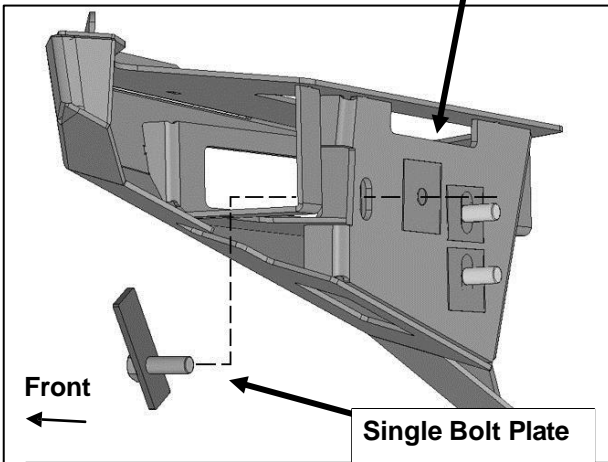

(Fig 11) Insert (1) Single Bolt Plate into and through outer slot in Wing assembly

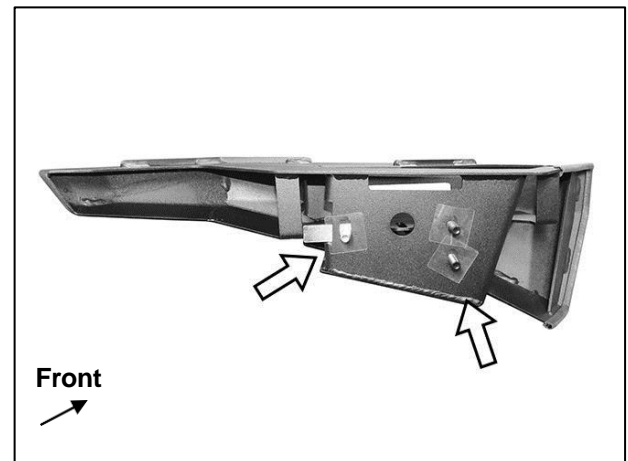

(Fig 12) Tighten Plastic Retainers (arrows) to hold bolt Plates in place

Driver/left Side Installation Pictured

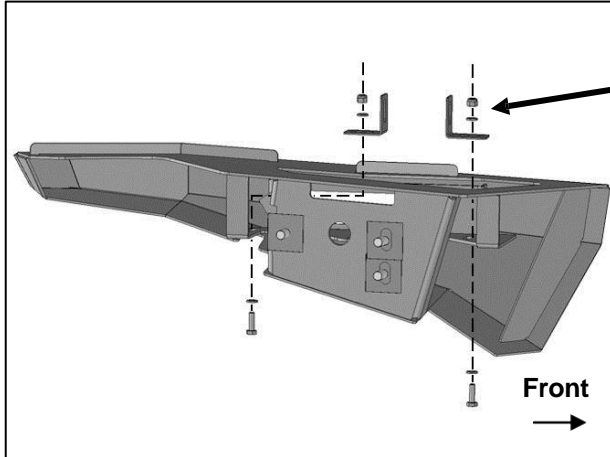

- (2) 6mm x 20mm Hex Bolts
- (4) 6mm Flat Washers
- (2) 6mm Nylon Lock Nuts

- (3) 10mm Flat Washers
- (3) 10mm Lock Washers
- (3) 10mm Hex Nuts

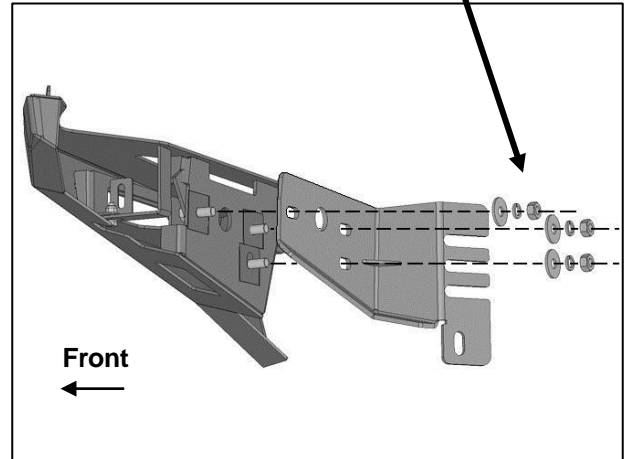

(Fig 13) To install lights with end mounts, attach "L" Brackets to mounting plate in Wing and attach light to "L" Brackets. Lights with top or bottom stud mount, attach light directly to mounting tabs, "L" Brackets not required (lights not included)

(Fig 14) Attach Wing to Mounting Bracket



(Fig 15) Driver/left Wing installed

After final trimming, apply Long Edge Trim to bottom of center and ends of bumper cover. Cut Edge Trim to fit cover

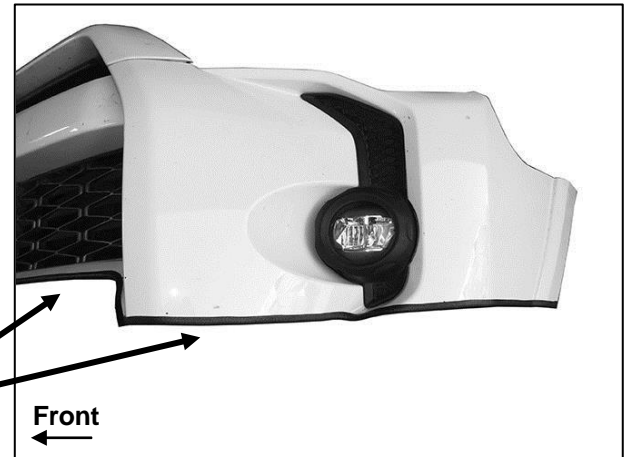

(Fig 16) Driver/left side of bumper cover cut pictured. Push Edge Trim onto cover and reinstall the bumper cover

Driver/left Side Installation Pictured

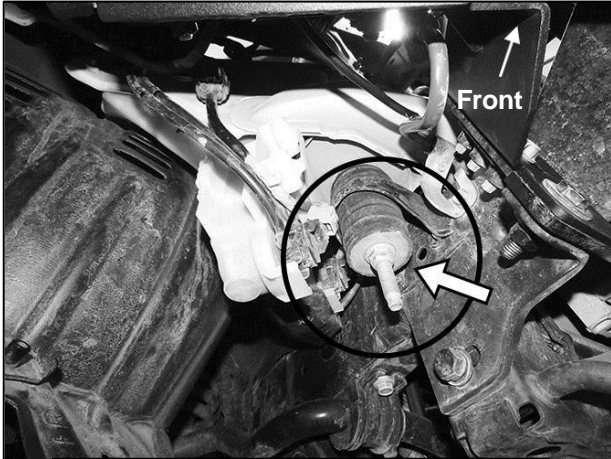

(Fig 17) Remove hex nut from bottom of passenger/right front body mount

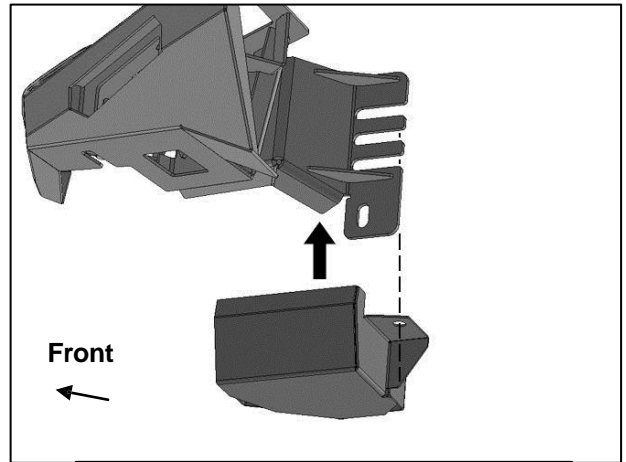

(Fig 18) Reuse hex nut to attach windshield washer reservoir cover to bottom of body mount (see Fig 17)

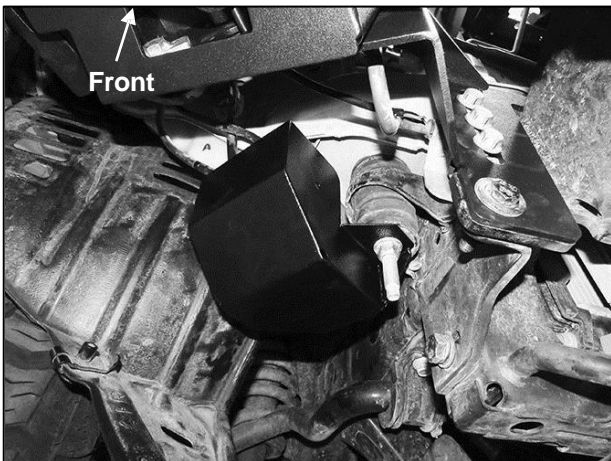

(Fig 19) Windshield washer reservoir Cover installed

Trim bottom of bumper if necessary for desired fit

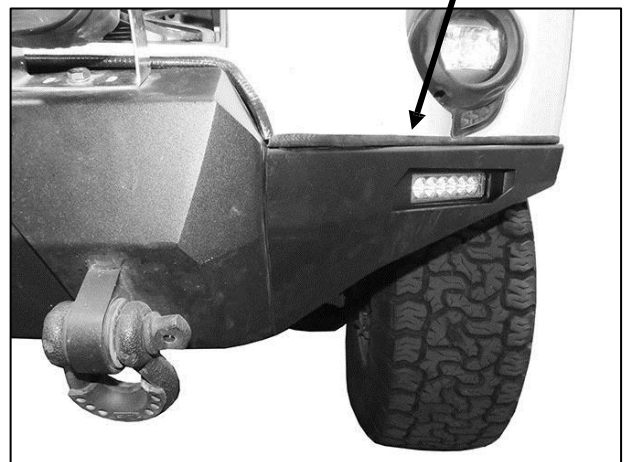

(Fig 20) Passenger/right side of bumper cover cut to fit Hiline Wing