

# RTS82FD

# 1999-2016 Ford Superduty Crew Cab RTS82FD Installation Instructions

## Hardware Kit Includes Loose:

- (1) 24 – Hex head bolts (M8-1.25 x 30mm) Grade 8
- (2) 24 – Lock washers (M8) Grade 8
- (3) 42 – Flat washers (M8) Grade 8
- (4) 6 – Lrg. M8-1.25 U-Clip (#18401)
- (5) 18 – Hex head nuts (M8-1.25) Grade 8

## Hardware Installed at ICI:

- (1) 24–Button head Allen head bolt (M5-1.0x16mmSS) #200308878
- (2) 24– Serrated hex head flanged nuts (M5-1.0 SS) #200391166

## Components List:

- (1) 2 – Heavy Duty RT Steps
- (2) 6 –Mounting Brackets RTSPN017

**LOOSE FIT ALL COMPONENTS.  
DO NOT TIGHTEN UNTIL ALL  
COMPONENTS ARE INSTALLED  
AND ADJUSTED.**

**DISCLAIMER: USE ONLY  
COMPONENTS AND HARDWARE  
SUPPLIED BY ICI.  
NO SUBSTITUTIONS.**

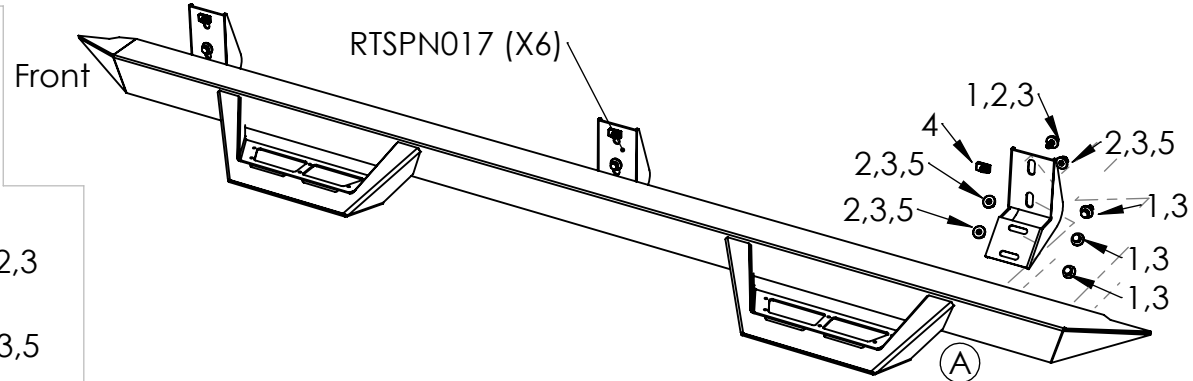
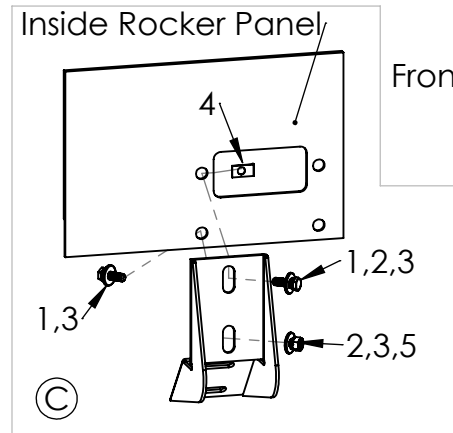
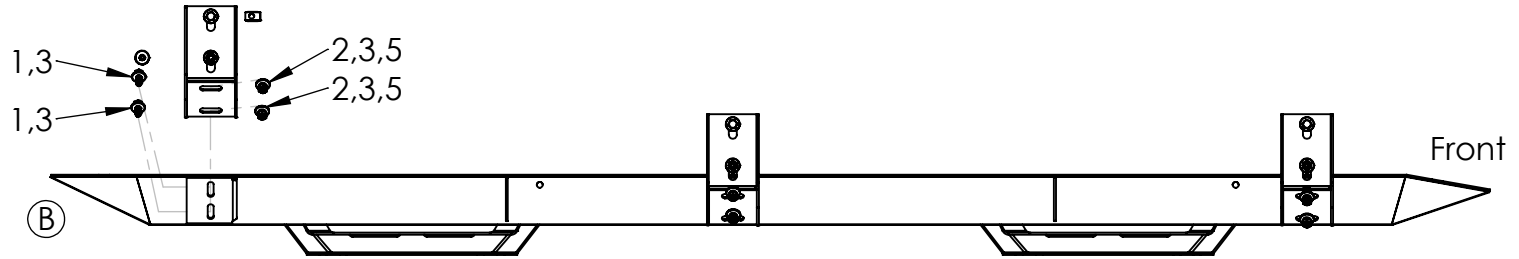

## Step by Step Installation Instructions

- STEP 1:** Read and understand instructions completely before beginning installation.
- STEP 2:** Remove all old steps and hardware from truck.
- STEP 3:** Locate the driver's side step (the bent down edge goes towards the front of the vehicle).
- STEP 4:** Insert the supplied U-Clip nuts into the holes on the inside of the rocker panel (holes may be covered by tape). Line up the top vertically slotted hole in RTSPN017 with the installed U-Clips and insert supplied 8mm bolt with flat washer and lock washer. The bottom vertically slotted hole should now line up with a hole in the pinch weld of the vehicle. Insert supplied 8mm bolt and flat washer from the outside of the vehicle through the pinch weld and through RTSPN017 then attach supplied flat washer, lock washer and 8mm nut. Hand tighten only. Refer to hole location on page 2 and figure C.
- STEP 5:** Loose fit remaining RTSPN017 brackets to rocker panel using supplied 8mm hardware. Refer to figure C.
- STEP 6:** Once brackets are loose fit, mount bar to brackets using supplied 8mm bolts, flat washers, lock washers and nuts, and then finger tighten. Two 8mm bolts, four flat washers, two lock washers and two nuts hold each RTSPN017 to the step bar. It is easiest to insert the bolts from inside the bar through RTSPN017, see figure B.
- STEP 7:** Once step is loose fit, tighten brackets to inside rocker to 30 ft/lbs. Next, adjust bar up/down and front/back then tighten step to brackets at 30 ft/lbs. Repeat for passenger side.

# 1999-2016 Ford Superduty Crew Cab RTS82FD Installation Instructions

## Outside RT Step Bracket, Inside Rocker Locations for Ford Superduty

Looking at the pinch weld there are 10 holes long the length of the cab. The outside brackets for the RT step mount into the 2nd, 6th and 9th holes. Spacing between these holes is shown below.

