

RTS22FD



2015-17 Ford F150/2017 Superduty Crew Cab Installation Instructions

Hardware Kit Includes Loose:

- (1) 12 – Hex head bolts (M8-1.25 x 30mm) Grade 8
- (2) 30 – Lock washers (M8) Grade 8
- (3) 42 – Flat washers (M8) Grade 8
- (4) 30 – Hex head nuts (M8-1.25) Grade 8

Components List:

- (1) 2 – Heavy Duty RT Steps RTSPN039
1 Driver/1 Passenger
- (2) 6 – Mounting Brackets RTSPN040
3 Driver/3 Passenger
- (3) 6- Rubber Isolator (RTSPN044)
- (4) 6- Rubber Isolator (RTSPN045)

**LOOSE FIT ALL COMPONENTS.
DO NOT TIGHTEN UNTIL ALL
COMPONENTS ARE INSTALLED
AND ADJUSTED.**

**DISCLAIMER: USE ONLY
COMPONENTS AND HARDWARE
SUPPLIED BY ICI.
NO SUBSTITUTIONS.**

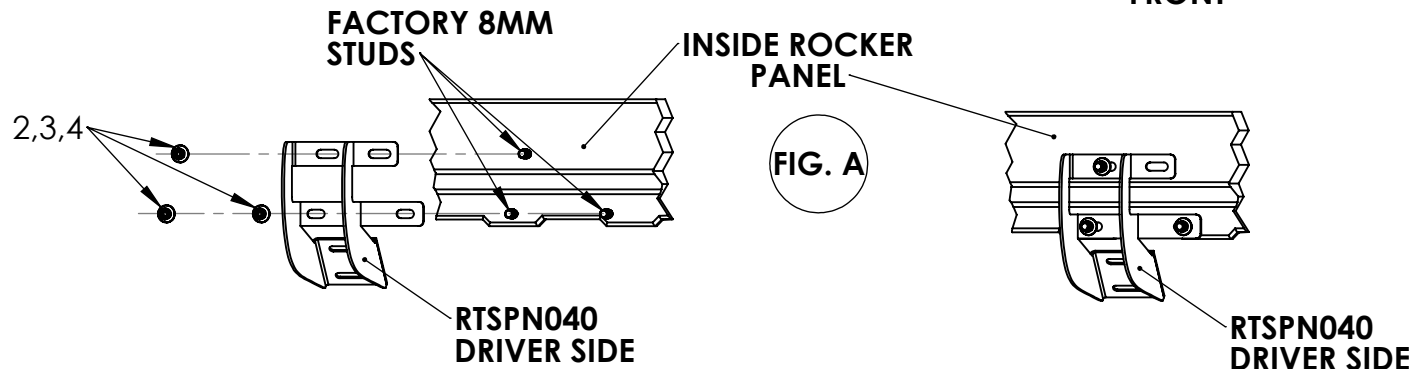
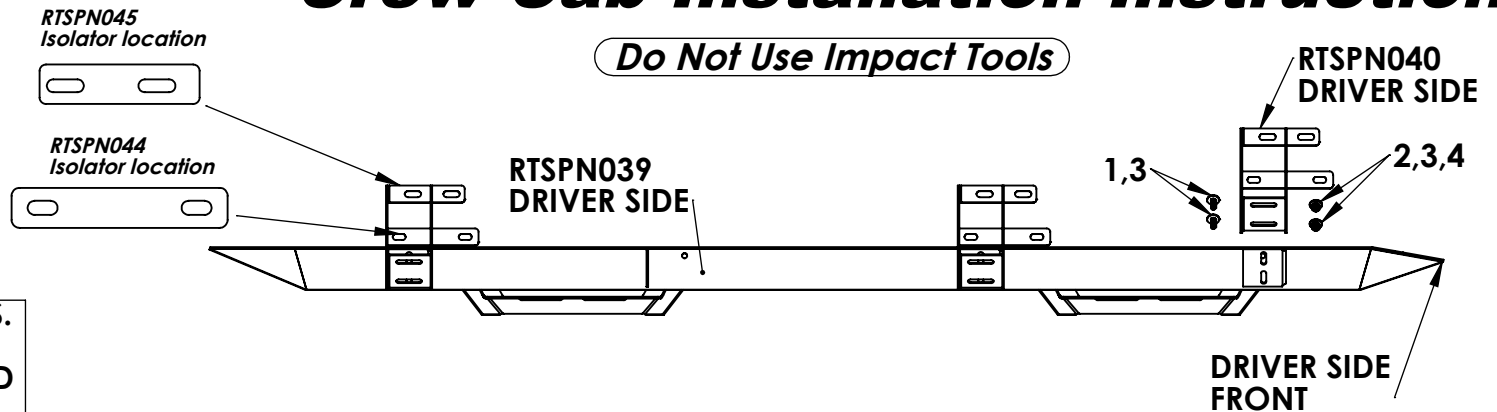

Step by Step Installation Instructions

- STEP 1:** Read and understand instructions completely before beginning installation.
- STEP 2:** Remove all old steps and hardware from truck.
- STEP 3:** Locate the driver's side step (the front of the step bar has a bend down and a notch on the inside top).
- STEP 4:** On the inside rocker panel there are three mounting points, each with (3) 8mm threaded studs coming out of the panel. Hang RTSPN040 mounting brackets from each of these three mounting points, aligning the studs with the mounting holes in each RTSPN040 bracket (FIG. A). Use provided 8mm nut, lock washer and flat washer for each stud. Use one (RTSPN045) Isolator in between bracket and body (Top holes) and one (RTSPN044) on bottom locations on all six brackets. The factory studs may be covered in paint and need to be cleaned before the 8mm nut will install. Be careful not to cross thread the nut on the studs. Do not tighten mounting brackets to truck until step is attached to mounting brackets and properly aligned.
- STEP 5:** Once RTSPN040 brackets are loose fit to the truck, attach step bar to brackets using supplied 8mm bolts, flat washers, lock washers and nuts. Do not tighten bar to brackets, leave finger tight. Once bar is loose fit to brackets, adjust brackets and tighten brackets to inside rocker of truck to 30 ft/lbs. **DO NOT USE IMPACT TOOLS.**
- STEP 6:** Next, adjust bar up/down and front/back then tighten step to brackets at 30 ft/lbs. **DO NOT USE IMPACT TOOLS.** Repeat for passenger side.

RTS22FD DRIVER SIDE

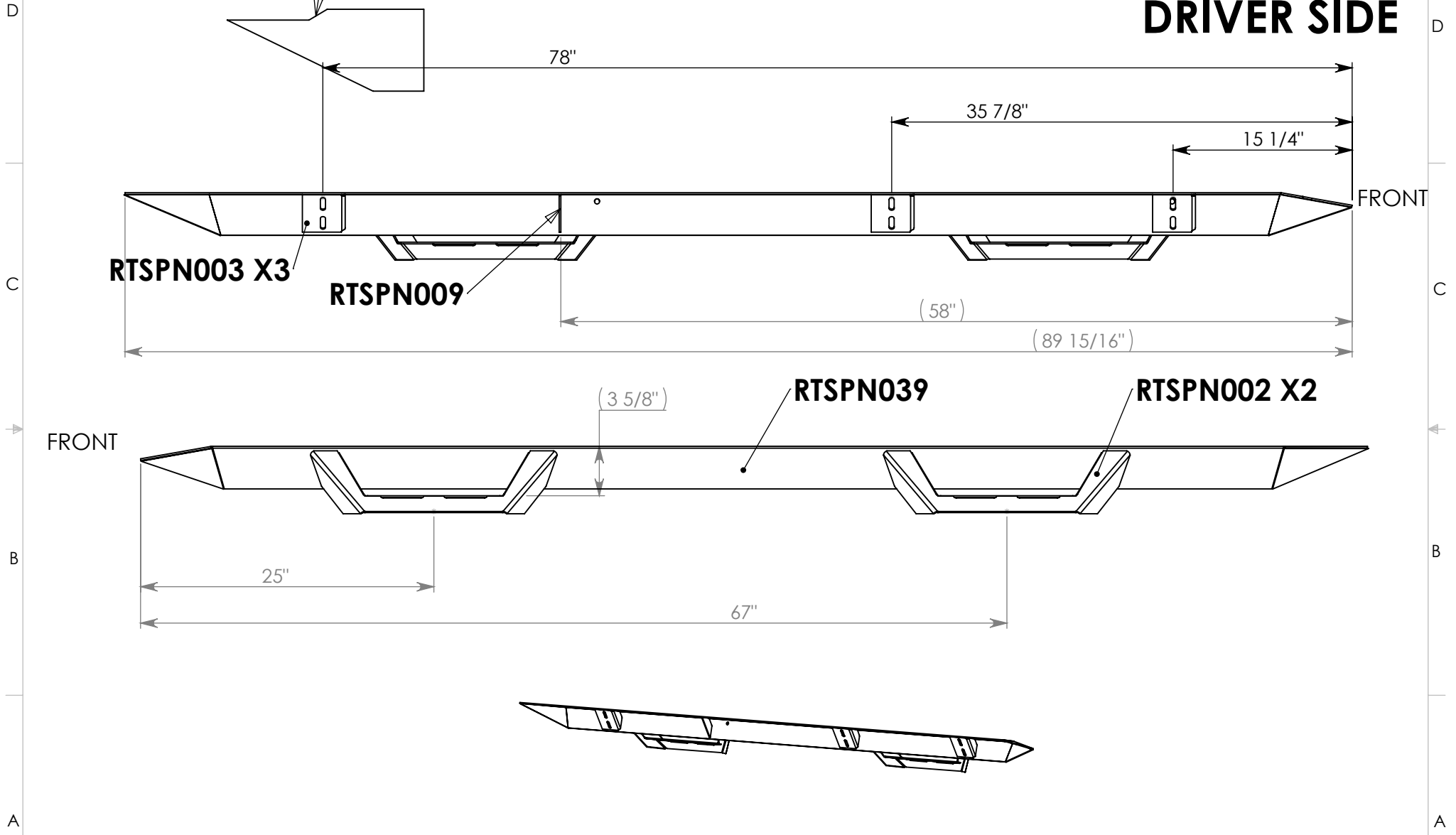

Part Number(s): RTS22FD - 2015 F150 CREW CAB RT STEP

Material(s): 1/8" STEEL SHEET MATERIAL

FILE:

Date:

Scale:

Drawing by:

RTSPN039

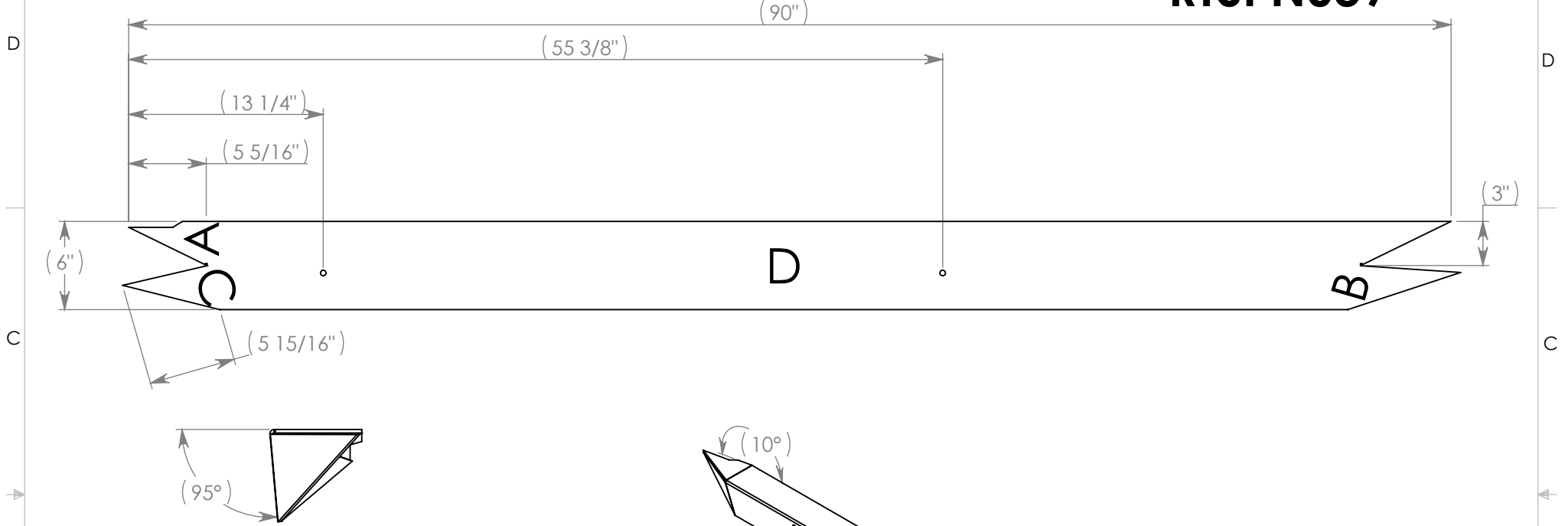

REVERSE BEND FOR PASSENGER SIDE

Tag	Direction	Angle	RS:
A	DOWN	10°	
B	DOWN	26°	
C	DOWN	26°	
D	DOWN	95°	

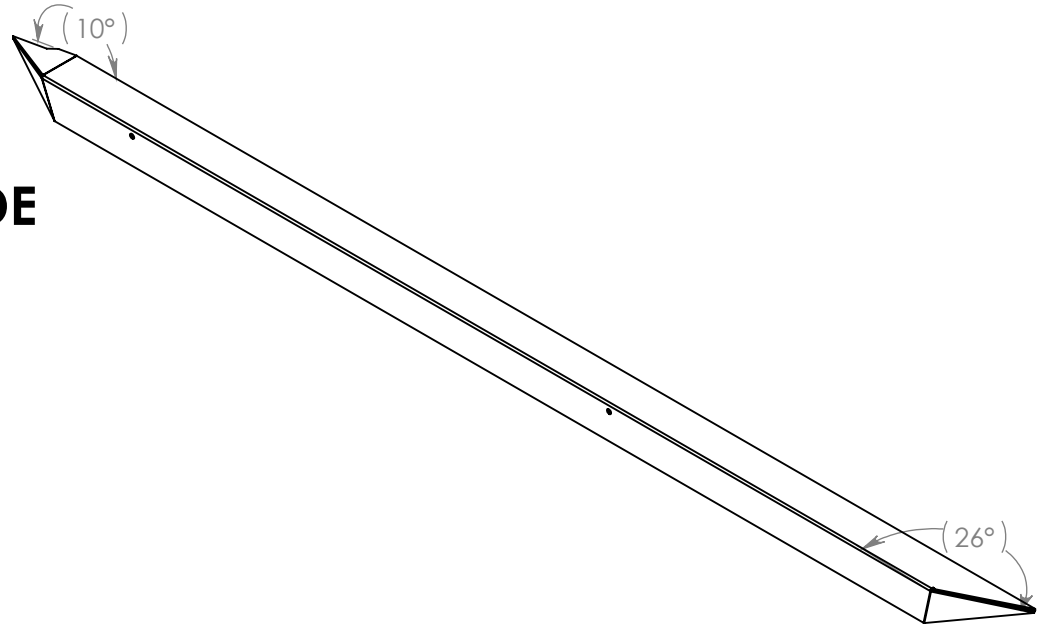

Part Number(s): RTSPN039 - MAIN BAR FOR RTS22FD

Material(s): 1/8" STEEL SHEET MATERIAL

FILE:

Date:

Scale:

Drawing by:

8 7 6 5 4 3 2 1

THE INFORMATION CONTAINED IN THIS DRAWING IS THE SOLE PROPERTY OF  ANY REPRODUCTION IN PART OR WHOLE WITHOUT THE WRITTEN PERMISSION OF  IS PROHIBITED.

RTSPN040 DRIVER SIDE

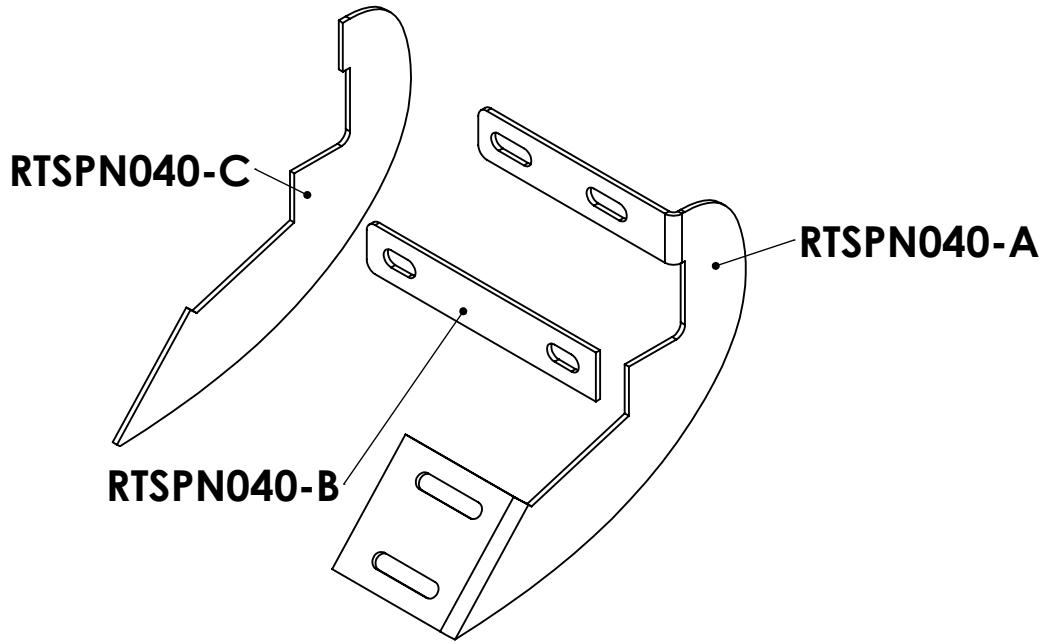

REVERSE FOR PASSENGER SIDE

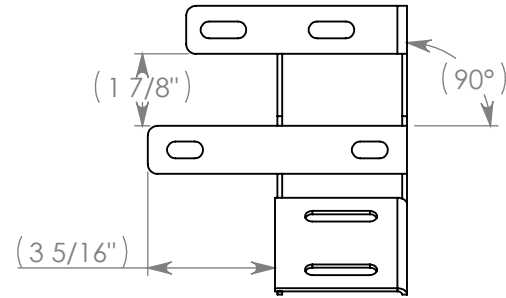
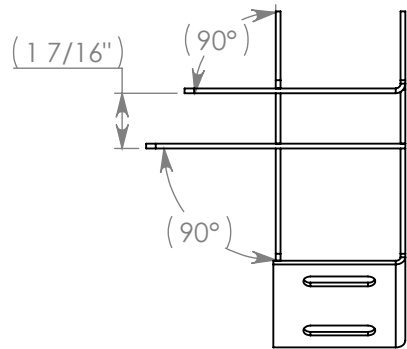

Part Number(s): RTSPN040 - OUTSIDE BRACKET FOR RTS22FD & RTS23FD

Material(s): 1/8" STEEL SHEET MATERIAL

FILE:

Date:

Scale:

Drawing by:

8 7 6 5 4 3 2 1

RTSPN040-A DRIVER SIDE

D

C

B

A

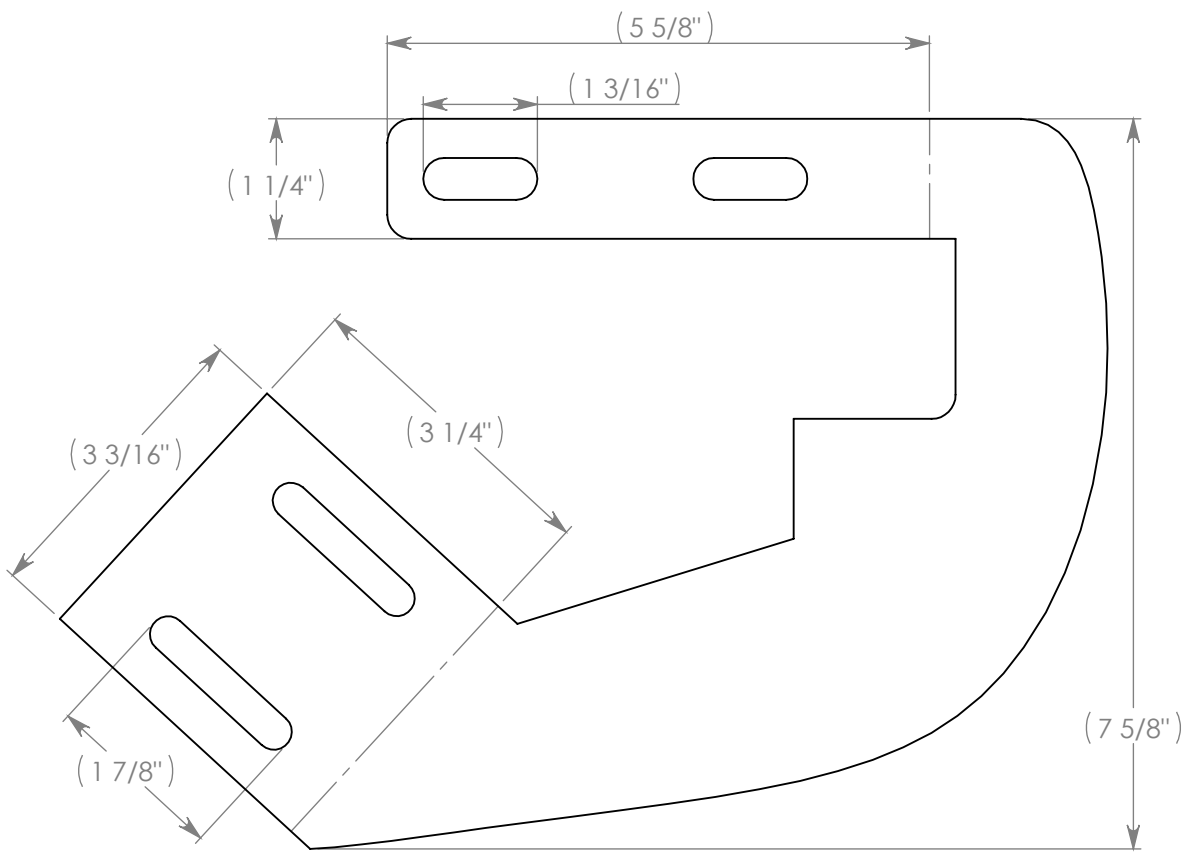

REVERSE FOR PASSENGER SIDE

(TRUE R1/4")

(TRUE R3/16")

D

C

B

A

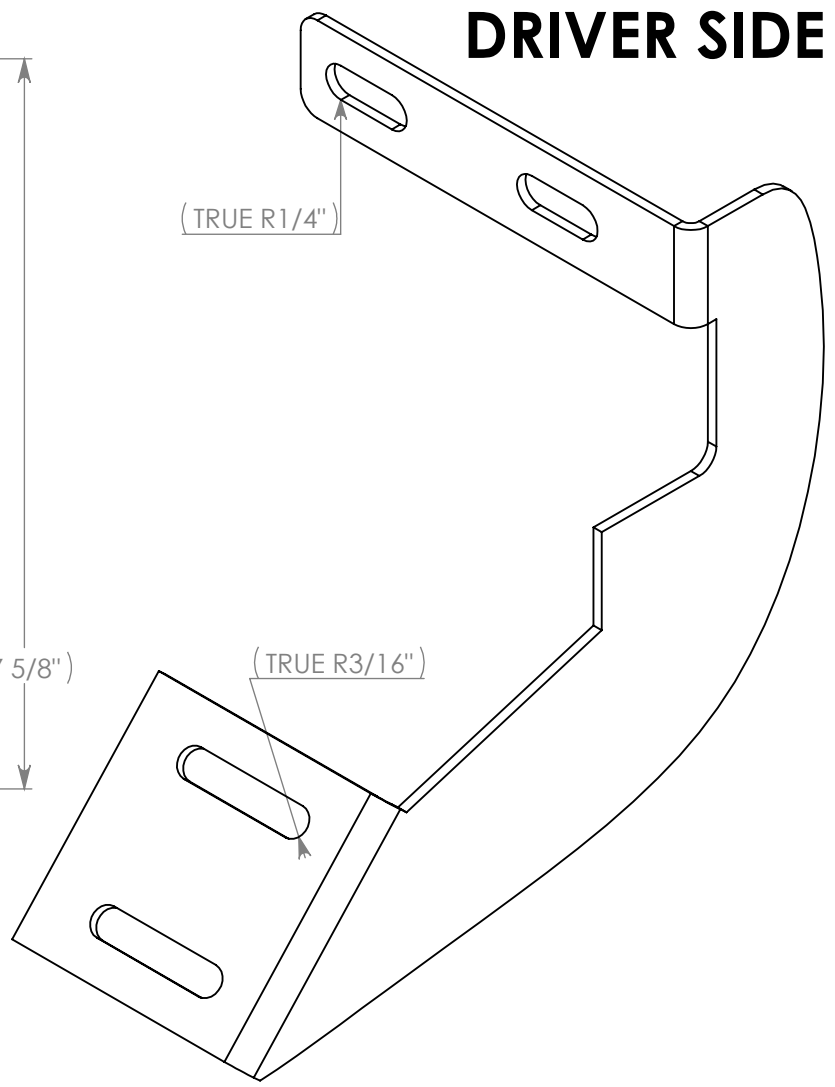

Tag	Direction	Angle	RS:
A	DOWN	90°	
B	DOWN	90°	



Part Number(s): RTSPN040-A - OUTSIDE BRACKET PART A FOR RTS22FD & RTS23FD

Material(s): 1/8" STEEL SHEET MATERIAL

FILE:

Date:

Scale:

Drawing by:

RTSPN040-B DRIVER & PASSENGER

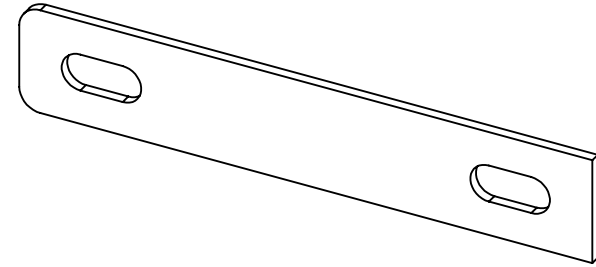
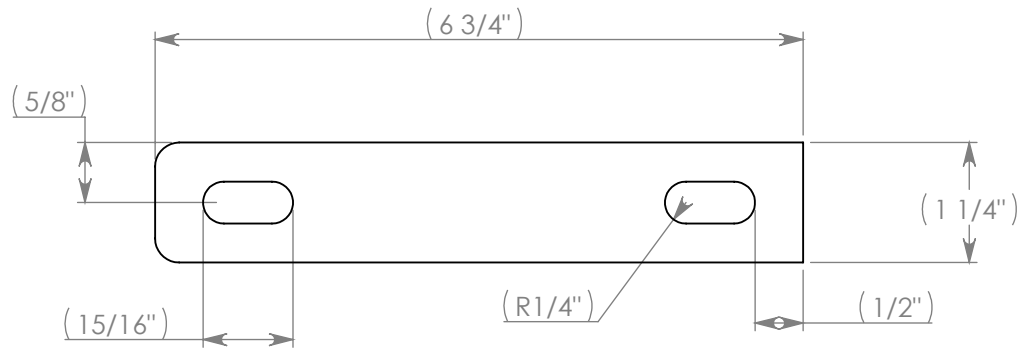

Part Number(s): RTSPN040-B - OUTSIDE BRACKET PART B FOR RTS22FD &RTS23FD

Material(s): 1/8" STEEL SHEET MATERIAL

FILE:

Date:

Scale:

Drawing by:

RTSPN040-C DRIVER & PASSENGER

D
C
B
A

D
C
B
A

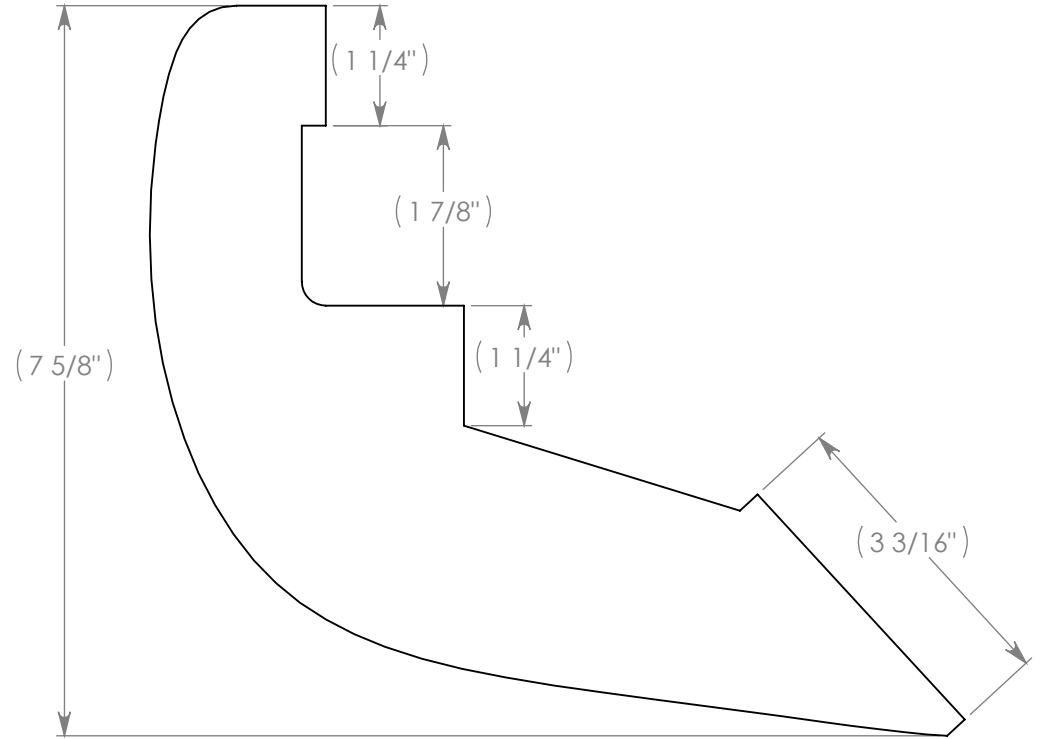
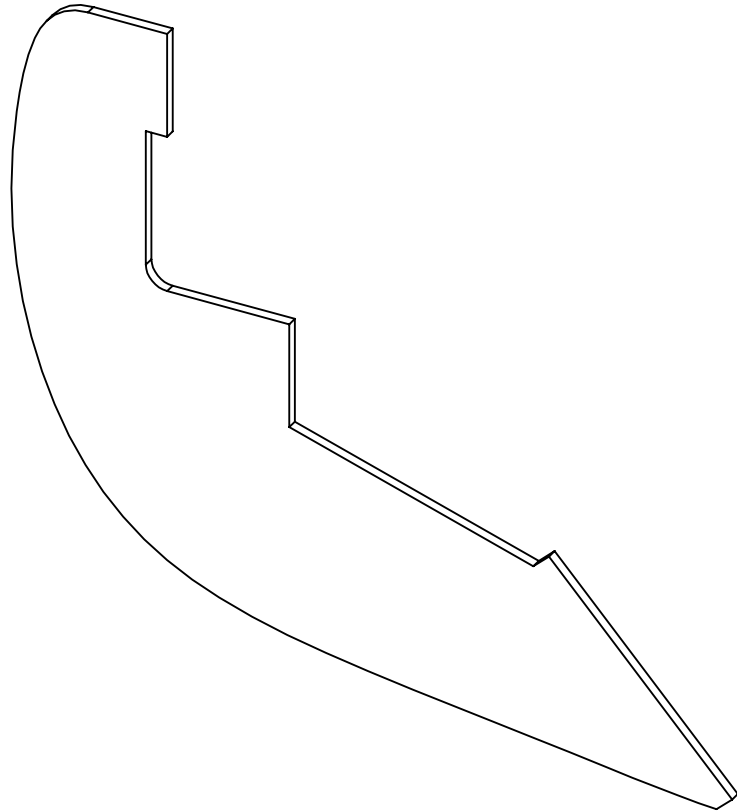

Part Number(s): RTSPN040-C - OUTSIDE BRACKET PART C FOR RTS22FD & RTS23FD

Material(s): 1/8" STEEL SHEET MATERIAL

FILE:

Date:

Scale:

Drawing by:

8 7 6 5 4 3 2 1