

RTS16CH

2014-2016 Chevrolet/GMC Crew Cab 1500 2015-16 Gas/Diesel HD Installation Instructions

Hardware Kit Includes Loose:

- (A) 32 – Hex head bolts (M8-1.25 x 30mm) Grade 8
- (B) 32 – Lock washers (M8) Grade 8
- (C) 56 – Flat washers (M8) Grade 8
- (D) 24 – Hex head nuts (M8-1.25) Grade 8
- (E) 8 – Long U-Nuts (M8-1.25)

Components List:

- (F) 2 – 1 Driver/1 Passenger RT Step
- (G) 1 – Passenger Front Mounting Bracket (DIESEL ONLY) RTSPN032
- (H) 8 – Mounting Brackets RTSPN033
- (I) 1 – 1/4" Spacer for RTSPN032 RTSPN035

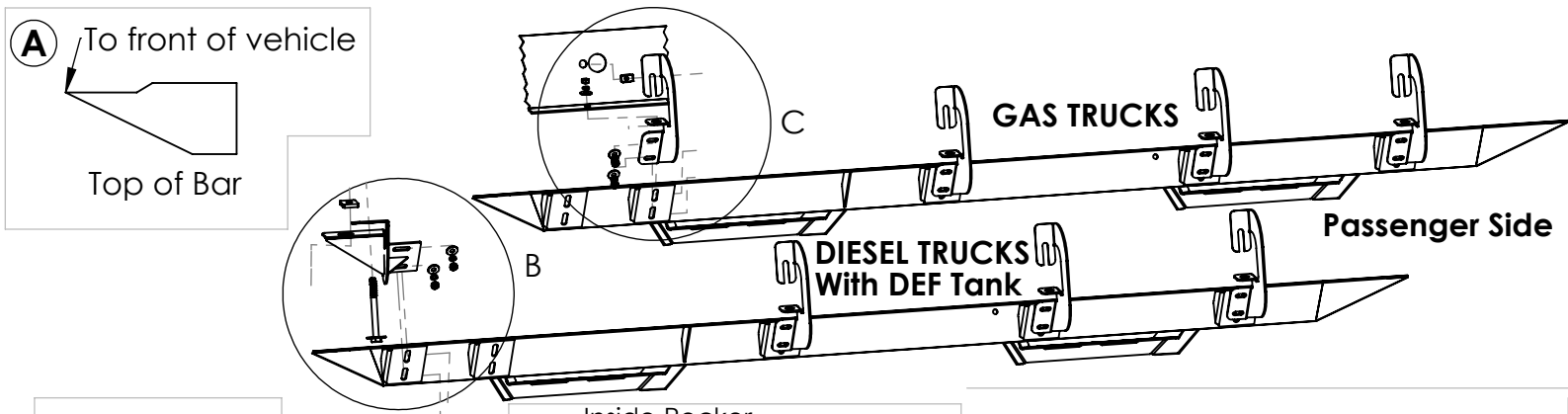

LOOSE FIT ALL COMPONENTS. DO NOT TIGHTEN UNTIL ALL COMPONENTS ARE INSTALLED AND ADJUSTED.

DISCLAIMER: USE ONLY COMPONENTS AND HARDWARE SUPPLIED BY ICI. NO SUBSTITUTIONS.

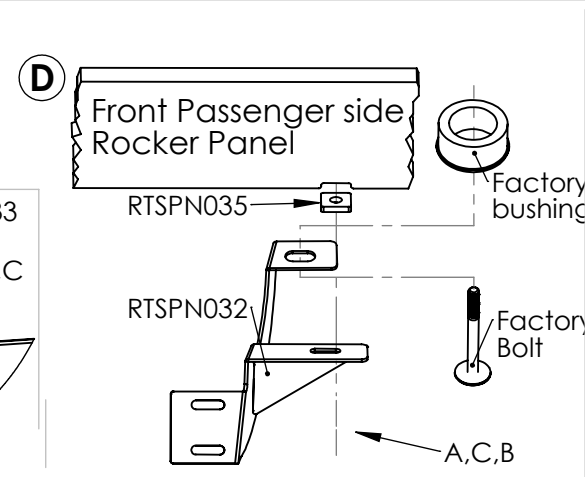
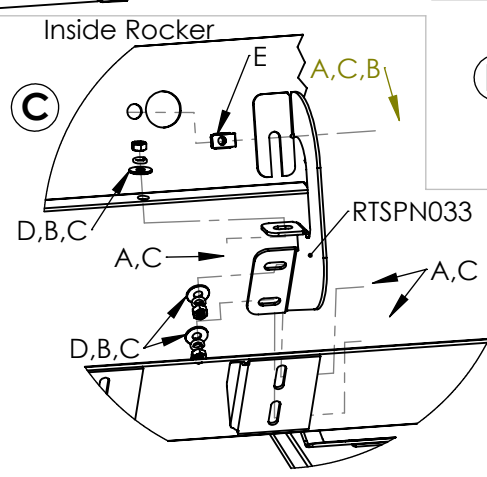
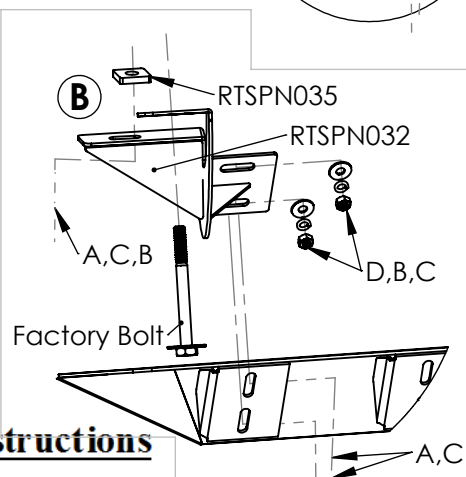

Step by Step Installation Instructions

- STEP 1:** Read and understand instructions completely before beginning installation. Remove all old steps and hardware from truck.
- STEP 2:** Locate the driver's side step (the notched end of the RT Step goes to the front of the vehicle). See (fig A).
- STEP 3:** The driver side step on gas and diesel trucks is mounted with (4) RTSPN033 brackets that bolt to the inside rocker panel and pinch weld area. Notice the orientation of the brackets, there are 4 driver side and 4 passenger sides. Some trucks may have threaded inserts in the inside rocker, if not use provided U-Nuts as shown in (fig C). Using provided 8mm bolt, two flat washers, lock washer and nut, bolt RTSPN033 to the pinch weld directly under where the threaded insert is or U-Nut is attached see FIG C. If you have either a gas or diesel without DEF tank, mount passenger side brackets the same as driver side and proceed to step 5, if you have a diesel with DEF tank proceed to step 4.
- STEP 4:** The front passenger side bracket on DEF diesel trucks use part RTSPN032, this bracket mounts to the front body mount and pinch weld/fender. Remove front body mount bolt and insert RTSPN032, keep the factory body mount bushing on top of RTSPN032 as shown in (fig D). Once RTSPN032 is attached to the body mount, the other mounting tab will line up with a factory threaded insert in the pinch weld, there may be a bolt in this insert. Remove factory bolt and line up RTSPN032. If RTSPN032 does not fit flush with the bottom of the pinch weld insert provided spacer (RTSPN035) and bolt RTSPN032 into place using provided hardware see (fig D). *GMC diesel trucks with factory fender, flare will need to be **LIGHTLY** trimmed for RTSPN032 to fit.
- STEP 5:** Once RT Step brackets are fitted, loose fit RT Step using provided hardware see (fig B & C). Once RT Step is loose fit, tighten brackets to inside rocker to 20 ft/lbs (**DO NOT USE IMPACT TOOLS**). Next, adjust bar up/down and front/back then tighten step to brackets at 30 ft/lbs.