

INSTALLATION GUIDE



SAFETY

THE SAFETY OF YOU AND OTHERS IS VERY IMPORTANT TO US!

In order to minimize this risk and make an informed decision about safety, it is important that you carefully read and follow the installation instructions we have provided.

We urge you to use your own good judgment and allow plenty of time for install.

HAZARD CHECKLIST

- Always wear personal protective equipment (PPE) such as: protective eye wear, gloves, close toed shoes, etc.
- We recommend that you use a certified mechanic or shop for professional installation.
- Always set emergency brakes on vehicle and use tire blocks to ensure vehicle stabilization.
- Use caution when lifting, we recommend the use of equipment to help lift bumpers into place.
- Use caution when using power tools such as air ratchet, etc.
- Take caution when installing wiring.
- Perform regular inspections of hardware, bolts, brackets, etc.
- Rigid light brackets are specifically designed to fit Rigid lights, we do not guarantee off brand fitment.
- Our winch mount is designed for Warn and Superwinch products. We do not guarantee off brand fitment.

USE & RISK

Bodyguard Products LLC is not responsible for damage to our products, or other subsequent damage that might occur, as a result of misuse or improper installation. While we do manufacture products that appear stronger than factory parts, our products should not be viewed or relied upon as life-saving devices in the event of a collision or rollover. We make no claims relating to airbag compatibility, crashworthiness, or sturdiness. It is the customer's responsibility to check with the vehicle manufacturer or auto dealer regarding airbag compatibility and automobile manufacturer's warranty before installing our products.

PREPARATION

- Ensure personal safety by checking for hazards and identifying risks.
- Check for correct hardware.
- Check for tools needed.
- Use either foam or tape on fenders to prevent scratches to the truck when installing your bumper.
- Please allow approximately 3-4 hours for installation.

TOOLS

- 1** - Jack
- 2** - Safety Stands
- 2** - Wheel Chocks
- 1** - Wire Cutters & Wire Crimpers
- 1** - Small Pry Tool
- 1** - Tape measure
- 1** - Pliers
- 1** - Metric Wrench/Sockets – 8mm, 10mm, 13mm, 14mm, 15mm, 18mm, 19mm, allen wrenches or sockets
- 1** - Level

BUMPER COMPONENTS

- 1** - Main Bumper Section
- 5** - Bumper Mesh
- 2** - Fog Light Buckets
- 2** - Parking Sensor Plates
- 2** - Bumper Wing End Caps
- 1** - Primary Skid Plate
- 1** - Secondary Skid Plate
- 1** - Adaptive Cruise Control Relocation Bracket (ACC)
- 1** - Camera Relocation Mount

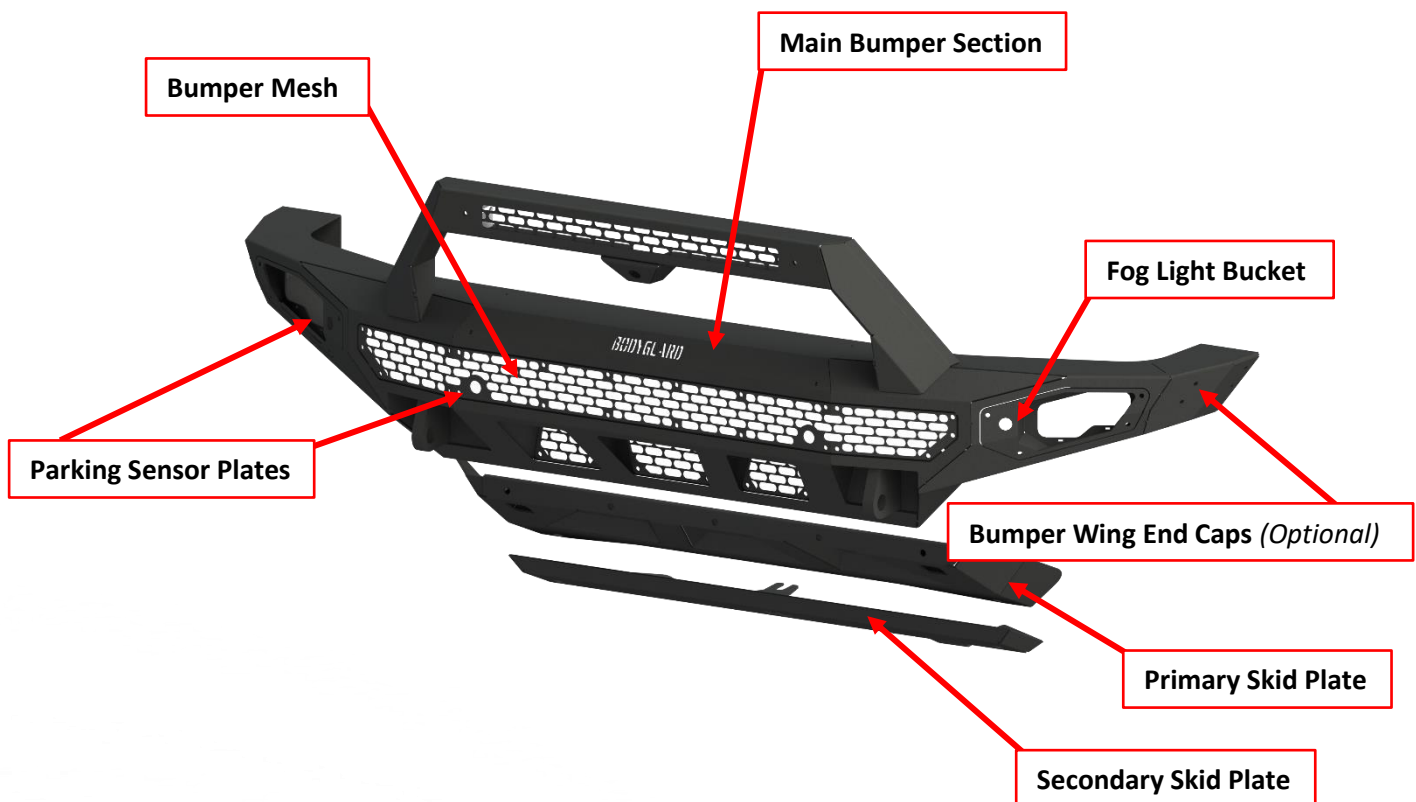

HARDWARE

Qty Parts

- 72**- 1/4" -20 x 3/4" Long, Stainless Steel SBHCS
- 30**- 1/4" -20 Stainless Steel SBHCS Grade 8 Serrated Hex Flange Nut
- 44**- 1/4-20 (.093-.126: Panel Range) Zinc Electroplate Spring Steel Cage Nut
- 20**- 5/16"-18 x 3/4" Long, Stainless Steel SBHCS
- 20**- 5/16"-18, Flange nut
- 25**- 5/16", Washer
- 8**- 5/16"-18 Clip Nut
- 6**- M12, WASHER
- 6**- M12-1.75 X 40MM, HB
- 4**- 21mm, Snap in, parking sensor plug, Black

BUMPER REMOVAL (HEAVY DUTY MODULAR)

1. Start by prying the (4) plastic clips holding the frame bolt covers with the pry tool. (Quantities may vary depending on trim level)

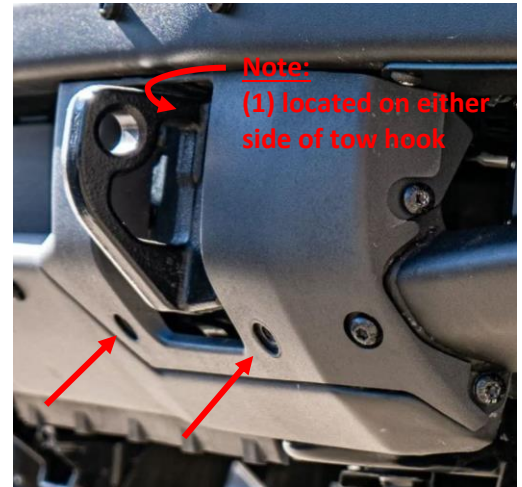

2. Once the plastic covers are removed, (a) locate the front sensor harness plug behind the driver side headlight and fender liner, (b) and unplug the harness. Now remove the 6 frame bolts using an 15mm socket, and the front bumper will come off.

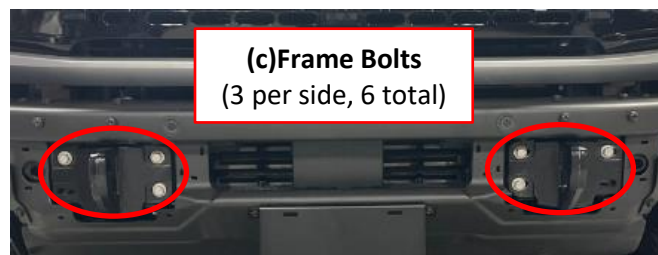
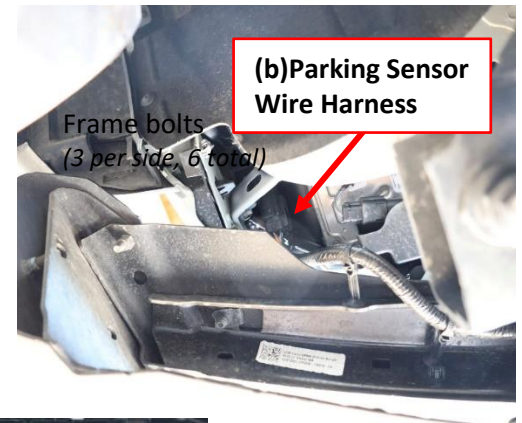

:::Once the bumper has been removed detach the parking sensor wire harness from the bumper:::

(d) Detach the wire harness from the bumper. Unclip the parking sensors from their mounts with the sensors attached.

- (8) 13mm bolts.
- (2) 8mm bolts.
- (19) Torx bolts.

Remove bumper structure plates and unclip the harness.



1. Once the bumper is off, locate the (6) bolts holding the skid plate, and remove the skid plate using the 15mm socket.



BUMPER REMOVAL (STANDARD)

1. Start by removing the fog light covers using the small pry tool and pry out. Then disconnect both parking sensors. (This should be done on the left and right side.)

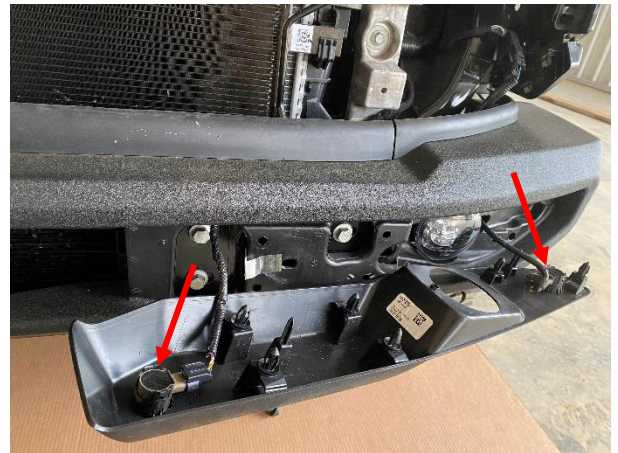

2. Once the plastic covers are removed, (a) locate the front sensor harness plug behind the driver side headlight and fender liner, (b) and unplug the harness. Now remove the 6 frame bolts using a 15mm socket, and the front bumper will come off.

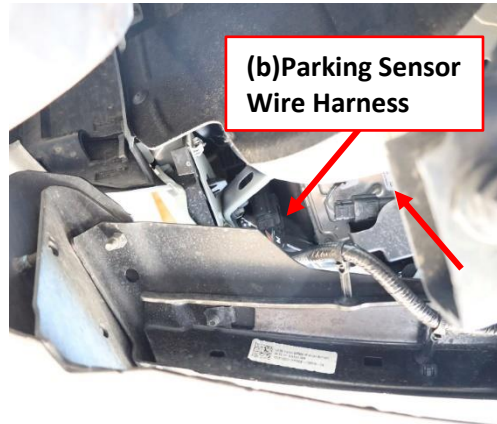

3. Once the bumper is off, detach the parking sensor wiring harness from the bumper, and locate the (6) bolts holding the skid plate, then remove the skid plate using the 15mm socket. With the skid plates off, remove both tow hook shrouds by sliding forward.

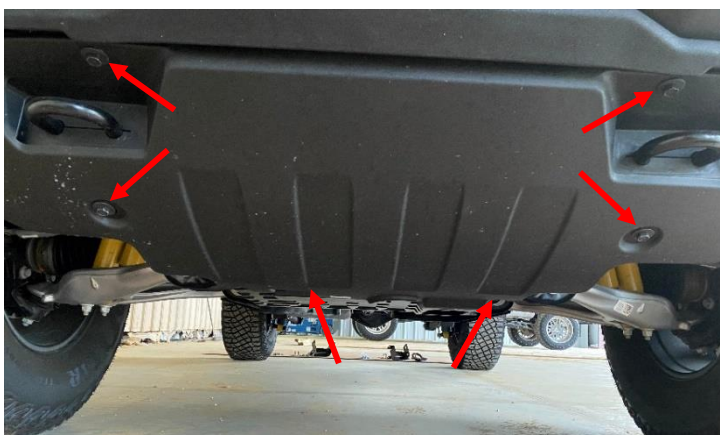

GRILL REMOVAL (For Camera Relocation)

(Skip this step if you do not have factory front camera)

1. Locate and remove the (9) clips holding the radiator cover to reveal the bolts holding the grill. Then remove the intake snorkel shown in the highlighted box to the right. Lift upwards to unclip and pull forwards. Once the intake snorkel is removed, remove the plastic radiator cover.

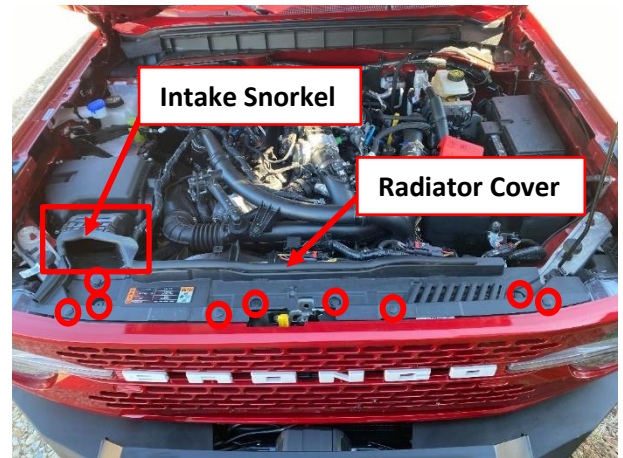

2. Once the radiator cover has been removed, remove the (4) bolts using a 10mm socket holding the top of the grill. Pry gently at the top corners of the grill and work your way around the bottom and pull outwards. Until the grill is free to be removed.



3. Now that the grill is free, disconnect your camera and camera washer spray line, above your passenger headlight. Once those items are disconnected, remove grill and set aside. Uninstall your camera from the grill and remove the factory camera harness and the sprayer tube. ***(Washer spray tubing will need to be capped or plugged: plug with a 1/4" bolt and zip tie)***

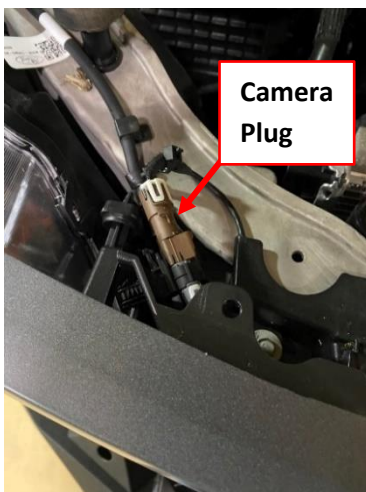

4. Reconnect the camera harness that you removed from the grill to the connector above your headlight. Run the harness down between the core support and your headlight. Attach the provided **89758 camera harness** to the factory harness. Once the Bodyguard bumper is installed the excess camera harness will run through the cutout in the baja bar up to the camera.



Camera harness routing.

ADAPTIVE CRUISE CONTROL RELOCATION BRACKET (*Optional*)

One ACC bracket included with all shipments:

Bracket # 80469

(fits behind factory grill)

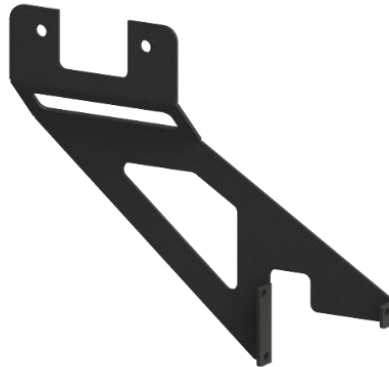

Bracket #80469
Fits behind factory
grill between hood
latch and core support

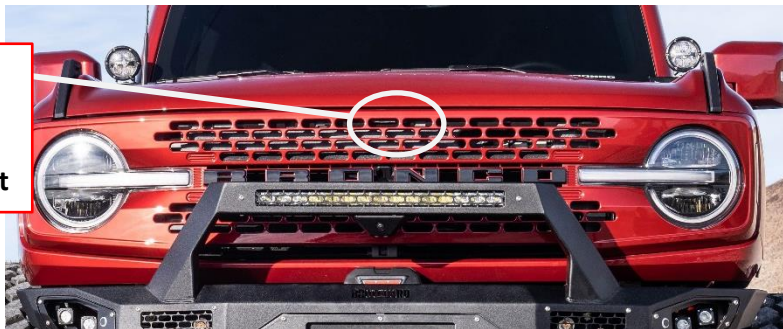

ADAPTIVE CRUISE CONTROL RELOCATION BRACKET (Optional)

1. Remove both driver and passenger fenders flares by twisting the quick release tabs. Once all tabs are rotated counterclockwise, firmly pull the fender outwards away from the vehicle to unclip.

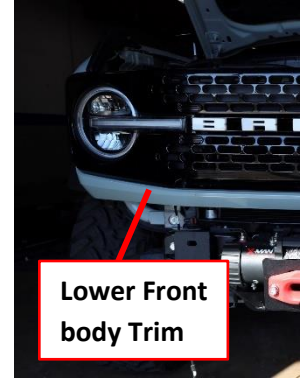

2. Remove the lower body trim by firmly pulling at the joint where it meets the fender. Once both sides have been disconnected from the fender, firmly pull from the center. This will reveal the screws required to fully remove both headlights. To remove the headlights, there are 2x 10mm screws on top, 1x 8mm at the bottom, and 1x Christmas Tree clip (per side). Once all screws and clips have been removed, gently pull on the headlight from the center of the vehicle to unseat from the clip. Then unplug the headlight from the factory harness. Repeat on the other side.

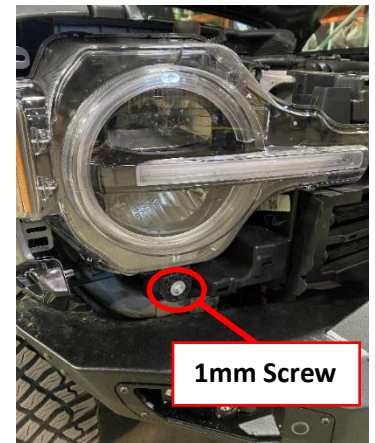

3. Remove the radiator shutters by removing 4x 10mm screws on top, and 4x 10mm screws on the front. Once screws are removed, unplug the harness connecting the shutters and remove.

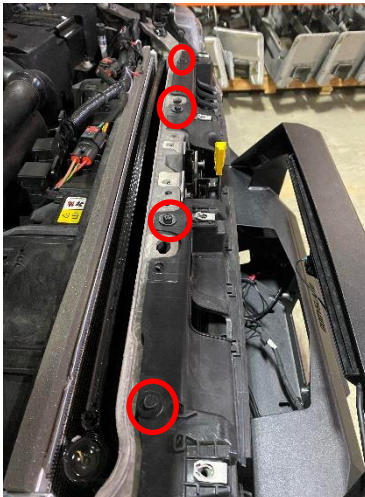

4. Remove the ACC module from the factory ACC bracket that is mounted to the radiator shutters and remove the rubber grommets on the ears of the ACC module. Install the ACC module to the ACC relocation mount using the provided spacers and 1/4-20 hardware. Then install the mount to the ACC relocation bracket (do not fully tighten).

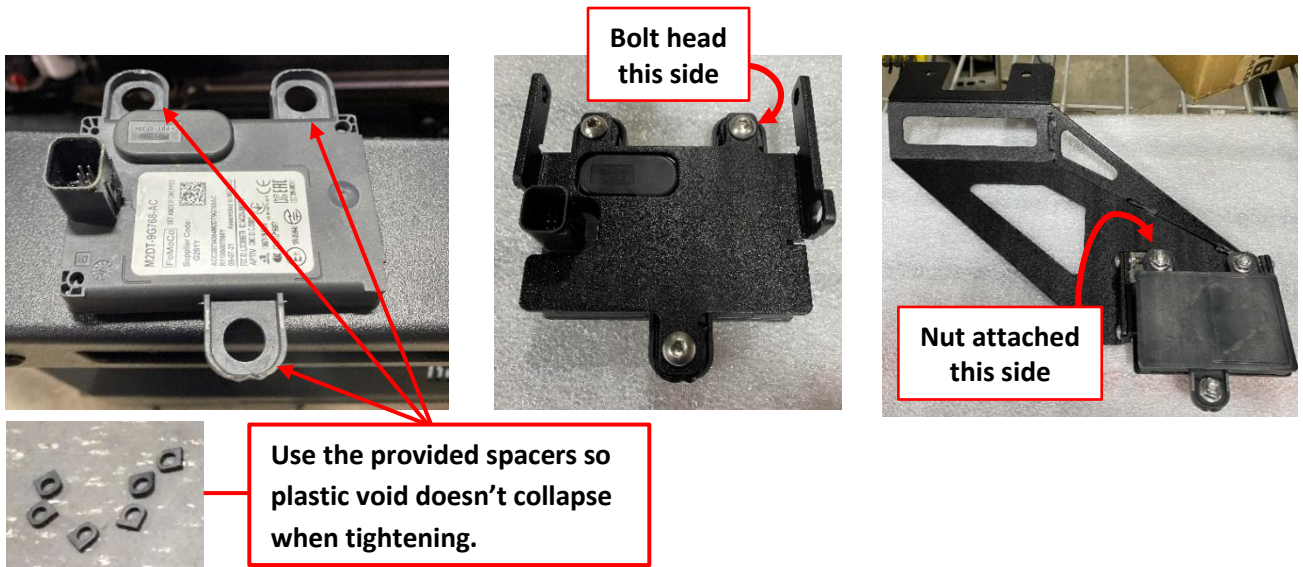

5. Remove the hood latch by removing 2x 10mm screws. Install the ACC relocation bracket in between the hood latch and the core support. Close the hood to make sure hood latch is in the proper position. Calibrate your ACC module by adjusting angle on the bracket. Place a level on the non-raised face of the ACC module. Once module is leveled, tighten all the hardware connecting the mount to the bracket. Plug in the ACC module (**you may need to unravel the acc cable from the harness to gain length to reach the module**). Reinstall all front-end components that were removed.

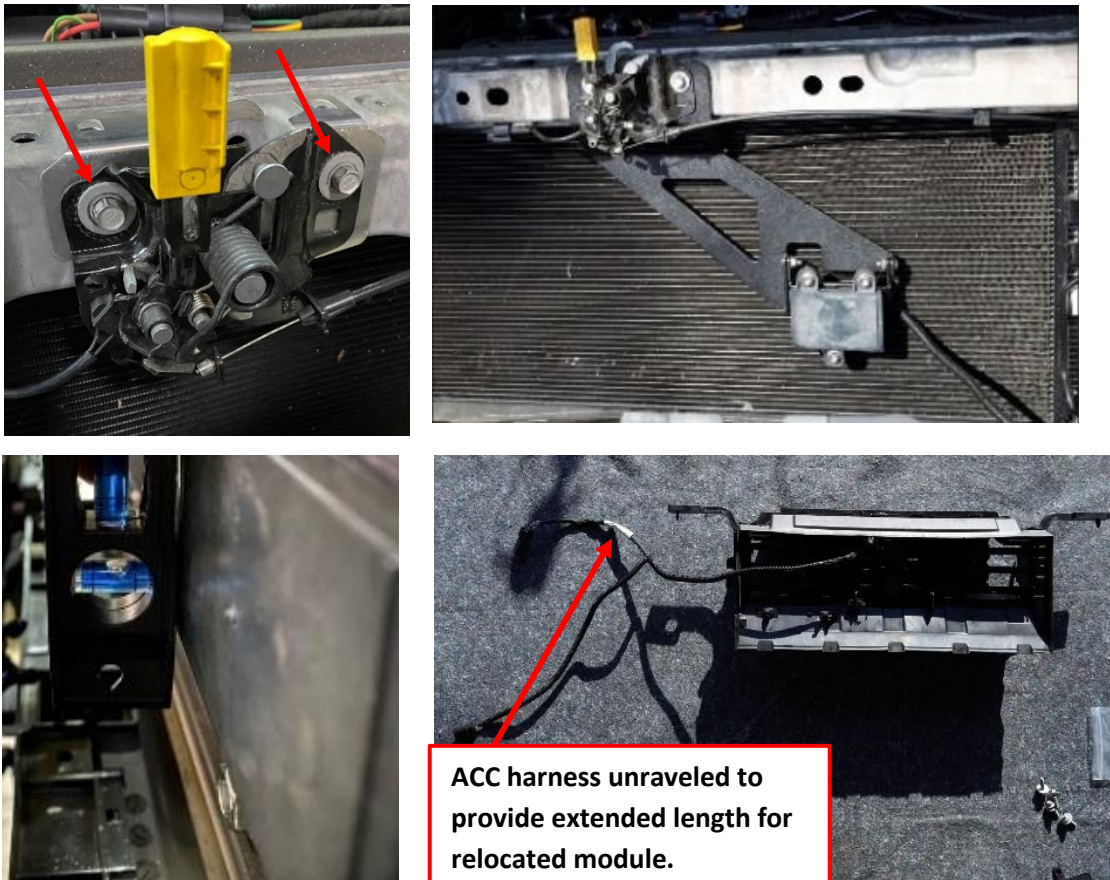

OPTIONAL END CAPS

1. From Hardware bag #2 install (4) 5/16" clip nuts on the wing end plates circled below. Then install the end caps to the bumper wing using the (4) 5/16" hardware. *(End caps are optional) If end caps are not used, install the 5/16" bolt and flange nut to plug the 4 holes.*

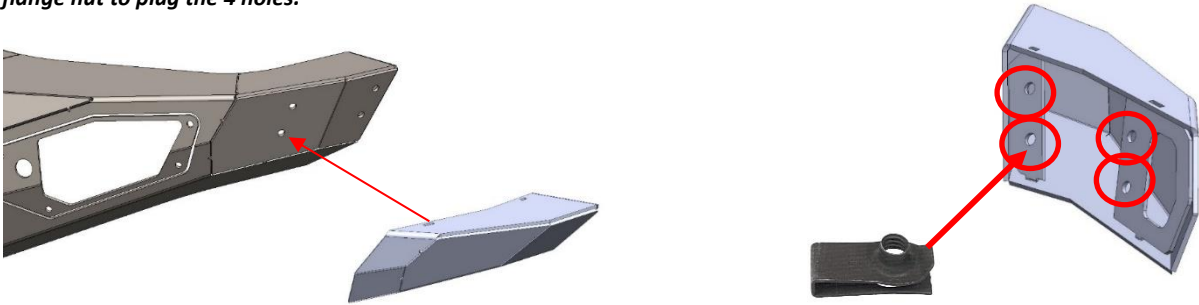

BUMPER INSTALL

1. Install 1/4"-20 cage nuts in all square holes on the bumper except the two circled areas shown below (*two per side*). You will install cage nuts on the fog light buckets in those areas. Cage nuts should be installed from the backside of the bumper.
2. Then carefully place the bumper up to the subframe using the 4x 1/2"-13 x 1-1/2" Long hardware.

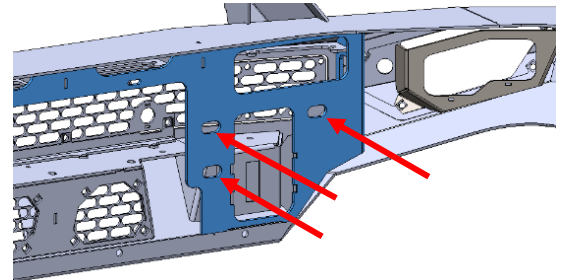
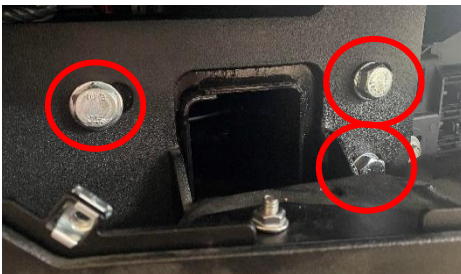
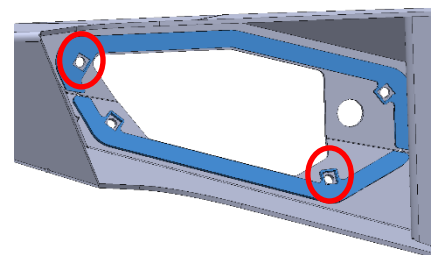

3. Adjust fitment vertically and horizontally, then tighten hardware.
4. Install 1/4"-20 cage nuts into the parking sensor plates. (Images below are example sensor plates). Then install the sensor tab over the sensor shown below. Slide the sensor and sensor tab into position and tighten down with a 1/4"-20 x 3/4" BHCS. Tighten screw finger tight. **Do not over tighten.** Set the plates and sensors aside.



Note: Do not over tighten sensors. If you choose to unplug the sensors from the harness, and the sensors are not working properly after installation, use CRC Dielectric grease PN#05113 on all sensors and main harness plug.

5. If your vehicle does not come equipped with parking sensors, install the provided plugs and install them into the parking sensor holes. Install fog light pods onto the fog light buckets, then install the fog light buckets onto the bumper along with the sensor plate for the fog lights. Be sure to plug in the sensor to the harness before installing.



Parking sensor

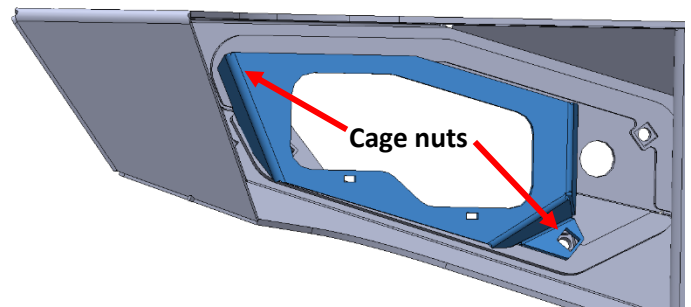

BAJA BAR CAMERA INSTALL

1. From hardware bag #1, install the camera pod to the baja bar using (2) 1/4"-20 cage nuts and (2) 1/4"-20 x 3/4" BHCS. Then install the camera into the pod and secure with the camera bracket using (2) 1/4"-20 BHCS and flange nuts.

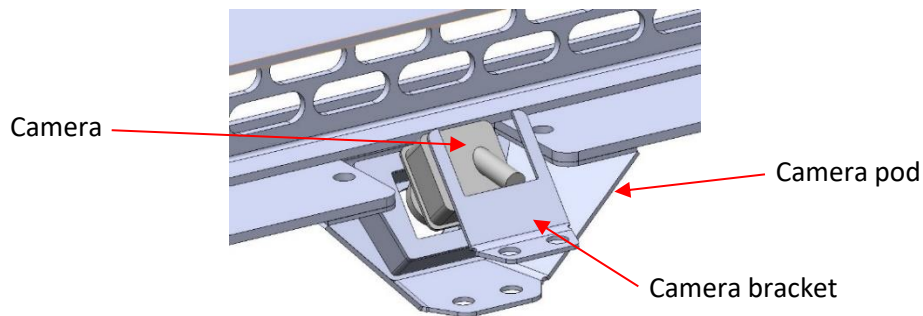

2. Then install the sport bar mesh using 2x 1/4"-20 x 3/4" BHCS and flange nuts. Then install your light bar using the light bar brackets if applicable.

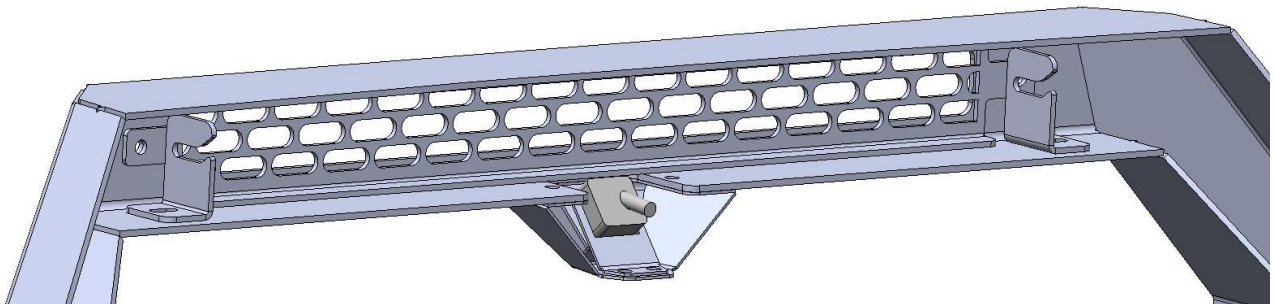

NOTE: If front license plate is required, optional front license plate bracket will need to be purchased with this bumper.

SKID PLATE INSTALL

6. Fasten the skid plate bracket to the bumper using 1/4"-20 BHCS, 1/4"-20 nut, and 5/16 washer.

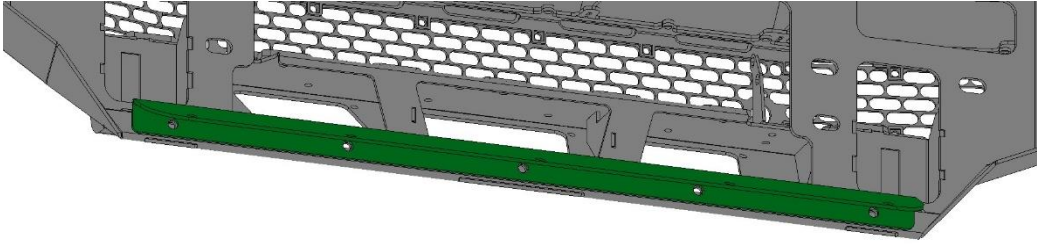

7. Install the 2x factory skid plate hardware loosely and slide the secondary skid plate onto the bolts. Let the skid plate hang and install the front of the primary skid plate to the bumper using the 5/16" hardware. Then install the primary and secondary skid plate using the remaining factory skid plate hardware.



8. Plug the sensors into the harness on the center mesh and install to the bumper. Then install the plates below the center mesh.

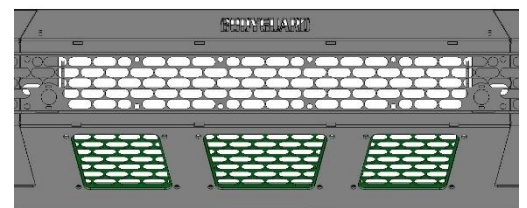

FINISHING UP

- Install shackles.
- Confirm that all hardware is tightened and everything is secure.
- Secure wiring harnesses for lights and sensors.
- Reconnect the battery.
- Test all lighting and wiring before using vehicle (fog lights, sensors, etc.).

MAINTENANCE

- Periodically check that all hardware is tightened and that all wiring and connections are secure.
- Periodically check that all sensor plugs are secure.
- Routinely wash bumper to maintain the powder coat finish.

FEEDBACK

We'd love to hear from you!

Please send your pictures, testimonials, comments, or suggestions to us by email at info@bodyguardbumpers.com. We frequently use customer pictures for brochures and marketing materials, and we always welcome customer feedback to ensure quality improvements within our company. Thanks for your purchase; we appreciate your business very much!

Where **STRENGTH** Meets *Style!*™



@BodyguardBumpers