

INSTALLATION GUIDE



SAFETY

THE SAFETY OF YOU AND OTHERS IS VERY IMPORTANT TO US!

In order to minimize this risk and make an informed decision about safety, it is important that you carefully read and follow the installation instructions we have provided.

We urge you to use your own good judgment and allow plenty of time for install.

HAZARD CHECKLIST

1. Always wear personal protective equipment (PPE) such as: protective eye wear, gloves, close toed shoes, etc.
2. We recommend that you use a certified mechanic or shop for professional installation.
3. Always set emergency brakes on vehicle and use tire blocks to ensure vehicle stabilization.
4. Use caution when lifting, we recommend the use of equipment to help lift bumpers into place.
5. Use caution when using power tools such as air ratchet, etc.
6. Take caution when installing wiring.
7. Perform regular inspections of hardware, bolts, brackets, etc.
8. Rigid light brackets are specifically designed to fit Rigid lights, we do not guarantee off brand fitment.
9. Our winch mount is designed for Warn and Superwinch products. We do not guarantee off brand fitment.

USE & RISK

Bodyguard Products LLC is not responsible for damage to our products, or other subsequent damage that might occur, as a result of misuse or improper installation. While we do manufacture products that appear stronger than factory parts, our products should not be viewed or relied upon as life-saving devices in the event of a collision or rollover. We make no claims relating to airbag compatibility, crashworthiness, or sturdiness. It is the customer's responsibility to check with the vehicle manufacturer or auto dealer regarding airbag compatibility and automobile manufacturer's warranty before installing our products.

PREPARATION

- Ensure personal safety by checking for hazards and identifying risks.
- Check for correct hardware.
- Check for tools needed.
- Use either foam or tape on fenders to prevent scratches to the truck when installing your bumper.
- Please allow approximately 3-4 hours for installation.
- Disconnect the battery.

TOOLS

- 1** - Jack
- 2** - Safety Stands
- 2** - Wheel Chocks
- 1** - Wire Cutters & Wire Crimpers
- 1** - Small Pry Tool
- 1** - Tape measure
- 1** - Pliers
- 1** - Metric Wrench/Sockets – 13mm, 16mm, 18mm, allen wrenches or sockets

BUMPER COMPONENTS

- 1** - Main Bumper Section
- 4** - Parking Sensor Plates
- 2** - Bumper Wing End Caps
- 5** - Bumper Step Plates

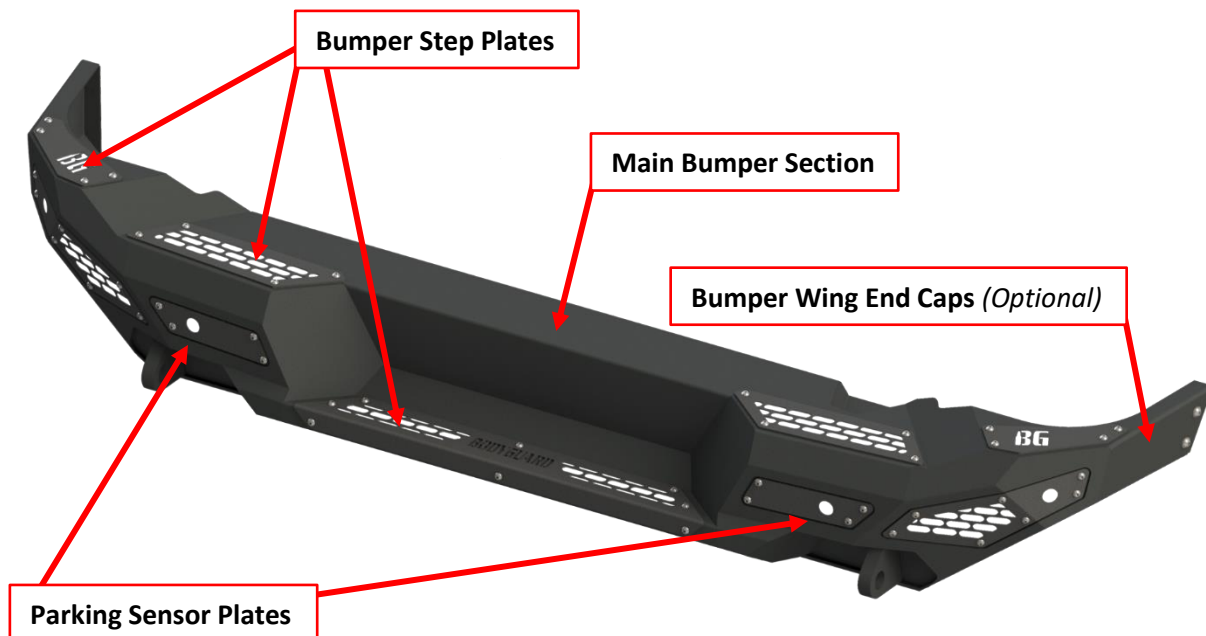

HARDWARE

Qty Parts

- 58**- 1/4" -20 x 3/4" Long, Stainless Steel SBHCS
- 58**- 1/4-20 (.093-.126: Panel Range) Zinc Electroplate Spring Steel Cage Nut
- 8**- 5/16"-18 x 3/4" Long, Stainless Steel SBHCS
- 8**- 5/16"-18, Flange nut
- 8**- 5/16", Washer
- 8**- 5/16"-18 Clip Nut
- 2**- 7/16"-14 x 1-1/4" Yellow Zinc Grade 8 Bolt
- 2**- 7/16 Washer, Grade 8 Zinc-Yellow
- 2**- 7/16-14 Grade 8 Steel Serrated Flange Nut Zinc
- 2**- Small Screw in license plate lights
- 2**- M12x1.5 Open Lug Nut
- 2**- M12x1.5 x 40mm, HB
- 1**- 8' Red and Black Wire
- 4**- 21mm, Snap in Plug Flush, Black

BUMPER REMOVAL

1. Locate the rear bumper wiring harness plugs on each side of the vehicle shown below. (Pictures shown with bumper removed for visibility.) The plugs are located on the rear side of the body mount towards the top of the bumper.

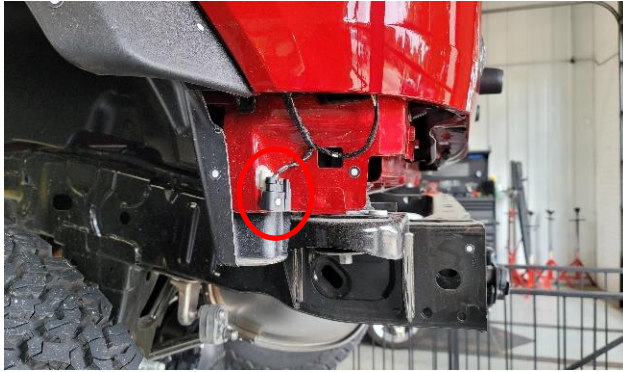

2. Locate the two 13mm bolts on the back side of the bumper attached to the frame tab and remove. (1 per side). Locate the two 18mm bolts (2 per side) under the bumper holding the hooks and bumper to the frame. These are the last bolts holding the bumper in place. Carefully remove the bumper.

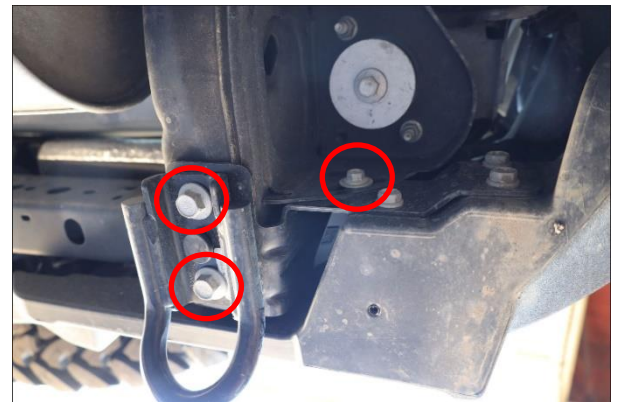

3. Remove the parking sensor harness and sensors that is routed through the factory bumper. The harness is routed through the bumper from the left to right side. Unclip the parking sensors from the mounts keeping the parking sensors connected to the harness. Unplug the license plate light plug. Using a pry tool unclip the harness from the bumper and remove. Set the harness and sensors aside for installation in the Bodyguard bumper.

BUMPER INSTALLATION

1. Install 1/4"-20 cage nuts in all of the square holes in the bumper. Then install all 5 of the step pad bolt in plates using the 1/4" - 20 x 3/4" Long BHCS allen bolts.

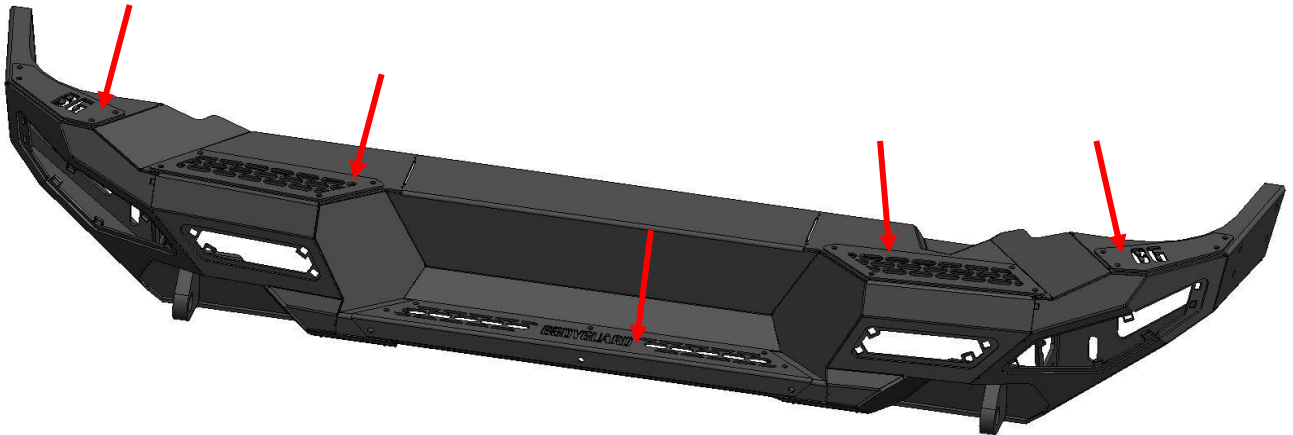

2. Then run your rear parking sensor wiring harness through the bumper to ensure that all sensor plugs can reach the respective openings. (Opening the wiring harness to gain more slack may be required.)

OPTIONAL END CAPS

1. Install (4) 5/16" clip nuts on the wing end plates circled below. Then install the end caps to the bumper wing using the (4) 5/16" hardware. (*End caps are optional*) **If end caps are not used, install the 5/16" bolt and flange nut to plug the 4 holes.**

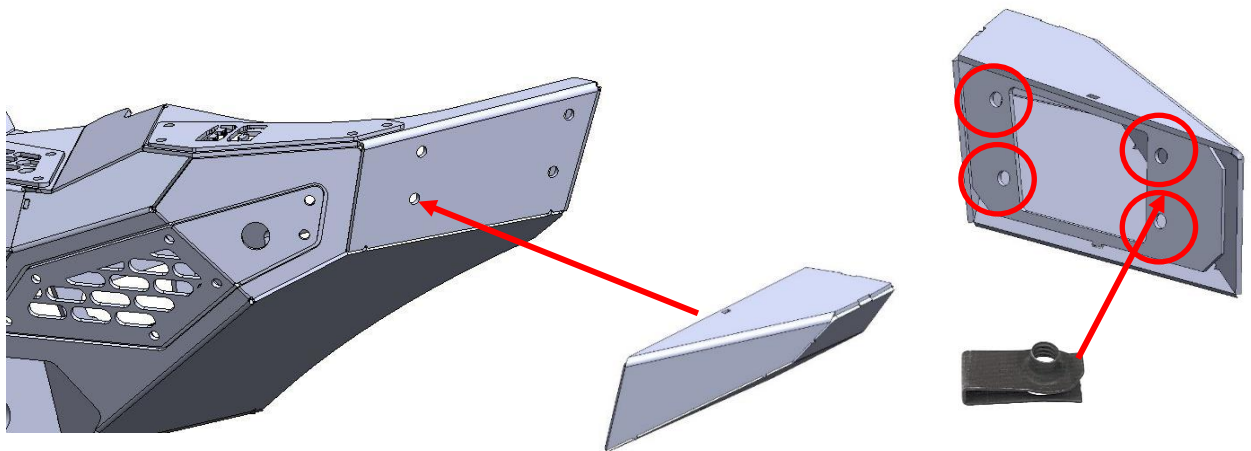

3. Carefully install the bumper and installing the 2 OEM bolts on the underside of the bumper (2 per side).



4. Install the provided 16mm 3/8" hardware (2 bolts, washers, and nuts) on the outer frame tab (1 per side). Now adjust the bumper fitment with the tape measure and tighten all bolts and hardware.



5. Now take all of your bolt in sensor plates and install the provided 1/4"-20 cage nuts. Then install your rear parking sensors onto the bolt in plates by placing the sensor tab over the sensor, then inserting them into the bolt in plate as shown below. Lastly secure the sensor by tightening 1/4"-20 x 3/4" long BHCS onto the sensor tab hand tight. **(Do not over tighten)**. If your vehicle does not come equipped with parking sensors, use the provided sensor plugs.

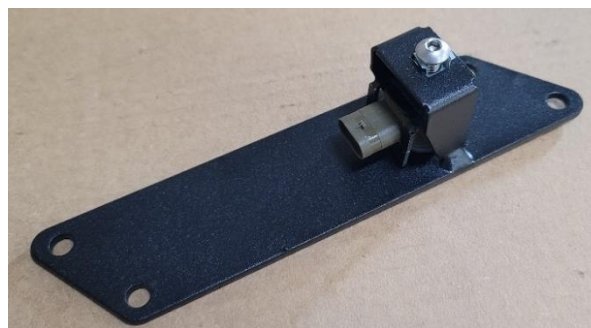

- At this time, if applicable, install your LED light pods to the bumper slots as shown below.

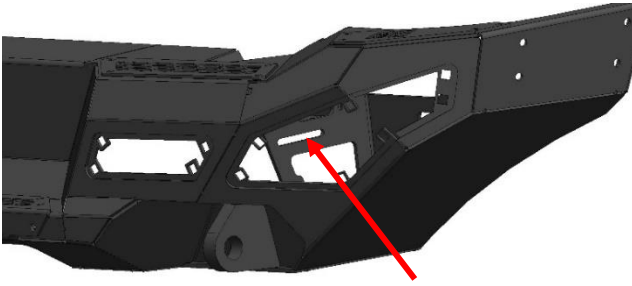

- Now plug all the sensors to the correct locations and install the bolt in plates using the 1/4"-20 X 3/4" long BHCS hardware provided.



LICENSE PLATE INSTALLATION

NOTE: The following section details installation of Bodyguard's **Spare Tire Delete** license plate install. If you are keeping your factory spare tire instead, we've included a bolt-on bracket to relocate the license plate from the bumper to the spare tire. The same wiring process will still apply whether you are using the license plate bracket or the Spare Tire Delete, as pictured below.

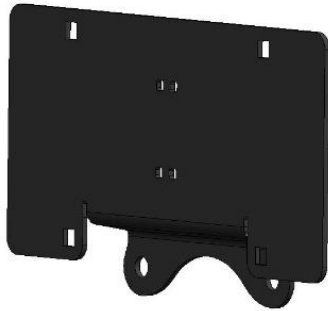

License Plate Bracket



Spare Tire Delete

SPARE TIRE DELETE INSTALLATION

1. Remove the spare tire and spare tire holder to access the wire harness in the door. Mount the spare tire delete using the provided hardware



2. Twist together the 2 red and 2 black wires from the license plate lights.
(NOTE: Images shown are using the Spare Tire Delete).



3. Take the two supplied Scotch Locks and provided wiring and connect them to the license plate lights.

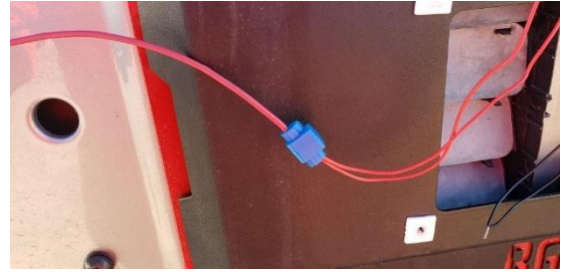

4. Next run the new wiring into the wiring harness from the factory spare tire carrier shown in the following image. You will need to cut the factory electrical tape and unravel the cloth tape. Be careful to not cut the wiring harness underneath. Run the new red and black wires inside the door attaching it to the existing wiring harness with tape or zip ties. You will have to pull the rear door accessory panel off by lightly prying at the bottom edges. Then peel back the cloth tape/electrical tape and run the red and black wire through the harness loom going from the rear door to the trunk

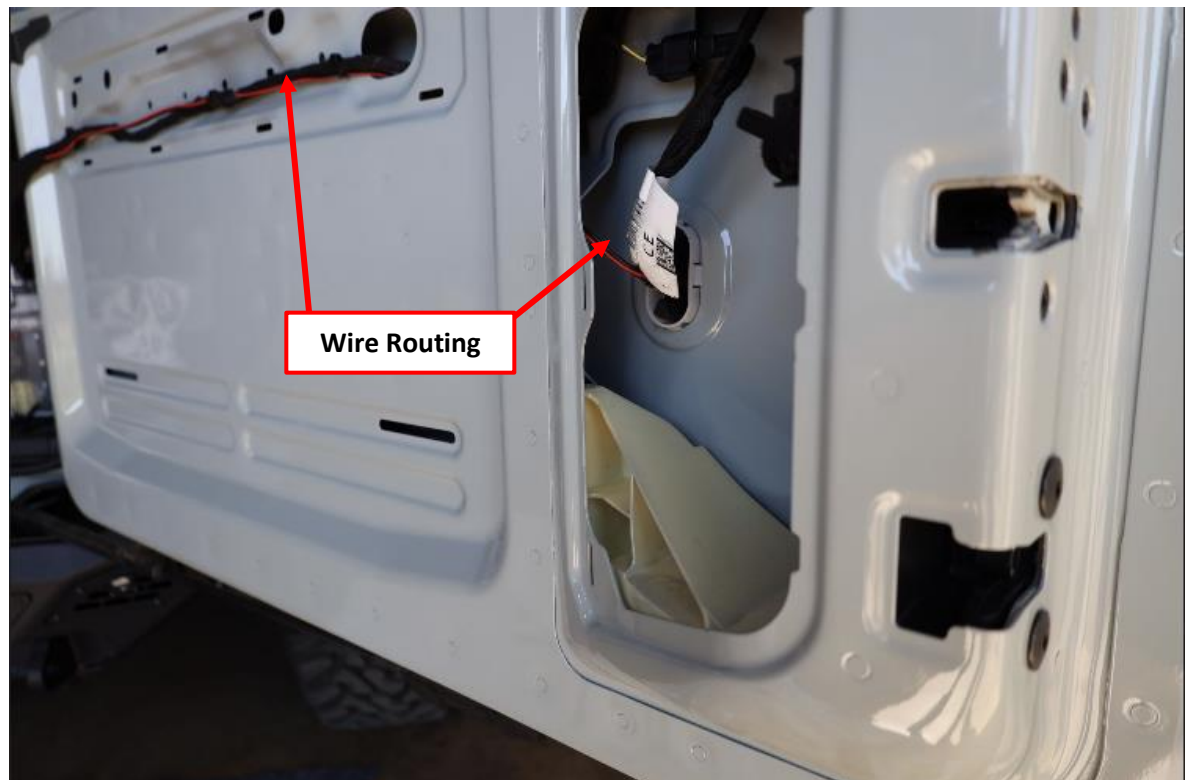

5. Connect the OEM wiring harness to the plugs that are attached to the door.



6. Run the new wiring down the side panel and under the weather bottom weather stripping to access the bumper wiring harness. You may need to remove the door molding for ease of access. Once the wiring has reached the bumper, cut the license plate light plug off that is attached to the parking sensor harness. splice wires into OEM tag light wires.

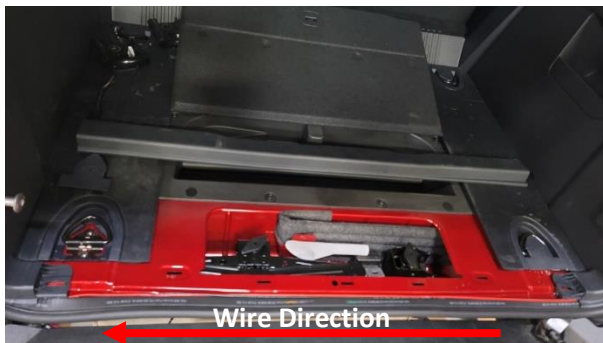

SPARE TIRE LICENSE PLATE MOUNT INSTALLATION

1. Replace the top two lug nuts holding the spare tire delete with the provided open ended threaded lug nuts.
2. Install the bracket using the 2x M12 bolts provided to the open ended threaded lug nuts.
3. Install the two (2) provided LED license plate lights through the license plate and the mounting bracket in the top holes. At this point it would be a good installation procedure to install male/female quick disconnect plugs on the red and black wire. In the event that the spare tire has to be removed, if the license plate wiring is hardwired, the red and black wires will have to be cut and reconnected. Quick disconnect provides a quick disassembly and reassembly of spare tire and license plate lights.

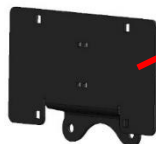

1. Remove the interior tailgate panels to access the wire harness in the door.



2. Take the two supplied Scotch Locks and provided wiring and connect them to the license plate lights.

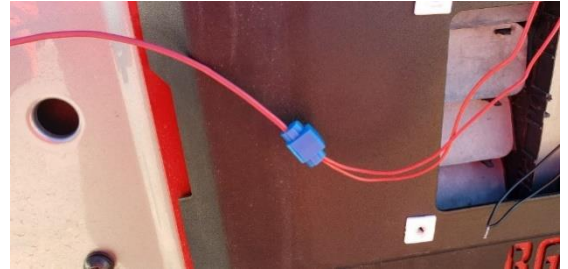

3. Next run the new wiring into the wiring harness from the factory spare tire carrier shown in the following image. You will need to cut the factory electrical tape and unravel the cloth tape. Be careful to not cut the wiring harness underneath. Run the new red and black wires inside the door attaching it to the existing wiring harness with tape or zip ties. You will have to pull the rear door accessory panel off by lightly prying at the bottom edges. Then peel back the cloth tape/electrical tape and run the red and black wire through the harness loom going from the rear door to the trunk

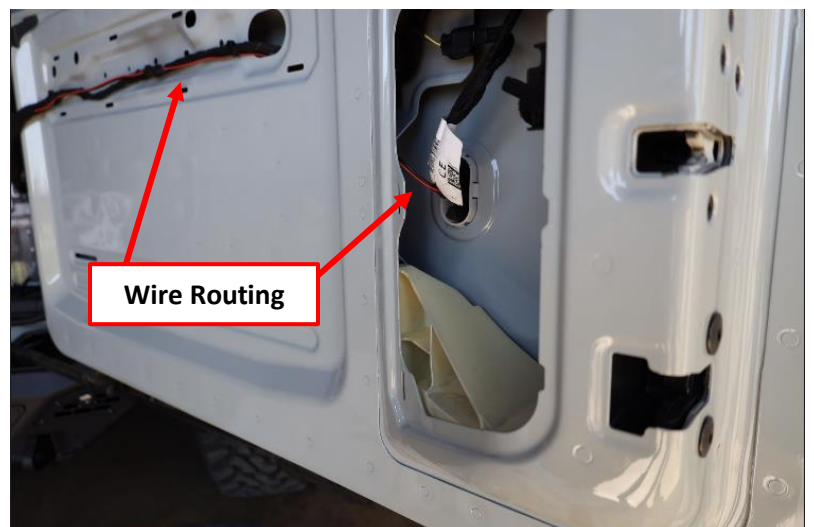

4. Connect the OEM wiring harness to the plugs that are attached to the door.



5. Run the new wiring down the side panel and under the weather bottom weather stripping to access the bumper wiring harness. You may need to remove the door molding for ease of access. Once the wiring has reached the bumper, cut the license plate light plug off that is attached to the parking sensor harness. splice wires into OEM tag light wires.



FINISHING UP

- Install shackles.
- Confirm that all hardware is tightened and everything is secure.
- Secure wiring harnesses for lights and sensors.
- Reconnect the battery.
- Test all lighting and wiring before using vehicle (fog lights, sensors, etc.).

MAINTENANCE

- Periodically check that all hardware is tightened and that all wiring and connections are secure.
- Periodically check that all sensor plugs are secure.
- Routinely wash bumper to maintain the powder coat finish.

FEEDBACK

We'd love to hear from you!

Please send your pictures, testimonials, comments, or suggestions to us by email at info@bodyguardbumpers.com. We frequently use customer pictures for brochures and marketing materials, and we always welcome customer feedback to ensure quality improvements within our company. Thanks for your purchase; we appreciate your business very much!

Where **STRENGTH** Meets *Style!*™



@BodyguardBumpers