

400 W. Artesia Blvd.
Compton, CA 90220
Fax: (310) 747-3912
Ph: 1-800-776-0767
E-Mail: info@procompusa.com
Website: www.procompusa.com

Latest Revision
Date:
8.19.2021



PRO COMP SUSPENSION

56714B/ BMX/ BP
K2078B/ BMX/ BP/ T/ M
2009-2012 Dodge 2500 6.7L Crew Cab 4X4 Long Arm
Lift kit

This document contains very important information that includes warranty information and instructions for resolving problems you may encounter. Please keep it in the vehicle as a permanent record.

Box 1 of 4 PN # 56714B-1

Part #	Description	Qty.	Illus.	Page
90-5337	DODGE NUT PLATE	2	6	10
90-5339	LOWER CONTROL ARM WASHER: 1/4"	2	8	11
90-2908	CRUSH SLEEVE: 7/8" X .120 Wall 1020 DOM	2	6	10
91-5340	CONTROL ARM BRACKET: Drvr	1	5,6,8	9,10,11
91-5351	CONTROL ARM BRACKET: Pass	1	5,6,8	9,10,11
91-2909	DODGE UPPER LONG ARM	2	8	11
91-2911	DODGE LOWER LONG ARM	2	8	11
90-4315	DODGE SWAY BAR DROP	2	11	13
90-6648	HARDWARE PACK: Upper Control Arms	2	-	-
15-11325	BUSHING	4	8	11
90-2871	SLEEVE	2	8	11
90-6679	HARDWARE PACK: Lower Control Arm	1	-	-
15-10980	BUSHING	8	8	11
90-2101	SLEEVE	4	8	11
90-3946	NUT PLATE: Control Arm Frame Bracket	2	6	10
90-6676	HARDWARE PACK: Control Arm Frame Bracket/Sway Bar	1	-	-
70-0501251800	1/2" X 1 1/4" HEX BOLT GR 8	10	6,7	10,11
72-050100816	1/2" STOVER NUT GR. C	6	6,7	10,11
73-05000042	1/2" HARDENED FLAT WASHER	16	6,7	10,11
70-0567001800	9/16" X 7" HEX BOLT GR 8	6	6	10
73-05600042	9/16" HARDENED FLAT WASHER	12	6	10
72-056100816	9/16" STOVER NUT GR. C	6	6	10
70-0624501800	5/8" X 4 1/2" HEX BOLT GR 8	2	8	11
72-062100816	5/8" STOVER NUT GR. C	2	8	11
73-06200042	5/8" HARDENED FLAT WASHER	4	8	11
72-043100810	7/16" HEX FINISH NUT GR 8	4	-	-
73-04300042	7/16" HARDENED FLAT WASHER	4	-	-
96-5364	CONTROL ARM BRACKET DRILL TEMPLATE: Drvr Front	1	7	11
96-5365	CONTROL ARM BRACKET DRILL TEMPLATE: Drvr Rear	1	7	11
96-5366	CONTROL ARM BRACKET DRILL TEMPLATE: Pass Front	1	7	11
96-5367	CONTROL ARM BRACKET DRILL TEMPLATE: Pass Rear	1	7	11
90-6748	HARDWARE PACK: Lower Control Arm: 2010 & Up Model	1	-	-
15-10978	BUSHING LOWER ARM	4	8	11
90-8083	SLEEVE	2	8	11

Box 2 of 4 PN # 56714B-2

DC601-1	PITMAN ARM	1	-	-
15-10995	BUMPSTOP	2	3	8
90-6029	HARDWARE PACK: Brake Line	1	-	-
15-10966	3/8" PLASTIC HOSE CLAMPS	4	-	-
13-20447	#10 X 1/2" HWH ZINC	4	-	-

Part #	Description	Qty.	Illus.	Page
90-6024	HARDWARE PACK: Sway Bar	1	-	-
70-0371501500	3/8" x 1 1/2" USS Gr. 5 Bolt	2	12	14
70-03725001500	3/8" x 2 1/2" USS Gr. 5 Bolt	2	12	14
72-03700100512	3/8" USS LOCKNUT	4	12	14
73-03700030	3/8" SAE FLAT WASHER	4	12	14
73-03700042	3/8" USS HARDENED FLAT WASHER	2	12	14
90-6312	HARDWARE PACK: Sway Bar Link	1	-	-
45359	HOURGLASS BUSHING	4	12	14
P-843	SPACER PACK	2	12	14
61150	3/8" SLEEVE	2	12	14
90-2039	SWAY BAR ADAPTER SLEEVE	2	12	14
90-1010	SWAY BAR END LINK	2	12	14
90-2357	DODGE SWAY BAR END LINK	2	12	14
13-90330	U-BOLTS: 9/16" X 3.65" X 13.5"	4	B	18
20-65302	HARDWARE PACK: U-Bolt	1	-	-
	9/16" WASHERS	8	B	18
	9/16" NUTS	8	B	18
95-300D	3" ALUMINUM BLOCK	2	B	17
51255	SHIM KIT	1	-	-
90-6327	HARDWARE PACK: Shim Kit	1	-	-
70-0432501800	7/16" X 2 1/2" HEX CAP SCREW GR. 8	2	-	-
73-04300830	7/16" SAE FLAT WASHER	4	-	-
72-043100816	7/16" STOVER NUT GR. C	2	-	-
90-3081	BUMP STOP BRACKETS	4	A	17
90-6223	HARDWARE PACK: Rear Bump Stop Bracket	1	-	-
70-0371251800	3/8-16 X 1 1/4" GRADE 8 HEX BOLT	4	A	17
72-037100816	3/8"-16 USS STOVER NUT	4	A	17
73-03700034	3/8" SAE GRADE 8 WASHER	8	A	17
90-6242	HARDWARE PACK: Sway Bar	1	-	-
600026	3/4" BUSHING	2	-	-
P-1036	SLEEVE	2	-	-
90-6430	HARDWARE PACK: Sway Bar	1	-	-
71-140802001000	14mm- 2.0 X 80mm HEX BOLT Gr. 10.9	2	-	-
.140CNUCZ	14mm- 2.0 STOVER NUT	2	-	-
73-01410930	14mm FLAT WASHER PLATED	4	-	-
13-90328	U-BOLTS: 5/8"-18- X 4.125" X 13.875"	4	B	18
20-65471	HARDWARE PACK: U-Bolt	1	-	-
	5/8" WASHERS	8	B	18
	5/8" NUTS	8	B	18
90-1539	FRONT BRAKE LINE EXTENSION BRACKET	2	-	-
90-6299	HARDWARE PACK: Front Brake Lines	1	-	-
70-0311001800	5/16" X 1" HEX BOLT GR. 8	2	-	-
72-0531100816	5/16" NYLOCK NUT	2	-	-
73-03100034	5/16" HARDENED FLAT WASHER	4	-	-

Part #	Description	Qty.	Illus.	Page
96-5779	PITMAN ARM TORQUE TOOL	1	9	12
HERNON427	RED THREAD LOCKER	1	-	-
Box 3 of 4 PN # 56716B-2				
91-7658	TRACK BAR DROP BRACKET	1	13	15
90-6874	HARDWARE PACK: Track Bar Drop Bracket	1	-	-
90-4460	TRACK BAR NUT	1	13	15
90-8233	CROSSMEMBER SLEEVE : 3/4" X 1 1/2"	1	13	15
90-8231	5/8" TRACK BAR DROP BOLT SPACER: Long	1	13	15
90-8232	5/8" TRACK BAR DROP BOLT SPACER: Short	1	13	15
61734	7/16" SPLIT- SLEEVE	1	13	15
90-7882	7/16" WASHER	2	13	15
HERNON427	THREAD LOCKER: RED	1	-	-
90-6852	HARDWARE PACK: Track bar Cam Bolt	1	-	-
90-4412	CAM BOLT	1	13	15
90-7663	CAM BOLT WASHER	1	13	15
73-06200838	5/8" GR. 8 AN FLAT WASHER PLATED	1	13	15
72-062200816	5/8"-18 SAE GR. 8 STOVER NUT	1	13	15
90-6875	HARDWARE PACK: Track Bar Drop Bracket	1	-	-
70-0624501800	5/8" X 4 1/2 HEX BOLTGR 8	1	13	15
72-062100816	5/8" STOVER NUT GR. C	1	13	15
73-06200034	5/8" HARDENED FLAT WASHER	2	13	15
70-0502501800	1/2" X 2 1/2" HEX BOLT GR 8	1	13	15
73-05000034	1/2" HARDENED FLAT WASHER	1	13	15
70-0433001800	7/16" X 3" HEX BOLT GR 8	1	13	15
72-043100816	7/16" STOVER NUT GR. C	1	13	15
73-04300034	7/16" HARDENED FLAT WASHER	1	13	15
Box 4 of 4 PN # 56714B-4				
929592	FRONT SHOCK	2	-	-
929543	REAR SHOCK	2	-	-
OR Box 4 of 4 PN # 56714BMX-4				
MX6158	FRONT SHOCK MX-6 SHOCK	2	-	-
MX6100	REAR SHOCK MX-6 SHOCK	2	-	-
OR Box 4 of 4 PN # 56708BP-3				
ZX2009	FRONT PRO RUNNER SHOCK	2	-	-
ZX2001	REAR PRO RUNNER SHOCK	2	-	-

OR Box 929592B/ 929543B (K2078T)

929592B	FRONT SHOCK	2	-	-
929543B	REAR SHOCK	2	-	-

OR PR2009/ PR2001 (K2078M)

PR2009	FRONT SHOCK	2	-	-
PR2001	REAR SHOCK	2	-	-

FOLLOWING PARTS ARE USED IN CONJUNCTION WITH THIS KIT. THEY ARE PACKAGED AND MUST BE ORDERED SEPARATELY.

**COIL SPRINGS: 56160 (Diesel)
or
COIL SPRINGS: 56170 (Gas)
AND
Transmission Bracket:
90-5152B Transmission Drop Bracket: 2007-2012 (6.7L Diesel) 1**

Optional Equipment Available from your Pro Comp Distribu-

56120 Double Shock Hoop Kit

Check out our outstanding selection of Pro Comp tires to compliment your new installation!

Tire and Wheel Information:

Tire and wheel choice is crucial in assuring proper fit, performance, and the safety of your Pro Comp equipped vehicle. For this application, a wheel not to exceed 10” in width with a minimum backspacing of 3 3/4” must be used. Additionally, a quality tire of radial design, not exceeding 37” tall X 13.5” wide is recommended. Violation of these recommendations will not be endorsed as acceptable by Pro Comp Suspension and will void any and all warranties either written or implied.

Introduction:

- ◆ This installation requires a professional mechanic!
- ◆ We recommend that you have access to a factory service manual for your vehicle to assist in the disassembly and reassembly of your vehicle. It contains a wealth of detailed information.
- ◆ Prior to installation, carefully inspect the vehicle's steering and driveline systems paying close attention to the tie rod ends, wheel bearing preload, pitman and idler arm. Additionally, check steering-to-frame and suspension-to-frame attaching points for stress cracks. The overall vehicle must be in excellent working condition. Repair or replace all worn or damaged parts!
- ◆ Read the instructions carefully and study the illustrations before attempting installation! You may save yourself a lot of extra work.
- ◆ Check the parts and hardware against the parts list to assure that your kit is complete. Separating parts according to the areas where they will be used and placing the hardware with the brackets before you begin will save installation time.
- ◆ Check the special equipment list and ensure the availability of these tools.
- ◆ Secure and properly block vehicle prior to beginning installation.
- ◆ **ALWAYS** wear safety glasses when using power tools or working under the vehicle!
- ◆ Use caution when cutting is required under the vehicle. The factory undercoating is flammable. Take appropriate precautions. Have a fire extinguisher close at hand.
- ◆ Foot pound torque readings are listed on the Torque Specifications chart at the end of the instructions. These are to be used unless specifically directed otherwise. Apply thread lock compound where specified.
- ◆ **Please note that while every effort is made to ensure that the installation of your Pro Comp lift kit is a positive experience, variations in construction and assembly in the vehicle manufacturing process will virtually ensure that some parts may seem difficult to install. Additionally, the current trend in manufacturing of vehicles results in a frame that is highly flexible and may shift slightly on disassembly prior to installation. The use of pry bars and tapered punches for alignment is considered normal and usually does not indicate a faulty product. However, if you are uncertain about some aspect of the installation process, please feel free to call our tech support department at the number listed on the cover page. We do not recommend that you modify the Pro Comp parts in any way as this will void any warranty expressed or implied by the Pro Comp Suspension company.**
- ◆ Disconnect the negative battery cable when working on the vehicle.

⇒ Front end and head light realignment is necessary!

⇒ Speedometer and ABS recalibration will be necessary if larger tires (10% more than stock diameter) are installed.

SPECIAL TOOLS

⇒ PLEASE REFER TO YOUR SERVICE MANUAL FOR MORE INFORMATION.

⇒ A SPECIAL REMOVAL TOOL IS REQUIRED FOR SAFE REMOVAL OF THE TIE RODS.

⇒ A SPECIAL REMOVAL TOOL IS REQUIRED FOR SAFE REMOVAL OF THE COIL SPRINGS.

⇒ THESE TOOL MAY BE PURCHASED AT YOUR LOCAL DEALER.

⇒ YOU MAY BE ABLE TO RENT ANY OF THESE TOOLS AT YOUR LOCAL PARTS STORE.

Front Installation

1. Prior to installing this kit. With the vehicle on the ground, measure the height of your vehicle. This measurement can be recorded from the center of the wheel, straight up to the top of the inner fender lip. Record the measurements below.

LF: _____ RF: _____

LR: _____ RR: _____

2. Ensure that your work space is of adequate size and the work surface is level. Set the emergency brake. Place your floor jack under the front axle and raise vehicle. Place jack stands under the frame rails behind the front wheel wells and lower the frame onto the stands. Remove the jack and place blocks both in front of and behind the rear wheels. Remove the wheels.
3. Remove any skid plates or debris shields from the bottom of the vehicle.
4. Unbolt both brake line brackets from the frame and front axle brackets to allow for free movement of the suspension components.
5. Unbolt the sway bar frame mounts from the frame.
6. Unbolt the sway bar from the end links and remove it from the vehicle. Save the sway bar and hardware for reinstallation.

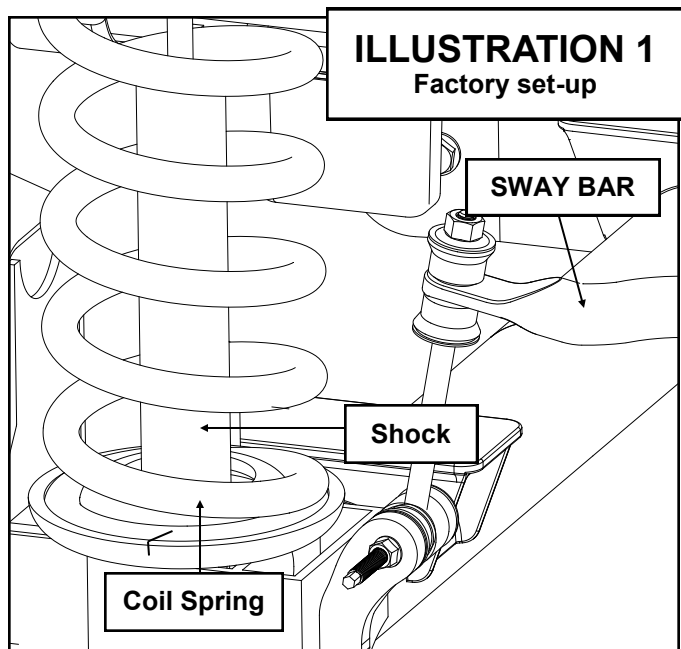

Work on one side of the vehicle at a time.

7. Raise a jack under the coil springs to support the axle.
8. With the front axle supported with a jack, disconnect and remove track bar. Lower the front axle. Save the hardware for reuse.
9. Locate the top shock mount in the engine compartment. Remove the nut, retainer and grommet from the shock. See ILLUSTRATION 2.
10. Remove the three **OE** nuts from the upper shock bracket. Remove the bracket and set aside.
11. Unbolt the shock absorber from the lower mount bracket on the axle. Remove the shock through the engine compartment.
12. Carefully lower the floor jack until the coil spring is free from the upper spring pocket. Remove the coil spring.
13. Remove and set aside the upper rubber isolation pad on the coil and the stud ring from the spring pocket. Save both parts for reinstallation.
14. Repeat on other side of the vehicle.
15. Locate the front rubber bump stops, mounted on the frame near the coils. Remove the bump stop from it's pocket using a pair of pliers. A back and forth action will assist in working it out.
16. Place the new bump stops, (**15-10995**), in existing bump stop pockets, as shown in ILLUSTRATION 3. By using leverage against the bottom of the bump stops, force the bump stop into place (detergent soap may help if the fit is tight).
17. Remove the **10mm OE** body mount nuts from the body mount studs closest to the upper arm frame mounting pockets. Save the hardware for reinstallation.
18. Starting on the driver side, Mark the location

Complete control arm removal and replacement on one side of the vehicle before removing the control arm from the other side.

of the index mark on the lower control arm adjustment cam-bolt and bracket, remove the

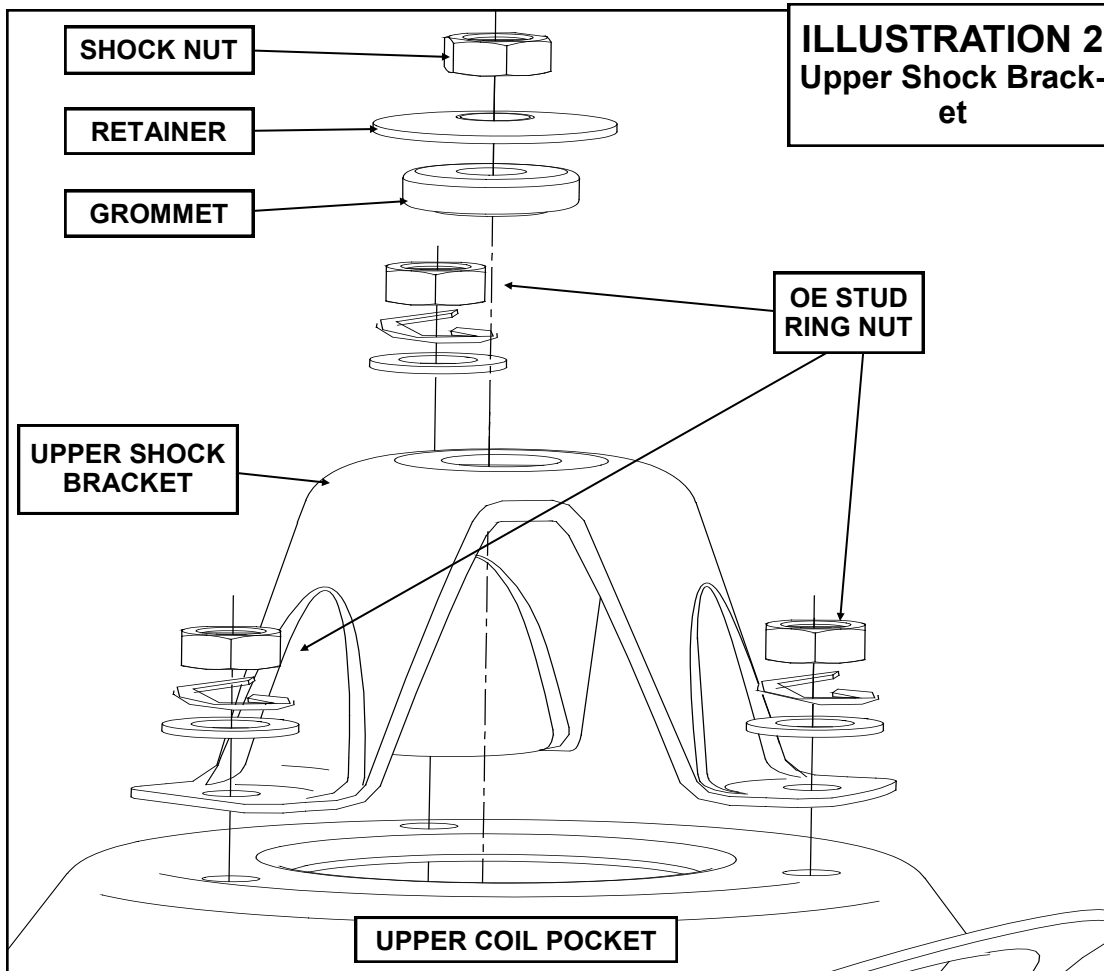

cam-bolt, washer and nut.

19. Next, remove the hardware from the frame bracket holding the lower control arm in place. Remove the control arm at this time.
20. Remove the factory upper control arm existing hardware from the axle bracket and frame bracket.
NOTE: On V8 and diesel models the exhaust may need to be removed on the driver and passenger side. If so, remove exhaust hanger bushings. Undo clamp on the turbo or unbolt from the header. Move exhaust out of the way to get the control arm bolt in and out. Remember to reinstall the exhaust to factory specifications.
NOTE: Some installers choose to cut the head off the passenger side upper control arm bolt rather than remove the exhaust. If you choose this method use the replacement bolt from pack (90-6654).
21. Support the transmission crossmember and remove the driver side OE crossmember bolts. Save for reinstallation.

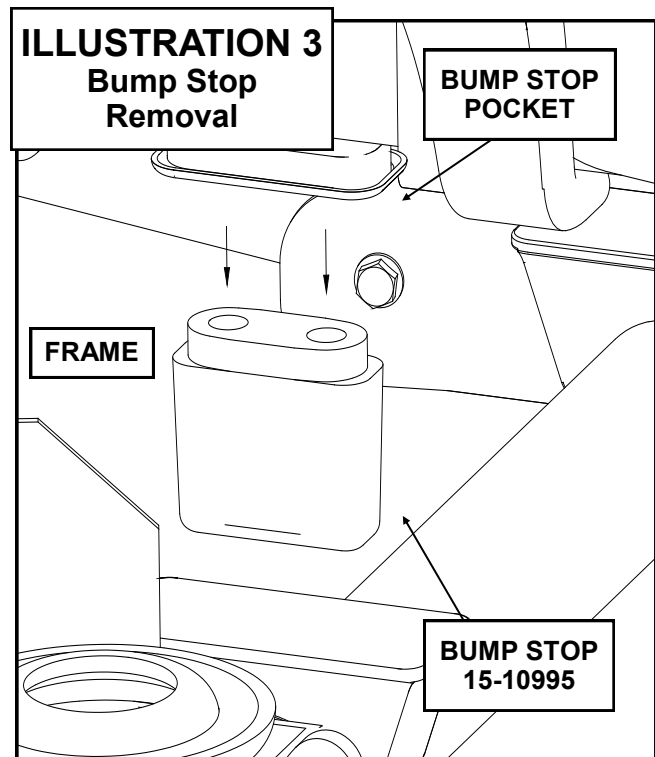

22. Using a suitable cutting tool, (abrasive cutoff

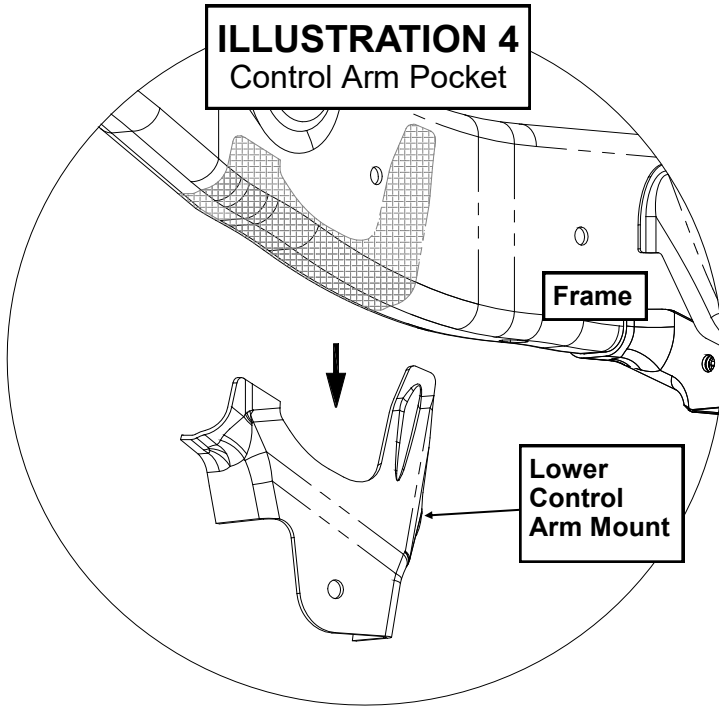

wheel, Sawz-all, etc.) cut off the lower arm mounting pocket as shown in ILLUSTRATION 4. After cutting the lower arm mounting pockets, sand the frame smooth. Clean the area thoroughly and paint the exposed metal with a good quality paint.

IMPORTANT!: Be sure not to cut into fuel or brake lines. DO NOT cut into the frame rail. This will weaken the frame structure considerably.

23. Raise the control arm bracket (**91-5340 drv** and **91-5351 pass**) into place on the frame. Secure the bracket tightly against the frame using the previously removed **OE** crossmember bolts. Clamp the bracket securely against the frame in the front in the rear. See ILLUSTRATION 5.
24. Use the bracket as a guide to center punch and drill the hole in the upper arm mount location. Drill the hole using a **9/16"** drill bit. Be sure to drill through both sides of the frame. See ILLUSTRATION 5.
25. Remove the control arm bracket from the frame. Drill the **9/16"** hole to **7/8"** to make room for the crush sleeve. See ILLUSTRATION 6.

26. Install the **7/8"** crush sleeve (**90-2908**) into the frame. See ILLUSTRATION 6.

NOTE: Placing clear packing tape over the outside of the frame and crush sleeve will help hold the crush sleeve in it's proper position. Poke holes in the tape so the bolt will pass through the sleeve and the frame properly.

27. Locate the control arm bracket (**91-5340 drv** and **91-5351 pass**) on the frame by installing the **9/16"** X **7"** bolt through the crush sleeve. Do not install the washers or nuts to this **9/16"** bolt. Secure the control arm bracket to the frame using the supplied **1/2"** X **1 1/4"** front lower bolt and **1/2"** nut and washer.

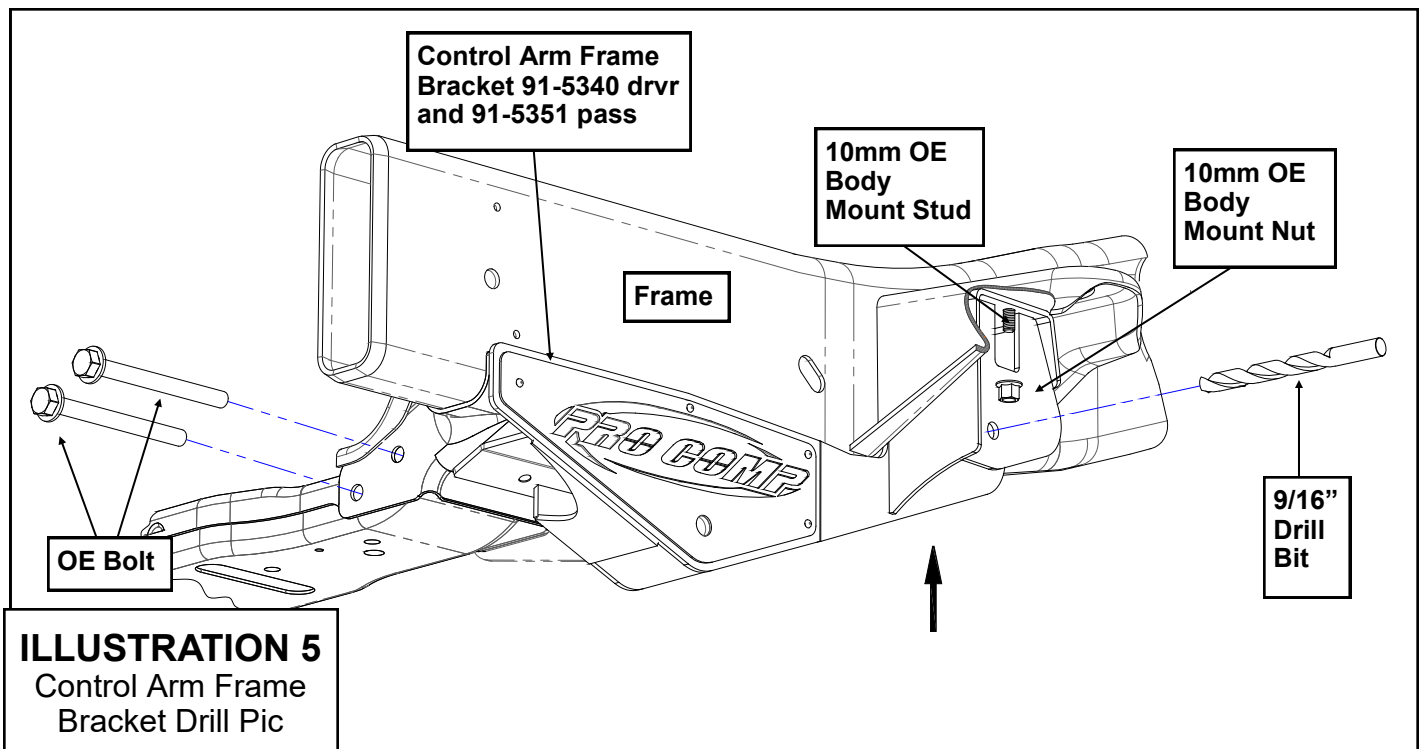
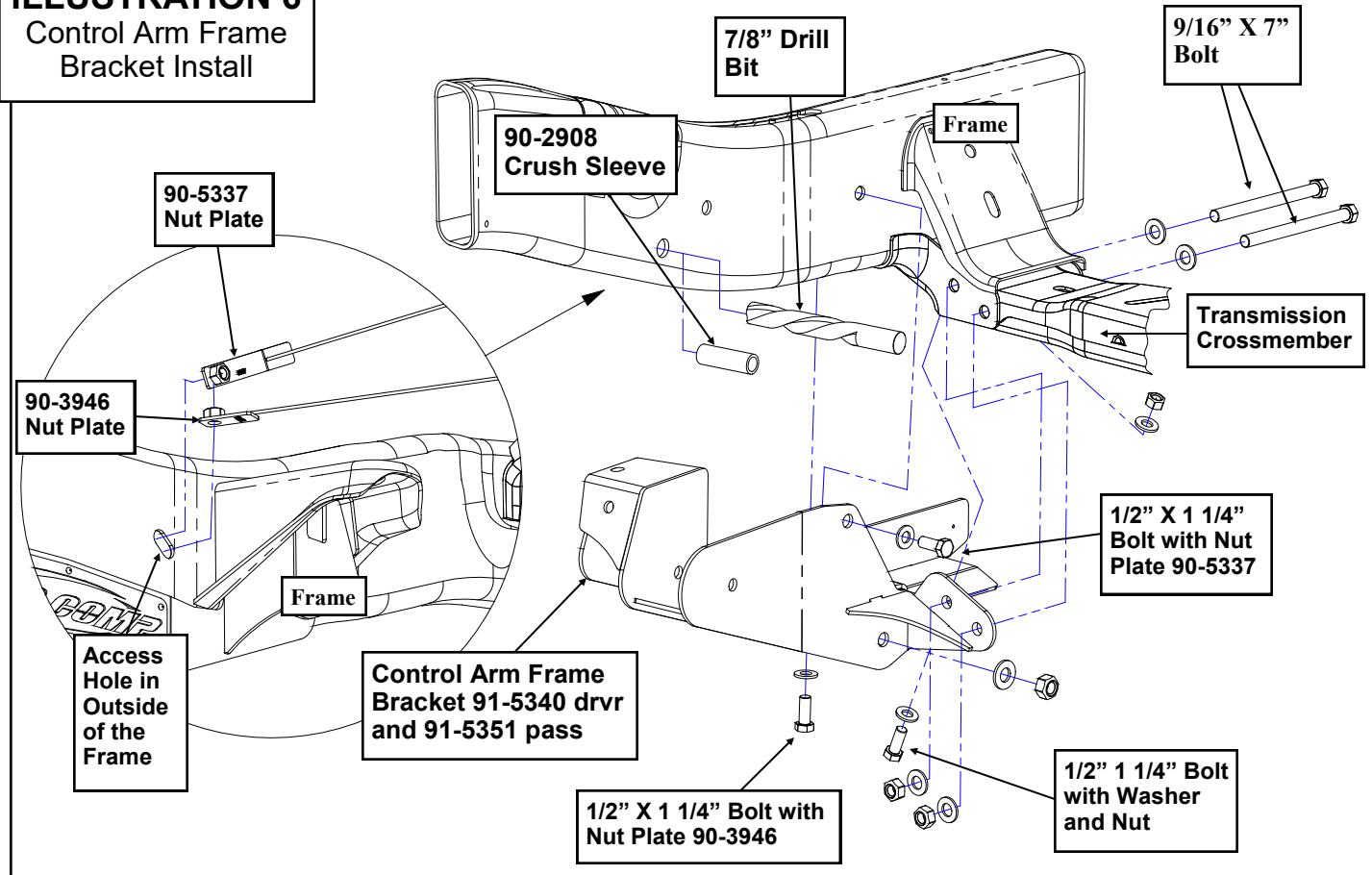

ILLUSTRATION 6
Control Arm Frame
Bracket Install



Install the **1/2" X 1 1/4"** front inner bolt and secure using nut plate (**90-5337**). Install the **1/2" X 1 1/4"** rear lower bolt and secure using nut plate (**90-3946**). Install the nut plates through the oval hole on the outside of the frame rail. See ILLUSTRATION 6.

28. Secure the transmission crossmember using the (2) supplied **9/16" X 7"** bolts and hardware through the control arm bracket and frame. See ILLUSTRATION 6.
29. With the control arm bracket bolted securely in place, install the front upper drill templates (**96-5364 front drv**, **96-5365 rear drv** and **96-5366 front pass**, **96-5367 rear pass**). Place the drill templates on the front and rear face of the body mount. Bend the tabs on the drill template to engage the surface of the frame and not the weld. Clamp the drill template in place. See ILLUSTRATION 7.
30. Drill through the pilot hole using a **1/8"** drill bit. Remove the drill templates and drill the **1/8"** hole to **1/2"**. Install the **1/2" X 1 1/4"** bolts and hardware (front and rear). See ILLUSTRATION 7.
31. Torque control arm frame bracket mounting

hardware according to the chart on page 21.

NOTE: Except the 9/16" X 7" upper control arm bracket retaining bolt.

32. Install the bushings (**15-11325**) and sleeves (**90-2781**) from hardware pack (**90-6648**) into the new upper control arms. See ILLUSTRATION 8.
33. Remove the previously installed **9/16" X 7"** upper control arm mounting bolt from the bracket. Install the new upper control arm (**90-2909**) into the mounting location in the control arm bracket. Secure the upper arm (**91-2909**) the previously removed **9/16" X 7"** bolt and hardware. Refer to ILLUSTRATION 8.
34. Use the previously removed **OE** hardware to fasten the upper control arm to the front axle. See ILLUSTRATION 8. Do not torque at this time.
35. Install the bushings (**15-10980**) and sleeves (**90-2101**) from hardware pack (**90-6679**) into the new lower control arm (**91-2911**) as shown in ILLUSTRATION 8. Use the lubricant as necessary. Install the supplied sleeves.

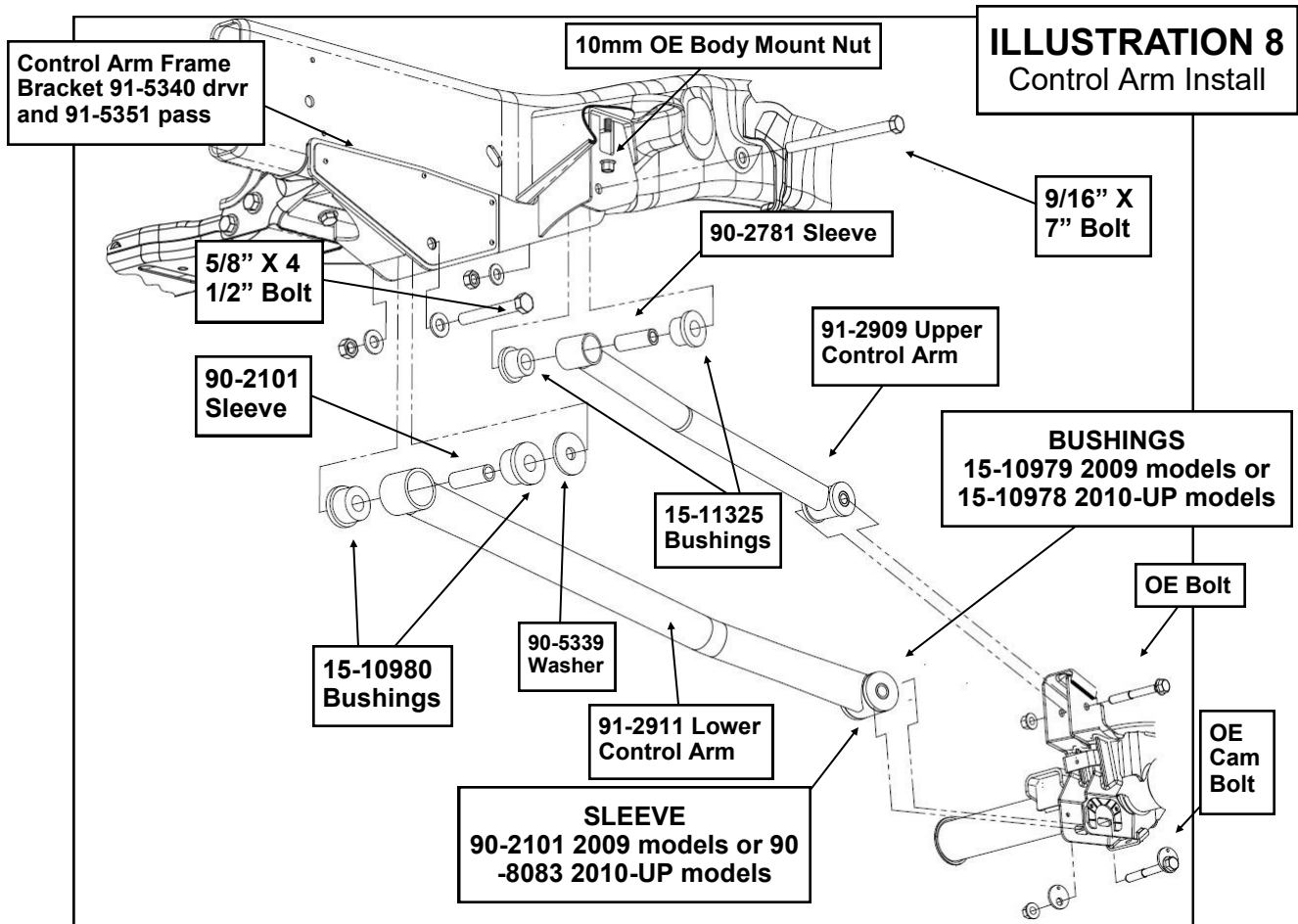
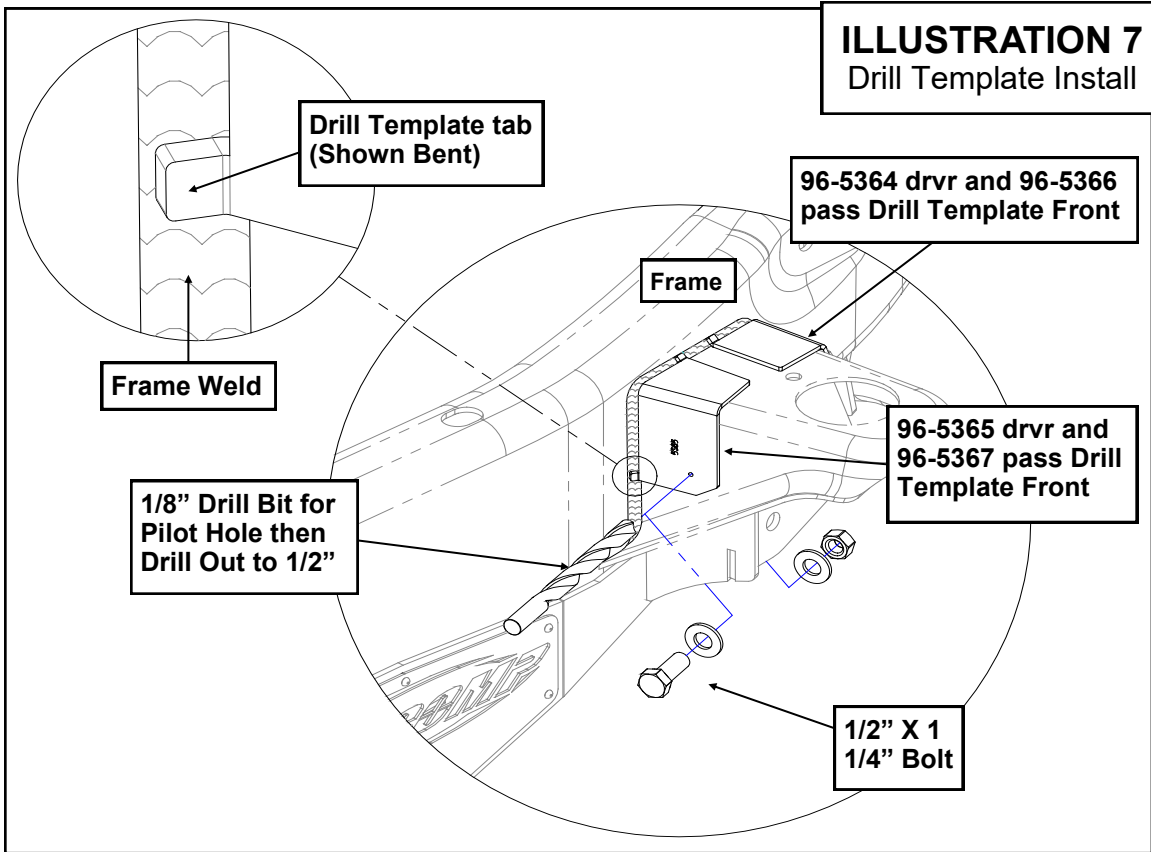

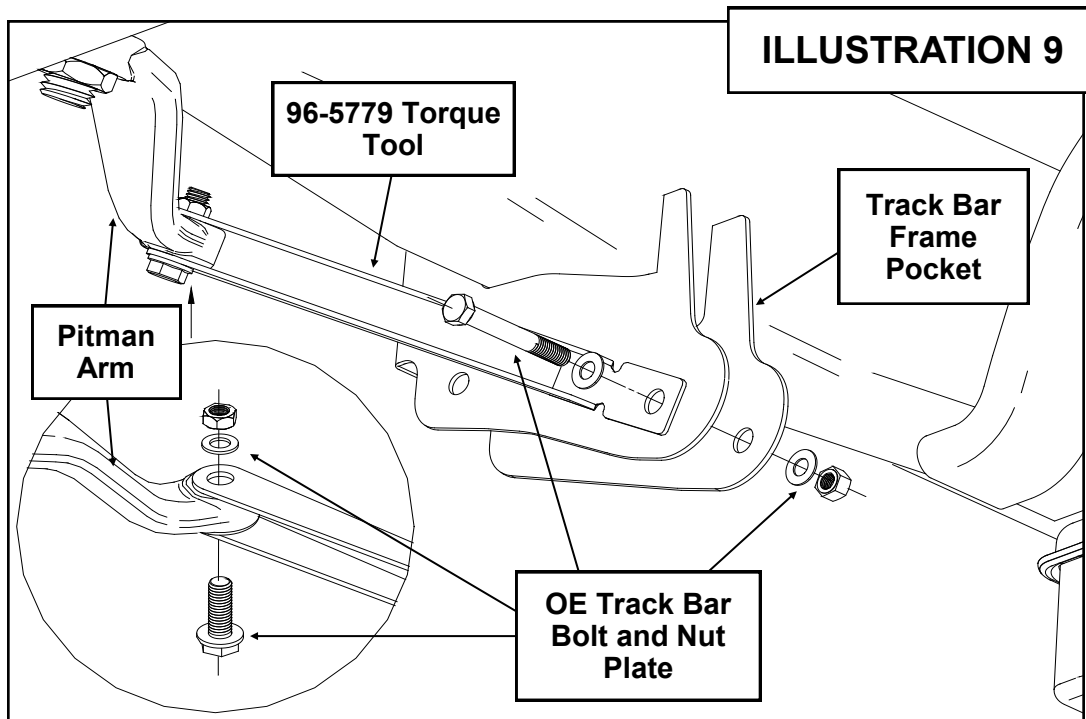

IMPORTANT!: 2010 models: Install the bushings PN 15-10978 and sleeves 90-8083 from hardware pack 90-6748 into the new lower control arm front arm axle end as shown in ILLUSTRATION 8.

36. Install the rear of the lower control arm to the control arm bracket, with the short bend facing inward and to the front of the truck, using the supplied 5/8" X 4 1/2" bolt, lower control arm washer (90-5339) and hardware. Secure the new lower control arm (91-2911) to the front axle using the OE hardware. Do not torque fasteners at this time. See ILLUSTRATION 8.

NOTE: Rotating the lower adjusting cam-bolt may help installation.

37. Tighten but do not torque the control arms at this time.
38. Repeat this procedure on the remaining side of the vehicle.
39. Remove the sector shaft Pitman arm retaining nut and save for reinstallation. Use a Pitman arm puller to remove the OE pitman arm. The threads of the sector shaft and the Pitman arm retaining nut must be cleaned of all factory dry adhesive.

IMPORTANT!: THE ENTIRE INSTALLATION PROCESS MUST BE DONE WITH HAND

TOOLS TO ENSURE PROPER INSTALLATION. DO NOT USE IMPACT TOOLS.

39. Install new pitman arm on sector shaft. Oil the sector shaft threads to ensure a proper torque reading. Install Pitman arm retaining nut and tighten until snug.
40. Insert the key and unlock the steering wheel.
41. Install the Pitman arm torque tool (96-5779) to the Pitman arm using one of the previously removed OE track bar bolt and nut plate. See ILLUSTRATION 9.
42. Secure the torque tool (96-5779) to the existing hole in the track bar frame mounting pocket using one of the previously removed OE track bar bolt and nut plate. See ILLUSTRATION 9.

NOTE: The steering wheel may need to be turned in order for the hole in the torque tool and the frame crossmember to line up. Once the bolts are tightened the torque tool will align it's self properly.

NOTE: The use of the torque tool is to keep the Pitman arm from moving right or left, but allow for movement up the sector shaft. If you do not have this tool, a length of chain or a flat bar with two holes is a suitable replacement.

43. Torque the Pitman arm retaining nut to 225 ft.-lbs.

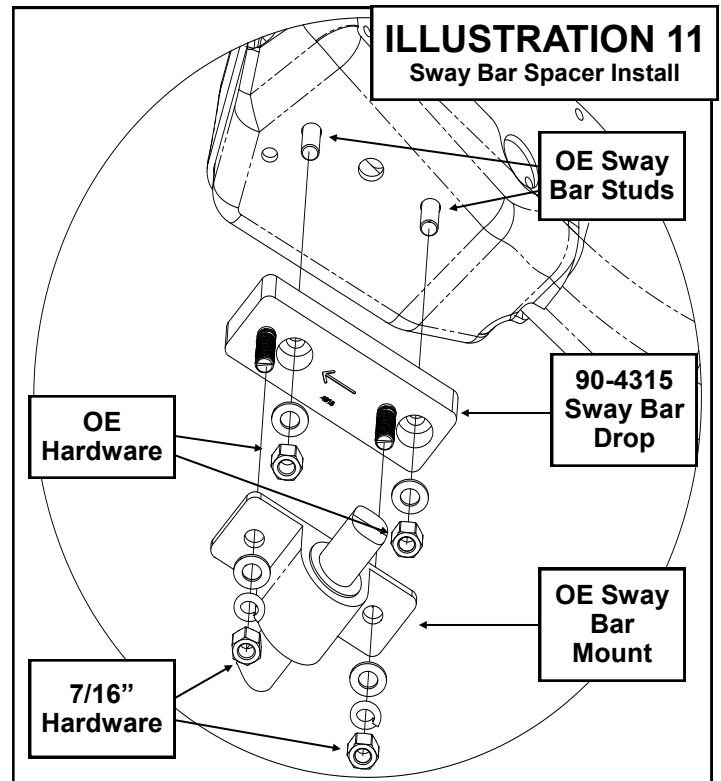
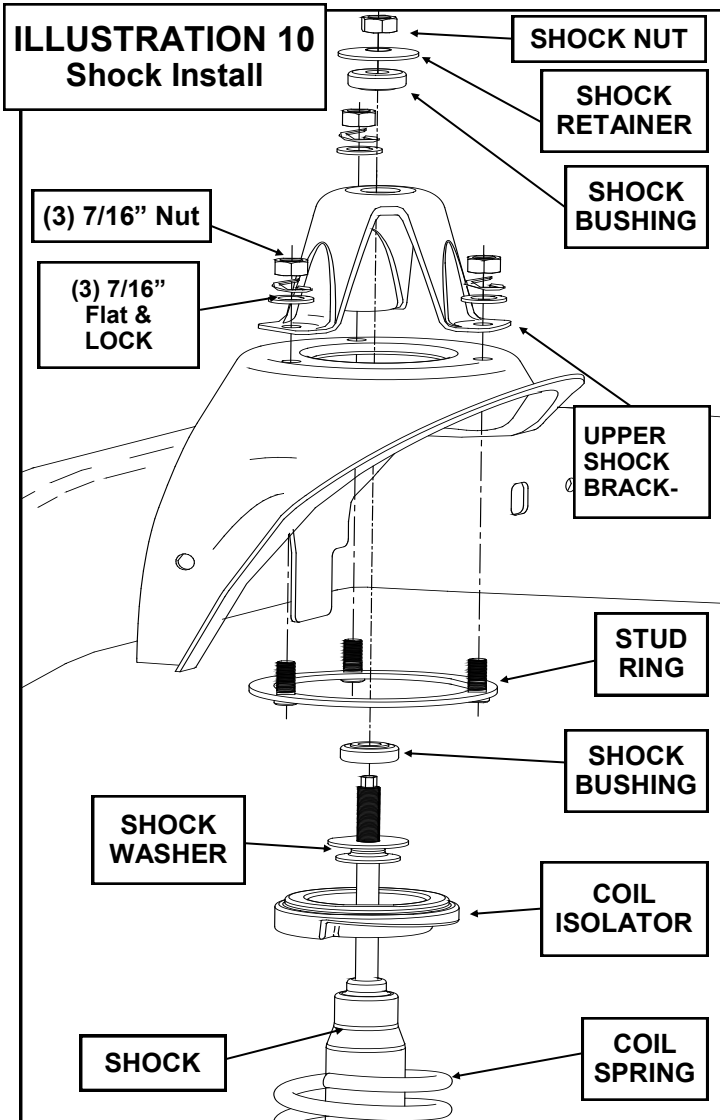

44. With the torque tool (96-5779) still in place remove the pitman arm retaining nut. The threads of the sector shaft and the Pitman arm retaining nut ***MUST*** be cleaned using brake cleaner or another suitable method to remove the previously applied oil.

45. Use the entire supplied thread locking compound to thoroughly cover the entire surface of the threads on the Pitman arm retaining nut.

46. Reinstall the Pitman arm retaining nut to the sector shaft and torque to 225 ft.-lbs.
NOTE: Whether re-using the existing pitman arm retaining nut or replacing with a new nut, thread locking compound must be used.

47. Unbolt and remove the Pitman arm torque tool (96-5779) from the vehicle.

NOTE: Save this Pitman arm torque

tool to add to your toolbox for any future Pitman arm installations.

48. Install the previously removed OE stud ring into the upper spring pocket. See ILLUSTRATION 10. Temporarily install the (3) previously removed OE nuts to hold the stud ring in place.

49. Install the factory spring isolator onto the supplied Pro Comp coil springs (56160 diesel or 56170 gas). Carefully compress and install the Pro Comp coil springs (56160 diesel or 56170 gas) into the spring buckets. Raise the front axle into place and make sure the coil spring is indexed properly on the lower spring perch.

50. Install your new Pro Comp shocks (ZX2009) through the coil spring from the engine compartment. Install the lower shock bolt. Torque the lower bolt to 100 ft./lbs. See ILLUSTRATION 10.

51. Remove the OE stud ring nuts. Install the upper shock bracket to the stud ring. Install the upper shock mount using the grommet and retainer, fastening the shock stud to the shock bracket with the upper shock nut. Torque the (3) OE shock bracket nuts to 55 ft./lbs.

52. Install the sway bar drop brackets (90-4315) to the original sway bar mounting studs in the frame using the previously removed OE

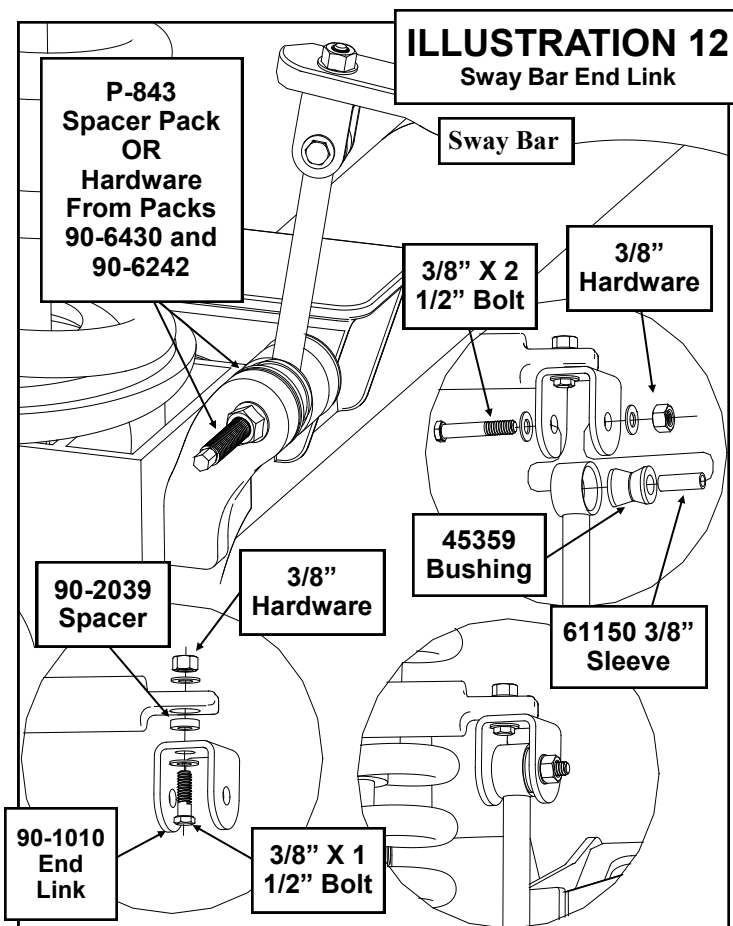

hardware. Torque to 45 ft./lbs. See ILLUSTRATION 11.

IMPORTANT: Be sure that the drop brackets are offset toward the front of the vehicle.

53. Raise the sway bar mount brackets to the studs on the drop bracket (90-4315) and secure using the supplied 7/16" hardware from pack (90-6676). Torque the hardware according to the torque chart on page 21. See ILLUSTRATION 11.
54. Assemble and install to the axle the sway bar link (90-2357) with the bushings and P-843 hardware from pack (90-6312). See ILLUSTRATION 12.

NOTE: Some models may have a 14mm lower sway bar hole. If so, use the 14mm bolts and hardware from pack (90-6430), lower bushings and sleeves from pack (90-6242) on the bottom to attach the links to the axle.

55. Use the 3/8" X 1 1/2" bolt and 3/8" washers and nuts from (90-6024) to attach the (90-1010) to the sway bar end. Use the 3/8" X 2 1/2" hardware from (90-6024) to attach the

(90-2357) to the (90-1010). See ILLUSTRATION 12.

56. Repeat on the other side of the vehicle.
57. Torque the supplied sway bar hardware according to the torque chart on page 21.
58. Install the hose clamps and screws from hardware pack (90-6029) to the brake lines.
59. Bolt the front brake line extension brackets (90-1539) to the original OE brake line bracket holes, on the front axle brackets, using the previously removed OE bolts.
60. Secure the OE brake lines to the brake line extension brackets (90-1539) using the supplied 5/16" X 1" bolt and hardware.
61. Install your wheels and tires and lower the vehicle to the ground. Tighten the lug nuts to 90 ft./lbs.
62. Torque the control arm frame mounting bracket bolts to specifications chart in the rear of the instructions. Torque the upper control arm axle mounting bolt to 120 ft./lbs. and the lower control arm axle mounting bolt to 140 ft./lbs.
63. Drill out the existing track bar mounting hole in the frame to 5/8".
64. Secure the track bar drop bracket (91-7658) to the frame mounting pocket by inserting the 5/8" X 4 1/2" bolt, from the backside, 5/8" hardware and (90-8231 long sleeve, in between the OE frame mounting pocket and the 90-8232 short sleeve, in front of the OE frame mounting pocket and the backside of the track bar drop bracket 91-7658). See ILLUSTRATION 13.
NOTE: Be sure to use thread locker on this bolt. DO NOT the bolt torque at this time.
65. Insert the 7/16" X .788" split sleeve (61734) into the crossmember hole closest to the driver side track bar mount. Insert the 3/4" X 1 1/2" crossmember sleeve (90-8233) in the center hole in the crossmember. See ILLUSTRATION 13.
66. Rotate the track bar drop (91-7658) up into place and secure using 1/2" X 2 1/2" bolt and track bar nut (90-4460) in the center hole and the 7/16" X 3" bolt, 90-7882 washer and hardware in the remaining hole. See ILLUSTRATION 9. Torque the track bar drop mounting hardware according to the

ILLUSTRATION 13

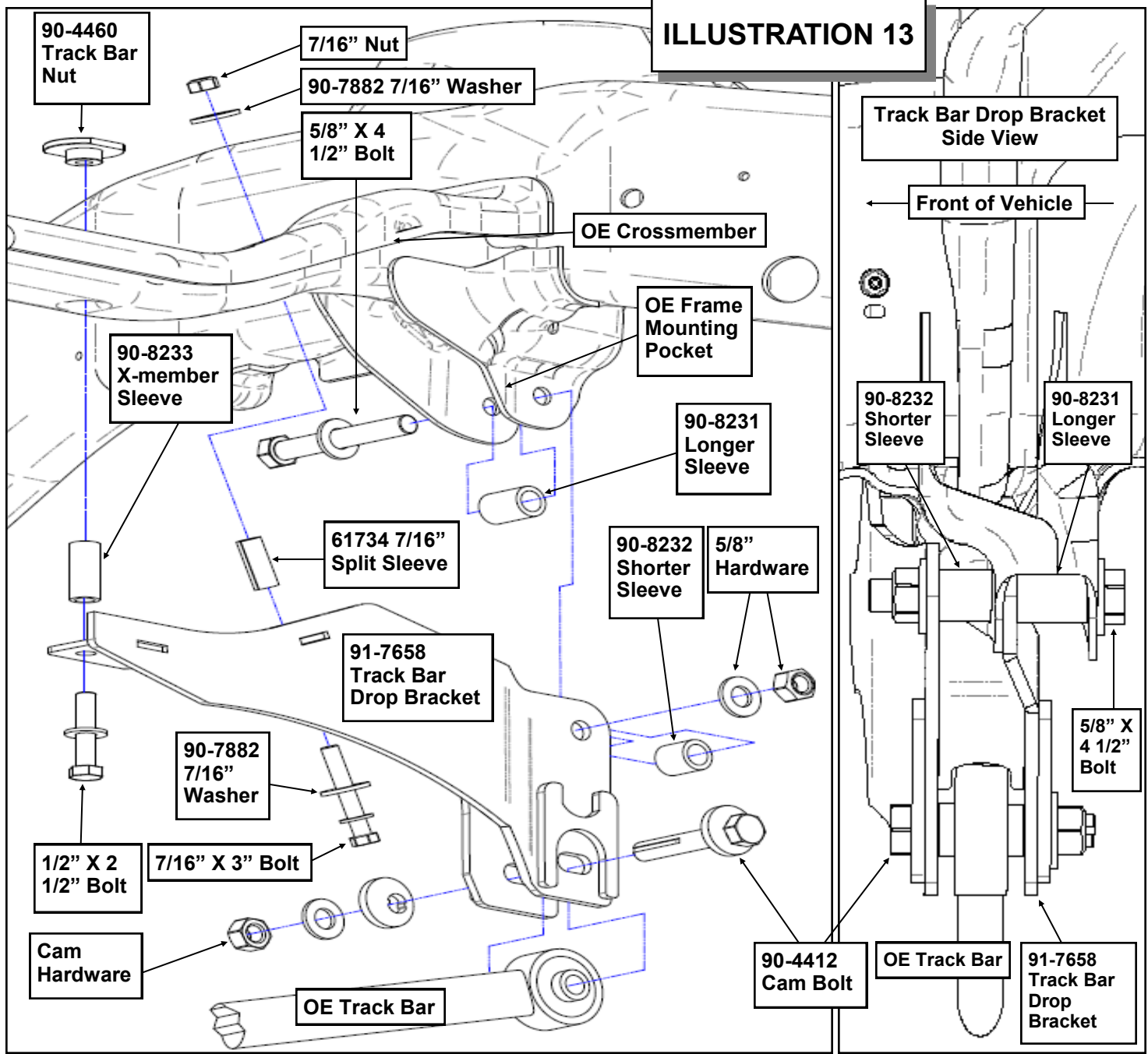

chart on page 15. Torque the **5/8" X 4 1/2"** bolt to **175** ft./lbs.

NOTE: Be sure to use thread locker on these bolts.

67. Reinstall the **OE** track bar using the previously removed **OE** hardware at the axle end and the new adjustable cam bolt (**90-4412**) and cam hardware from hardware pack (**90-6852**) in the new frame mount end (**91-7658**). Be sure to install the cam with the head of the bolt facing the front of the vehicle. Do not torque the cam bolt at this time. **See ILLUSTRATION 13.**

ILLUSTRATION 13.

68. With the vehicle on the ground, measure from the outside edge of the tires to the edge of the wheel well on the fenders. Use the cam to center the axle under the vehicle by rotating the cam until the measurement is equal on both sides. Torque the cam bolt to **150** ft./lbs.
69. See the driveshaft note on page 15. **See ILLUSTRATION 14.**

DRIVE SHAFT NOTE: WHILE THE TRUCK IS IN THE AIR SPIN THE FRONT DRIVE SHAFT. IF THE FRONT DRIVE SHAFT BINDS AT FULL DROOP THE JOINT CAN BE TRIMMED. YOU CAN GRIND THE OUT SIDES OF THE CLOSE JOINTS ON BOTH SIDES. YOU WILL ALSO NEED TO GRIND THE INSIDE OF THE FAR JOINTS ON BOTH SIDES. USE THE ILLUSTRATION TO GUIDE YOU. YOU SHOULD HAVE THE DRIVESHAFT BALANCED BY A QUALIFIED SHOP WHEN YOU ARE FINISHED.

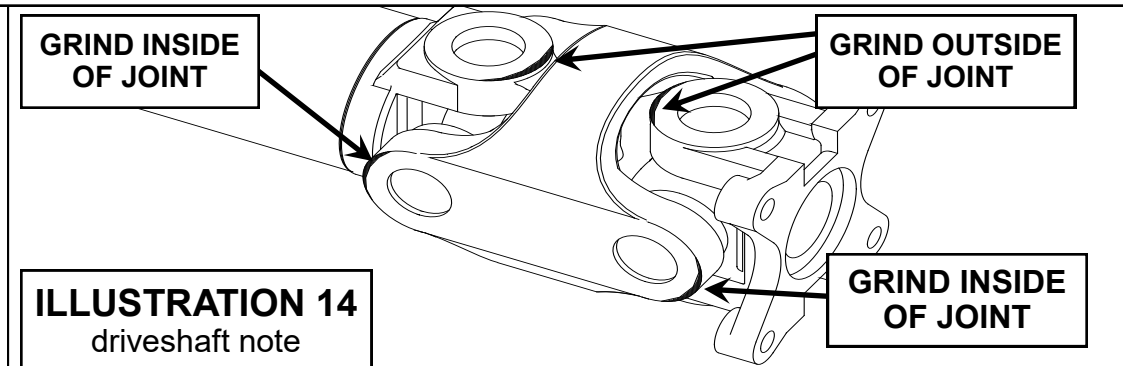

70. With the vehicle on the ground, re-attach sway bar end links. Torque down end links and sway-bar bolts.
71. On both sides of the vehicle, check the routing of the brake lines and the ABS wire harnesses. There must be no pinching, rubbing, or stretching of any component. Use zip ties to secure these items out of the way of the steering components. At full droop, cycle the steering from lock to lock while observing the reaction of these components. Reposition them if needed.
72. Recheck for proper installation and torque, of all of the newly installed hardware and after any off road use.
73. Have your vehicle aligned.
74. Have your headlights adjusted.
75. After 100 miles recheck for proper torque on all newly installed hardware

Rear Installation

1. Block the front tires and raise the rear of the vehicle. Support the frame with jack stands forward of the rear springs.
2. Remove the wheels and tires.
3. Remove the shocks on both sides of the vehicle. It may be necessary that you slightly raise the axle to unload the shocks for removal.
4. Remove the factory bump stop from the frame.
5. Fit 2 of the new BUMP STOP BRACKETS **90-3081** together as shown in ILLUSTRATION A. Then bolt to the frame using the factory bolts.
6. Using the hardware from pack **90-6223** bolt the bump stop to the brackets. As shown in ILLUSTRATION A.
7. Repeat the installation on the other side of the vehicle.
8. Loosen the U-bolts on the passenger side. Remove the U-bolts on the drive side.
9. Install the lift block (**95-300D**) on the axle pad and use your floor jack to raise the axle to the spring. Apply a slight amount of pressure with your floor jack against the spring pack and engage the centering pins into the locating holes at the top of the lift block.

NOTE: The factory spring pack will have two metal pins on the bottom, it may have a third plastic pin in the center. To install the lift block this plastic pin can be removed with a pair of pliers.

10. Secure the assembly with the U-bolts **13-90330** and new high-nuts and washers from hardware pack **20-65302**. Do not tighten the U-bolts at this time. See ILLUSTRATION B.

NOTE: make sure the block sits flush on the axle perch.

NOTE: If the vehicle is equipped with a Dana 80 rear end, use U-bolts 13-90328 and hi-nuts 20-65471. The holes in the spring plate will need to be drilled out to accommodate the new larger U-bolts.

11. Repeat the installation on the other side of the vehicle.

12. When the installation of the remaining side is complete, torque the U-bolts to 85 ft. lbs.

13. Install your new Pro Comp shocks (**ZX2001**) and torque this hardware to **60 ft./lbs.**

NOTE: When fitting the Fox reservoir, make sure the fitting and the braided line have adequate space and do not contact anything. Also make sure there are

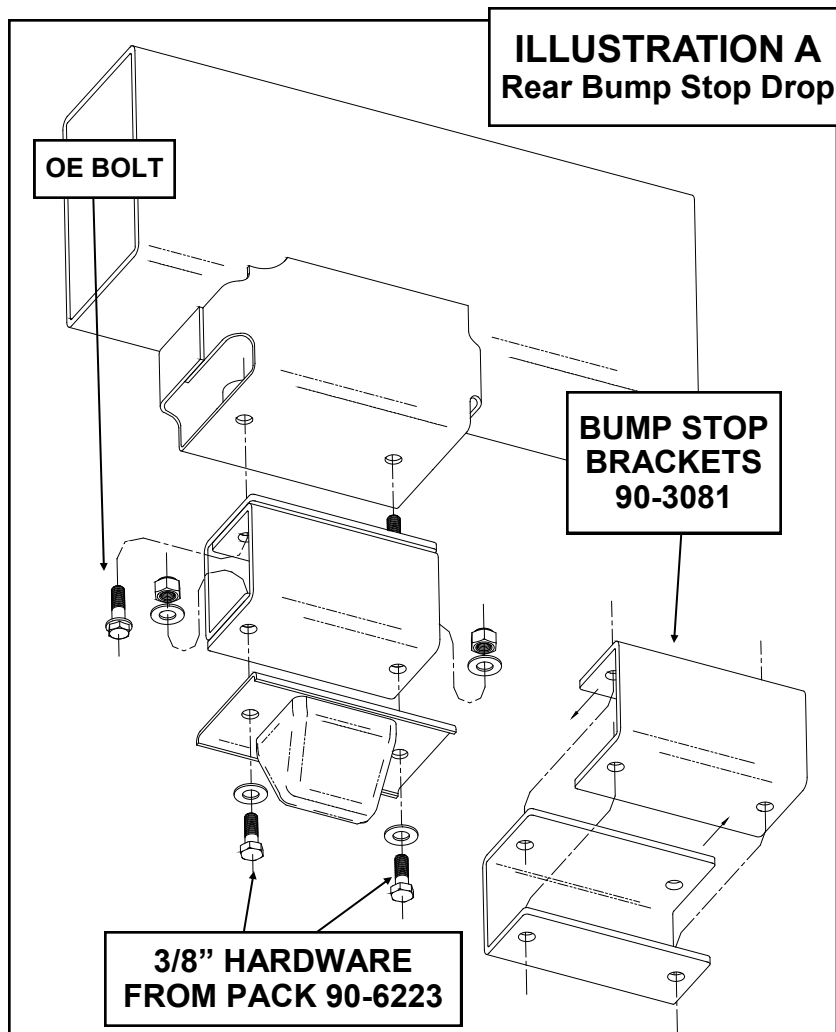

no kinks in the lines. Secure to the reservoir to the desired location using the supplied hardware.

14. Reinstall the wheels and tires and lower the vehicle to the ground.

15. Recheck the wheel lug torque on all four wheels at this time.

16. Recheck all hardware for proper installation and torque at

this time.

17. After test driving: If there is a rear drive line vibration you can install shim kit **51255** with hardware pack **90-6327**. Try various combinations until the vibration is eliminated.

NOTES:

⇒ **After 100 miles recheck for proper torque on all newly installed hardware.**

⇒ **Have your headlights adjusted.**

**ILLUSTRATION B
Rear Suspension**

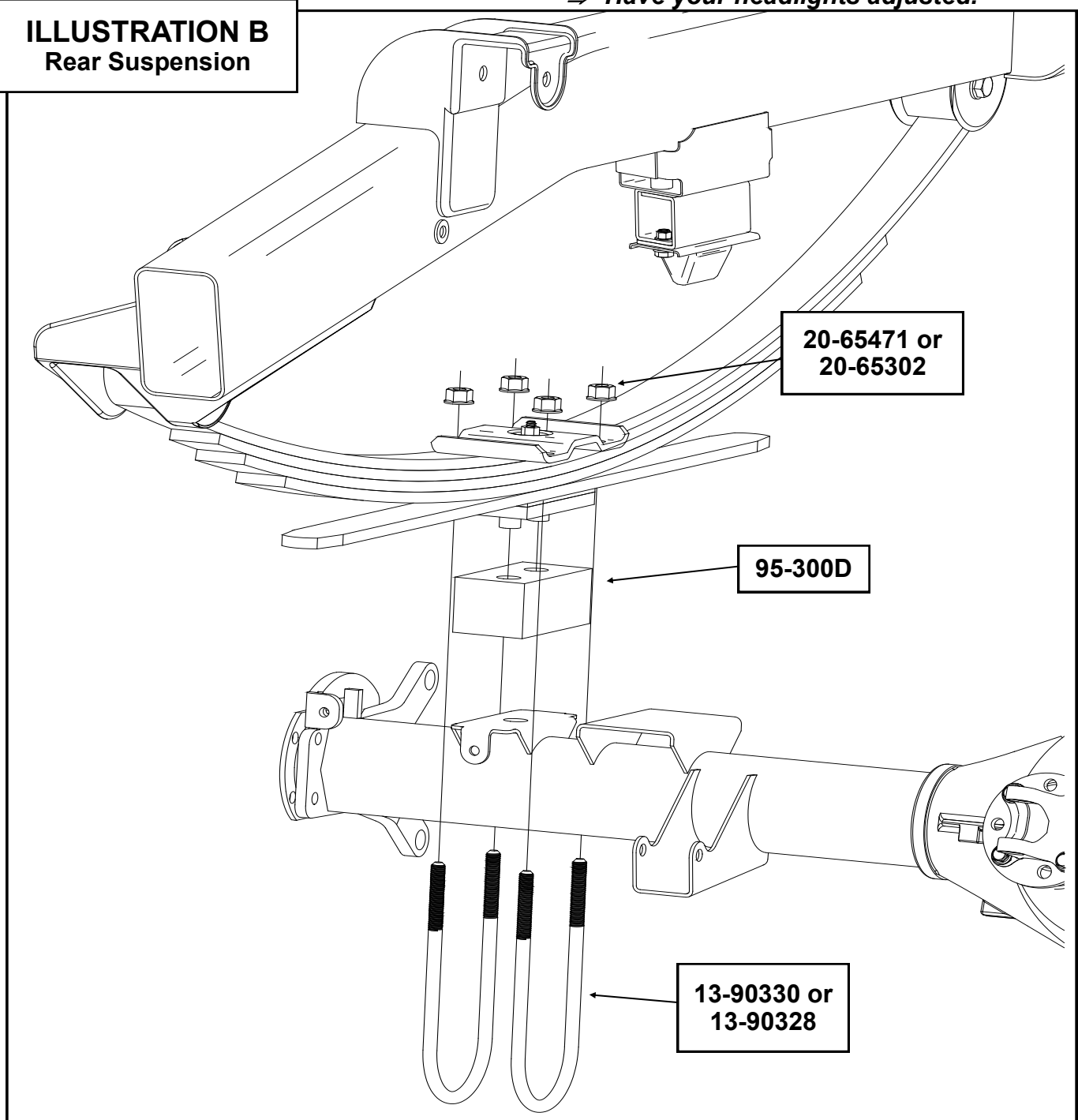

⇒ ***Recheck all hardware for tightness after off road use.***

REVISION PAGE:

9.23.12: Removed 56714 BOM box-3 and added the contents of 56716 box-2 to the BOM box-3. Changed Illustration #13 and the track bar installation text to reflect the part changes.

11.9.12: Removed 90-3561, 96-5068 and 90-6268 from BOM box-1.

12.7.12: Removed BF/BFR & MXR shocks from the text and from BOM box-4. Modified options box information and front sway bar end link illustration #12.

1.10.13: Added the side view illustration to illustration 13. Removed note about not re-using OEM cam bolts from pg. 12.

7.30.13: Added BP information to the cover box.

2.2.15: Changed Pitman arm PN from DC600-1 to DC601-1.

2.19.15: Changed Pitman arm retaining nut torque value to 225 ft./lbs.

8.19.21: Added T & M Instance to K2078.

Bolt Torque and ID						
Decimal System			Metric System			
All Torques in Ft. Lbs.						
Bolt Size	Grade 5	Grade 8	Bolt Size	Class 9.8	Class 10.9	Class 12.9
5/16	15	20	M6	5	9	12
3/8	30	45	M8	18	23	27
7/16	45	60	M10	32	45	50
1/2	65	90	M12	55	75	90
9/16	95	130	M14	85	120	145
5/8	135	175	M16	130	165	210
3/4	185	280	M18	170	240	290

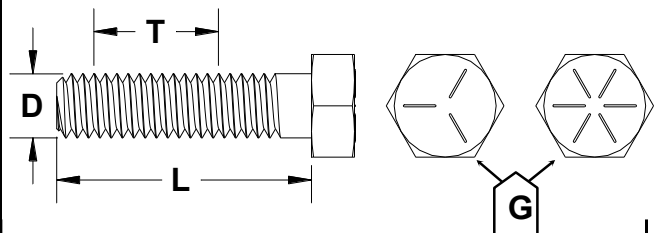
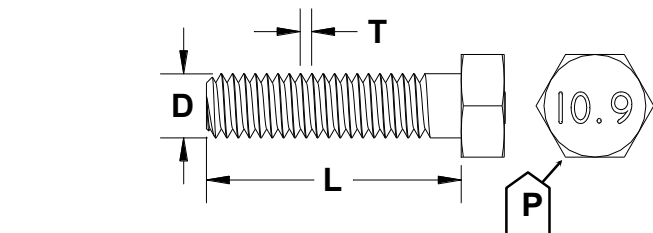
 <p style="margin-top: 10px;">1/2-13x1.75 HHCS Grade 5 Grade 8 (No. of Marks + 2)</p> <p style="margin-top: 10px;"> D T L X </p>	 <p style="margin-top: 10px;">M12-1.25x50 HHCS</p> <p style="margin-top: 10px;"> D T L X </p>
<p>G = Grade (Bolt Strength)</p> <p>D = Nominal Diameter (Inches)</p> <p>T = Thread Count (Threads per Inch)</p> <p>L = Length (Inches)</p> <p>X = Description (Hex Head Cap Screw)</p>	<p>P = Property Class (Bolt Strength)</p> <p>D = Nominal Diameter (Millimeters)</p> <p>T = Thread Pitch (Thread Width, mm)</p> <p>L = Length (Millimeters)</p> <p>X = Description (Hex Head Cap Screw)</p>



The PRO COMP PROMISE WARRANTY

At Pro Comp, we know you have many choices when selecting products to personalize your vehicle. You should demand nothing but the highest quality available and have total confidence that the products you selected are the best in the industry. It is for these reasons that Pro Comp Suspension products are backed by the best warranty in the industry...the Pro Comp Promise!

Pro Comp promises that its products will last a lifetime or we will replace it free of charge. It's that simple! Because of our commitment to quality and manufacturing excellence, we are able to stand behind our products. FOREVER.

It is Pro Comp's Promise that if one of our suspension products breaks not due to misuse, neglect or vandalism, we will replace it. Whether you are the original purchaser or not, you can be assured that we will make it right. The Pro Comp Promise covers all suspension products including shocks and steering stabilizers. Buy Pro Comp Suspension today and enjoy it for the rest of your life!

That's our Pro Comp Promise!

Notice to Owner, Operator, Dealer and Installer:

Vehicles that have been enhanced for off-road performance often have unique handling characteristics due to the higher center of gravity and larger tires. This vehicle may handle, react and stop differently than many passenger cars or unmodified vehicles, both on and off-road. You must drive your vehicle safely! Extreme care should always be taken to prevent vehicle rollover or loss of control, which can result in serious injury or even death. Always avoid sudden sharp turns or abrupt maneuvers and allow more time and distance for braking! Pro Comp reminds you to fasten your seat belts at all times and reduce speed! We will gladly answer any questions concerning the design, function, maintenance and correct use of our products.

Please make sure that the Dealer / Installer explains and delivers all warning notices, warranty forms and instruction sheets included with Pro Comp product.

Warranty and Return Policy:

Pro Comp warrants its full line of products to be free from defects in workmanship and materials for the life of the product. Pro Comp's obligation under this warranty is limited to repair or replacement, at Pro Comp's option, of the defective product. Any and all costs of removal, installation, freight or incidental or consequential damages are expressly excluded from this warranty. Pro Comp is not responsible for damages and / or warranty of other vehicle parts related or non-related to the installation of Pro Comp product. A consumer who makes the decision to modify his vehicle with aftermarket components of any kind will assume all risk and responsibility for potential damages incurred as a result of their chosen modifications. Warranty coverage does not include consumer opinions regarding ride comfort, fitment and design. Warranty claims can be made directly with Pro Comp or at any factory authorized Pro Comp dealer.

IMPORTANT! To validate the warranty on this purchase please be sure to mail in the warranty card.

Claims not covered under warranty

* Parts subject to normal wear; this includes bushings, bump stops, ball joints, tie rod ends and heim joints.

* Finish after 90 days.

* Damage caused as a result of not following recommendations or requirements called out in the installation manuals.

Pro Comp MX Series coil-over shocks are considered a serviceable shock with a one-year warranty against leakage only. Rebuild service and replacement parts will be available and sold separately by Pro Comp. Contact Pro Comp for specific service charges. Pro Comp accepts no responsibility for any altered product, improper installation, lack of or improper maintenance or improper use of our products.

E-Mail: info@procompusa.com
Website: www.procompusa.com
Fax: (310) 747-3912
Ph: 1-800-776-0767

<u>PLACE</u> <u>WARRANTY REGISTRATION</u> <u>NUMBER</u> HERE: _____
