



## Installation Instructions

### Jeep JL Front Grumper

Product Number: GR4600

Application: '18+ JEEP JL

## **! IMPORTANT SAFETY GUIDE**

- Your safety and the safety of others is very important.
- In order to help you make informed decisions about safety, we have provided the following warnings, safety precautions, installation instructions, and other important information to alert you to potential hazards that could hurt you or others.
- Please do a job safety analysis before each task to identify potential hazards for your situation and remove/protect against them.
- Use own good judgment and take your time.
- Check packaged materials immediately upon arrival to ensure that all listed parts are included and undamaged.

**Read and understand all warnings, safety precautions, and instructions before installing this product.**

**SENSORS FIELD OF VIEW WILL BE ALTERED WITH USE OF THE REPLACEMENT BUMPER.**

## **WARNINGS**

- **FAILURE TO OBSERVE THE FOLLOWING WARNINGS AND INSTRUCTIONS PROVIDED IN THIS MANUAL COULD LEAD TO SEVERE INJURY AND/OR DEATH.**
- **FOR PROFESSIONAL INSTALLATION ONLY. CARELESS INSTALLATION AND/OR OPERATION CAN RESULT IN SERIOUS INJURY, DEATH, AND/OR EQUIPMENT DAMAGE. ALL LIABILITY FOR INSTALLATION AND USE RESTS WITH THE USER OR CONSUMER.**
- **FAB FOURS, INC. ONLY APPROVES INSTALLING THIS PRODUCT ACCORDING TO THESE WRITTEN INSTRUCTIONS WITH THE HARDWARE PROVIDED. FAILURE TO INSTALL ACCORDING TO THESE INSTRUCTIONS WILL INVALIDATE THE WARRANTY. THIS INCLUDES, BUT IS NOT LIMITED TO, USING ALTERNATIVE INSTALLATION METHODS, HARDWARE, OR MATERIALS.**
- **THIS PRODUCT IS FOR OFFROAD USE ONLY.**





## Installation Instructions

### Jeep JL Front Grumper

Product Number: GR4600

Application: '18+ JEEP JL

## SAFETY PRECAUTIONS

- Always remove jewelry and wear eye protection.
- Always use extreme caution when jacking up a vehicle for work. Set emergency brake and use tire blocks. Locate and use the vehicle manufacturers designated lifting points. Use jack stands.
- Always use appropriate and adequate care in lifting components into place.
- Always ensure components will remain secure during installation and operation.
- Always wear safety glasses when installing this kit. A drilling operation will cause flying metal chips. Flying chips can cause serious eye injury.
- Always use extreme caution when drilling a vehicle. Always disconnect power before welding. Thoroughly inspect the area to be drilled (on both sides of material when possible) prior to drilling, and relocate any objects that may be damaged.
- Always use extreme caution when welding a vehicle. Thoroughly inspect the area to be welded (on both sides of material when possible) prior to welding, and relocate any objects that may be a fire hazard. When welding in a cab, make sure the interior surfaces are covered (*e.g.*, welding blanket) and a fire extinguisher is at hand.
- Always use extreme caution when cutting and trimming during fitting.
- Always tighten all nuts and bolts securely per installation instructions.
- Always route electrical cables carefully. Avoid moving parts, components that become hot, and rough or sharp edges.
- Always insulate and protect all exposed wiring and electrical terminals.
- Perform regular inspections and maintenance on mounts and hardware.
- Tire may rub at max turn or articulation.





# Installation Instructions

## Jeep JL Front Grumper

Product Number: GR4600

Application: '18+ JEEP JL

### I. Overview

Congratulations on your new purchase of the industries' best and only high clearance Jeep JL front Grumper! This Grumper has been **engineered** for strength while reducing weight.

Your Grumper was designed, CNC laser cut, fabricated, and powder coated... all in the U.S.A.

Enjoy the fit and finish of a quality JL front Grumper from Fab Fours Inc!





## Installation Instructions

### Jeep JL Front Grumper

Product Number: GR4600

Application: '18+ JEEP JL

## II. Tools Required

- Flat Head Screwdriver
- Phillips Screwdriver
- Socket Wrench With Extension
- 18mm & 19mm Sockets
- 3/4" & 1/2" Sockets
- Cut off wheel
- 7/16" Open End Wrench
- Plastic Rivet "Christmas Tree" Removal Tool
- 3/16" Allen Wrench
- 5/32" Allen Wrench

## III. Vehicle Preparation

1. Remove the 2 push pin fasteners attaching the closeout panel to the frame.



2. Remove 2 bolts attaching the plastic skid plate to lower frame.
3. Disconnect fog light harness located on passenger side frame rail (if equipped).





## Installation Instructions

### Jeep JL Front Grumper

Product Number: GR4600

Application: '18+ JEEP JL

4. Remove (8) nuts from studs using 18mm socket.

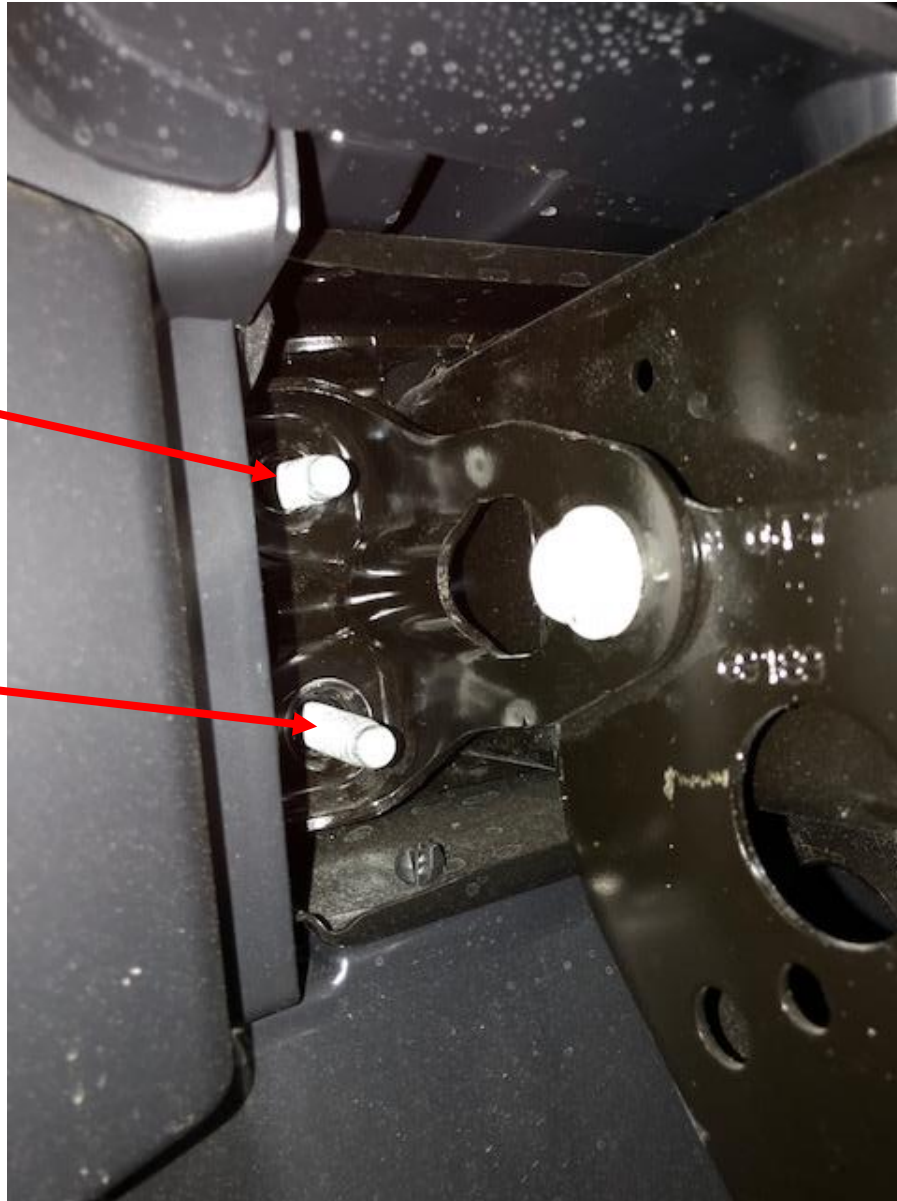

5. Remove OEM bumper and set aside.





## Installation Instructions

### Jeep JL Front Grumper

Product Number: GR4600

Application: '18+ JEEP JL

6. Remove 2 bolts holding skid plate support on and remove support.



Figure 1

7. Opening the hood, locate and remove the 6 push pins at the top of the grille

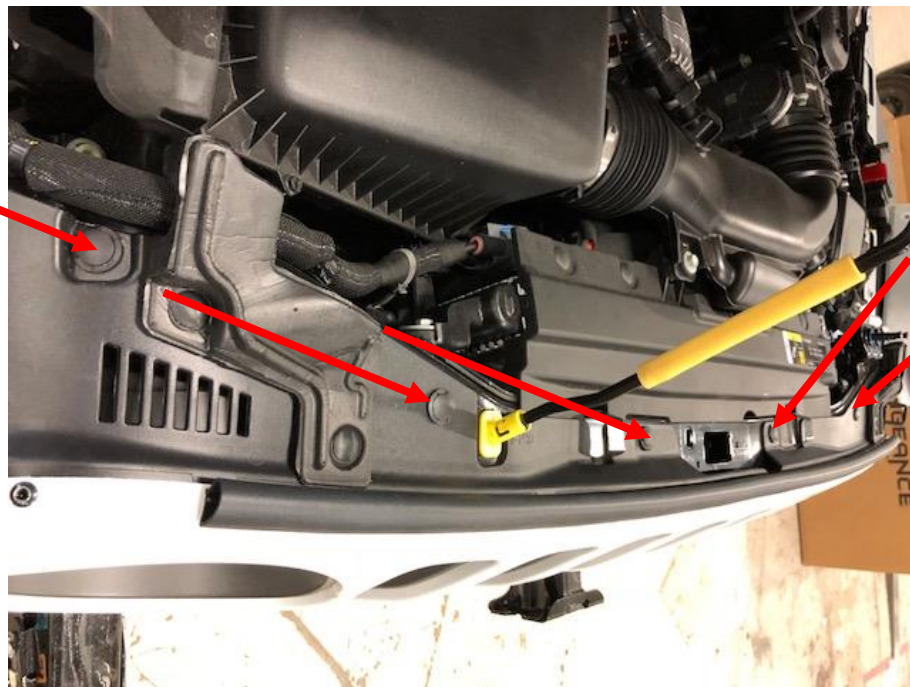



## Installation Instructions

### Jeep JL Front Grumper

Product Number: GR4600

Application: '18+ JEEP JL

8. At this point there are several clips at the base of the grille. Pulling firmly at this location the grille should now be free.





## Installation Instructions

### Jeep JL Front Grumper

Product Number: GR4600

Application: '18+ JEEP JL

9. Remove the 2 (one on each side) rubber pieces located next to the headlights. The driver's side will only have push pins attaching it and the passenger side will have push pins and 2 torx head bolts. If necessary remove the angle support braces to gain access to these and then reinstall.

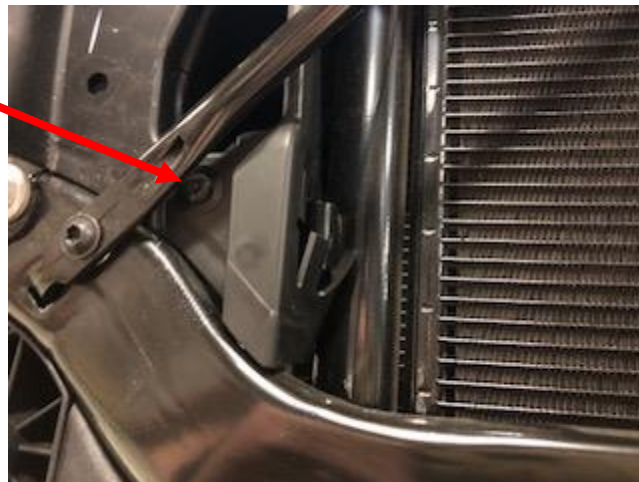





## Installation Instructions

### Jeep JL Front Grumper

Product Number: GR4600

Application: '18+ JEEP JL

10. Remove headlights by removing 3 M6 bolts around the light and disconnecting the harness in the back.





## Installation Instructions

### Jeep JL Front Grumper

Product Number: GR4600

Application: '18+ JEEP JL

#### IV. Vehicle Preparation

1. Locate and install the provided cut templates as shown below on to the plastic headlight supports using the holes and edges to line it up



2. Using a cut off wheel or similar remove the area indicated by the template.
3. Once the area is removed, discard the templates.
4. Reinstall the headlights.





## Installation Instructions

### Jeep JL Front Grumper

Product Number: GR4600

Application: '18+ JEEP JL

#### V. Grumper Preparation

5. Remove the Grumper from the shipping carton. Lay all items out on a non-scratch surface to prevent damage to the powder coating.
6. Using the 5/16" fasteners, install the grille. (if installing a GR4606 do so now in place of the included mesh grille.)

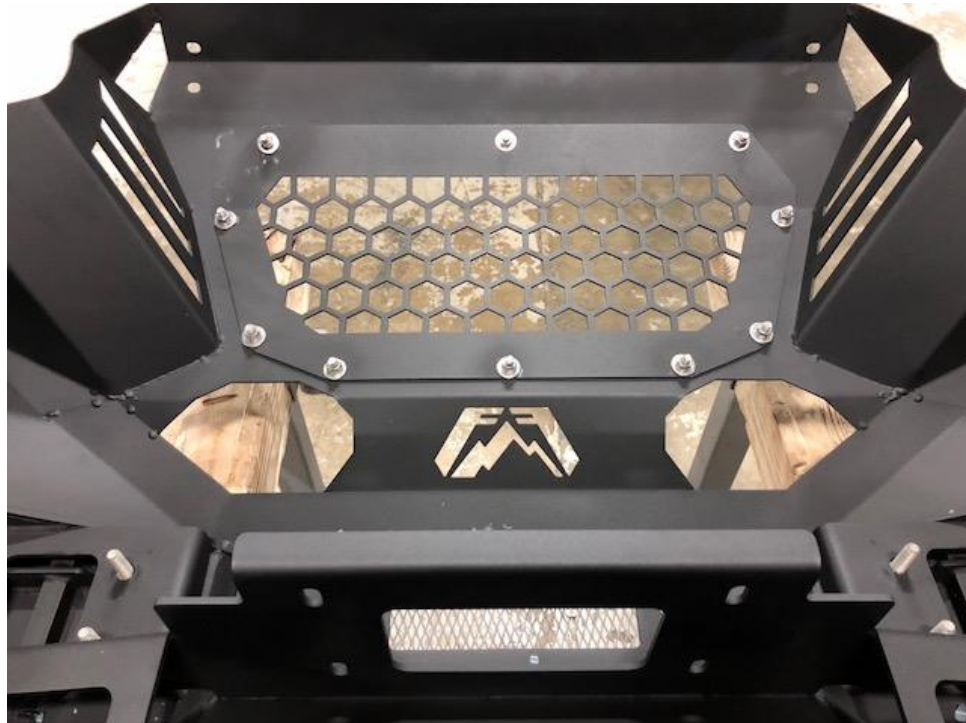



## Installation Instructions

### Jeep JL Front Grumper

Product Number: GR4600

Application: '18+ JEEP JL

**If installing winch, measure from the bolt hole to the farthest point on the winch (see below). If your winch is larger than 6.75” (for reference WARN Zeon series is 7.14”), you have following 2 options:**

#### **Option A**

**Insert the winch into the grumper shell but do not bolt down. Then when installing the winch it will take 3 people to install one on each side of the grumper and one manipulating the winch by turning it in while the grumper is being slid in. then bolt down the winch after the grumper is tightened down.**

**OR**

#### **Option B**

**Trim the frame flange buy how much you winch is over 6.75” to allow the winch to slide between the frame flanges.**





## Installation Instructions

### Jeep JL Front Grumper

Product Number: GR4600

Application: '18+ JEEP JL

**If you winch is smaller than 6.75" then just follow the instructions provided with winch. Remember to install fairlead onto front of Grumper.**

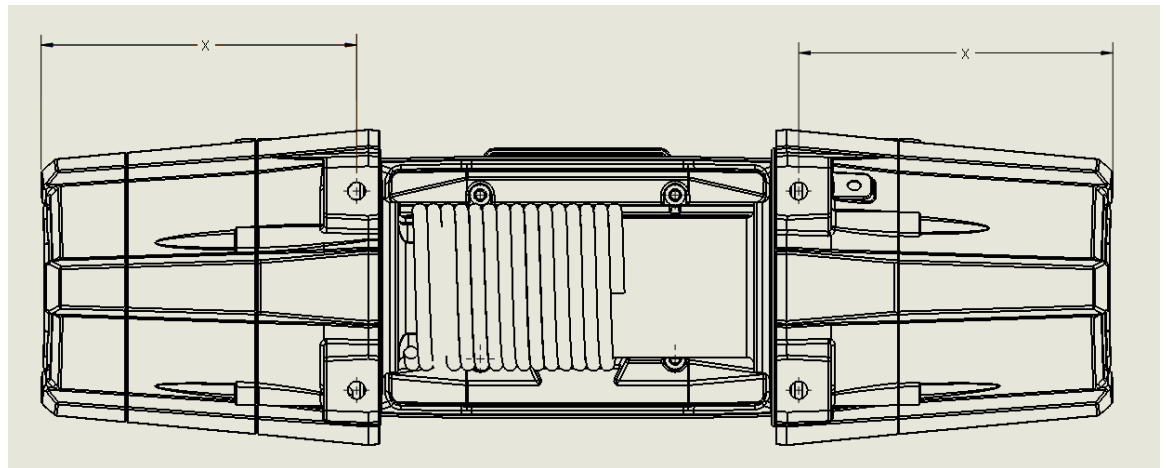



## Installation Instructions

### Jeep JL Front Grumper

Product Number: GR4600

Application: '18+ JEEP JL

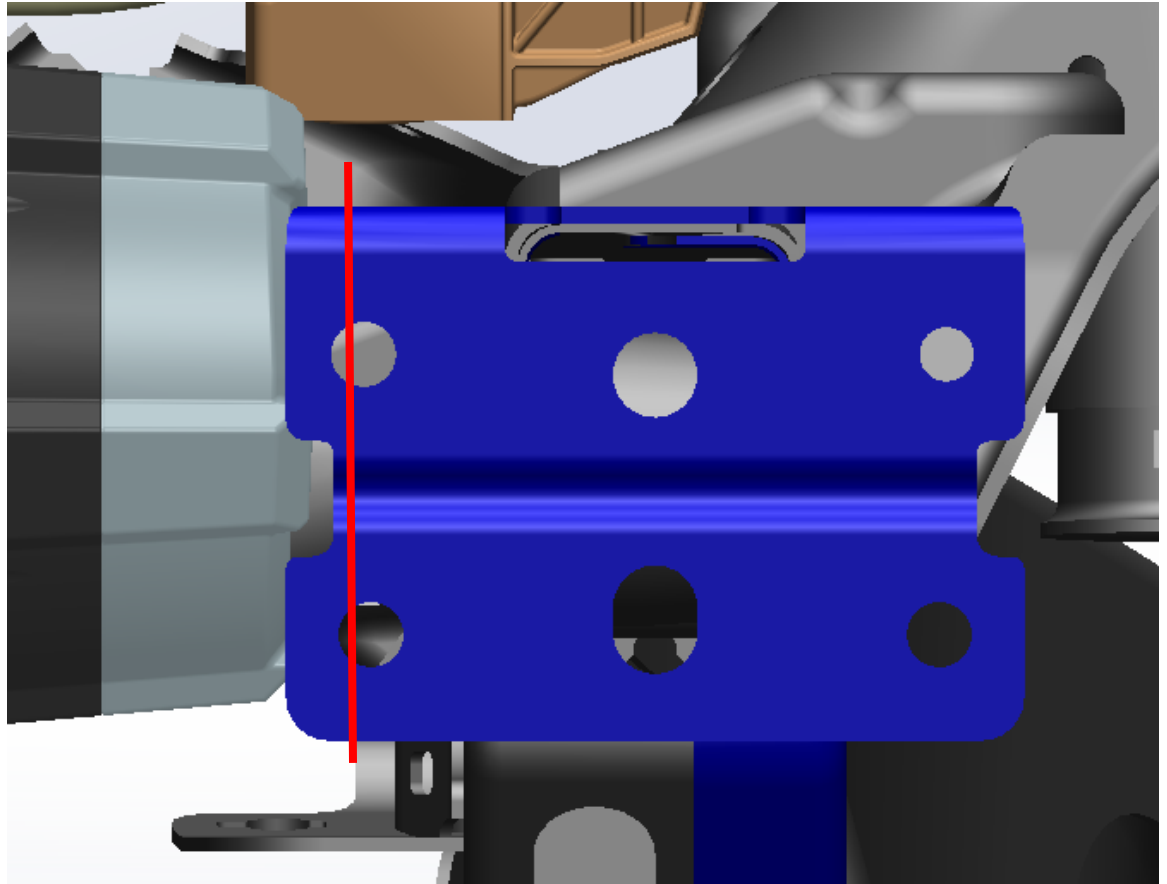

7. At this point if you are installing GR4605 (Grumper End Caps) then install now using the hardware provided with GR4605.





## Installation Instructions

### Jeep JL Front Grumper

Product Number: GR4600

Application: '18+ JEEP JL

#### Grumper Installation

1. Lift Grumper and align mounting studs with holes in frame face plate.
2. Secure loosely with supplied 7/16" flat washers, lock washer and nut. Do not tighten fully.
3. Because of the mounting system, little adjustment is necessary. Verify proper alignment and tighten all fasteners.

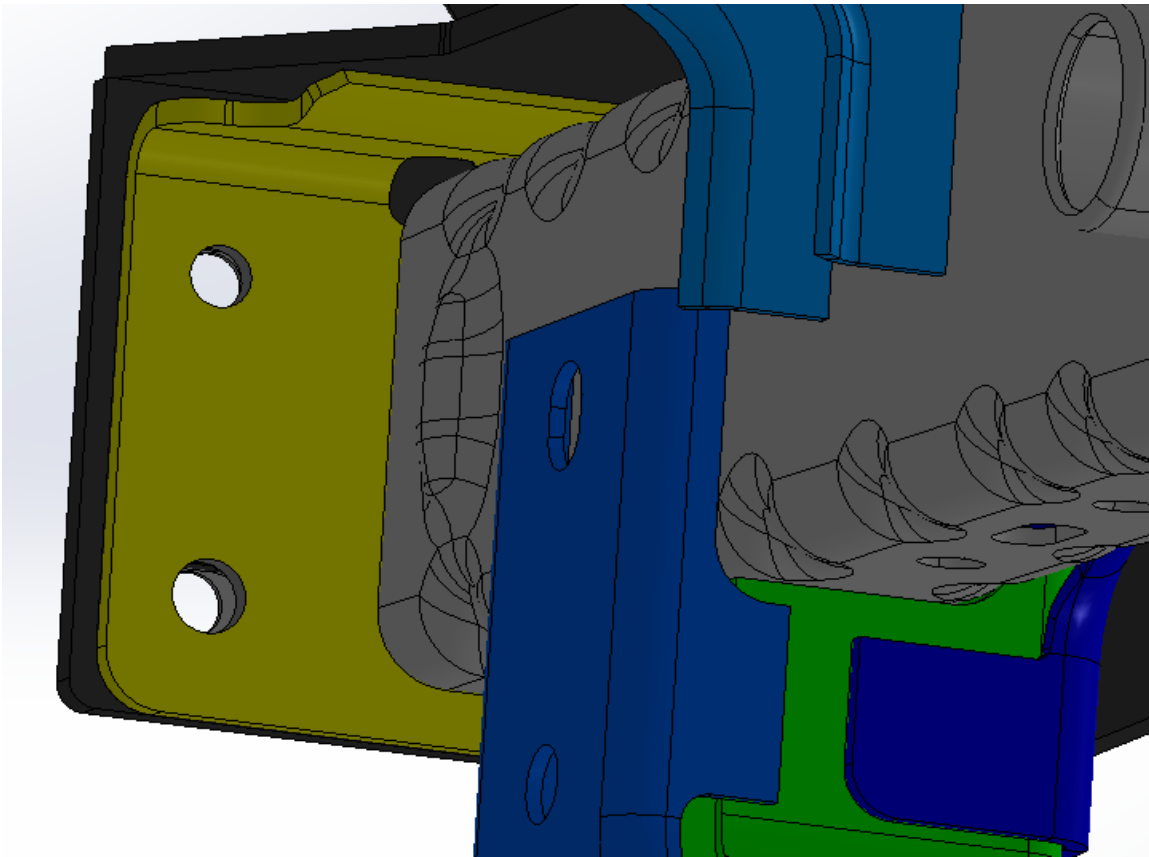

Figure 9 (inside view of frame)





## Installation Instructions

### Jeep JL Front Grumper

Product Number: GR4600

Application: '18+ JEEP JL

#### VI. Maintenance/Care

- Periodically check and tighten all fasteners.
- Stripped, fractured, or bent bolts or nuts need to be replaced.

#### VII. Contact Information

Fab Fours Inc.  
2213 Industrial Park Rd.  
Lancaster, SC 29720

Phone (866)-385-1905  
Fax (866)-574-1424  
Email [Support@fabfours.com](mailto:Support@fabfours.com)



More than expected... Better than expected

