

## CONTACT

### EMAIL:

info@ranchhand.com

### PHONE:

1.800.366.9712

### ADDRESS:

959 State Hwy 95 N  
Shiner, TX 77984



**RANCH HAND**  
PROTECT YOUR TRUCK

## MAINTENANCE/CARE

- Periodically check and tighten all fasteners.
- Stripped, fractured, or bent bolts or nuts need to be replaced.
- After washing of the vehicle make sure to fully dry all surfaces

## SENSOR DISCLAIMER

PLEASE NOTE PARKING SENSORS ARE EXTREMELY DELICATE AND MUST BE HANDLED WITH CARE!

Do NOT touch or shift the clear rubber grommet that surrounds the sensor face. DO NOT glue housing into place until orientation and functionality is determined.

## APPENDIX

### Troubleshooting Vehicle Sensors

- Start with a general inspection of the sensor fitment. Check that both the sensors and the sensor clips are fully secure and the sensors are properly centered in the housing.
- Confirm plastic housing is in the correct mounting holes. Misplaced sensor housings could compress sensor and give false readings or faults.
- Use a clean microfiber to wipe the front face of the sensor.
- Inspect connection. Be sure that the sensor is firmly seated into the harness.
- Run through several start cycles (i.e. fully turn the vehicle on and off).
- Finally, disconnect the battery to reset the sensors.

## WARNING

*If your vehicle has adaptive cruise, please ensure that your adaptive cruise is working correctly once the Ranch Hand bumper is installed. Adaptive cruise may need to be cleaned or adjusted to ensure it functions properly. See your owner's manual for care of the adaptive cruise.*

Special care should be exercised in the handling, storage and installation of Kaspar Ranch Hand equipment. The actual weight of each piece of equipment will vary depending on style and model. The weight of the equipment is sufficient in volume to warrant special care, assistance and in some instances, the use of mechanical equipment during the transfer and installation of the equipment. Do not assume a position directly under the equipment during installation. Be sure the equipment has been connected and stabilized during installation to prevent falling or shifting of positions. Periodically check tightness of bolts to make sure they are tight, and unlikely to fail.

## SAFETY

- In order to help you make informed decisions about safety, we have provided installation instructions and other information.
- These instructions alert you to potential injury hazards
- Please do a job safety analysis before each task to identify potential hazards for your situation and remove/protect against them.
- You must use your own good judgment.
- Read and understand all safety precautions and instructions before installing this product

## HAZARD

**FAILURE TO OBSERVE THESE INSTRUCTIONS COULD LEAD TO SEVERE INJURY OR DEATH.**

- Always remove jewelry and wear eye protection.
- Always use extreme caution when jacking up a vehicle for work. Set emergency brake and use tire blocks. Locate and use the vehicle manufacturers designated lifting points. Use jack stands.
- Always use appropriate and adequate care in lifting components into place.
- Always insure components will remain secure during installation and operation.
- Always wear safety glasses when installing this kit. A drilling operation will cause flying metal chips. Flying chips can cause serious eye injury.
- Always use extreme caution when drilling on a vehicle. Thoroughly inspect the area to be drilled (on both sides of material) prior to drilling, and relocate any objects that may be damaged.
- Always use extreme caution when cutting and trimming during fitting.
- Always tighten all nuts and bolts securely per installation instructions.
- Always route electrical cables carefully. Avoid moving parts, components that become hot and rough or sharp edges.
- Always insulate and protect all exposed wiring and electrical terminals.
- Always perform regular inspections and maintenance on mounts and related hardware.



**RANCH HAND**  
PROTECT YOUR TRUCK

# INSTALLATION INSTRUCTIONS

### DESCRIPTION

03-07 (Classic) GMC 2500HD  
& 3500 Pickup/03-07 (Classic)  
GMC 1500HD & 2500 Pickup  
Legend Grille Guard

### PART #:

GGG03IBL1/GGG03TBL1

## INSTALLATION INSTRUCTIONS:

1. Open hood and remove plastic cover. Then remove grille. (Note: you can mount top brackets from underneath the bumper.)
2. There is a driver and passenger side top bracket. They should measure 3 3/4" in height. Remove factory bumper top bolts and install brackets.
3. If the plastic cover and grille were removed, reinstall at this time.
4. Remove tow hooks if present. They will be relocated. (See tow hook mounting instructions)
5. On some trucks without tow hooks, you may have to cut an opening in the bottom plastic of the bumper.
6. Slide the legs of the grille guard into the frame.
7. Place 1/2" bolt through the leg of the grille guard and through the side of the frame. Place a second bolt, from the inside of the frame, through the bottom angle bracket of the grille guard and the bottom of the frame. (Note: It helps to use a thin piece of wire to fish the bolt through the frame.)
8. Bolt the tabs of the grille guard to the top mounting brackets. Place bolt from bottom facing up.
9. Make sure nuts and bolts are tight!!

## 03-07 (Classic) GMC 2500HD & 3500 Pickup/03-07 (Classic) GMC 1500HD & 2500 Legend Grille Guard GGG031BL1/GGG03TBL1

### TOOLS REQUIRED

Metric and SAE sockets

### PARTS LIST

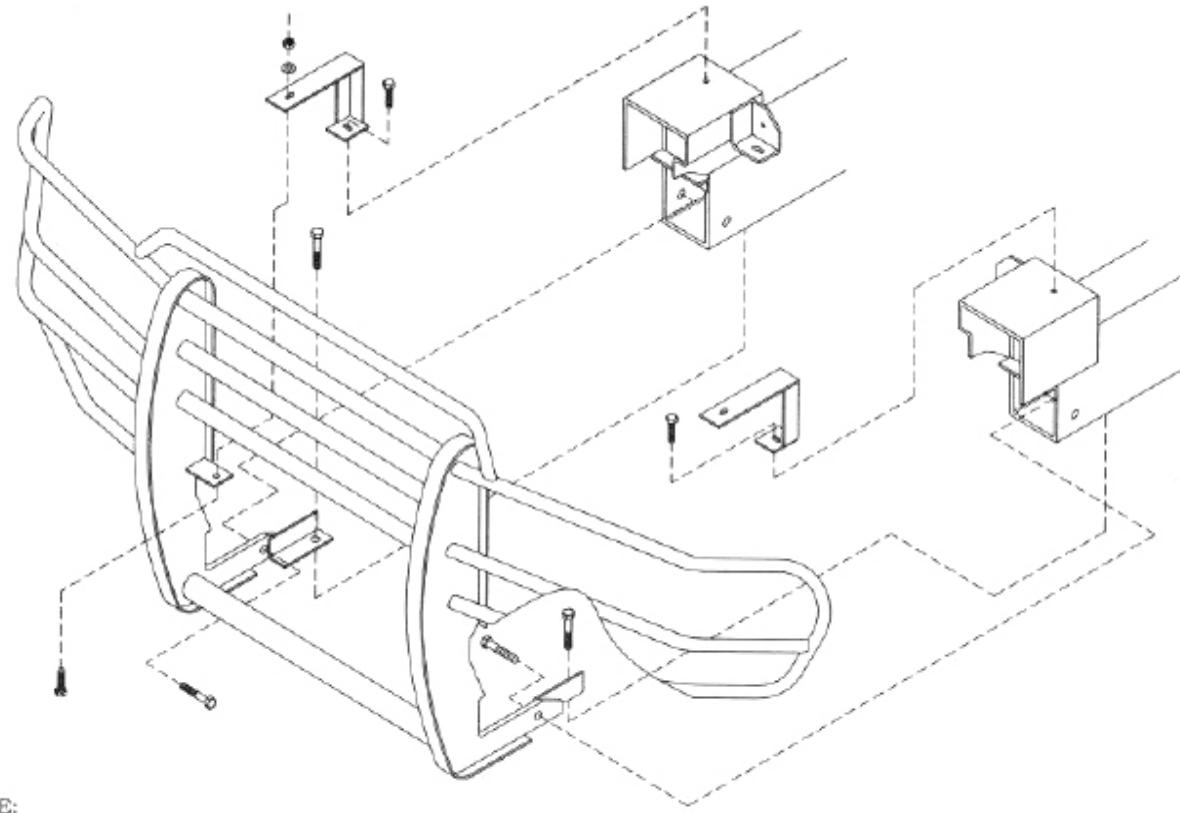

NOTE:  
-GRILL GUARD SHOWN FOR  
ILLUSTRATION PURPOSES ONLY.  
-TOP BRACKETS MAY VARY ACCORDING  
TO APPLICATION OF VEHICLE.