

CONTACT

EMAIL:

info@ranchhand.com

PHONE:

1.800.366.9712

ADDRESS:

959 State Hwy 95 N
Shiner, TX 77984



RANCH HAND
PROTECT YOUR TRUCK

MAINTENANCE/CARE

- Periodically check and tighten all fasteners.
- Stripped, fractured, or bent bolts or nuts need to be replaced.
- After washing of the vehicle make sure to fully dry all surfaces

SENSOR DISCLAIMER

PLEASE NOTE PARKING SENSORS ARE EXTREMELY DELICATE AND MUST BE HANDLED WITH CARE!

Do NOT touch or shift the clear rubber grommet that surrounds the sensor face. DO NOT glue housing into place until orientation and functionality is determined.

APPENDIX

Troubleshooting Vehicle Sensors

- Start with a general inspection of the sensor fitment. Check that both the sensors and the sensor clips are fully secure and the sensors are properly centered in the housing.
- Confirm plastic housing is in the correct mounting holes. Misplaced sensor housings could compress sensor and give false readings or faults.
- Use a clean microfiber to wipe the front face of the sensor.
- Inspect connection. Be sure that the sensor is firmly seated into the harness.
- Run through several start cycles (i.e. fully turn the vehicle on and off).
- Finally, disconnect the battery to reset the sensors.

WARNING

If your vehicle has adaptive cruise, please ensure that your adaptive cruise is working correctly once the Ranch Hand bumper is installed. Adaptive cruise may need to be cleaned or adjusted to ensure it functions properly. See your owner's manual for care of the adaptive cruise.

Special care should be exercised in the handling, storage and installation of Kaspar Ranch Hand equipment. The actual weight of each piece of equipment will vary depending on style and model. The weight of the equipment is sufficient in volume to warrant special care, assistance and in some instances, the use of mechanical equipment during the transfer and installation of the equipment. Do not assume a position directly under the equipment during installation. Be sure the equipment has been connected and stabilized during installation to prevent falling or shifting of positions. Periodically check tightness of bolts to make sure they are tight, and unlikely to fail.

SAFETY

- In order to help you make informed decisions about safety, we have provided installation instructions and other information.
- These instructions alert you to potential injury hazards
- Please do a job safety analysis before each task to identify potential hazards for your situation and remove/protect against them.
- You must use your own good judgment.
- Read and understand all safety precautions and instructions before installing this product

HAZARD

FAILURE TO OBSERVE THESE INSTRUCTIONS COULD LEAD TO SEVERE INJURY OR DEATH.

- Always remove jewelry and wear eye protection.
- Always use extreme caution when jacking up a vehicle for work. Set emergency brake and use tire blocks. Locate and use the vehicle manufacturers designated lifting points. Use jack stands.
- Always use appropriate and adequate care in lifting components into place.
- Always insure components will remain secure during installation and operation.
- Always wear safety glasses when installing this kit. A drilling operation will cause flying metal chips. Flying chips can cause serious eye injury.
- Always use extreme caution when drilling on a vehicle. Thoroughly inspect the area to be drilled (on both sides of material) prior to drilling, and relocate any objects that may be damaged.
- Always use extreme caution when cutting and trimming during fitting.
- Always tighten all nuts and bolts securely per installation instructions.
- Always route electrical cables carefully. Avoid moving parts, components that become hot and rough or sharp edges.
- Always insulate and protect all exposed wiring and electrical terminals.
- Always perform regular inspections and maintenance on mounts and related hardware.



RANCH HAND
PROTECT YOUR TRUCK

INSTALLATION INSTRUCTIONS

DESCRIPTION

2009 Ford F-150
Legend Grille Guard

PART #:

GGF09HBL1

INSTALLATION INSTRUCTIONS:

2009 Ford F-150 Legend Grille Guard

GGF09HBL1

TOOLS REQUIRED

Metric and SAE sockets

PARTS LIST

4X4 MODELS

1. Remove the factory tow hooks. Leave factory nuts in the frame.
2. Mount the bottom brackets of the grille guard to the bottom of the frame and then the tow hooks. Use the factory bolts to install.
3. Center from side to side and tighten bolts.
4. Mount the top bracket to the tab that is welded to the pipe. Use the black carriage bolts to install. Leave loose. Line up the other end of the bracket with the hole in the bumper.
5. Use the 3/4" x 5 1/2" bolt to mount the support bracket to the side of the frame. Place the bolt from inside facing out. The other end will match up with the top bracket. Use the black carriage bolts to install.
6. Once all bolts and brackets are installed, tighten all nuts and bolts except the carriage bolts to the tabs.
7. Push the top of the grille guard towards the truck until the loops line up with the headlights and tighten bolts.

4x2 MODELS

1. You will have to cut a 4" wide x 6 1/2" long slot in the air dam in order to install this grille guard.
2. Use the template to help with the location. The template is a setup for the passenger side. Flip the template over for the driver side. After cutting the template out, line the side edge of the template with the metal part of the bumper and the top of the template with the bottom of the rectangular plastic bumper insert.
3. The cut will start 4 1/2" over from the metal part of the bumper and will end at 8 1/2". It will start 1/2" down from the plastic rectangular bumper insert and extend down to 7". Trim as needed.
4. On the bottom of each frame rail, there will be two holes. Slide the hex nut tab into the frame over these holes.
5. Mount the bottom brackets of the grille guard to the bottom of the frame.
6. Center from side to side and tighten bolts.
7. Mount the top bracket to the tab that is welded to the pipe. Use the black carriage bolts to install. Leave loose. Line up the other end of the bracket with the hole in the bumper.
8. Use the 3/4" x 5 1/2" bolt to mount the support bracket to the side of the frame. Place the bolt from inside facing out. The other end will match up with the top bracket. Use the black carriage bolts to install.
9. Once all bolts and brackets are installed, tighten all nuts and bolts except the carriage bolts to the tabs. Push the top of the grille guard towards the truck until the loops line up with the headlights and tighten bolts.
10. Push the top of the grille guard towards the truck until the loops line up with the headlights and tighten bolts.

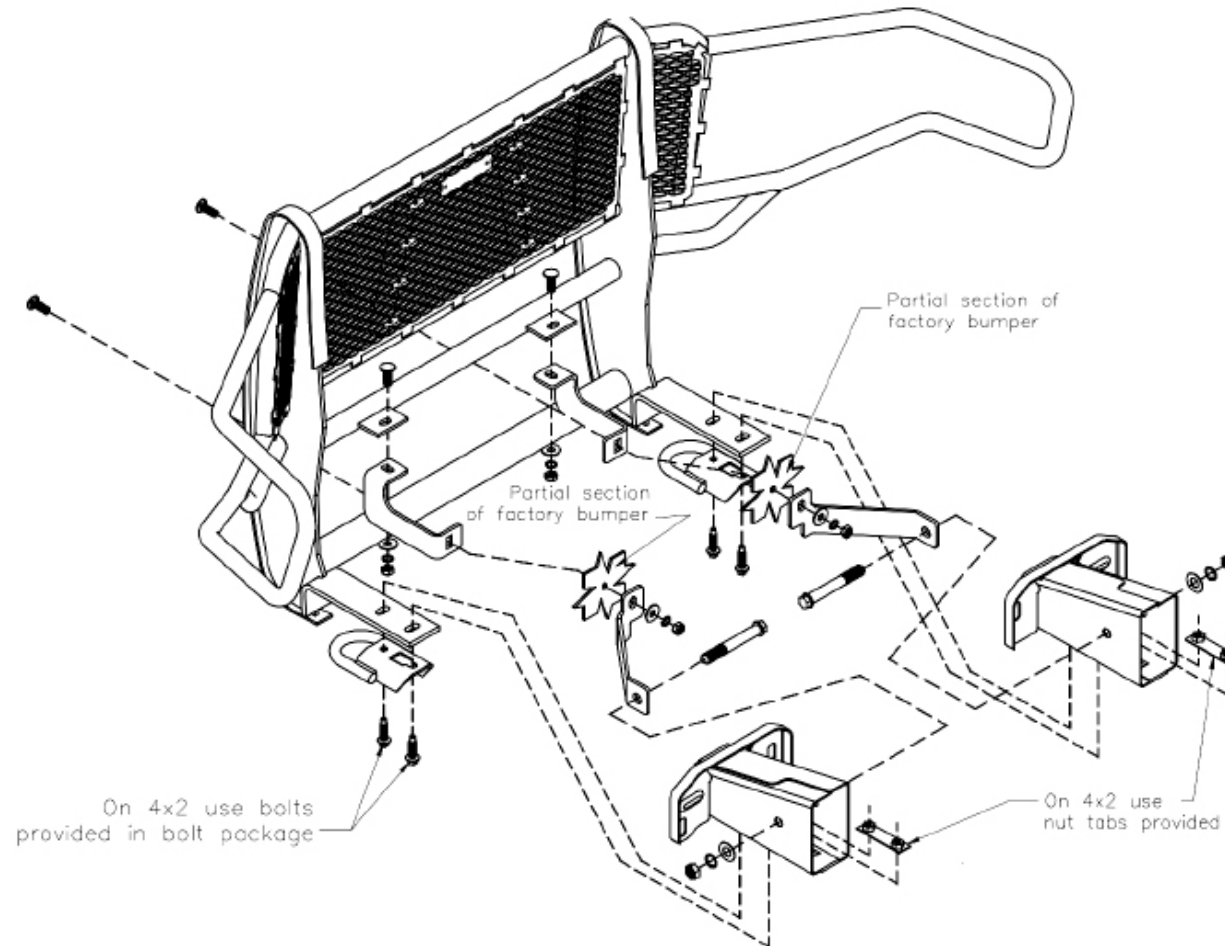

CUT

Passenger Side

09 Ford F-150
4x2

CUT
OUT

CUT

