



1.877.287.8634

INSTALLATION INSTRUCTIONS

IMPORTANT NOTICE: Be sure to inspect and test fit product before having it coated or painted. Ranch Hand will not be responsible for the cost of the coating if any problems with fit or finish are not noted and addressed beforehand.

**2021-up FORD F-150 SUMMIT FRONT BUMPERS
FSF21HBL1 / FSF21HBL1C / BSF21HBL1**

Note: You will lose the motorized air dam on this installation.

1. Before removing the bumper, you will need to locate and disconnect the main harness connector and connector for the bottom louvers. Both are located on the passenger side.



2. To remove the factory bumper, you will need to remove the six 21mm mounting nuts (three on each frame horn). There will be one more connector above the bottom louver system on the driver side. Carefully pull the bumper away from the frame then unplug connector.



3. If tow hooks are present, remove them. Mount the bottom brackets along with the tow hooks to the bottom of the frame. Mount the top brackets to the two outside holes in the frame plate. Use 1/2" hardware provided. Brackets should be about 39 1/2" O.D. apart. (Hand tighten)

----- **WARNING** -----

Special care should be exercised in the handling, storage and installation of Ranch Hand equipment. The actual weight of each piece of equipment will vary depending on style and model. The weight of the equipment is sufficient in volume to warrant special care, assistance and in some instances, the use of mechanical equipment during the transfer and installation of the equipment. Do not assume a position directly under the equipment during installation. Be sure the equipment has been connected and stabilized during installation to prevent falling or shifting of positions. Periodically check tightness of bolts to make sure they are tight, and unlikely to fail.



1.877.287.8634

INSTALLATION INSTRUCTIONS

IMPORTANT NOTICE: Be sure to inspect and test fit product before having it coated or painted. Ranch Hand will not be responsible for the cost of the coating if any problems with fit or finish are not noted and addressed beforehand.



4. Remove the wiring harness from the factory bumper. Also remove fog lights and adaptive cruise if present.
5. If your vehicle has sensors remove the “knock-outs” from the bumper. Install the rubber grommets and then install the sensors.
6. Install the fog lights, if present, following the LBF21HBP instructions.
7. If Adaptive Cruise Control is present remove from factory bumper. Install it to the provided bracket and hardware. Mount the assembly to the angle iron located on the bottom side of the top plate.

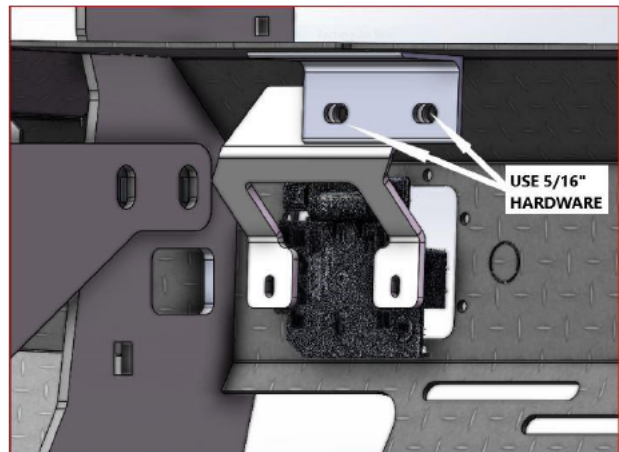
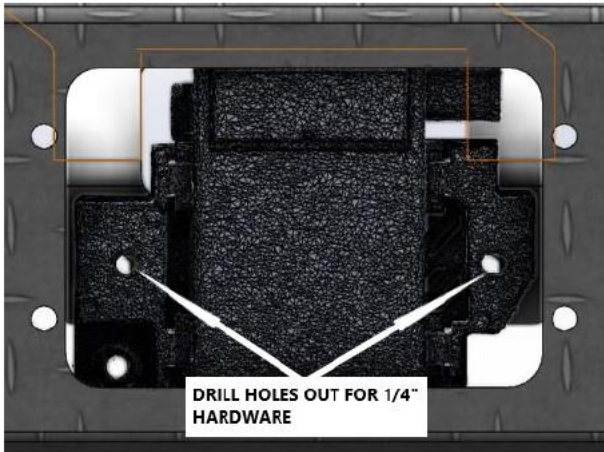

8. Install the center inserts by using the black button head bolts, nuts, and rubber washers. **NOTE: IF THE ADAPTIVE CRUISE DOES NOT FUNCTION PROPERLY, REMOVE THE INSERT FROM IN FRONT OF THE MODULE AND RETEST.**
9. Once fog lights, sensors and adaptive cruise is installed, mount the bumper to the bumper brackets. Use provided carriage bolts to install. Once bumper is in the proper position, tighten all nuts and bolts. Make sure all plugs are connected.
10. **MAKE SURE ALL NUTS AND BOLTS ARE TIGHT!**

----- WARNING -----

Special care should be exercised in the handling, storage and installation of Ranch Hand equipment.

The actual weight of each piece of equipment will vary depending on style and model. The weight of the equipment is sufficient in volume to warrant special care, assistance and in some instances, the use of mechanical equipment during the transfer and installation of the equipment.

Do not assume a position directly under the equipment during installation. Be sure the equipment has been connected and stabilized during installation to prevent falling or shifting of positions.

Periodically check tightness of bolts to make sure they are tight, and unlikely to fail.

Rev. 2023