



1-877-287-8634

INSTALLATION INSTRUCTIONS

IMPORTANT NOTICE: Be sure to inspect and test fit product before having it coated or painted. Ranch Hand will not be responsible for the cost of the coating if any problems with fit or finish are not noted and addressed beforehand.

2017-up FORD SUPER DUTY LEGEND BACK BUMPER PART # BBF231BLSS

TOOLS REQUIRED

- Ratchet and extension
- 7/16", 3/4", (15/16" or 24mm) sockets & wrenches
- 13, 15, 21 and 24mm sockets & wrenches
- Flat and/or Phillips screwdriver
- Hammer
- Chisel or Punch
- Cutting pliers
- Butt connectors



1. Disconnect the factory trailer plug.
2. Disconnect the license plate light/sensor wiring harness. It is located to the right of the spare tire guide tube.

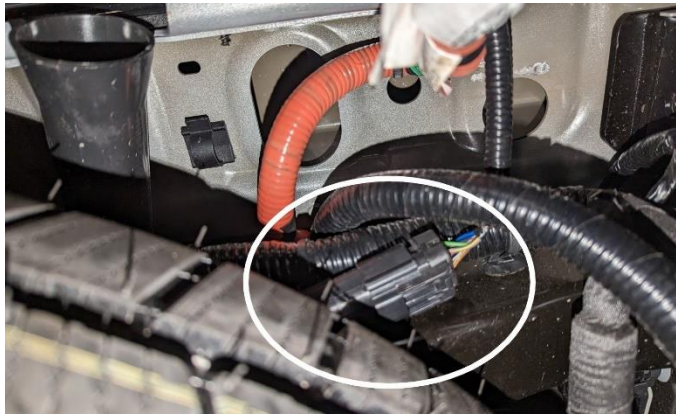

3. Remove the factory bumper by removing the four 21mm nuts located behind the bumper. (Two on each side) Also, remove the two 13mm bolts located near the receiver hitch.

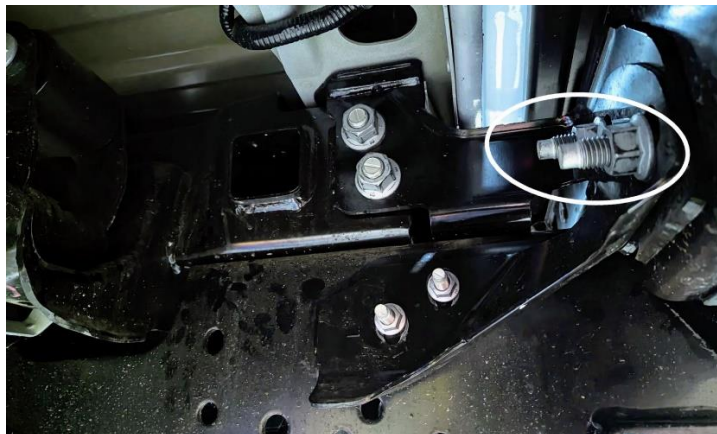

----- WARNING -----

Special care should be exercised in the handling, storage and installation of Ranch Hand equipment. The actual weight of each piece of equipment will vary depending on style and model. The weight of the equipment is sufficient in volume to warrant special care, assistance and in some instances, the use of mechanical equipment during the transfer and installation of the equipment. Do not assume a position directly under the equipment during installation. Be sure the equipment has been connected and stabilized during installation to prevent falling or shifting of positions. Periodically check tightness of bolts to make sure they are tight, and unlikely to fail.
Rev. 2023



1-877-287-8634

INSTALLATION INSTRUCTIONS

IMPORTANT NOTICE: Be sure to inspect and test fit product before having it coated or painted. Ranch Hand will not be responsible for the cost of the coating if any problems with fit or finish are not noted and addressed beforehand.

4. Unplug the factory license plate lights.
5. If sensors are present, remove sensors from bumper.
6. (2017-22 models) Remove the bumper brackets from the frame. There will be four 21mm nuts and bolts on each side.

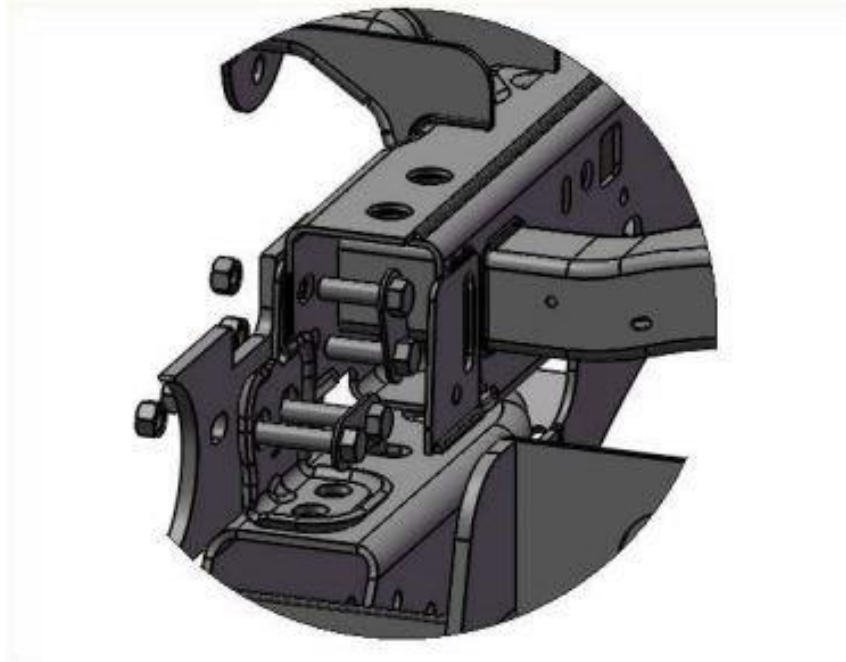

7. (2023 models) Remove the bumper bracket by removing the two 21mm bolts and two 15mm bolts from each side. Also, remove the one 24mm (15/16") bolt from top of the frame.



8. (2017-22) Install the Ranch Hand bumper. Reuse the factory 21mm nuts and bolts to mount.

----- **WARNING** -----

Special care should be exercised in the handling, storage and installation of Ranch Hand equipment. The actual weight of each piece of equipment will vary depending on style and model. The weight of the equipment is sufficient in volume to warrant special care, assistance and in some instances, the use of mechanical equipment during the transfer and installation of the equipment. Do not assume a position directly under the equipment during installation. Be sure the equipment has been connected and stabilized during installation to prevent falling or shifting of positions. Periodically check tightness of bolts to make sure they are tight, and unlikely to fail.
Rev. 2023



1-877-287-8634

INSTALLATION INSTRUCTIONS

IMPORTANT NOTICE: Be sure to inspect and test fit product before having it coated or painted. Ranch Hand will not be responsible for the cost of the coating if any problems with fit or finish are not noted and addressed beforehand.

- (2023-up) Install the angle brackets by reusing the 24mm bolts and nut tab. Also, use a 1/2" bolt in the second hole of the angle bracket and nut tab. Use two washers as spacers between the frame and nut tab. Line up the angle bracket with the side of the frame.



- Set up one of the bolt tabs inside the frame so it is inline with the holes of the frame. May need to prop it up with a block. Makes it easier to install.



- (2017-22) Install the bumper by reusing the factory bolt tabs and nuts. (2023-up) Use factory bolt tab and nuts for the front holes and use 1/2" hardware for back to holes.
- Install the trailer plug. **Note:** Use a flat screwdriver to spread the prongs open to help secure the trailer plug.
- If sensors are present, remove the "knock-out" plugs by using a hammer and chisel or punch. Install the rubber grommets into the sensor holes.
- Install the license plate with the four 1/4" bolts.
- Install the license plate light and wire to the same wires as the factory license plate wires.
- MAKE SURE ALL NUTS AND BOLTS ARE TIGHT!**

----- **WARNING** -----

Special care should be exercised in the handling, storage and installation of Ranch Hand equipment. The actual weight of each piece of equipment will vary depending on style and model. The weight of the equipment is sufficient in volume to warrant special care, assistance and in some instances, the use of mechanical equipment during the transfer and installation of the equipment. Do not assume a position directly under the equipment during installation. Be sure the equipment has been connected and stabilized during installation to prevent falling or shifting of positions. Periodically check tightness of bolts to make sure they are tight, and unlikely to fail.
Rev. 2023