

**ELEVATION BULL NOSE FRONT BUMPER
2015-17 CHEVY COLORADO**

PARTS LIST:

1	Elevation Bull Nose Front Bumper Assembly	16	12mm Nylon Lock Nuts
1	Winch Tray Assembly	4	10-1.5mm x 25mm Hex Bolts
1	Driver/left Frame Mounting Bracket	4	10mm x 30mm OD x 2.5mm Flat Washers
1	Passenger/right Frame Mounting Bracket	4	10mm Lock Washers
1	Driver/left "L" Bracket (center LED light)	2	8mm x 25mm Hex Bolts
1	Passenger/right "L" Bracket (center LED light)	2	8mm x 16mm Hex Bolts
1	Winch Access Cover	6	8mm x 24mm x 2mm Flat Washers
4	12-1.75mm x 100mm Hex Bolts	4	8mm Lock Washers
12	12-1.75mm x 40mm Hex Bolts	2	8mm Hex Nuts
24	12mm x 37mm x 3mm Large Flat Washers	5	6mm x 20mm Button Head Combo Bolts
8	12mm x 24mm x 2.5mm STD Flat Washers	1	4mm Wrench
		2	Plastic Plugs for License Plate

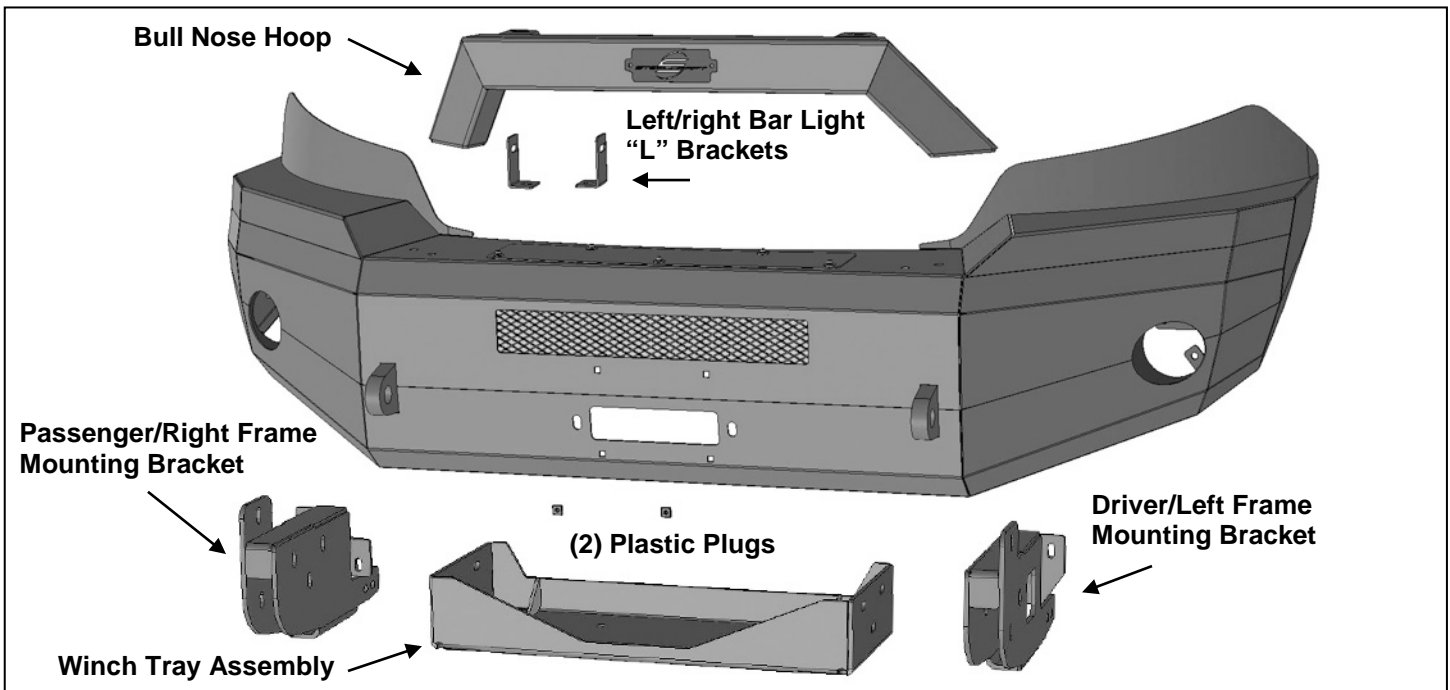

PROCEDURE:

REMOVE CONTENTS FROM BOX. VERIFY ALL PARTS ARE PRESENT. READ INSTRUCTIONS CAREFULLY BEFORE STARTING INSTALLATION. ASSISTANCE IS HIGHLY RECOMMENDED TO AVOID POSSIBLE INJURY OR DAMAGE TO THE VEHICLE.

1. Remove the license plate and bracket. Next, open the hood and remove the plastic cover from the top of the radiator and the grille, **(Figure 1)**. Remove the hardware attaching the top of the grille.
2. Move to below the front bumper and remove the hex bolts attaching the bottom of the bumper cover to the steel inner impact bumper, **(Figure 2)**. Next, locate the driver/left side plastic inner bumper reinforcement. Remove the hardware attaching the reinforcement to the end of the frame, **(Figure 3)**. Repeat to release the passenger/right side bumper reinforcement.
3. Move to the driver/left wheel opening and remove the (7) screws attaching the plastic fender liner to the fender, **(Figure 4)**. Carefully separate the fender liner from the fender. On models with factory fog lights, reach in through the opening between the liner and the fender and unplug the wiring harness leading to the light, **(Figure 5)**. Also unplug harness leading to bumper. Next, locate and remove the (3) screws attaching the end of the bumper cover to the front of the fender, **(Figure 6)**.
4. Repeat **Step 3** to remove the bumper cover hardware from the passenger/right side of the vehicle.
5. With assistance, gently pull the bumper cover with grille attached, outward and off the vehicle.
6. Separate the grille from the bumper cover, reinstall the grille and top cover, **(Figure 7)**.

**ELEVATION BULL NOSE FRONT BUMPER
2015-17 CHEVY COLORADO**

7. From the front, locate and remove the (2) hex bolts attaching the air deflector, **(Figure 7)**.
8. Next, remove the steel impact bumper from the ends of the frame, **(Figures 8 & 9)**.
9. Select the driver/left side Frame Mounting Bracket, **(Figure 10)**. Reuse (2) factory hex bolts to attach the Bracket to the end of the frame, **(Figures 10—12)**. Next, attach the rear mounting tabs on the Bracket to the tow hook mounting holes with the included (2) 12mm x 100mm Hex Bolts, (4) 12mm x 24mm STD Flat Washers and (2) 12mm Nylon Lock Nuts, **(Figure 10)**. Snug but do not fully tighten hardware at this time. Repeat to install the passenger/right Frame Mounting Bracket.
10. **Optional Winch Tray and Winch installation (winch sold separately):**
 - a. Select the Winch Tray. With assistance, slide the Winch Tray between the Frame Brackets. Attach the Winch Tray to the Frame Brackets with (6) 12mm x 40mm Hex Bolts, (12) 12mm x 37mm Large Flat Washers and (6) 12mm Nylon Lock Nuts, **(Figures 13 & 14)**. Snug but do not fully tighten all hardware. **IMPORTANT: LED bar style light cannot be installed with Winch Tray. If installation of LED bar style light is desired, do not install the Winch Tray and skip to Step 11.**
 - b. If installing winch, follow manufacturer's instructions to attach the winch to the Winch Tray. Winch must be installed before Bumper is placed in position against Brackets. Also attach winch cable guide, (not included), to Bumper assembly at this time.
11. **Optional Center LED light installation (sold separately). NOTE:** Light must be installed before Bumper Assembly is attached to the Frame Brackets. **IMPORTANT: Winch Tray cannot be installed with LED bar style light assembly.**
 - a. Select the L/R "L" Brackets, **(Figure 15)**. **NOTE:** "L" Brackets are offset for universal fitment for most LED bar style lights. Attach the LED light assembly to the "L" Brackets with the included (2) 8mm x 16mm Hex Bolts, (2) 8mm Lock Washers and (2) 8mm Flat Washers. Do not fully tighten hardware at this time. **NOTE:** "L" Brackets may require modification for hardware larger than 8mm or use brackets supplied with light if possible.
 - b. Attach the light and Brackets to the top of the (2) tabs on the back of the Bumper with the included 8mm x 25mm Hex Bolts, (4) 8mm Flat Washers, (2) 8mm Lock Washers and (2) 8mm Hex Nuts, **(Figure 15)**. Adjust light position and tighten hardware.
 - c. Follow light manufacturer's instructions to wire the light once Bumper has been fully installed.
12. **Optional "Bull Nose" bolt on Hoop.** Bull Nose Hoop must be installed before installing Bumper. Attach Bull Nose Hoop to top of Bumper with (4) 10mm Hex Bolts, (4) 10mm Lock Washers and (4) 10mm Flat Washers, **(Figure 16)**. Fully tighten 10mm hardware at this time only.
13. With assistance, position the Bumper Assembly up to the inside of the Frame Brackets. Temporarily support the weight of the Bumper. **WARNING:** To avoid possible injury or damage to the vehicle, do not proceed until the Bumper is fully and safely supported.
14. Line up the (3) holes in the driver/left side mounting plate on the back of the Bumper with the (3) slots in the Frame Bracket. Attach the Bumper to the Bracket with the included (3) 10mm x 35mm Hex Bolts, (6) 10mm Flat Washers, (3) 10mm Lock Washers and (3) 10mm Hex Nuts, **(Figures 17 & 18)**. Do not fully tighten hardware at this time. Repeat this **Step** to attach the passenger/right side of the Bumper.
15. Level and adjust the bumper and fully tighten all hardware.

Models with fog lights:

- a. Slide the light into place through the opening in the bumper. Push the attaching posts into the tabs on the bumper, **(Figures 19 & 20)**. Repeat this Step to install remaining light.
 - b. Reattach the factory wiring harness to both lights.
16. Use the included (2) push-in plastic nuts to attach the front license plate, (if required), to the (2) holes in the front bumper, **(Figure 21)**.
 17. Do periodic inspections to the installation to make sure that all hardware is secure and tight.

To protect your investment, wax this product after installing. Regular waxing is recommended to add a protective layer over the finish. Do not use any type of polish or wax that may contain abrasives that could damage the finish. Mild soap may be used to clean the Front Bumper assembly.

**ELEVATION BULL NOSE FRONT BUMPER
2015-17 CHEVY COLORADO**

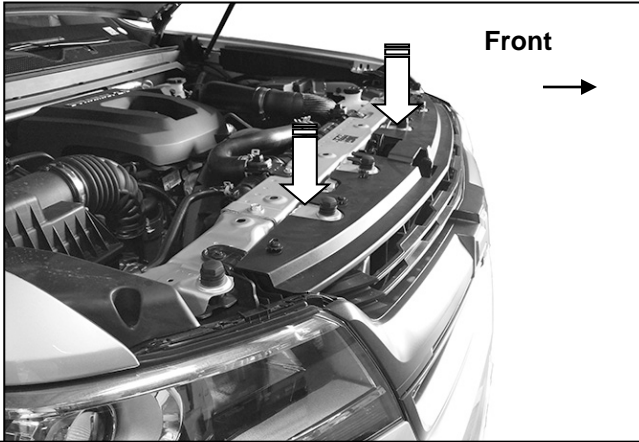

(Fig 1) Remove cover between radiator and grille. Remove screws attaching top of grille (arrows)

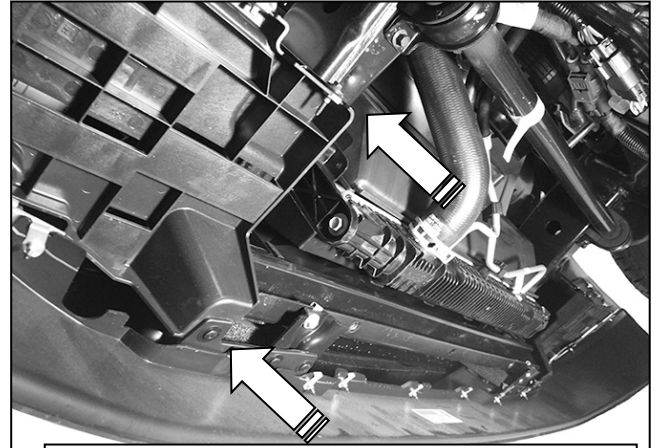

(Fig 2) Remove hardware attaching bumper cover to cross member behind bumper

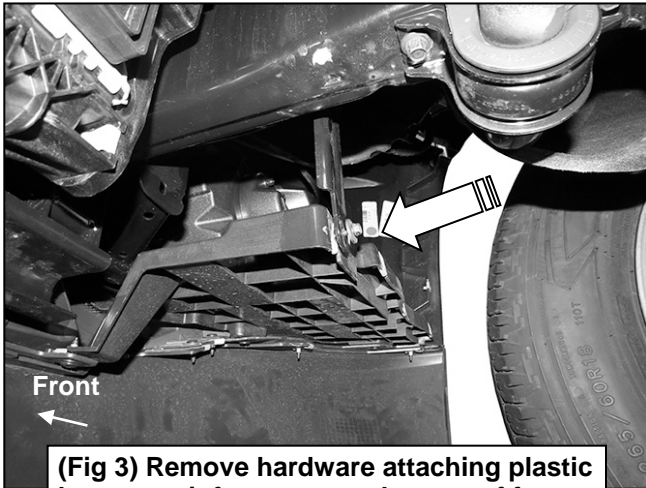

(Fig 3) Remove hardware attaching plastic bumper reinforcement to bottom of frame, (arrow - passenger side pictured)

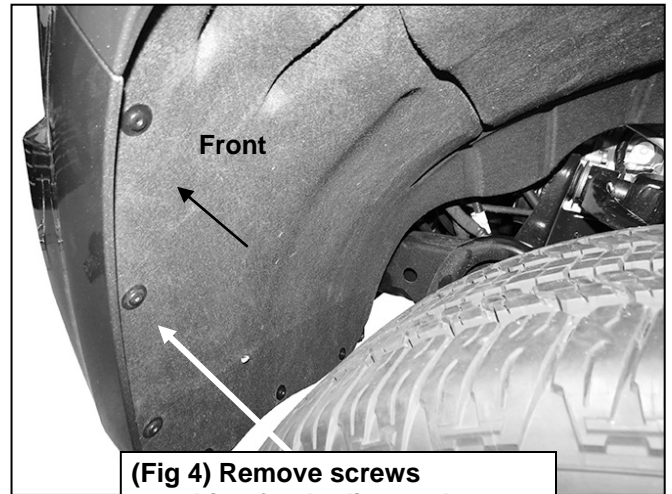

(Fig 4) Remove screws attaching fender liner to bumper

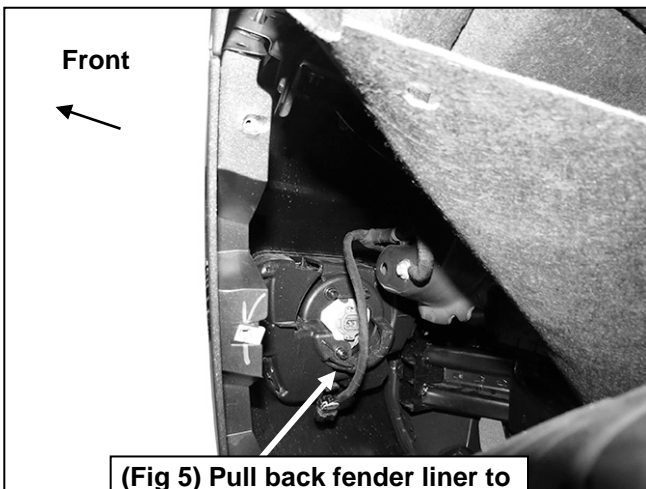

(Fig 5) Pull back fender liner to unplug fog light if equipped

**ELEVATION BULL NOSE FRONT BUMPER
2015-17 CHEVY COLORADO**

Driver/Left Side Installation Pictured

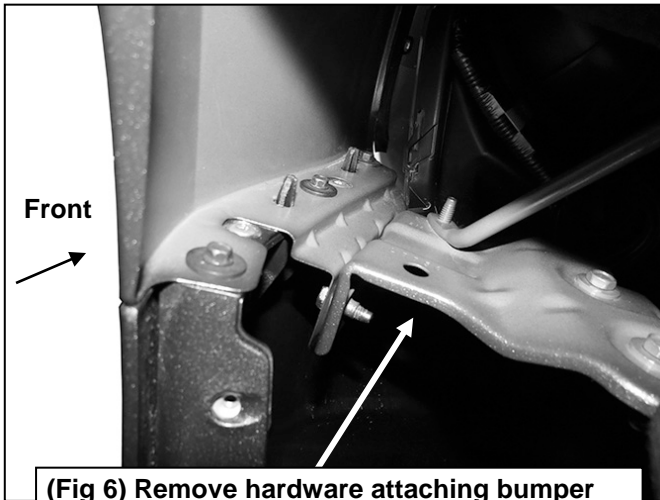

(Fig 6) Remove hardware attaching bumper cover to both fenders. Remove bumper cover

WARNING! Do not crawl under bumper unless the bumper is properly supported on blocks or stands or the bumper may fall.



(Fig 7) Remove (2) hex bolts (arrows) to remove air deflector

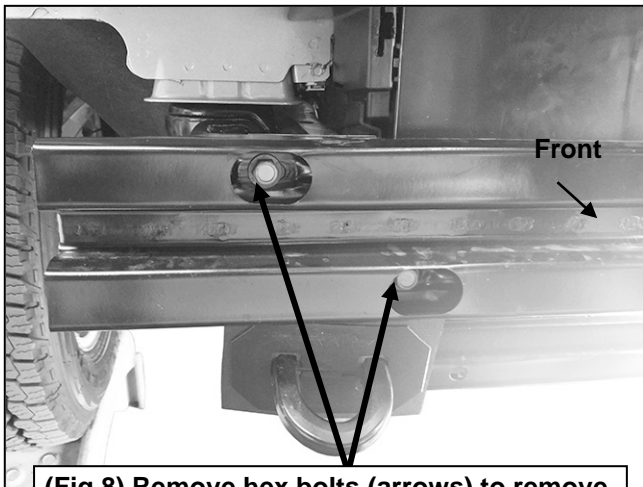

(Fig 8) Remove hex bolts (arrows) to remove impact bumper (passenger side pictured)

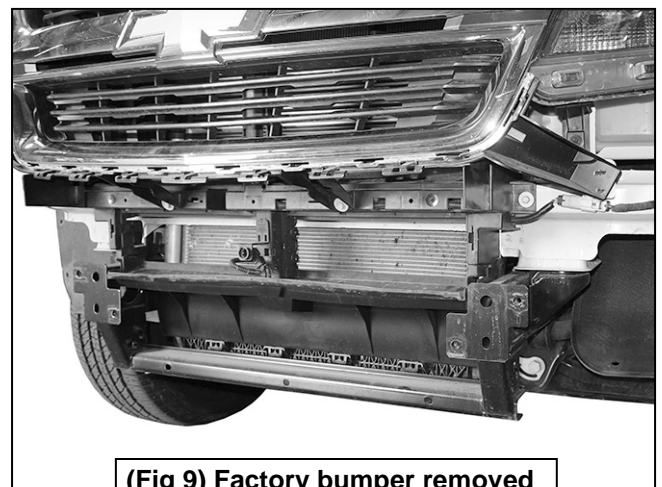

(Fig 9) Factory bumper removed

ELEVATION BULL NOSE FRONT BUMPER
2015-17 CHEVY COLORADO

Driver/Left Side Installation Pictured

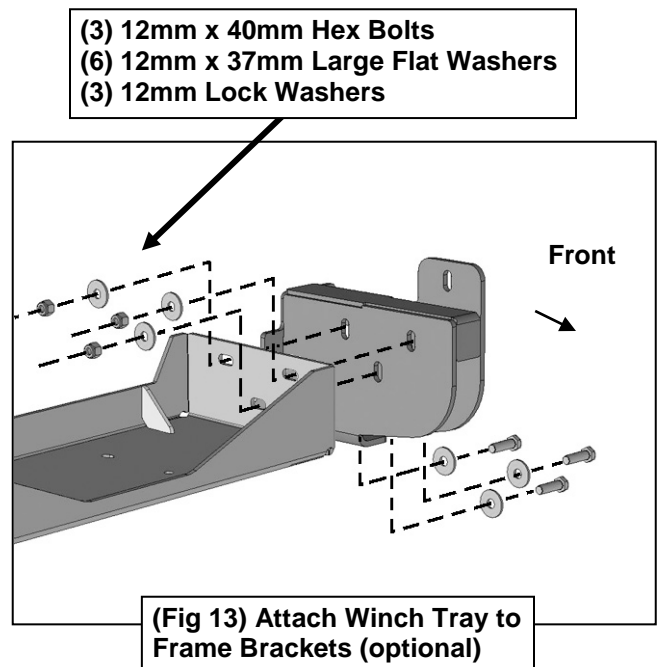
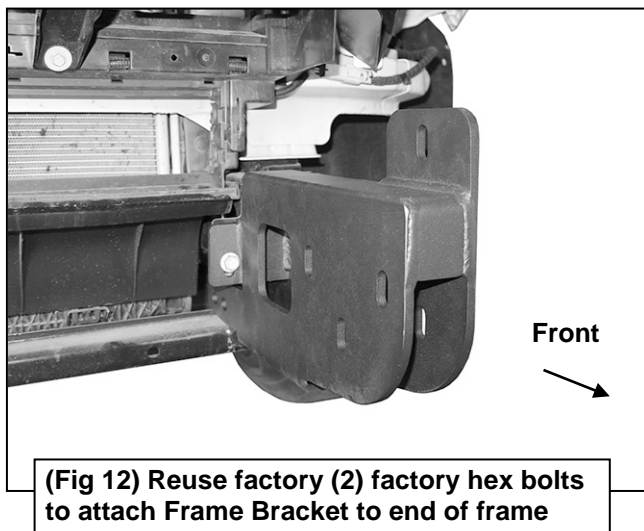
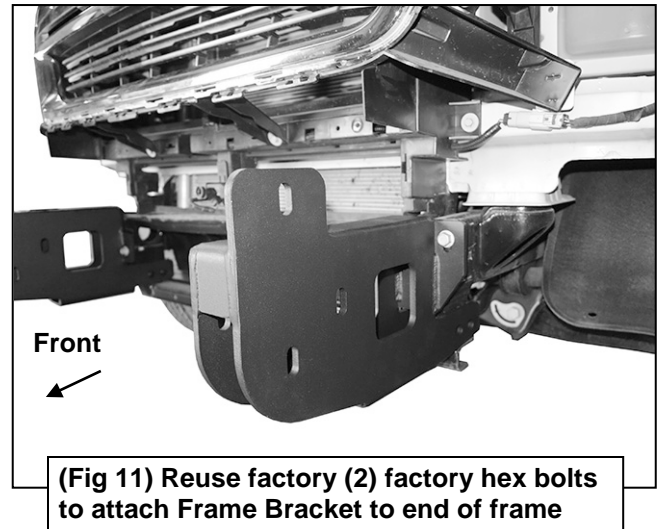
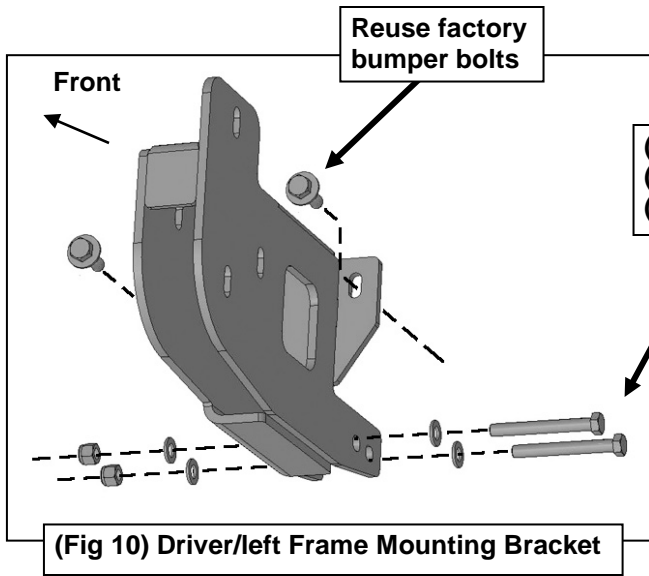

WARNING! Do not crawl under bumper unless the bumper is properly supported on blocks or stands or the bumper may fall.

ELEVATION BULL NOSE FRONT BUMPER
2015-17 CHEVY COLORADO

Driver/Left Side Installation Pictured

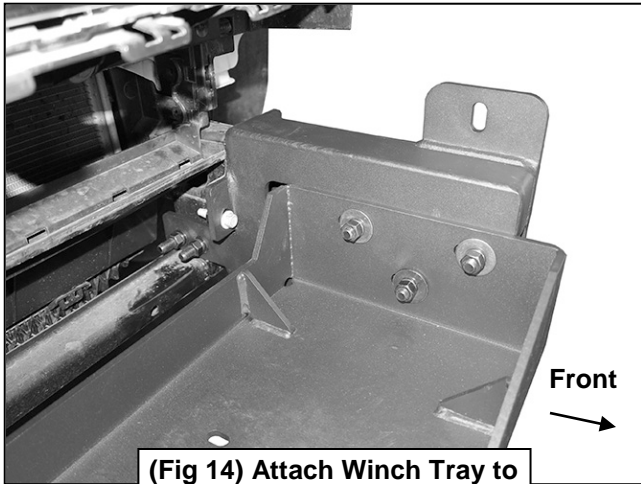

(Fig 14) Attach Winch Tray to Frame Brackets (optional)

- (2) 8mm x 25mm Hex Bolts
- (4) 8mm Flat Washers
- (2) 8mm Lock Washers
- (2) 8mm Hex Nuts

- (2) 8mm x 16mm Hex Bolts
- (2) 8mm Lock Washers
- (2) 8mm Flat Washers

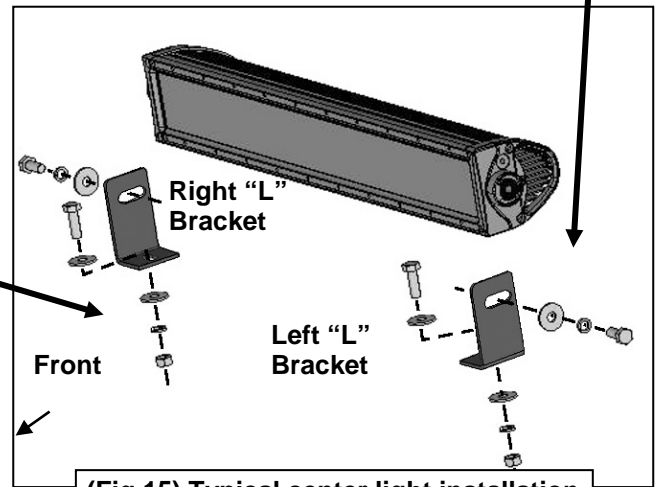

(Fig 15) Typical center light installation

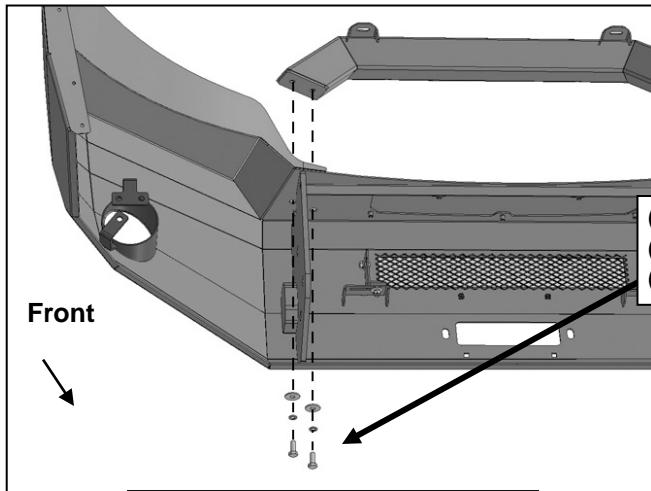

(Fig 16) Attach Bull Nose hoop to top of Bumper (optional)

- (2) 10mm x 25mm Hex Bolts
- (2) 10mm Lock Washers
- (2) 10mm Flat Washers

- (3) 12mm x 40mm Hex Bolts
- (6) 12mm x 37mm Large Flat Washers
- (3) 12mm Lock Washers

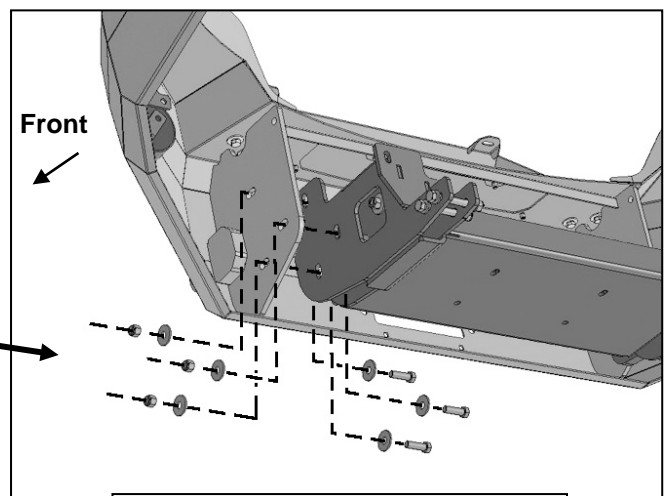

(Fig 17) Attach Bumper assembly to outside of Frame Brackets

WARNING! Do not crawl under bumper unless the bumper is properly supported on blocks or stands or the bumper may fall.

**ELEVATION BULL NOSE FRONT BUMPER
2015-17 CHEVY COLORADO**

Driver/Left Side Installation Pictured

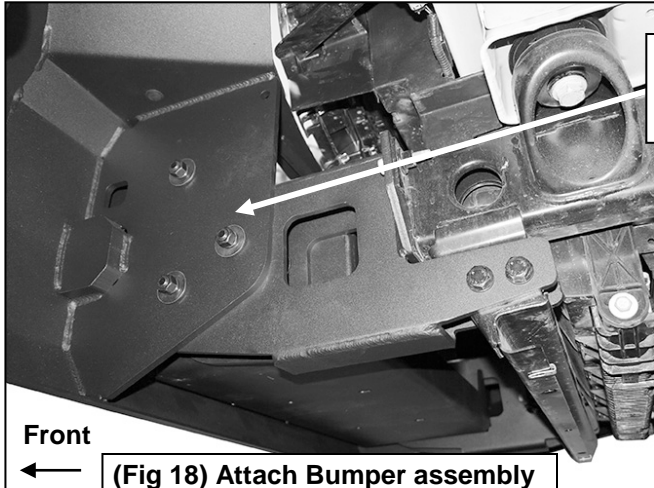

- (3) 12mm x 40mm Hex Bolts
- (6) 12mm x 37mm Large Flat Washers
- (3) 12mm Lock Washers

Front

(Fig 18) Attach Bumper assembly to outside of Frame Brackets

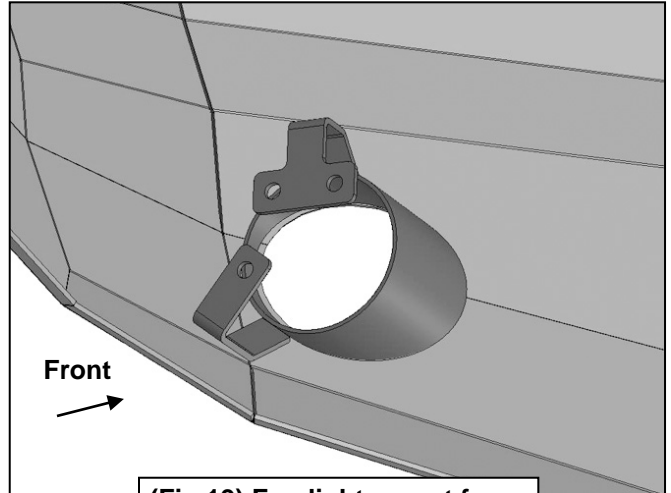

Front

(Fig 19) Fog light mount for factory fog light (if equipped)



(Fig 20) Push pins on fog light into mounting tabs (if equipped)

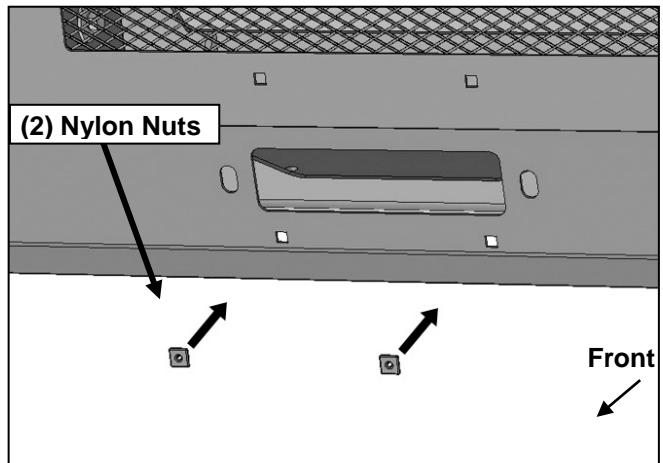

(2) Nylon Nuts

Front

(Fig 21) Attach License Plate Bracket to Bumper



Complete Installation (accessories pictured available separately)