

# **INSTALLATION INSTRUCTIONS**

**ELEVATION FRONT BUMPER  
2018 FORD F150**

**ELEVATION FRONT BUMPER  
2018 FORD F150**

**PARTS LIST:**

1	Elevation Front Bumper Assembly	28	12mm x 37mm x 3mm Flat Washers
1	Driver/Left Frame Mounting Bracket	4	12mm Lock Washers
1	Passenger/Right Frame Mounting Bracket	12	12-1.75mm Nylon Lock Nuts
1	Driver/Left Frame Support Bracket	4	8-1.25mm x 20mm Hex Bolts
1	Passenger/Right Frame Support Bracket	6	8mm x 24mm x 2mm Flat Washers
4	Bracket Spacer Plates	2	8mm x 16mm x 1.6mm Flat Washers
1	Driver/Left Fog Light Upper U-Bracket	4	8mm Nylon Lock Nuts
1	Passenger/Right Fog Light Upper U-Bracket	3	6mm x 25mm Button Head Bolts
2	Lower U-Brackets (Fog Lights)	4	6mm x 16mm Hex Bolts
1	Adapter Cruise Control (ACC) Bracket	7	6mm x 18mm x 1.6mm Flat Washers
1	ACC Plastic Cover	7	6mm Lock Washers
2	Plastic Plugs for license plate mount	3	6mm Hex Nuts
2	12mm Double Nut Plates	1	Allen Wrench S=4
2	12-1.75mm x 170mm Hex Bolts	1	Allen Wrench S=2.5
14	12-1.75mm x 45mm Hex Bolts		

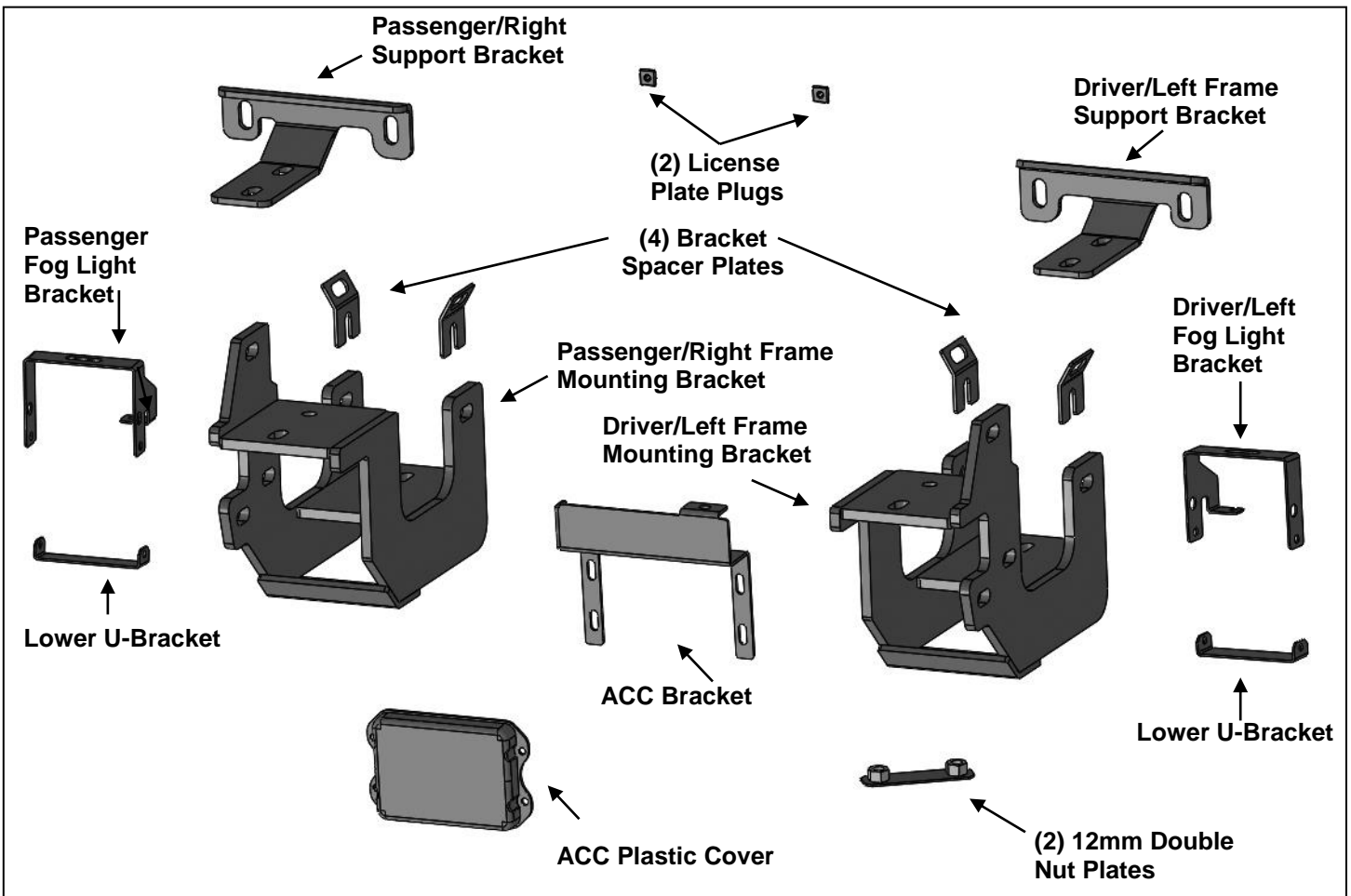

**PROCEDURE:**

REMOVE CONTENTS FROM BOX. VERIFY ALL PARTS ARE PRESENT. READ INSTRUCTIONS CAREFULLY BEFORE STARTING INSTALLATION. BUMPER IS HEAVY, ASSISTANCE IS HIGHLY RECOMMENDED TO AVOID POSSIBLE INJURY OR DAMAGE TO THE VEHICLE.

## ELEVATION FRONT BUMPER 2018 FORD F150

1. Remove the license plate and bracket. On models equipped with factory fog lights, unplug wiring harness leading to Bumper. Unplug adaptive cruise control (ACC), if equipped. Release the wiring harness from the clips attached to the back of the bumper. Move wiring harnesses away from bumper.
2. Next, remove both plastic bumper pad assembly, **(Figure 1)**. Pad is held in place with metal clips. Gently pry the corners of the bumper pad and pull the pad straight out to remove bumper pad.
3. Place blocks or jack stands under the front bumper to support it during mounting bolt removal.  
**WARNING!** Assistance is required to hold the bumper in place during bolt removal to prevent the bumper from falling. Once the bumper has been safely supported, remove the large hex nut from the back of each bumper bracket, **(Figure 2)**. Next, from the front of the bumper, remove the (2) factory hex nuts attaching the bumper to each bumper bracket, **(Figure 3)**. Carefully slide the bumper off over the tow hooks.
4. Remove the driver/left side tow hook and plastic cover, (if equipped), from the bottom of the frame, **(Figure 4)**. Repeat to remove the passenger side tow hook, if equipped.
5. Next, select the driver/left side Frame Mounting Bracket. Slide the Bracket over the end of the frame. Insert (1) 12mm x 175mm Long Hex Bolt with (1) 12mm Flat Washer through the outside of the mounting tab on the Frame Bracket, through the frame and the inside tab on Bracket. Secure with (1) 12mm Flat Washer and (1) 12mm Nylon Lock Nut. Insert (1) Spacer Plate down between each mounting tab and the side of the frame, **(Figures 5—7)**. Do not fully tighten hardware.
6. Insert (1) 12mm Double Nut Plate into the open end of the frame. Attach the Frame Bracket to the bottom of the frame and the Double Nut Plate with (2) 12mm x 45mm Hex Bolts, (2) 12mm Lock Washers and (2) 12mm Flat Washers, **(Figures 5—7)**. **NOTE:** On models with tow hooks, reuse the factory nut plate to attach the Frame Bracket to the bottom of the frame. Leave hardware loose.
7. Select the driver/left side Frame Support Bracket, **(Figure 8)**. Reuse the factory flange nuts to attach the Support Bracket to the factory double bolt plate on the front of the frame, **(Figure 8)**.
8. On models without tow hooks, attach the Support Bracket directly to the top of the Frame Bracket with (2) 12mm x 45mm Hex Bolts, (4) 12mm Flat Washers and (2) 12mm Nylon Lock Nuts, **(Figure 9)**. On models with tow hooks, attach the tow hook to the inside of the frame and repeat step to attach the tow hook to the frame bracket and the Support Bracket, **(Figure 10)**. **IMPORTANT:** On models with tow hooks AND an adaptive cruise control, ONLY the passenger side tow hook may be reinstalled. Refer to **Step 12**. Do not tighten hardware at this time.
9. Repeat **Steps 5—8** to install the passenger/right side Frame Bracket assembly.
10. If equipped with factory fog lights, remove the complete light assemblies from the back of the bumper, **(Figure 11)**. Remove the adaptive cruise control, if equipped.
11. **Models with factory fog lights:**
  - a. Use a flat blade screwdriver to carefully pop out the tabs on the side of the fog light bracket attaching the light to the bracket, **(Figure 11)**. Pop the light out of the plastic bracket housing.
  - b. Remove the adjustment screw and spring from the light assembly.
  - c. Select the driver top U Bracket, **(Figure 12)**. Attach the Bracket to the slot in the light opening with (1) 8mm x 20mm Hex Bolt, (2) 8mm Flat Washers and (1) 8mm Nylon Lock Nut, **(Figure 12)**.
  - d. Carefully spread the sides of the Bracket enough to slide the OE plastic fog light between and into the Bracket, **(Figure 13)**. Attach (1) Lower U Bracket to the Upper Bracket with (2) 6mm x 16mm Hex Bolts, (2) 6mm Lock Washers and (2) 6mm Flat Washers, **(Figure 14)**.
  - e. Insert the factory spring between the tab on the Bracket and the light. Insert the screw through the tab, spring and into the fog light, **(Figures 14 & 15)**.
  - f. Repeat to install the passenger/right fog light.
12. Determine if vehicle is equipped with an adaptive cruise control, (ACC). Install the ACC assembly onto Bumper before mounting Bumper to end of frame. **Vehicles without ACC**, continue to **Step 13**.  
**Vehicles with ACC:**
  - a. Insert (3) 6mm x 25mm Button Head Bolts through the (3) holes on the ACC Plastic Cover, the ACC Bracket and out through the adaptive cruise control. Secure with (3) 6mm Flat Washers, (3) 6mm Lock Washers and (3) 6mm Hex Nuts, **(Figures 16 & 17)**.
  - b. Attach the ACC Bracket assembly to the mounting tabs on the back of the bumper with (2) 8mm x 20mm Hex Bolts, (2) 8mm x 24mm Flat Washers (**top**), (2) 8mm x 16mm Flat Washers (**bottom**) and (2) 8mm Nylon Lock Nuts, **(Figure 18)**.

**ELEVATION FRONT BUMPER  
2018 FORD F150**

13. On models with grille mounted factory camera, remove the center screen, **(Figure 19)**.
14. With assistance, position the Bumper Assembly onto the outsides of the Frame Brackets. Temporarily support the weight of the Bumper. **WARNING:** To avoid possible injury or damage to the vehicle, do not proceed until the bumper is fully and safely supported.
15. Attach the Bumper to the Brackets with the included (6) 12mm x 45mm Hex Bolts, (12) 12mm Flat Washers and (6) 12mm Nylon Lock Nuts, **(Figures 20 & 21)**. Snug but do not tighten hardware.
16. Level and adjust the bumper and fully tighten all hardware. **NOTE:** If additional in-out adjustment is required, loosen Frame Bracket Hardware, slide the Bracket in or out as necessary and fully tighten all hardware.
17. Reattach the wiring harness. Adjust lights as necessary and tighten all fog light bracket hardware.
18. Use the included (2) push-in plastic nuts to attach the front license plate, (if required), to the (2) holes in the front bumper, **(Figure 22)**.
19. Do periodic inspections to the installation to make sure that all hardware is secure and tight.

**To protect your investment**, wax this product after installing. Regular waxing is recommended to add a protective layer over the finish. Do not use any type of polish or wax that may contain abrasives that could damage the finish. Mild soap may be used to clean the Front Bumper assembly.



**(Fig 1) Remove plastic bumper pad from bumper (Driver/left side Pictured)**



**(Fig 2) Remove factory hex nut (arrow) from back of bumper bracket (Driver side pictured)**

**WARNING!** Do not remove bumper bolts unless the bumper is properly supported on blocks or stands or the bumper may fall.

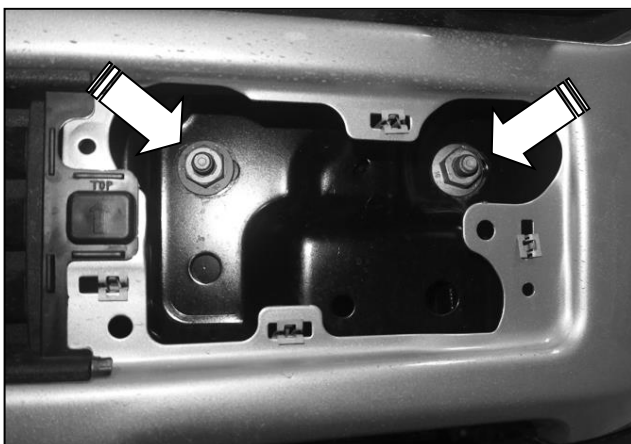

**(Fig 3) Remove (2) factory hex nuts from each side**

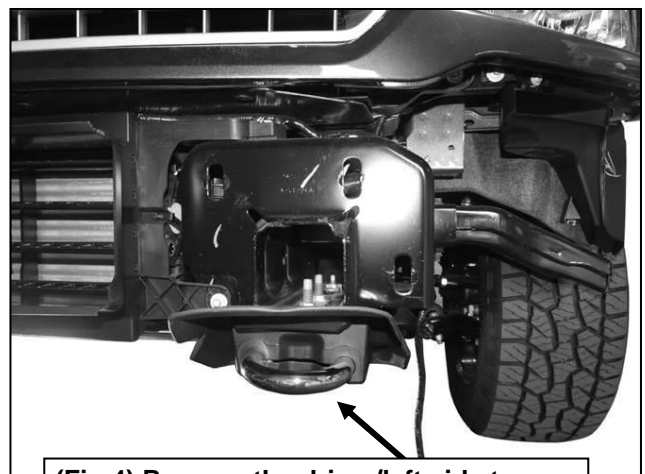

**(Fig 4) Remove the driver/left side tow hook and plastic cover, (if equipped)**

Driver/left Side Installation Pictured

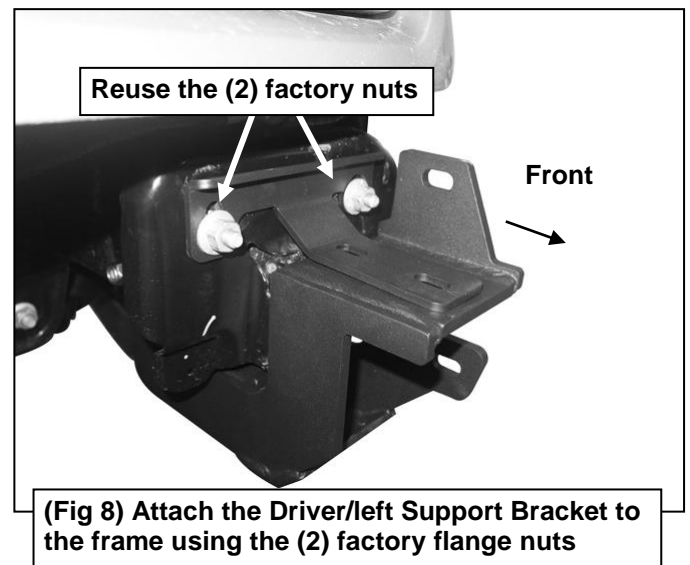
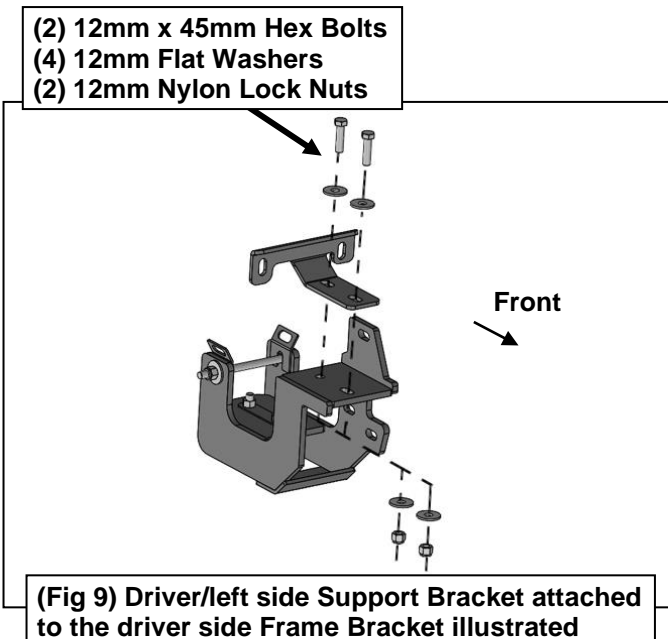
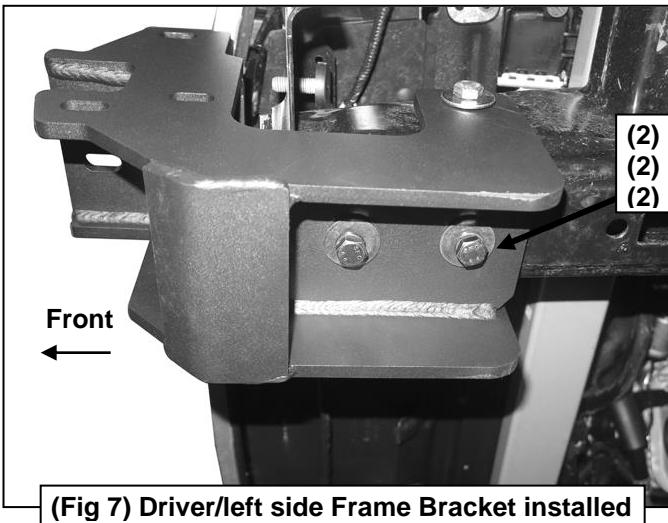
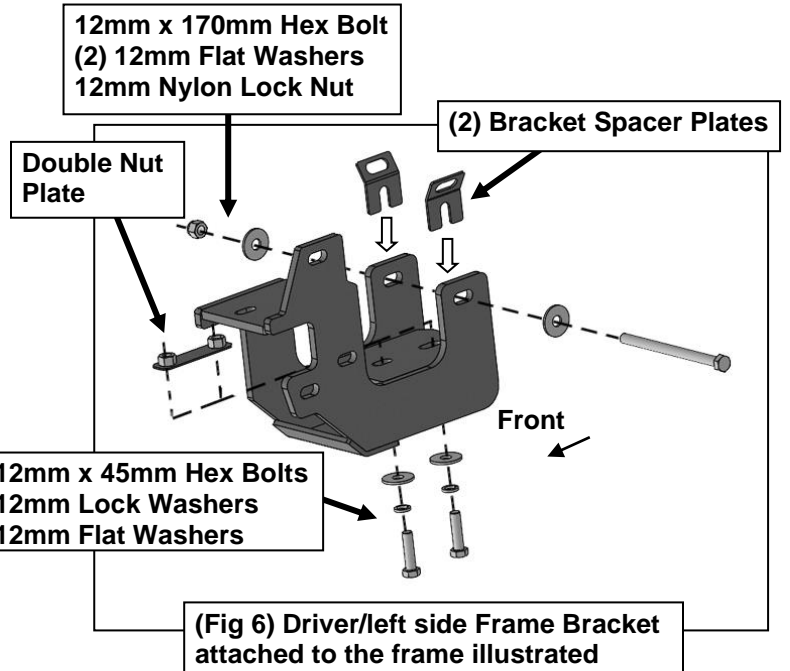
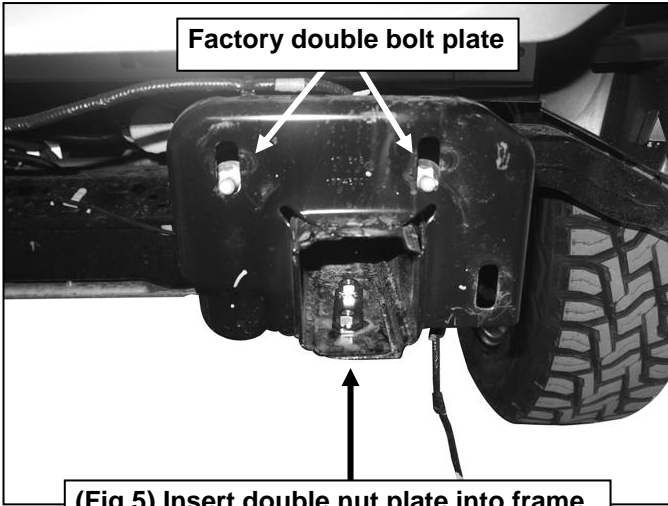

Driver/left Side Installation Pictured

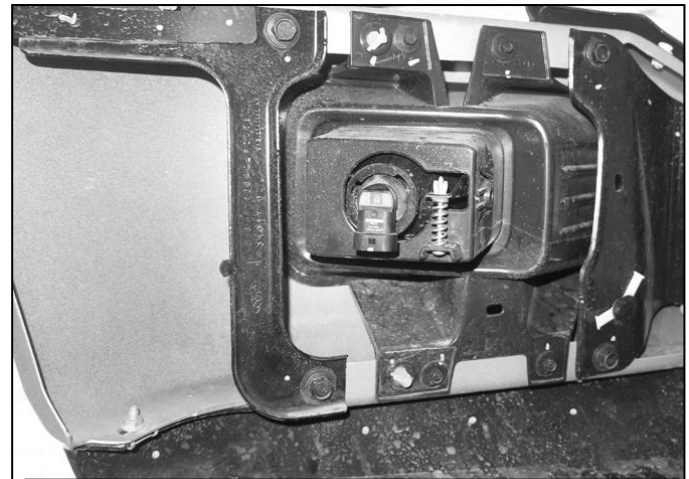
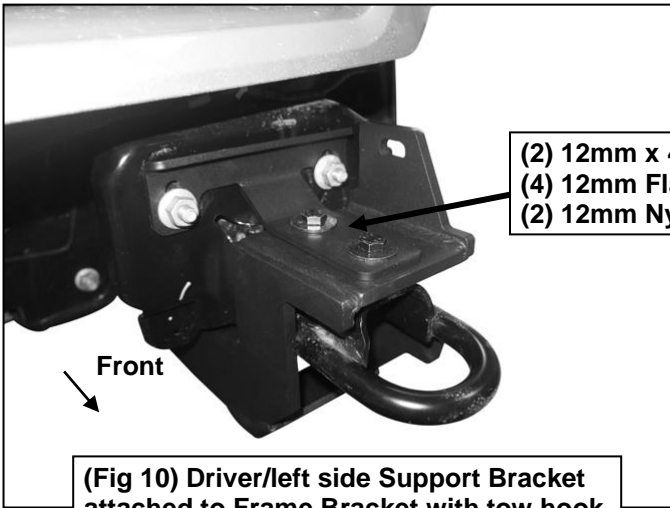

(Fig 11) Remove fog light assembly from bumper

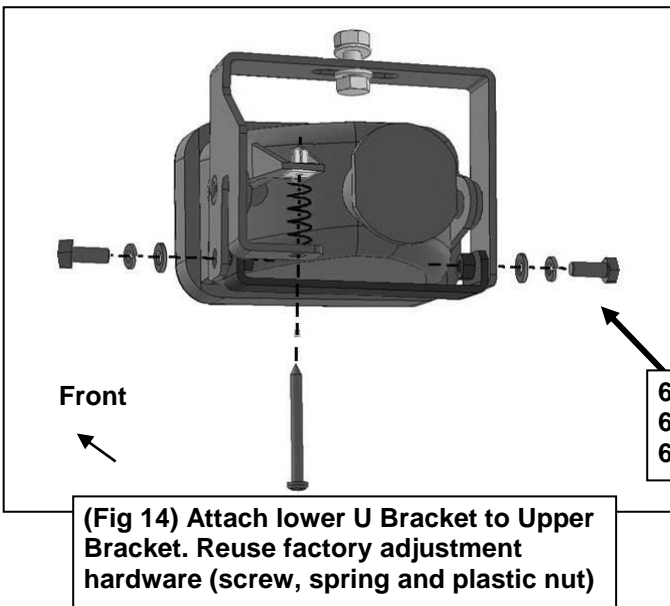
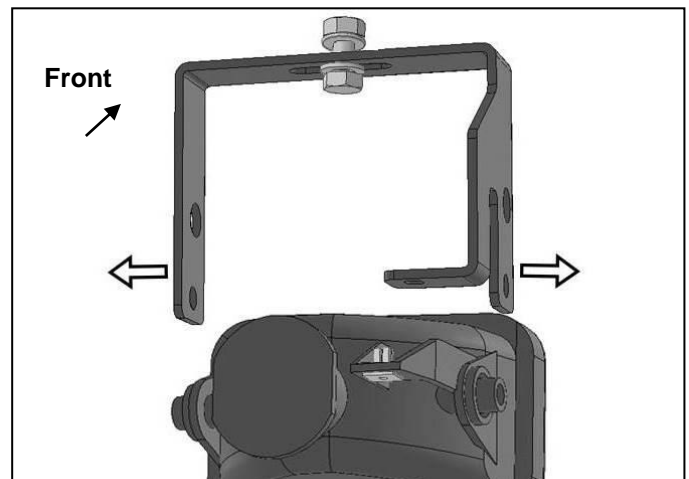
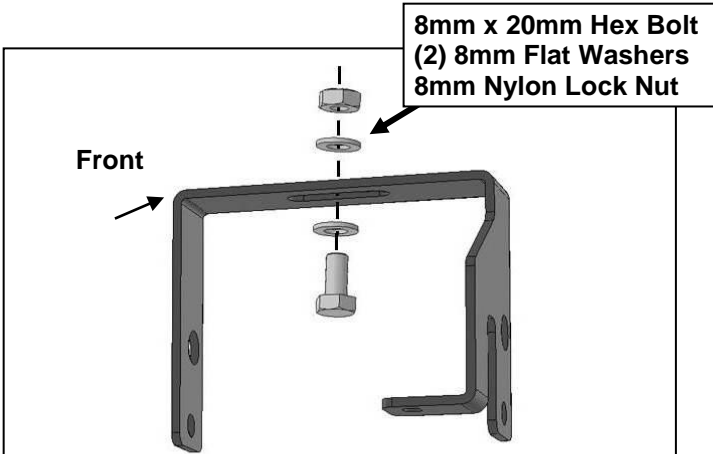

Driver/left Side Installation Pictured

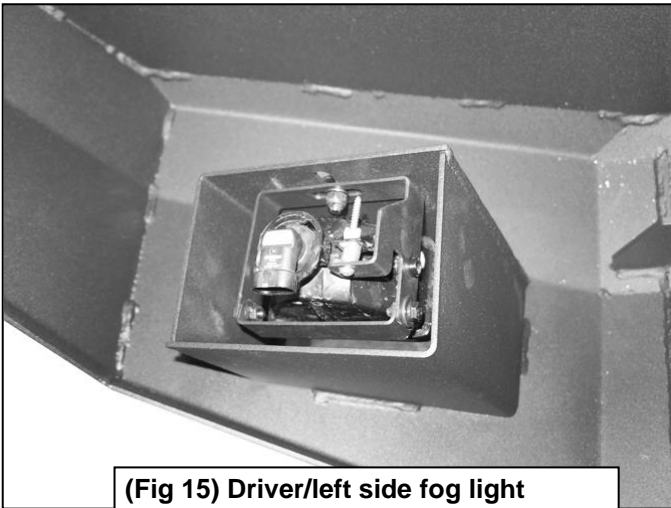

(Fig 15) Driver/left side fog light assembly attached to back of Bumper

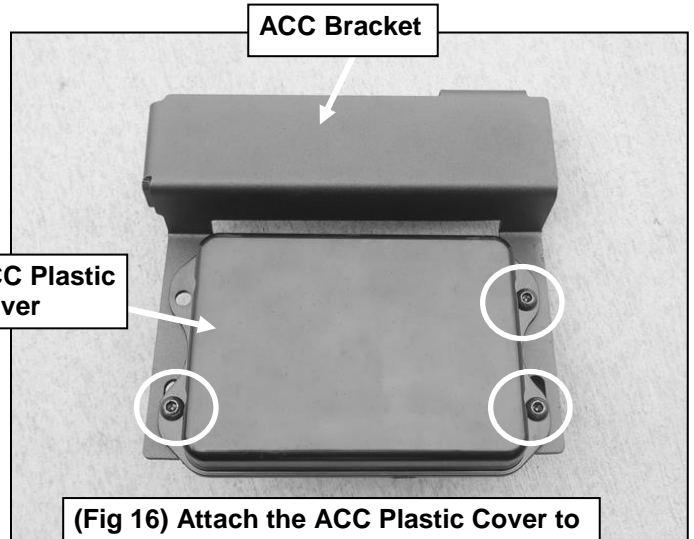

(Fig 16) Attach the ACC Plastic Cover to the front of the ACC Bracket

- (3) 6mm x 25mm Button Head Bolts
- (3) 6mm x 18mm Flat Washers
- (3) 6mm Lock Washers
- (3) 6mm Hex Nuts

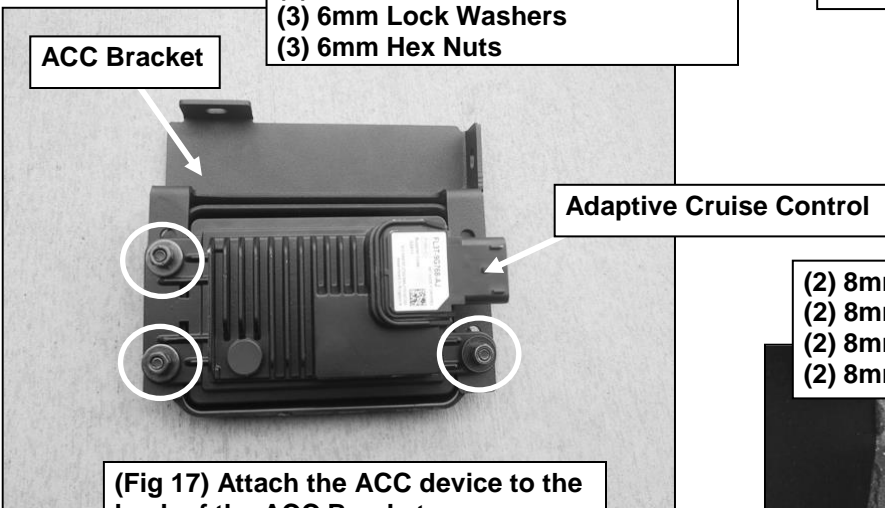

(Fig 17) Attach the ACC device to the back of the ACC Bracket

- (2) 8mm x 20mm Hex Bolts
- (2) 8mm x 24mm Flat Washers (Top)
- (2) 8mm x 16mm Flat Washers (Bottom)
- (2) 8mm Nylon Lock Nuts

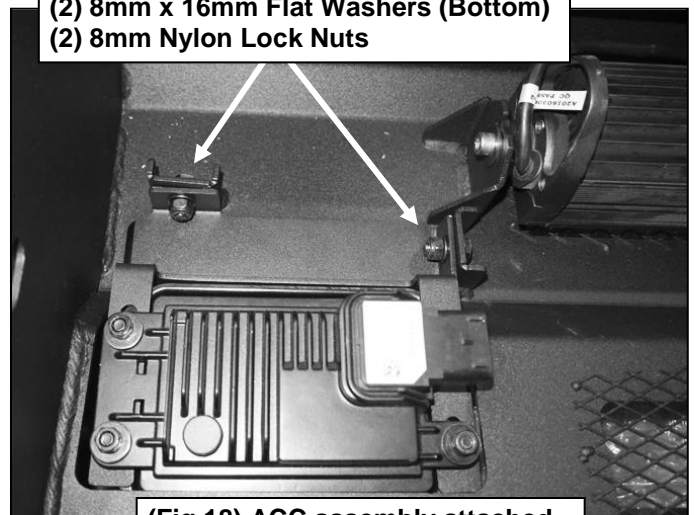

(Fig 18) ACC assembly attached to the back of the Bumper

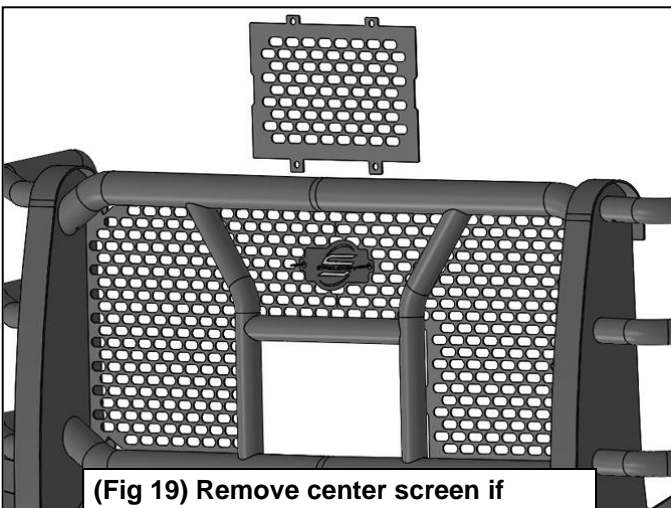

(Fig 19) Remove center screen if equipped with grille mounted camera

Driver/left Side Installation Pictured

**WARNING!** Do not crawl under bumper unless the bumper is properly supported on blocks or stands or the bumper may fall.

- (3) 12mm x 45mm Hex Bolts
- (6) 12mm Flat Washers
- (3) 12mm Nylon Lock Nuts

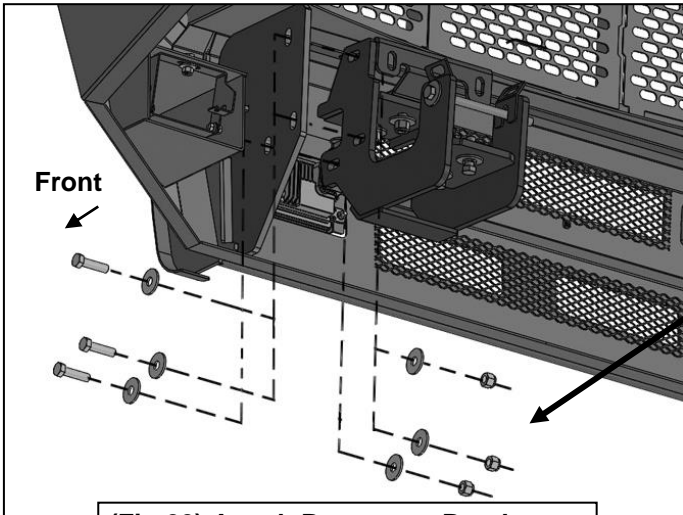

(Fig 20) Attach Bumper to Brackets

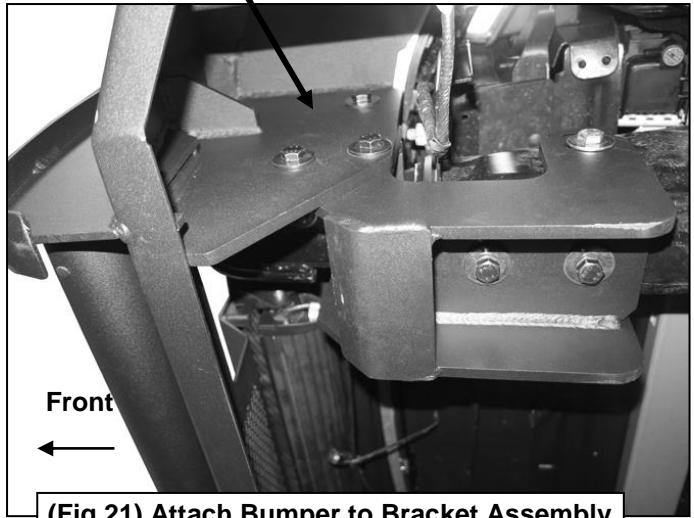

(Fig 21) Attach Bumper to Bracket Assembly

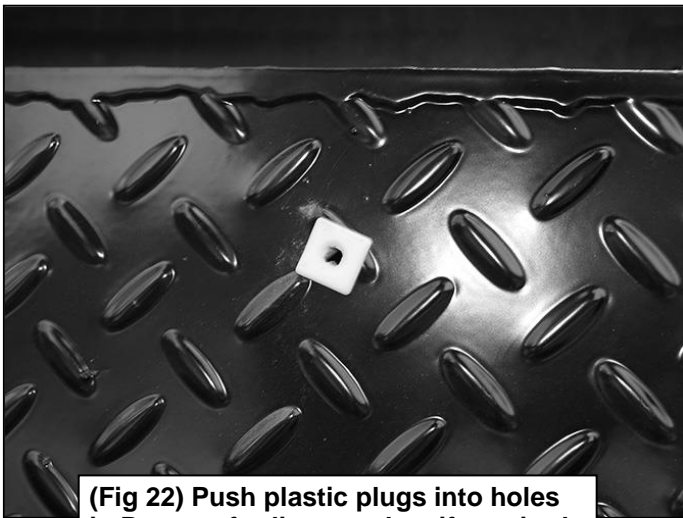

(Fig 22) Push plastic plugs into holes in Bumper for license plate if required

