



INSTALLATION INSTRUCTIONS

SPORTSMAN WINCH MOUNT GRILLE GUARD /
HDX WINCH MOUNT GRILLE GUARD / MAX WINCH MOUNTING SYSTEM

APPLICATION:

2016 Chevrolet Silverado 1500

PART NUMBER:

40-93875, 45-93870, 57-93870, 57-93875, 46-23875

AUTOMOTIVE PRODUCTS,

ITEM	QUANTITY	DESCRIPTION	TOOLS NEEDED
1	1	WINCH TRAY	15MM SOCKET
2,3	2	WINCH TRAY MOUNTING BRACKETS, (2) DRIVER AND (3) PASSENGER	18MM SOCKET
4	2	SPACER BRACKET (ONLY USED WITH WINCH TRAY GRILLE GUARD KITS)	15MM WRENCH
5	4	SHORT M12 HEX HEAD CAP SCREW (BLACK ZINC)	18MM WRENCH
6	6	SMALL M12 FLAT WASHER (BLACK ZINC)	SCREW DRIVER
7	6	M12 SPLIT LOCK WASHER (BLACK ZINC)	UTILITY KNIFE
8	2	M12 HEX NUT (BLACK ZINC)	RATCHET
9	2	LONG M12 HEX HEAD CAP SCREW (BLACK ZINC)	TORQUE WRENCH
10	2	M10 HEX HEAD FLANGE BOLT (BLACK ZINC)	
11	2	M10 HEX HEAD SERRATED FLANGE NUT (BLACK ZINC)	
12	2	LARGE M12 FLAT WASHER (BLACK ZINC)	
13	4	M12 HEX FLANGE BOLT (BLACK ZINC)	
14	4	M12 HEX HEAD SERRATED FLANGE NUT (BLACK ZINC)	
15	1	GRILLE GUARD ASSEMBLY	PARTS COME WITH WINCH MOUNT GRILLE GUARD KITS ONLY (ITEMS 15 - 25)
16, 17	2	TOP SUPPORT STRAP, (16) DRIVER AND (17) PASSENGER	
18	4	M12 HEX HEAD FLANGE BOLT (BLACK ZINC)	
19	8	M12 HEX HEAD SERRATED FLANGE NUT (BLACK ZINC)	
20	2	M10 HEX SOCKET BUTTON HEAD SCREW (RAW OR BLACK ZINC)	ITEMS 20 - 25 ARE STAINLESS STEEL
21	4	M10 FLAT WASHER (RAW OR BLACK ZINC)	
22	2	M10 SPLIT LOCK WASHER (RAW OR BLACK ZINC)	
23	2	M10 HEX NUT (RAW OR BLACK ZINC)	
24	4	M12 FLAT WASHER (RAW OR BLACK ZINC)	
25	4	M12 HEX SOCKET BUTTON HEAD SCREW (RAW OR BLACK ZINC)	

ANTI-SEIZE LUBRICANT MUST BE USED ON ALL STAINLESS STEEL FASTENERS TO PREVENT THREAD DAMAGE AND GALLING

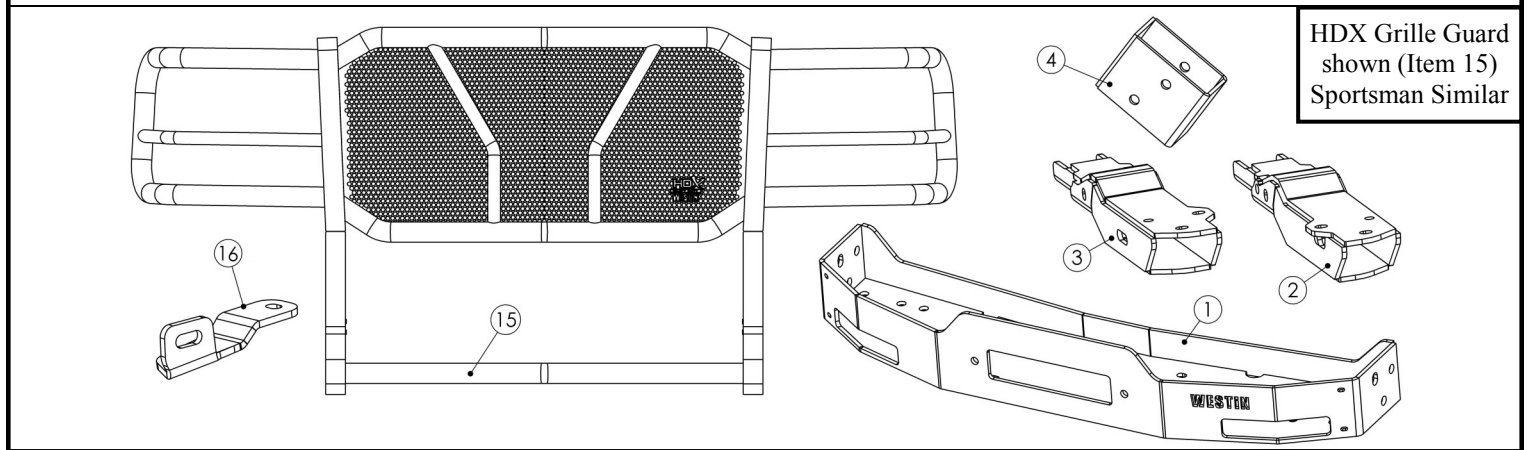

Westin Automotive Products, Inc.
320 W. Covina Blvd
San Dimas, Ca. 91773

Thank you for choosing Westin products
for additional installation assistance please call
Customer Service (800) 793-7846

PROCEDURE

1. Remove contents from box, verify if all parts listed are present and free from damage.

Carefully read and understand all instructions before attempting installation.

Failure to identify damage before installation could lead to a rejection of any claim.

2. Remove the radiator cover to reveal screws that attach the grille to the front of vehicle. See **Figure 1**.
3. Remove the screws that attach the grille to the front of vehicle. Carefully pull the grille off the vehicle. See **Figure 2**.

Pull up all fasteners and remove plastic radiator cover.

Figure 1



Remove screws that attach the grille to the vehicle.

Figure 2

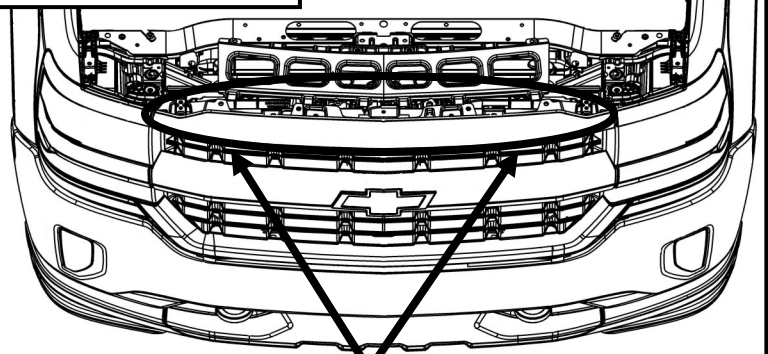

Screws are found around this area.

4. Remove the front bumper assembly. (This is only necessary on vehicles with factory tow hooks.) See **Figures 3 and 4**.

Figure 3

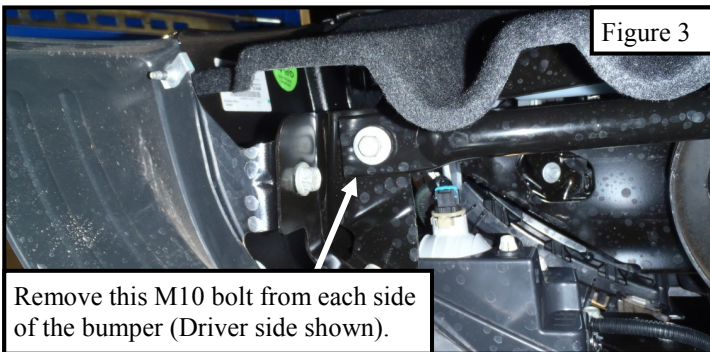

Remove this M10 bolt from each side of the bumper (Driver side shown).

Figure 4

Remove these M12 bolts from each side of the bumper (Driver side shown).

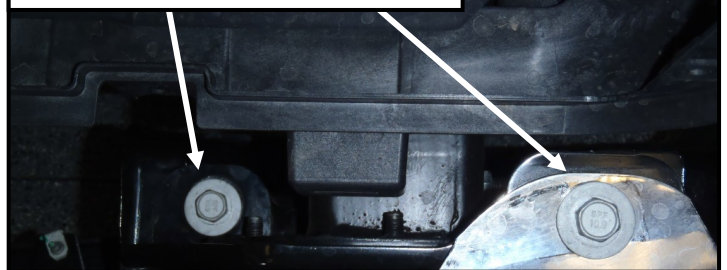

5. **For models with factory tow hooks:** Remove the tow hooks and the foam tow hook covers. Minor trimming is required on the tow hook covers. Tow hooks cannot be reinstalled. See **Figures 5 and 6**.

6. **For models without factory tow hooks:** Cut-out the tow hook pockets in the front valance.

Figure 5

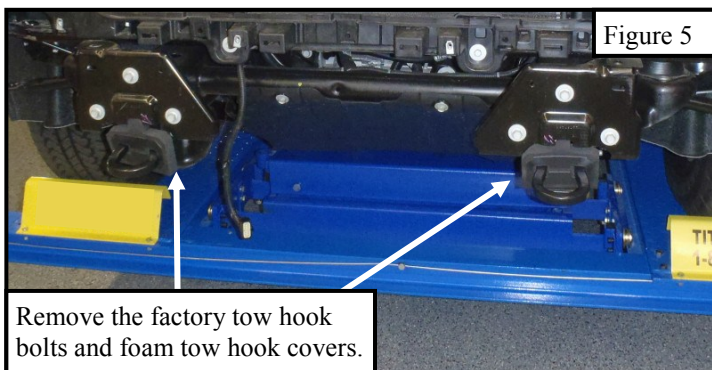

Remove the factory tow hook bolts and foam tow hook covers.

Figure 6

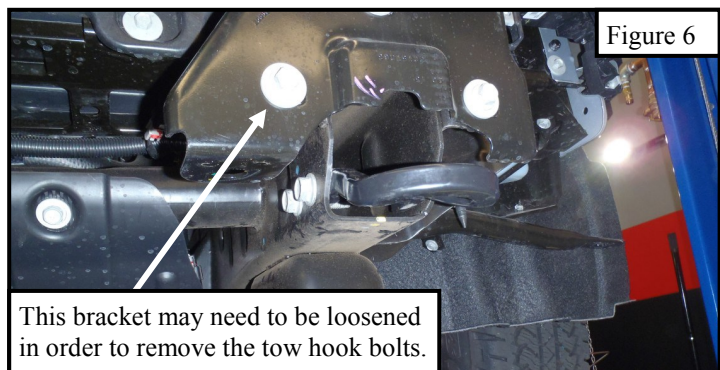

This bracket may need to be loosened in order to remove the tow hook bolts.

Westin
SIGNATURE OF QUALITY

Westin Automotive Products, Inc.
320 W. Covina Blvd
San Dimas, Ca. 91773

Thank you for choosing Westin products
for additional installation assistance please call
Customer Service (800) 793-7846

www.westinautomotive.com

7. Locate (1) Winch Tray Mounting Bracket (Item 2/3) . Loosely attach the Winch Tray Mounting Bracket to frame rail using the provided hardware: (1) long M12 hex head cap screw, (2) short M12 hex head cap screw, (3) small M12 flat washers, (3) M12 lock washers, (1) large M12 flat washer, and (1) M12 hex nut. Repeat for other side. **See Figure 7.**
8. Loosely install the Winch Tray to the mounting brackets using the supplied M10 hardware (Items 10 and 11) and the supplied M12 hardware (Items 13 and 14). **See Figure 8.**

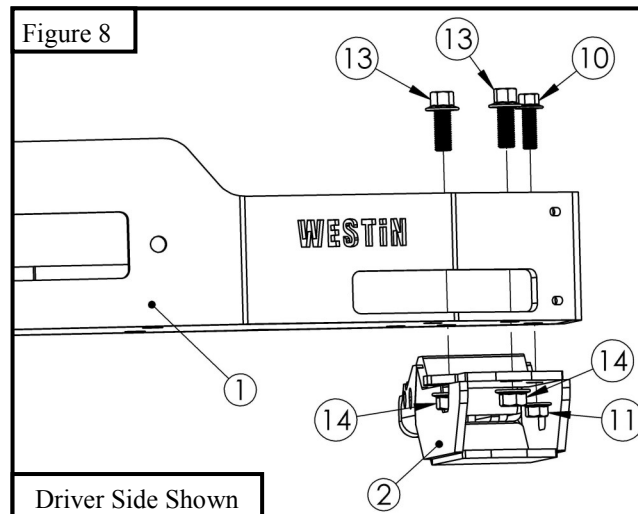
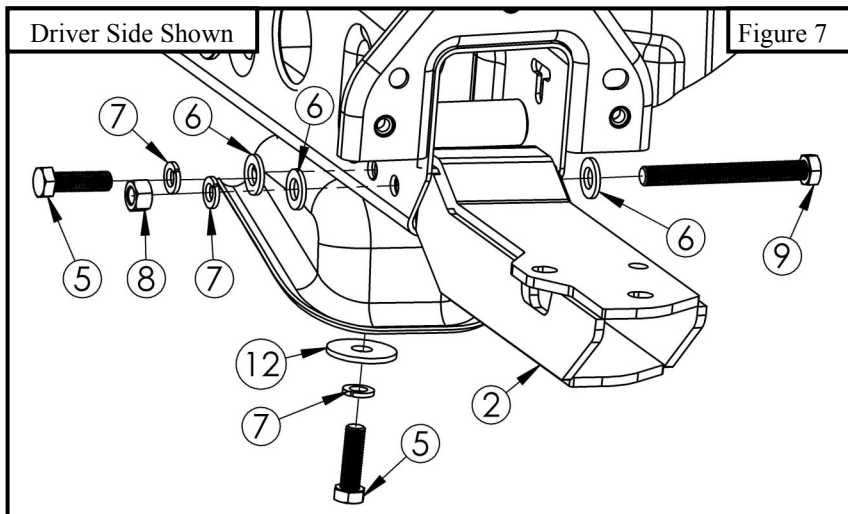

9. Tighten and torque M10 hardware to 30-35 ft-lb and M12 to 50-55 ft-lb.
10. Locate (1) Top Support Strap (Item 16/17). Remove factory hardware at mounting location. Loosely install Top Support Strap with the factory hardware located at the mounting location. Adjust them so that they are approximately 20-5/8" from the center of the bumper then torque the factory hardware to 50-55 ft-lb. Repeat for other side. **See Figures 9, 10 and 11.**
11. Re-install the bumper and grille guard in the reverse order that it was removed. Note: Tow hook pocket trimming will be required to accomplish this step.

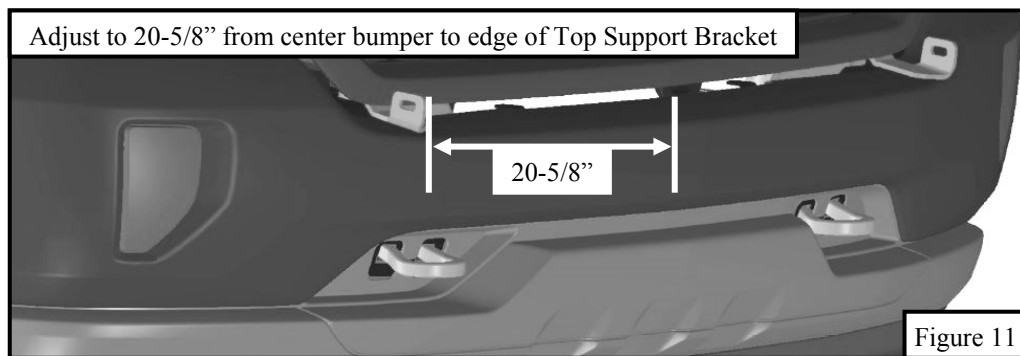
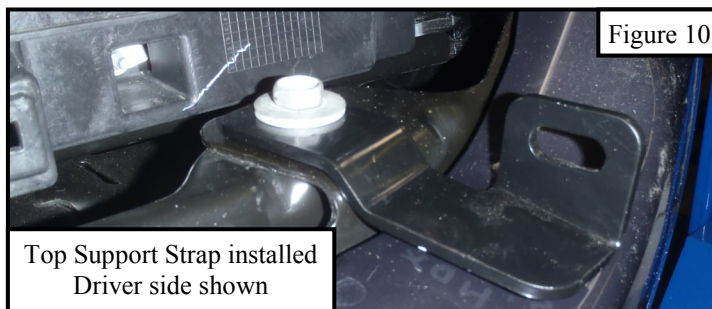
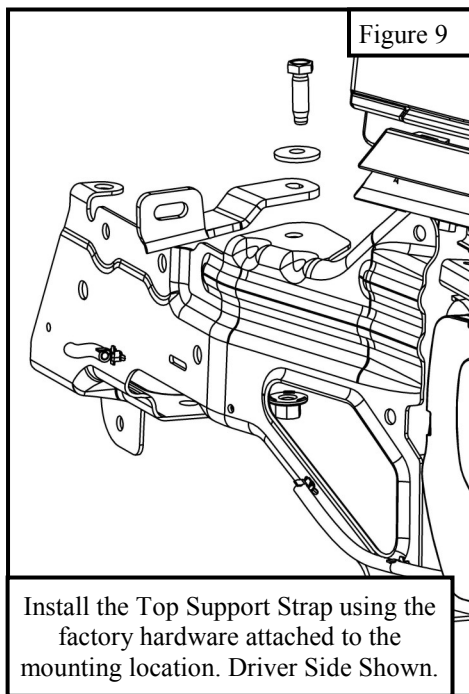

Westin Automotive Products, Inc.
320 W. Covina Blvd
San Dimas, Ca. 91773

12. Locate and attach both Spacer Brackets (Item 4) to the Winch Tray using (4) M12 hex head flange bolt and (4) M12 hex head serrated flange nut. **See Figure 12.**
13. Install Winch per Winch Manufacturer's Instructions. **Note:** It may be very difficult to install the winch after the Grille Guard has been installed.
14. With assistance loosely install the Grille Guard Assembly (Item 15) onto the previously installed spacer brackets. Loosely bolt the Grille Guard to the Top Support Straps (Items 16 & 17) using the supplied M12 hardware (Items 20-23). **See Figure 13.**
15. Align and adjust the Grille Guard Assembly as necessary. Tighten all remaining hardware: M10 to 30-35 ft-lbs and M12 to 50-55 ft-lbs.

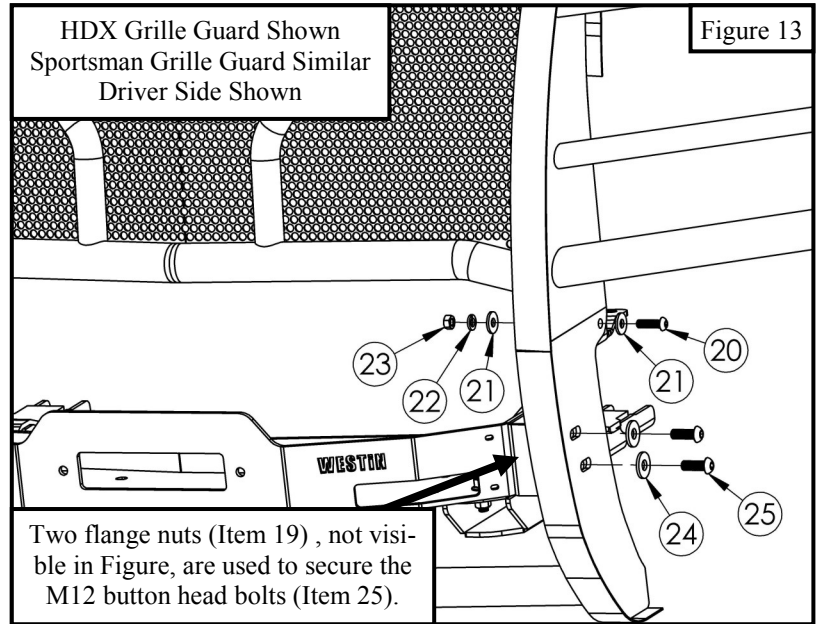
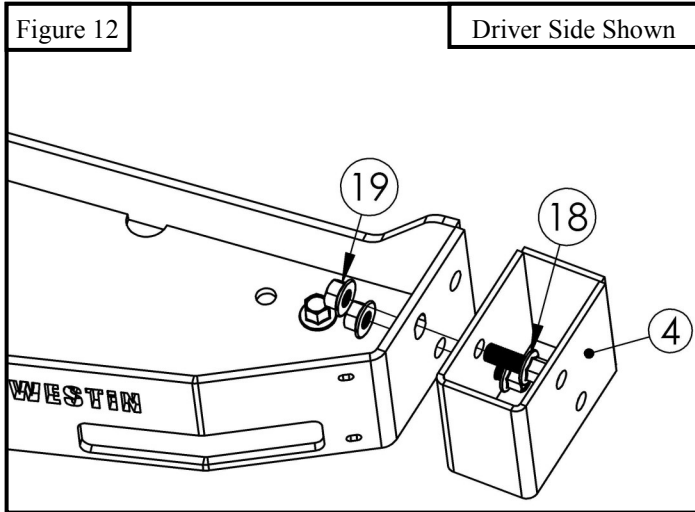

CARE INSTRUCTIONS

- REGULAR WAXING IS RECOMMENDED. DO NOT USE ANY TYPE OF POLISH OR WAX THAT MAY CONTAIN ABRASIVES.
- STAINLESS STEEL PRODUCTS CAN BE CLEANED WITH MILD SOAP AND WATER. STAINLESS STEEL POLISH SHOULD BE USED TO POLISH SMALL SCRATCHES.
- GLOSS BLACK FINISHES SHOULD BE CLEANED WITH MILD SOAP AND WATER.



Westin Automotive Products, Inc.
320 W. Covina Blvd
San Dimas, Ca. 91773

Thank you for choosing Westin products
for additional installation assistance please call
Customer Service (800) 793-7846

Westin

SIGNATURE OF QUALITY

AUTOMOTIVE PRODUCTS, INC.



WARNING



Failure to follow these instructions could lead to death, personal injury, and / or property damage.

FASTENERS:

All Westin supplied fasteners must be utilized and installed in accordance with the installation instructions and apply torque to the specifications as defined. **DOUBLE CHECK ALL FASTENERS BEFORE INITIAL USE, AND PERIODICALLY IN THE FUTURE TO ENSURE PROPER FUNCTION AND SAFETY.**

DRILLING:

Most Westin products do not require drilling for installation. If drilling is defined as required, use caution when drilling a vehicle. **FAILURE TO REVIEW AN AREA TO BE DRILLED MAY RESULT IN PERSONAL INJURY AND/OR INJURY TO OTHERS AS WELL AS VEHICLE DAMAGE.**

EYE PROTECTION:

ALWAYS WEAR SAFETY GLASSES OR GOGGLES DURING THE INSTALLATION PROCESS TO AVOID PERSONAL INJURY.

MAXIMUM TOWING/CARRYING CAPACITY:

The Westin Receiver Hitches will have a visible tow rating label affixed directly on the product. User should never exceed the vehicle manufacturers maximum tow and weight rating regardless of the capacity of the hitch. **FAILURE TO FOLLOW THESE GUIDELINES WILL VOID THE WESTIN WARRANTY AND MAY RESULT IN PERSONAL INJURY AND/OR INJURY TO OTHERS AS WELL AS VEHICLE DAMAGE.**

Westin
SIGNATURE OF QUALITY

Westin Automotive Products, Inc.
320 W. Covina Blvd
San Dimas, Ca. 91773