

INSTALL INSTRUCTIONS

IDENTITY FRONT BUMPER

Product Range : 2152DF & 3152DF

Application : 2015—2018 CHEVY / GMC 2500,3500

(THIS APPLIES TO ALL IDENTITY SERIES FRONT BUMPERS)

I WARNING

Read the instructions completely before beginning installation. Before tightening bolts, drilling or cutting where required, check to make sure there are no obstructions such as brake, fuel or electrical lines which may be damaged. Also keep in mind this is an aftermarket product and MAY require minor shimming and/or trimming, reaming, etc. for proper fit. Road Armor is not responsible for any damages to vehicle.

ⓘ IMPORTANT NOTICE

- Be sure to inspect and test fit your product to ensure proper fitment before having it coated, painted, bed lined, etc.
- Road Armor will not be responsible for the cost of coating your unit if any problems with fit or finish are not noted and addressed beforehand.

SAFETY FIRST!

- FOLLOW ALL INSTRUCTIONS, YOUR SAFETY AND THE SAFETY OF OTHERS IS MOST IMPORTANT.
- WEAR APPROPRIATE EYE PROTECTION AND EXERCISE CAUTION WHEN DRILLING / CUTTING

REQUIRED TOOL

SAE & Metric Sockets and Wrenches Black Spray Paint
 Drill and 1/2 – 9/16 or Step bit Tape Measure
 Allen wrenches

INCLUDED HARDWARE

- 40 #10-24 x 1/2" ASTM F835 Hex Drive Zinc Finish Alloy Steel Button Socket Cap Screw
- 16 #10-24 Zinc Finish Steel with External Tooth Lock washer K-Lock Nut
- 6 1.5" Single Bolt Tab (ZINC)
- 20 1/2" x 1.375" OD Yellow Zinc Finish Steel USS General Purpose Flat Washer
- 20 1/2" Yellow Zinc Finish High Alloy Medium Split Lock Washer
- 14 1/2"-13 Yellow Zinc Finish Grade 8 Finished Hex Nut
- 8 1/2"-13 x 1-1/2" Grade 5 Round Head Zinc Finish Partial Thread Carriage Bolt
- 8 1/2" Bolt 15/16" O.D. Zinc Push nut Bolt Retainer
- 6 1/2"-13 x 1-1/2" Grade 8 Yellow Zinc Finish Hex Cap Screw
- 12 7/16"-14 x 1-1/2" Grade 5 Zinc Finish Hex Cap Screw
- 24 7/16" x 1.250" OD Yellow Zinc Finish Steel USS General Purpose Flat Washer
- 12 7/16"-14 Zinc Finish Grade 5 Finished Hex Nut
- 12 7/16" Yellow Zinc Finish High Alloy Medium Split Lock Washer
- 6 5/16"-18 x 3/4" Zinc Finish Grade 5 Short Square Neck Round Head Carriage Bolt
- 6 5/16"-18 Zinc Finish Grade A Finished Hex Nut
- 6 5/16" x 0.875" OD Low Carbon Zinc Finish Steel USS General Purpose Flat Washer
- 4 1/4" x 0.734" OD Low Carbon Zinc Finish Steel USS General Purpose Flat Washer
- 2 1/4"-20 Zinc Finish Grade A Finished Hex Nut
- 2 1/4"-20 x 1" Grade 5 Zinc Finish Hex Cap Screw

KIT COMPONENT LIST

- 1 Main Center Section
- 1 Driver Pod
- 1 Passenger Pod
- 1 Driver Light Pod
- 1 Passage Light Pod
- 1 Passenger Side Lower Light Bracket
- 1 Driver Side Lower Light Bracket
- 2 Carriage Bolt Plates
- 1 Main Driver Light Bracket
- 1 Main Passenger Light Bracket
- 1 Passenger Frame Bracket
- 1 Driver Frame Bracket
- 1 Logo Back Plate
- 1 Center Main Mesh
- 1 Driver Pod Mesh
- 1 Passenger Pod Mesh

- 1 Remove screws holding inner fender well to bumper
- 2 Remove bumper stiffeners both sides and unplug harness
- 3 Remove tow hooks both sides
- 4 Remove bumper bolts 4 total and pull off bumper
- 5 Remove OEM bumper brackets and paint the raw metal revealed

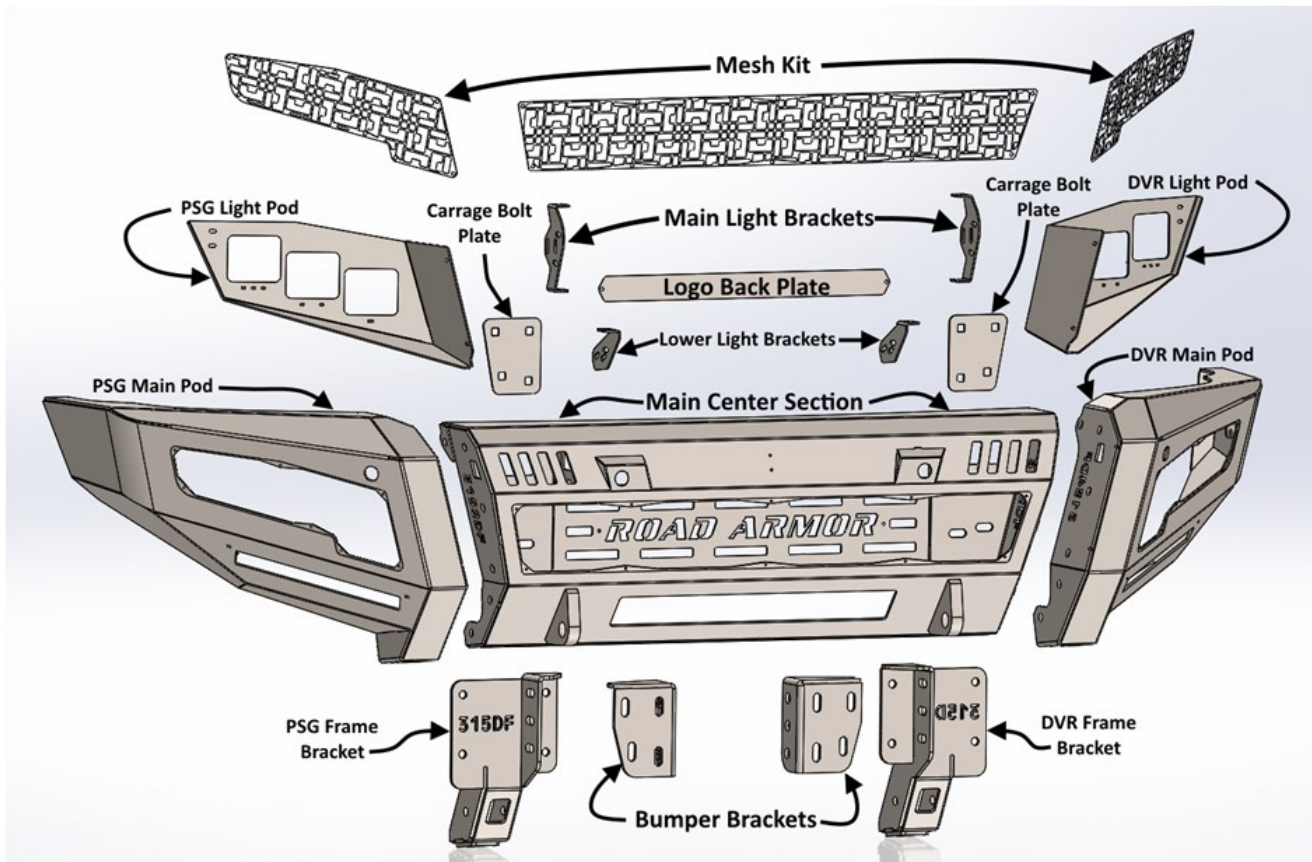
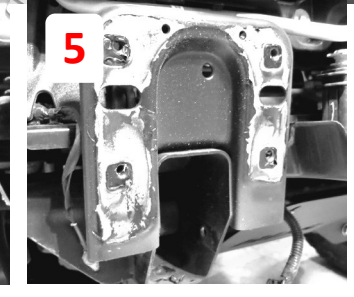
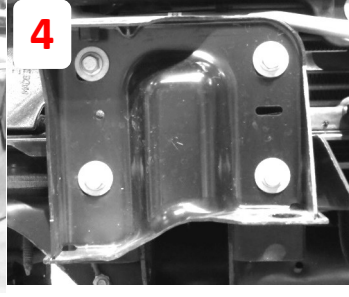
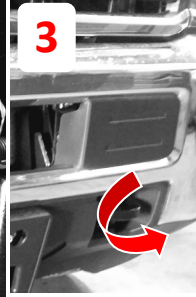
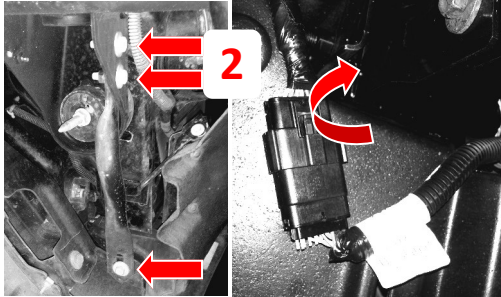
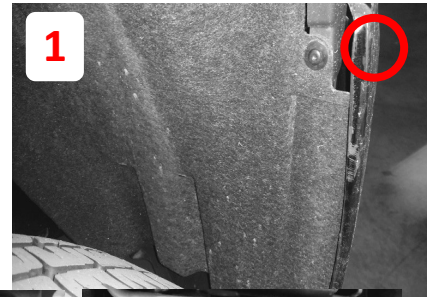

- 6** Assemble light pod into pod end using Qty: 5 - #10-24x1/2" kit bolt and lock nut in each pod.
- 7** Install both kit 12" Accent/DRL lights into pods using Qty: 2 - #10-24x1/2" kit bolt and lock nut in each pod.

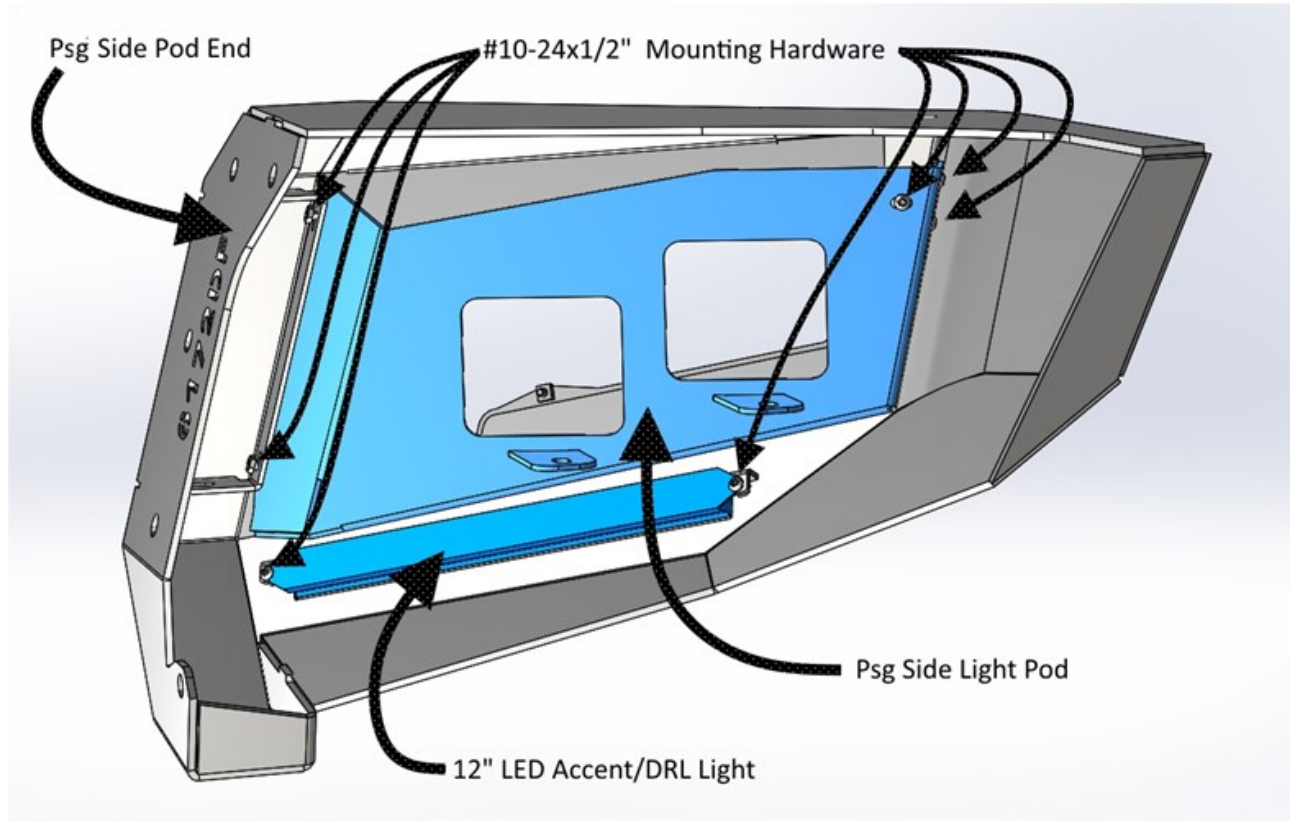

8

***Install the RA Logo Plate Shield Now ***

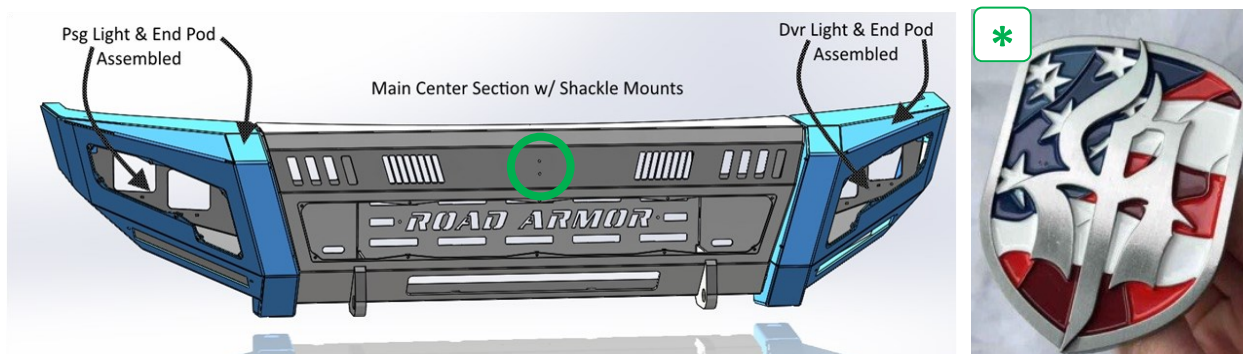

8 Align and install each kit pod end using Qty: 6 – 7/16" x 1 1/2" bolts, nuts, lock washers and washers.

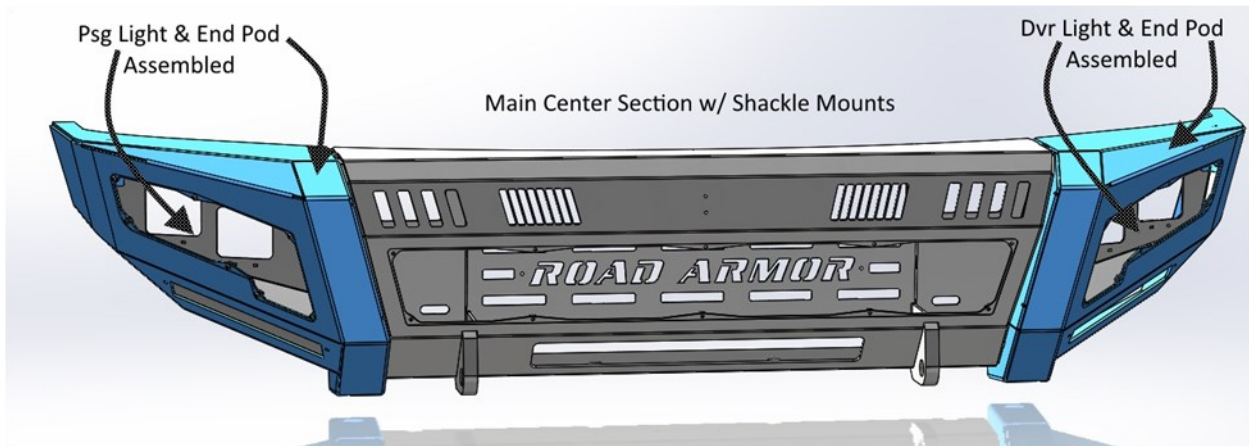
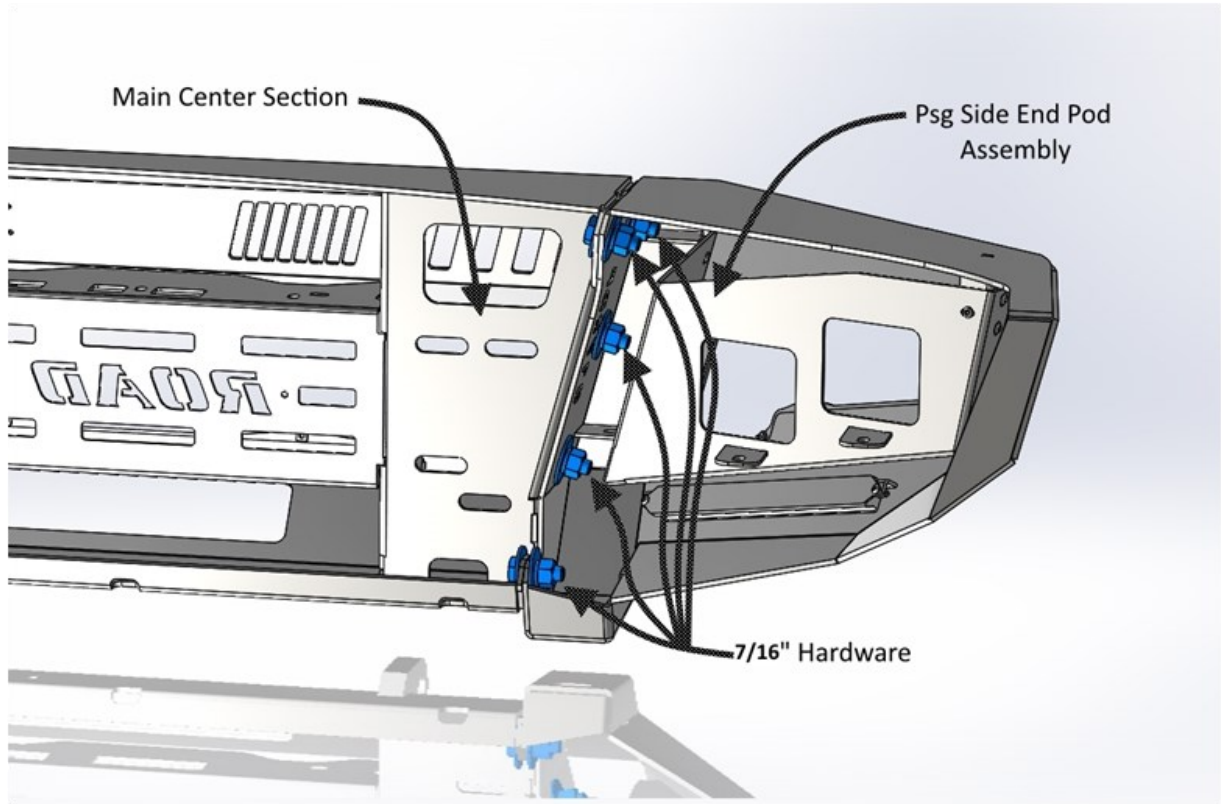

9 Install Kit Main Center Section "Logo Plate" using qty: 2 - #10-24x 1/2" Bolts & Lock Nut.

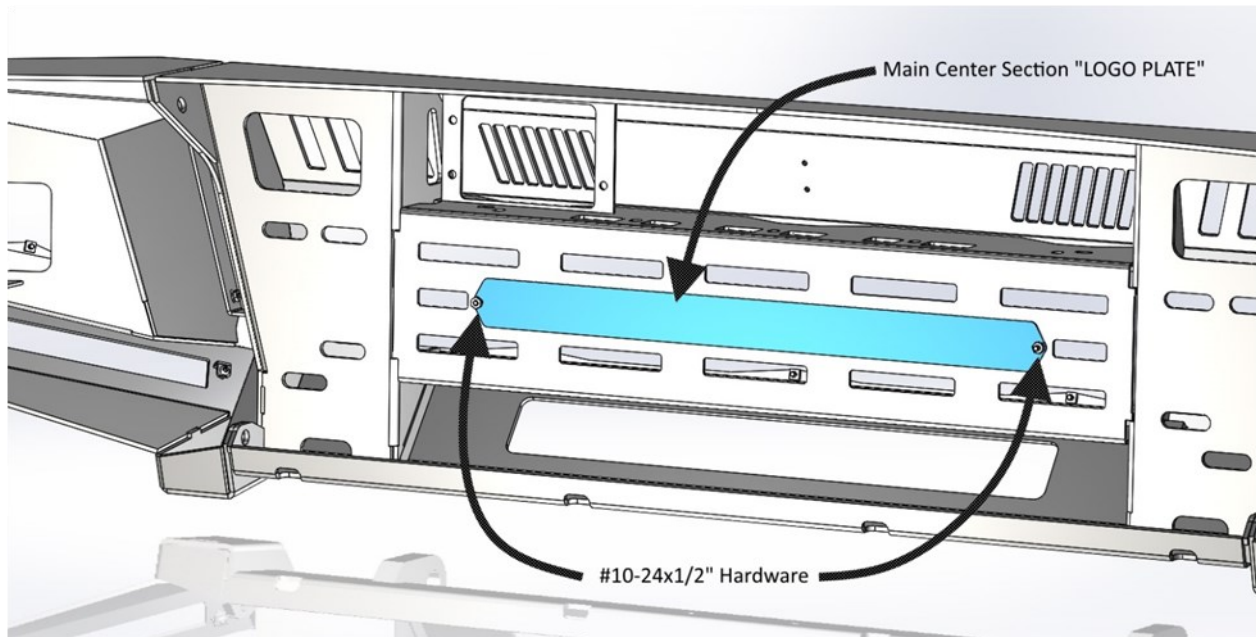

****ADDITIONAL STEP FOR SENSOR INSTALL****

Note: (When equipped) Install OEM GM Part # 23276812 (Park Sensor Housing/Purchased Separately), by pushing housing into main center section and end pods in the same position they were from factory. Continue by installing factory parking sensors into each sensor housing; finished by routing the sensor harness through the bumper and secure harness to bumper:

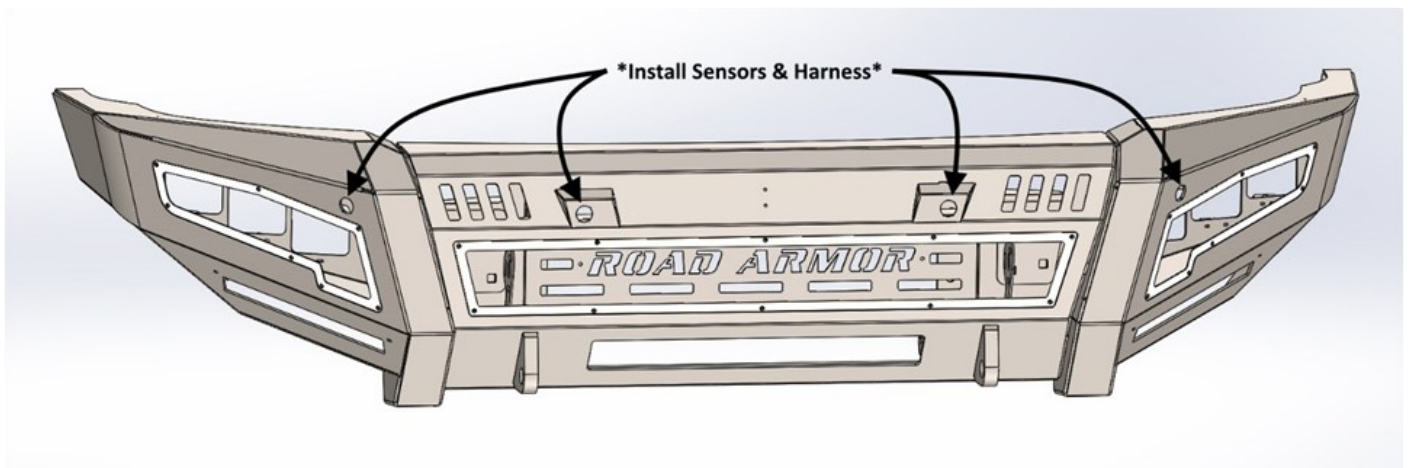

- 10** Install kit carriage bolt plate through front side of bumper using kit Qty: 4 – 1/2" Bolt & retainer washer on back side of bumper to secure each plate.

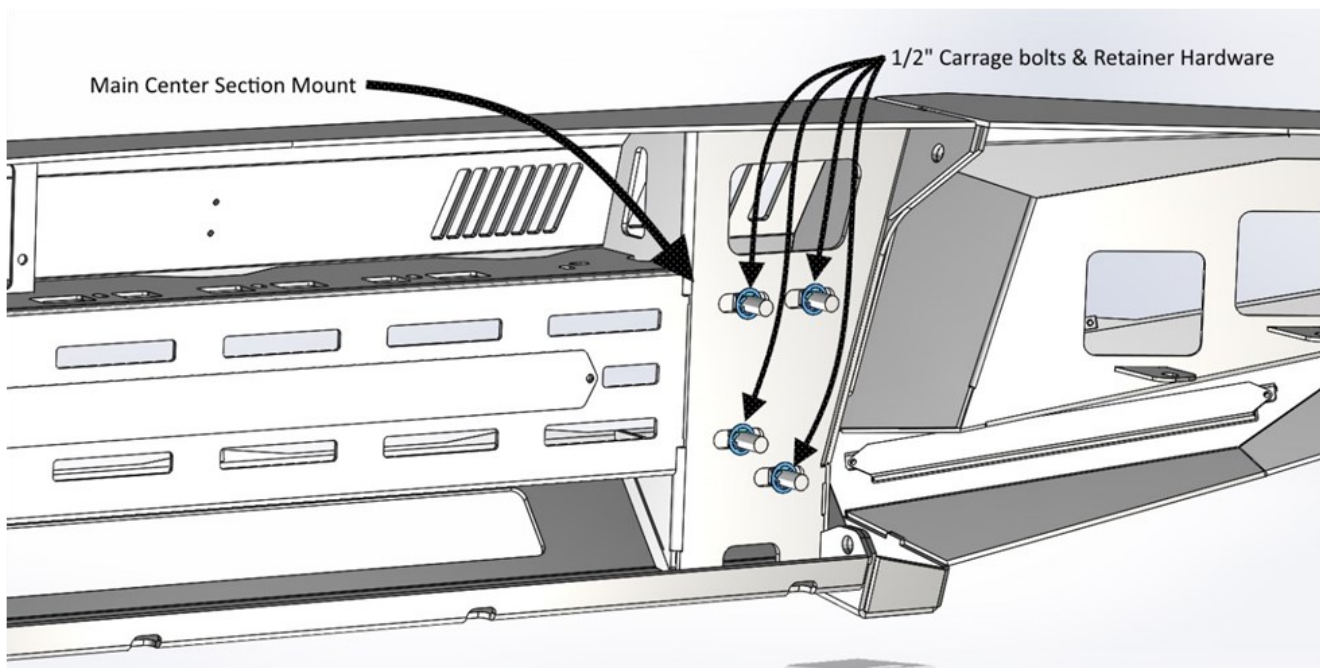
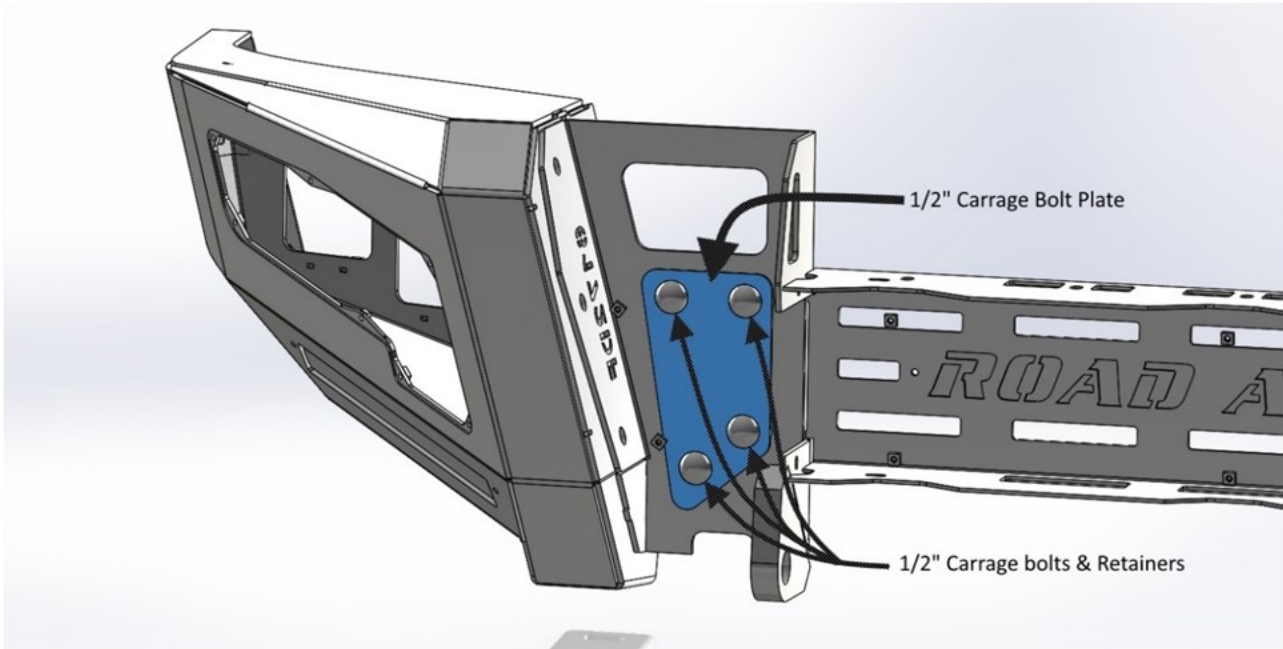

11 Install all lights and lighting brackets into kit main center section using kit brackets and 5/16 x 3/4" hardware provided as shown below (Check Lighting Configurations at End of Instructions). Install lighting into DVR & PSG Light Pods as well.

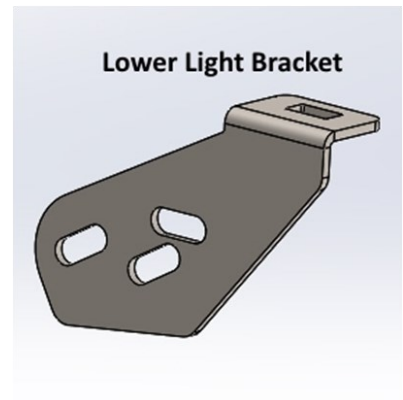
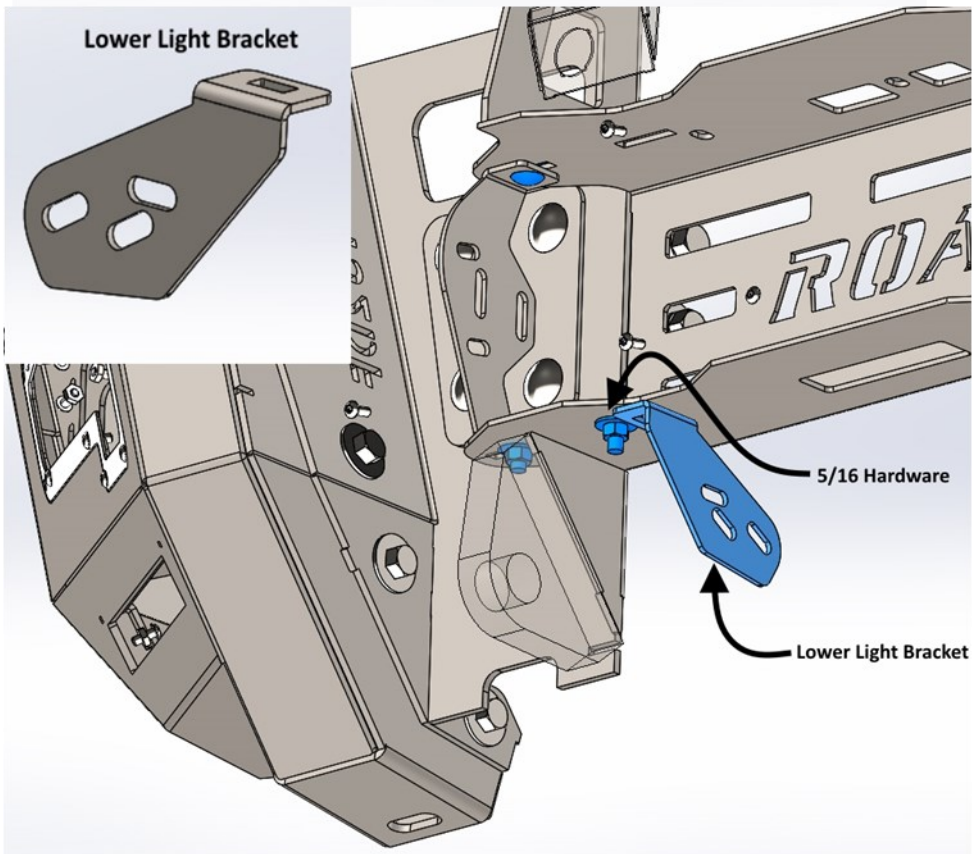
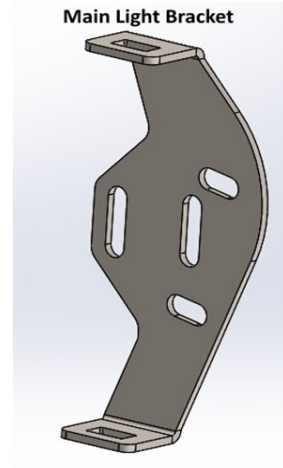
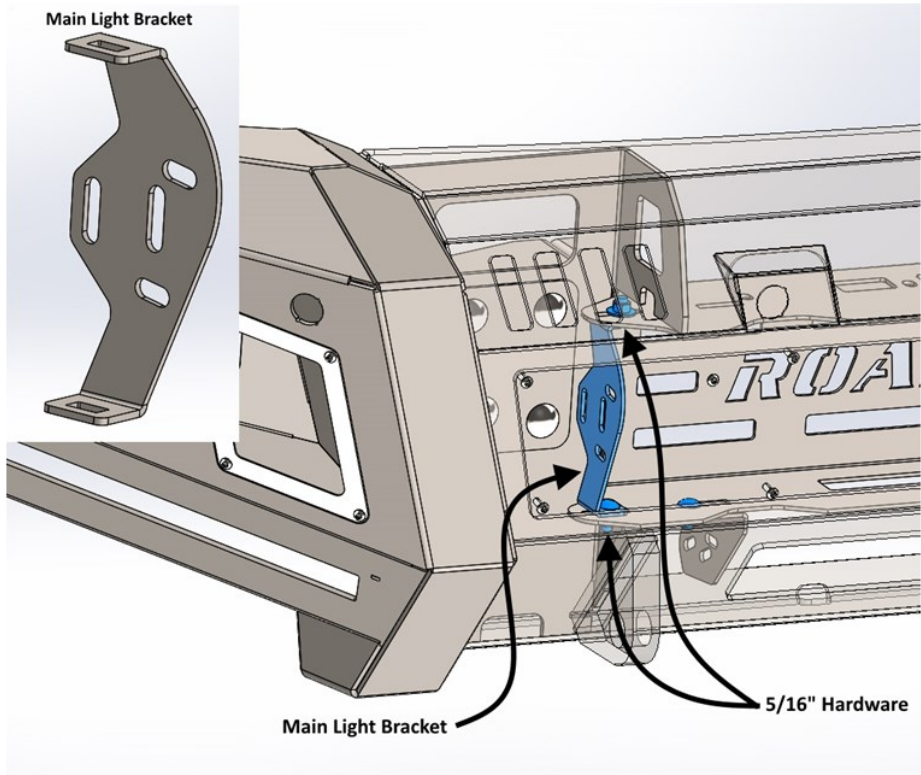

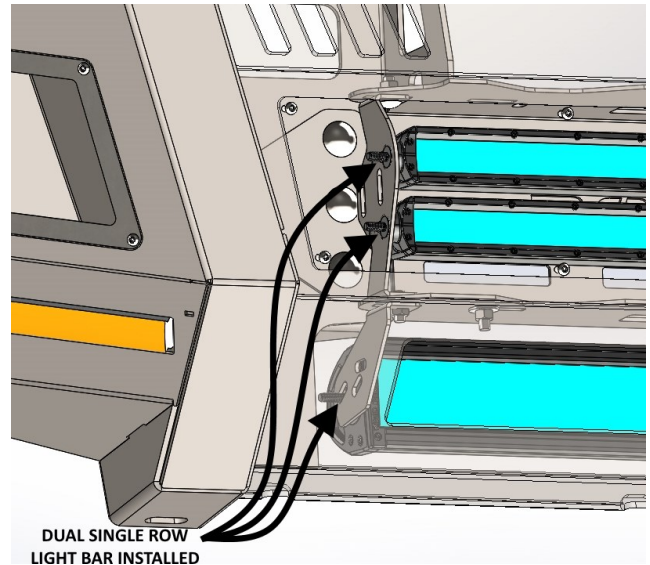
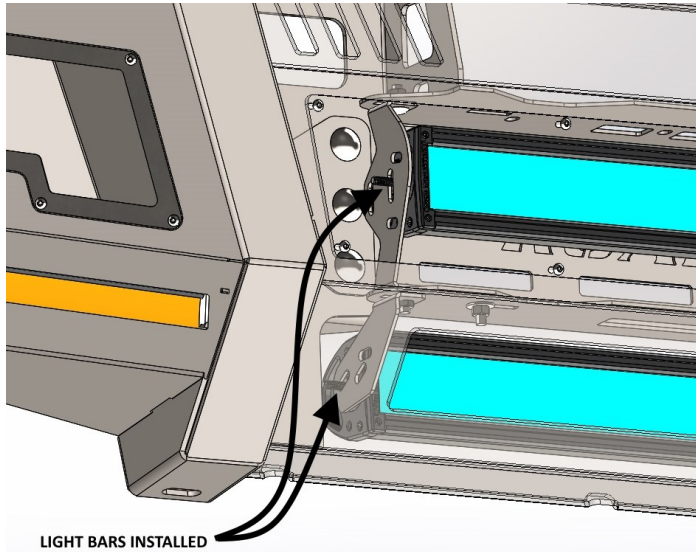

12

Install kit bumper bracket onto back side of bumper using kit Qty: 4 – ½” Bolt & retainer washer on back side of bumper to secure each bracket. (*Do NOT tighten bolts at this time*)

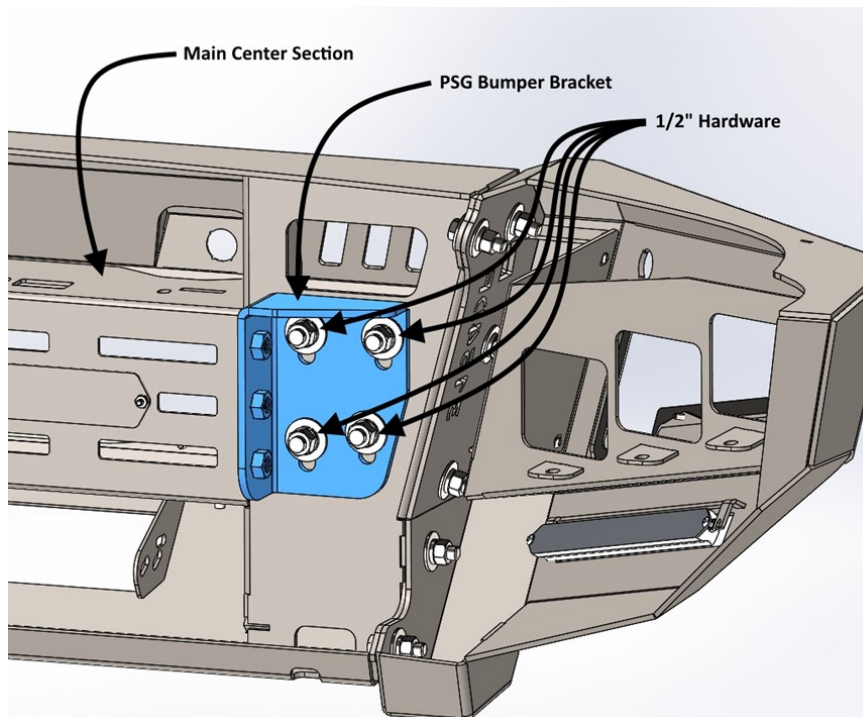

****NOTE: Be sure to remove grille assembly prior to installing iD front bumper. Doing so will allow easy access to kit ½” bumper bracket bolts during installation.****

****NOTE: If equipped with OEM horn, OEM horn will need to be relocated in engine bay or behind grill.****

- 13** Install kit frame brackets using Qty: 4 – FACTORY (OEM) 10mm Bolts through the front of each frame bracket. Continue by using Qty: 3 – 1/2" Bolt Tabs, Nuts, Lock Washers and Washers through kit bracket and lower frame where OEM tow hooks attached.

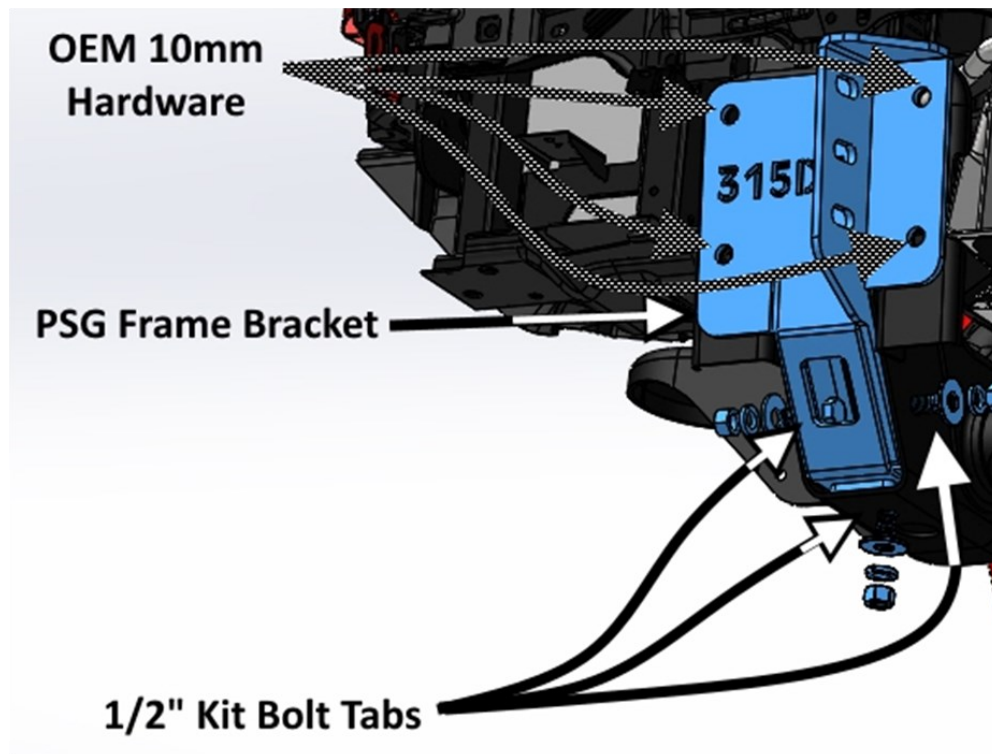

- 14** Before installing bumper be sure to clearance any core support sheet metal to accommodate different size lighting in kit light pods. Small amount of sheet metal may need to be removed before final install of bumper.

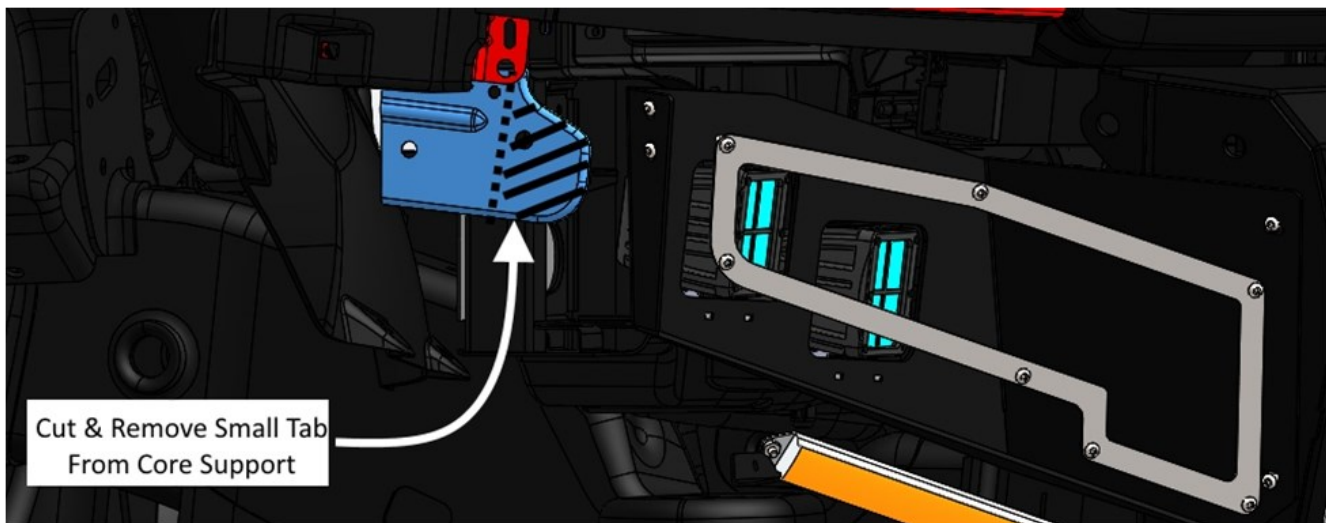

- 15** Install bumper assembly using kit Qty: 3 – ½” bolts, lock washers and washers at each frame end. Align bumper and be sure to leave approximately 3/8” gap between headlamp and bumper. (Doing so will prevent damage to headlamp and bumper.) Once bumper is aligned; tighten all remaining bumper bracket hardware.

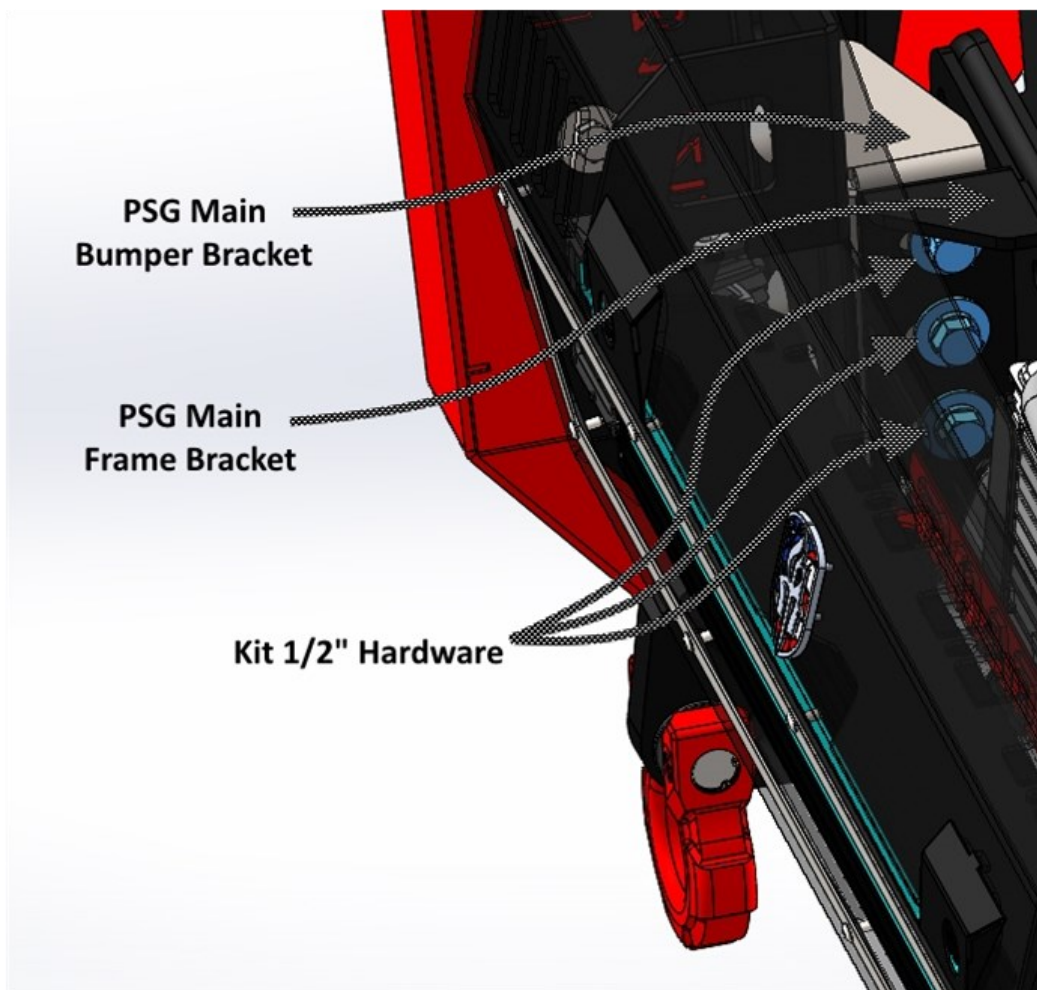

16 Install grille using Qty: 4 – FACTORY (OEM) bolts and lower clips at this time.

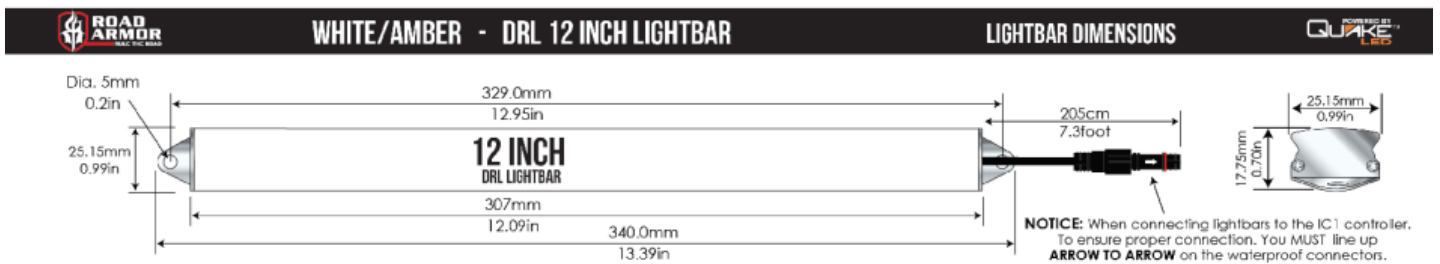
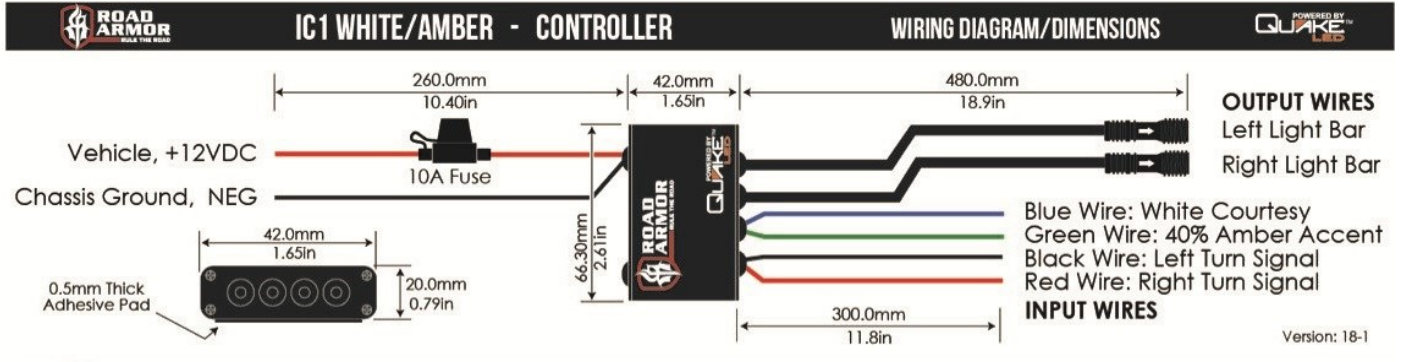

Center Configurations Shown Below:

(For all Identity Front Bumpers)





MESH KITS SHOWN BELOW:

