



Hills®

**Hills Folding
Frame
Double and
Single**

Product Manual



Congratulations

Congratulations on the purchase of your **Hills Folding Frame Clothesline**, which will bring you many years of trouble free and efficient drying.

Your Folding Clothesline can be either wall or post mounted. If you are planning to post mount, you will need to purchase a post kit (sold separately).

It's important that you read this Product Manual thoroughly before installation to benefit from the design features and enjoy safe use of this product.

Thank you for choosing Hills.

Patents and Registered Designs apply to this product.

Warning

- Do not allow children or pets to swing on your Clothesline or items of laundry.
- Ensure when raising and lowering your clothesline that bystanders (in particular children) are standing well clear.
- Do not use for any purpose other than to hang and dry washing.
- Do not use your clothesline if parts are worn or damaged.
- Do not allow the frame to lower in an uncontrolled manner as damage or injury may result.

Please retain this Product Manual. Record the following information for future reference.

Product Number (printed on carton): _____

Date of purchase: _____

Name and location of store: _____



Designed and tested under a Quality System that meets Hills demanding quality specifications.

Made in China

Carton contents

Check all components are supplied in your carton. Refer to the chart below for quantities.

	Folding Clothesline	Double	Single
1	Mount Bracket Assembly LH	1	1
2	Mount Bracket Assembly RH	1	1
3	Arm – LH	1	1
4	Arm – RH	1	1
5	Arm Inner – LH	1	–
6	Arm Inner – RH	1	–
7	Inner Spreader Bar	2	–
8	Outer Spreader Bar	2	2
9	Spreader Joiner	2	1
10	Corner	4	2
11	Line	2	1
	Hex Key 5mm	2	2
	Hex Key 4mm	1	1
	Line Tie Off Cap	4	2
	Fasteners*	4	4

*In the Double Folding Clothesline, the fasteners are located in the wall bracket assembly.

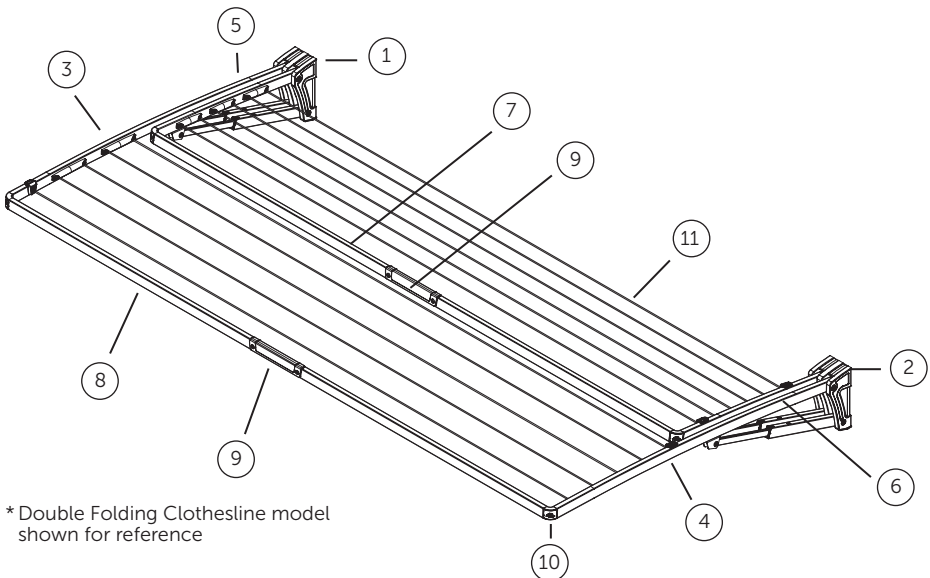

* Double Folding Clothesline model shown for reference

Step 1 – Select a suitable location

- Your Folding Clothesline can be mounted to either a wall or post kit (sold separately).
- You must check to ensure you have sufficient space in your garden / yard to install your clothesline. Refer **Fig. 1**.
- Your product can be reduced in width (if needed) refer to step 8 on page 12 for details.
- We recommend mounting your Folding Clothesline at a height approximately 50mm (2") above the head height of the intended user. Refer **Fig. 1**.

Fig. 1

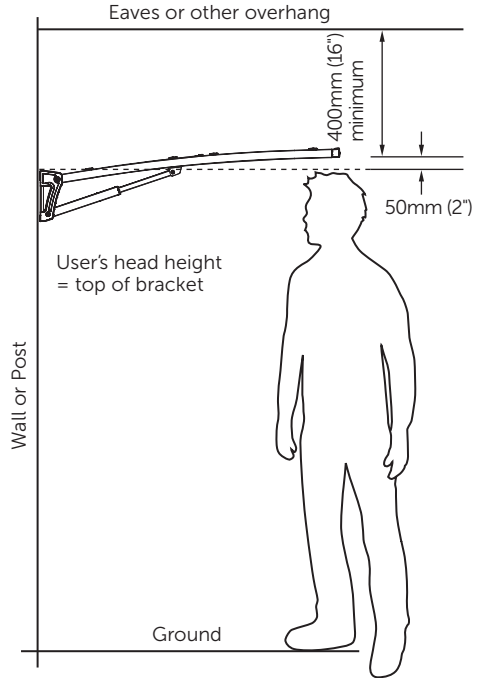
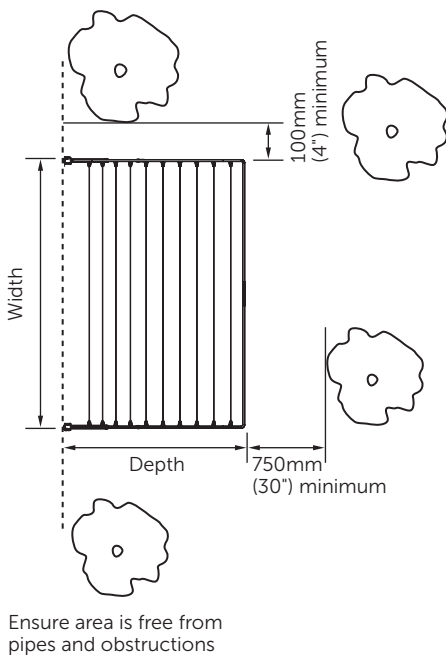

Product Dimensions

Product	Width	Depth
Double Folding Clothesline	2250mm (88.5")	1200mm (47.2")
Single Folding Clothesline	2250mm (88.5")	1200mm (47.2")

Step 2 – Installing your mount brackets

- Inserts will need to be removed in order to attach the mount bracket to your type of installation. Refer **Fig. 2**.

2.1 To remove the inserts, simply hold the moulding and pull out.

2.2 To re-attach, push the insert back into the bracket.

⚠ Warning: When installing the brackets for your Double Folding Clothesline, ensure the left and right labels are positioned correctly. There are stickers on the brackets that identify LH and RH brackets.

Fig. 2

Single Folding Clothesline

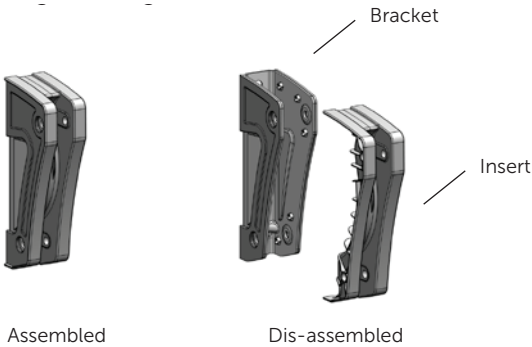

Double Folding Clothesline

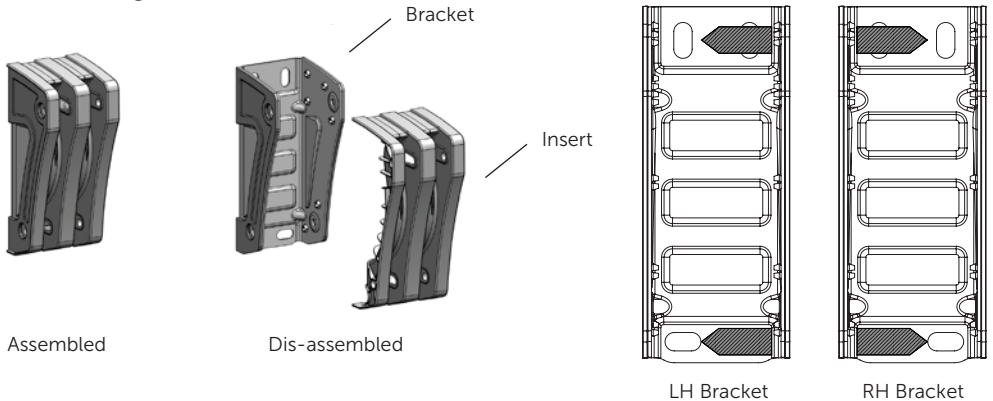

Step 3 – Installing your mount brackets

The following instructions are provided for installing your mount brackets to either;

- Brick or masonry walls (step 4)
- Stud walls (step 5)
- Post Kits (step 6)

 Due to the range of wall construction materials available, or if you have any doubt, consult your local hardware store.

 Install the left hand bracket first and use this to align the right hand bracket.

- Hold each bracket against the wall, making sure they are aligned vertically and horizontally, and use them as templates to mark where to drill holes, (a spirit level and straight edge will help).
- User's head height to equal top of bracket.

Fig. 3

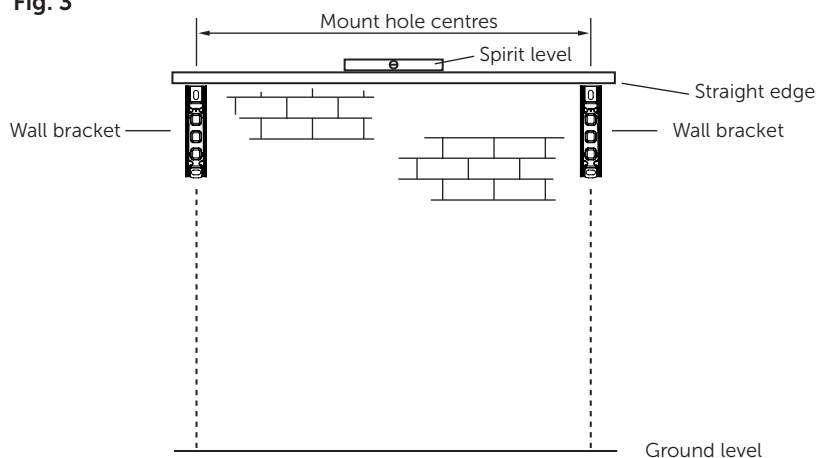

Refer to **Fig. 1**

Important: When installing a Double Folding Clothesline, take note of which holes are to be used for mounting of the mount brackets.

On the LH bracket, use the left holes. On the RH bracket, use the right holes.

Product	Mount Hole Centres
Double Folding Clothesline	2200mm (86.5")
Single Folding Clothesline	2200mm (86.5")

Step 4 – Fixing to a brick or masonry wall

- 4.1** Double check to ensure you have sufficient clearance and the area is free from pipes and other obstructions.
- 4.2** Mark the position of the mount bracket hole centres on the wall.

 If you are replacing an existing Hills Folding Frame product using the original fasteners, ensure they are suitable and still in good condition.

For sound brick/masonry walls, we recommend using appropriate flush head 10mm diameter fasteners.

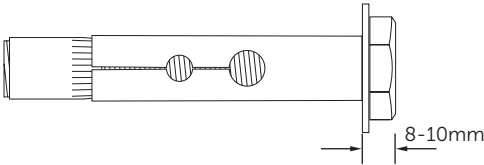

Ensure the head of the bolts do not protrude more than 8-10mm.

- 4.3** Drill appropriately sized holes in your wall to suit the fasteners being used. Refer **Fig. 4**.
- 4.4** Clear holes of dust and debris before inserting fastener. Refer **Fig. 5**.
- 4.5** Check the left hand and right hand bracket orientation, then insert fasteners and secure.

Fig. 4

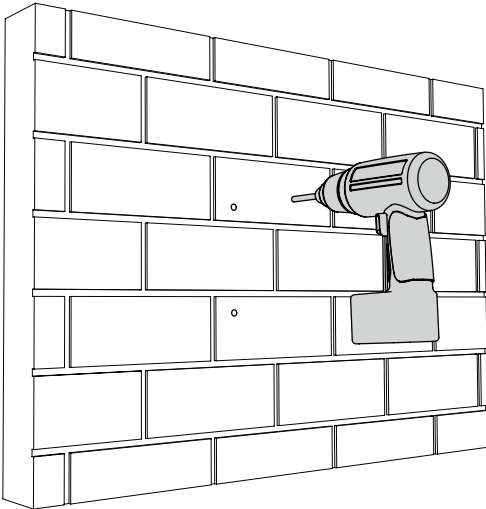
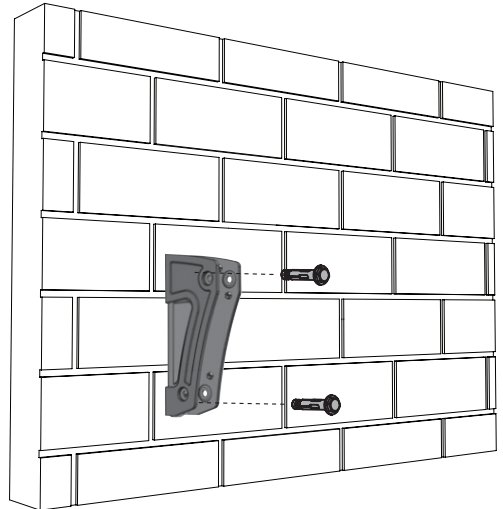

Fig. 5



Mount bracket
Single shown here

Step 5 – Fixing to a stud wall



- 5.1** Double check to ensure you have sufficient clearance and the area is free from pipes and other obstructions.
- 5.2** Locate the vertical studs in your wall.
- 5.3** Determine if you need to adjust your product width.
-  You may need to reduce the width of your Folding Clothesline to match existing stud centres, (refer to step 8 on page 12 for details).
- 5.4** Mark the position of the mount bracket's hole centres on the wall (corresponding with the stud positions). Refer **Fig. 6**.
- 5.5** Drill the correct size holes in your wall to suit the fasteners being used.
- For timber stud walls we recommend using four 8mm (5/16") x 75mm (3") long wood screws.
 - For other stud and wall construction materials we recommend you consult your local hardware store for the appropriate fasteners.
 - When drilling into timber studs, always drill a pilot hole to reduce the chance of the studs splitting.
-  It is critical that your Folding Clothesline mount brackets are securely fastened to the vertical studs in your wall. Appropriate fasteners must be used, strong enough to support full loads of wet washing.

Fig. 6



Step 6 – Fixing to a post kit

Post kits for Folding Clotheslines are available as optional accessories.

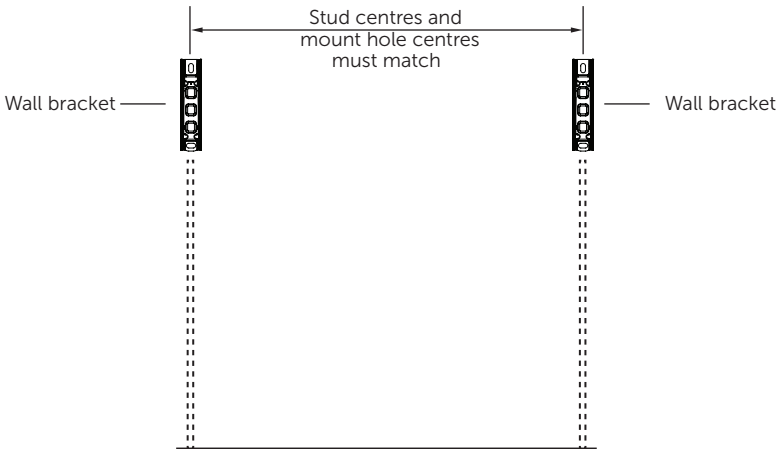

6.1 Install and assemble the post kit as per the separate instructions provided with the kit.

6.2 Install the mount brackets as shown. Refer **Fig. 7**

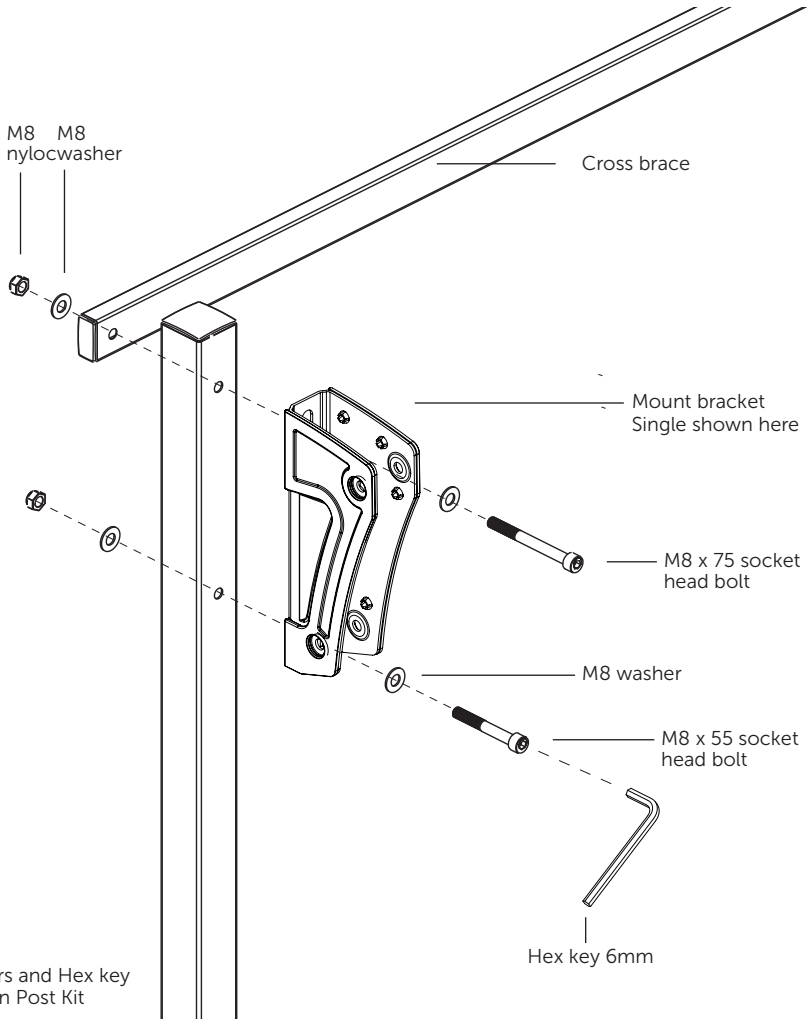
Fig. 7



Step 7 – Assemble the spreader bars

-  On the Folding Frame Mono ensure the spreader bars are assembled in the correct orientation (**Fig 8**).
- 7.1** Dis-assemble the spreader handle from the spreader joiner using the hex key 4mm. Refer **Fig. 8**.
-  Insert the spreader joiner into the spreader bar and then fasten with the spreader handle as shown. Refer **Fig. 9**.
- 7.2** Once the Joiner has been assembled to the first Spreader, fasten one of the screws to prevent the Joiner slipping in further during the assembly of the second Spreader.
-  **You must ensure the correct orientation of the spreader bars, spreader joiner and mount holes.**
- The spreader joiner is designed to be a tight fit within the spreader bar so you may need to gently 'tap' it in with a hammer. Ensure you protect the other end of the spreader bar with a cloth, soft surface or the cardboard packaging to avoid damage.
 - Ensure the mount holes and fasteners align.
 - If you accidentally insert the spreader joiner too far you can 'lever' it out using a screwdriver. Refer **Fig. 10**.

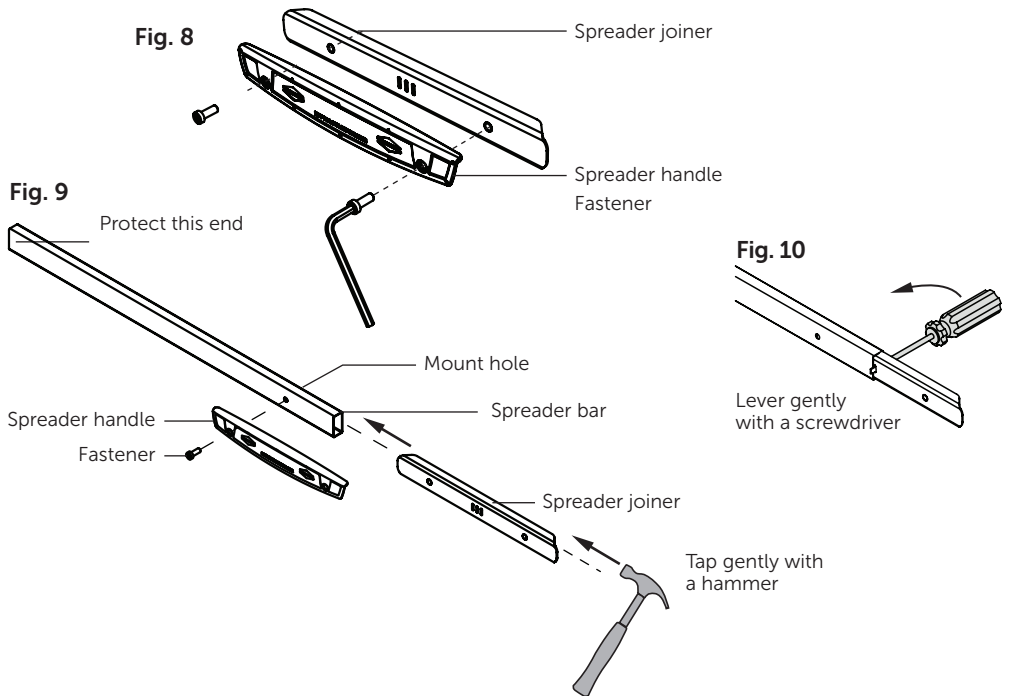

Step 7 – Continued

7.3 Assemble the second spreader bar and secure the fastener.

Again you may need to tap the end gently with a hammer as it's designed to be a 'tight' fit. Refer Fig. 11.

Fig. 11

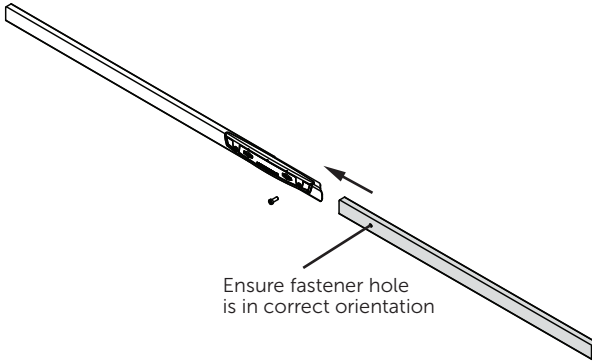

Double Folding Clothesline

The Double Folding Clothesline has an outer (longer) and inner (shorter) spreader bar. Refer Fig. 12.

 You must ensure the lengths of spreader bars match.

Fig. 12



Step 8 – Adjusting the width of your Folding Clothesline

- Your Folding Clothesline width can be reduced to suit your specific installation needs or to align with existing stud centres.
- The standard mount hole centres for your Folding Clothesline model are shown in the table on page 6.
- Determine the length you need to reduce your product, halve this amount and cut equal lengths from the ends of the assembled spreader with a hacksaw. Refer **Fig. 14**.

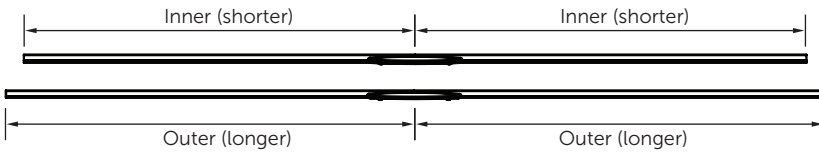

For the Double Folding Clothesline model, you will need to cut both the inner and outer assembled spreader bars

- Cutting equal amounts from each end of the spreader will maintain the spreader handle in the centre of the product.
- Be careful when cutting with a hacksaw, ensure you do not slip/damage the powdercoat and keep the cut edge square. You may need to clean up the edges with a file after cutting.
- Make sure the inside of the cut edges are smooth to allow the corners to slide in easily.

Fig. 14

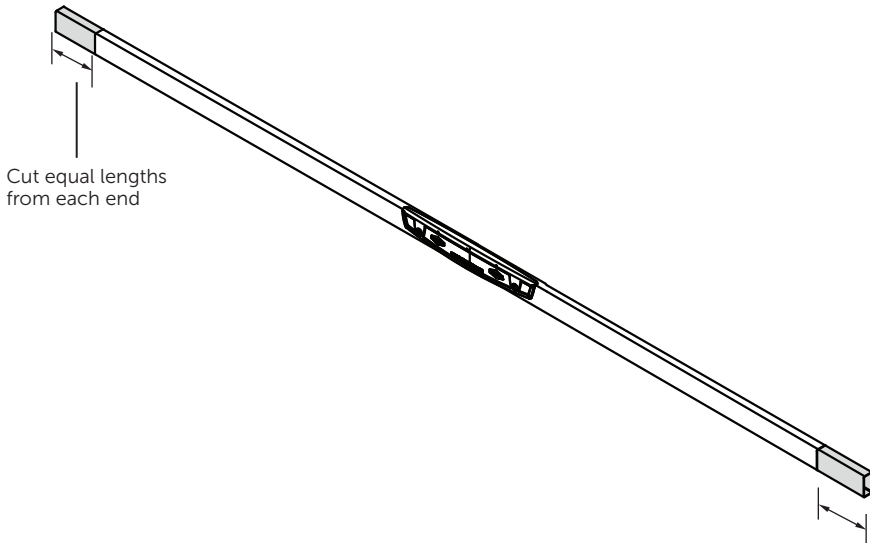

Step 9 – Fit arms to mount brackets

9.1 Re attach plastic inserts into wall brackets.

9.2 Attach the arms to the top of the mount brackets as shown using the fasteners and 5mm hex key provided. Refer to **Fig. 15** and **Fig. 16**. Replace arm end cap if it has come loose in transit. Refer to **Fig. 17** for correct orientation.

9.3 Attach the struts to the bottom of the mount brackets as shown using the fasteners and 5mm hex key provided. Refer to **Fig. 15** and **Fig. 16**.

⚠ Do not over tighten the fasteners as the arms and struts must be free to pivot.

📄 In this manual left and right side is referenced as if you are looking at your clothesline ie. at the wall/post kit you are assembling to.

Repeat for other arm.

Fig. 15 Single Folding Clothesline

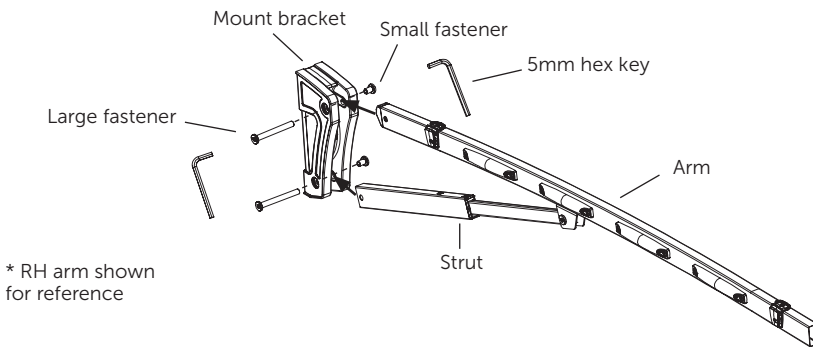
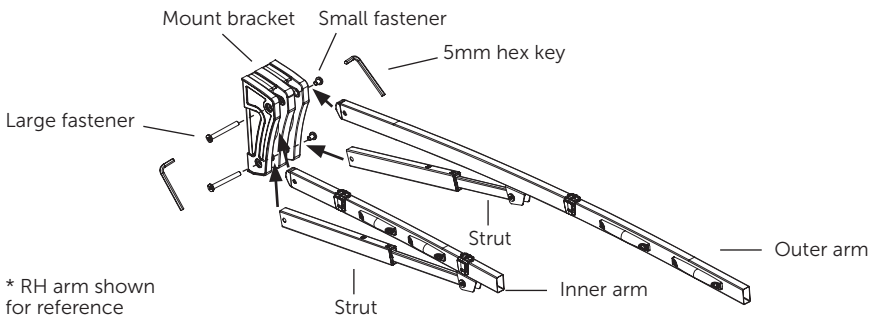

Fig. 16 Double Folding Clothesline



Note: Arms to fit into mount bracket long arm on the outer, short arm on the inner.

Step 10 – Assemble corners into spreader bar

10.1 Remove corner caps by gently levering with a screwdriver. Refer **Fig. 18**.

10.2 Insert and secure the corners into both ends of the spreader bar using hex key 5mm (ensure bolts are firmly tightened). Refer **Fig. 19**.

Fig. 18

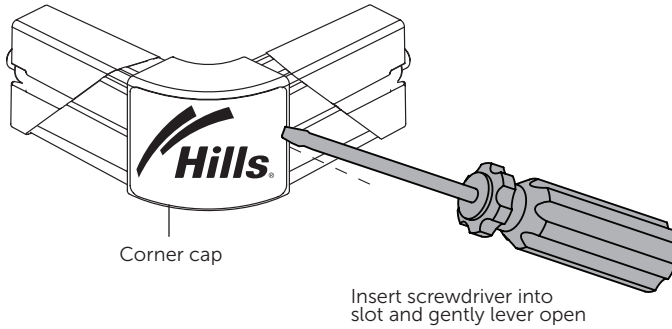
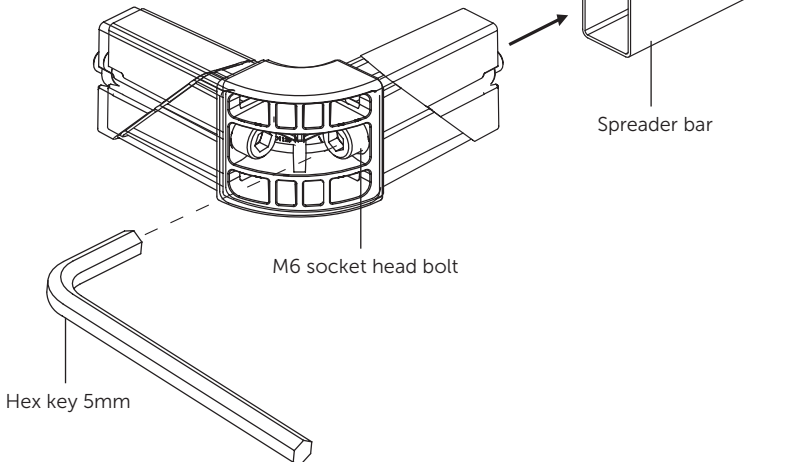

Fig. 19



Step 11 – Assemble spreader bar to arms

- 11.1** Lift and rotate each arm up until the strut clicks once to indicate it has engaged, then lower gently to the 'horizontal' position. Refer **Fig. 20**.
- 11.2** Insert the spreader bar and corners into the arm ends and secure using hex key 5mm. Refer **Fig. 21**. Please note the correct handle orientation.
- 11.3** Snap on all corner caps with Hills logo up **Fig. 22**.

Fig. 20

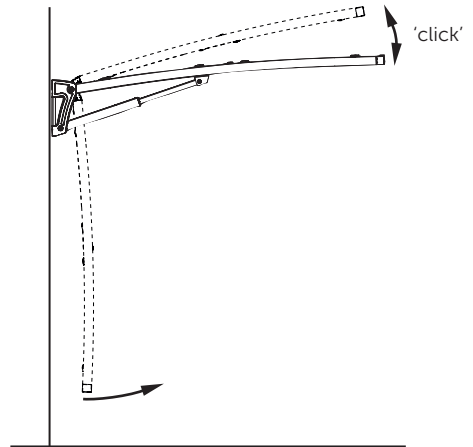

Fig. 21

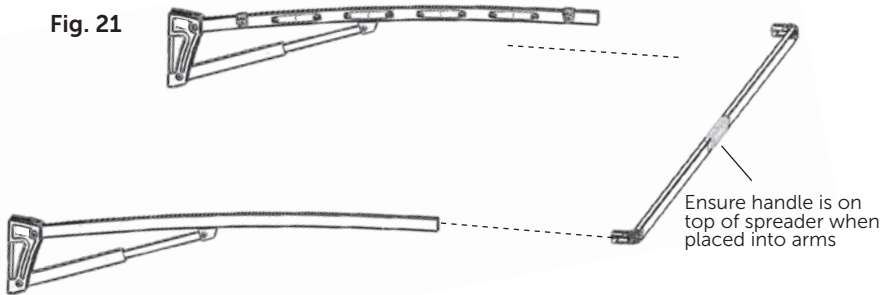
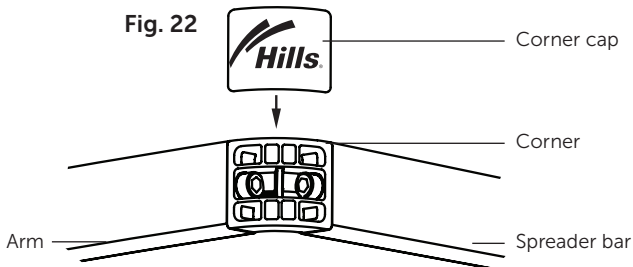

Fig. 22



Step 12 – Attaching the line

- Each Folding Clothesline product has individual line configurations and threading patterns, as shown. Refer **Fig. 23**.
- Each line is fastened to a line tie-off, then threaded through the line sleeves and tensioned/ fastened to the other line tie-off.

Fig. 23

Single Folding Clothesline

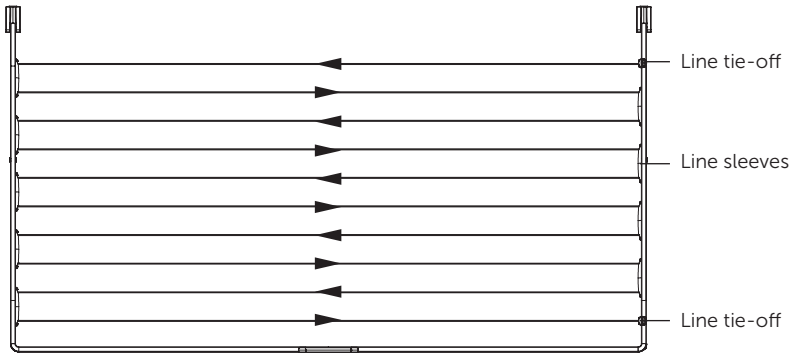

Double Folding Clothesline

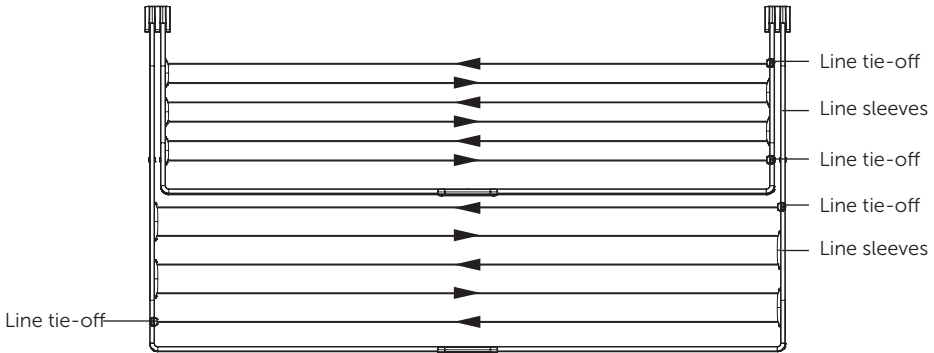

Step 12 – Continued

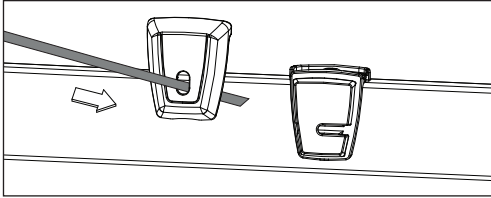

12.1 Thread a line tie off cap onto one end of the PVC line.

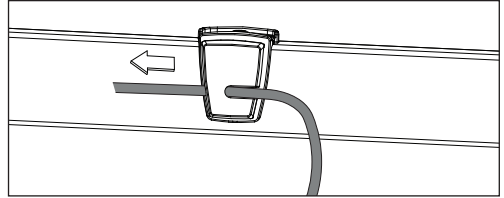

12.2 Insert the line into the slot of the line tie off saddle and through the side. Pull through 15cm+ of excess line for tensioning.

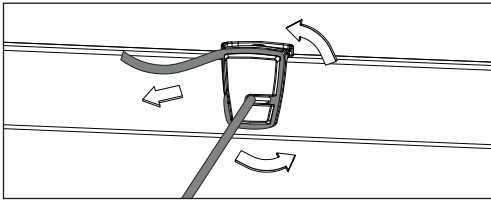

12.3 Loop the line around the groove in the line tie off saddle. Pull tight to prevent the line from slipping.

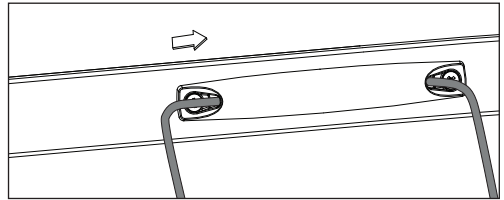

12.4 Feed the line through the line sleeves, starting with the rear sleeve on the other arm.

 Note It is useful to kink or twist the line when feeding it through the line sleeves to make assembly easier.

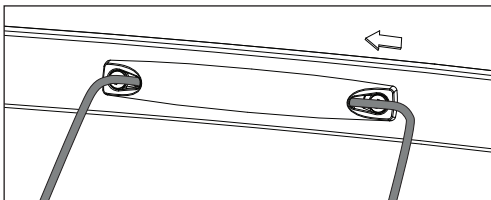

12.5 Continue feeding the line through the line sleeves ensuring all lines are parallel (refer to **Fig. 23** for the threading pattern for your product).

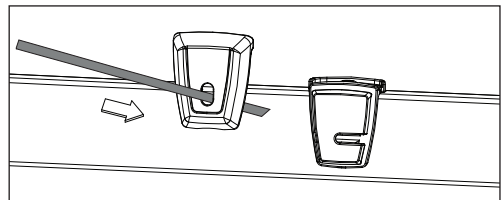

12.6 When you reach the tie off end of the line, thread another line tie off cap.

Step 12 – Continued

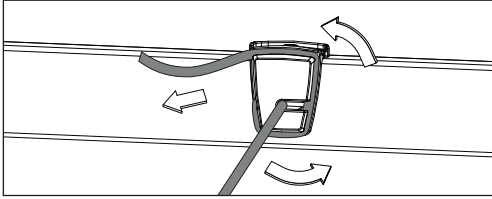

12.7 Insert the line into the slot of the last line tie off saddle, repeat the tie off.

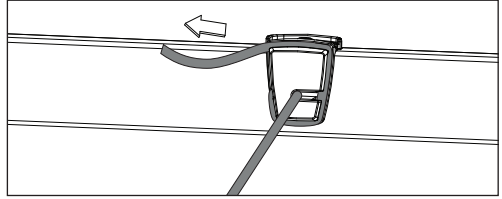

12.8 Check that all the lines are tight and adjust and retension if necessary.

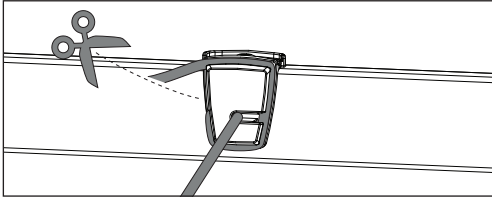

12.9 Trim off excess PVC line at dotted line shown above. Make sure line is firmly pulled back into the line tie off saddle.

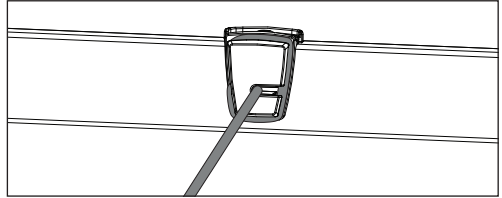

12.10 Push PVC line end securely into saddle.

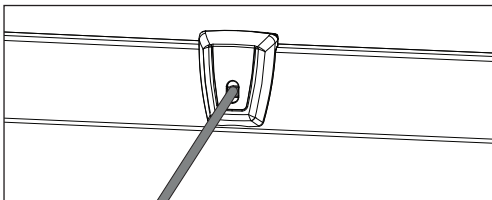

12.11 Fit line tie off caps over the line tie off saddles.

Step 13 – Using your Folding Clothesline

To lower the clothesline (Fig. 24)

- Loosely grip the spreader bar handle.
- Raise the frame until you hear both struts 'click' once to indicate they have disengaged.
- Now lower the frame gently to its folded position.

To raise the clothesline (Fig. 24)

- Loosely grip the spreader bar handle.
- Pull the frame away from the wall slowly and raise it above your head until you hear both struts 'click' once to indicate they have engaged.
- Now lower the frame slightly – if both struts have fully engaged, the frame will be supported squarely.
- If the struts did not engage on both sides repeat the process.

Fig. 24

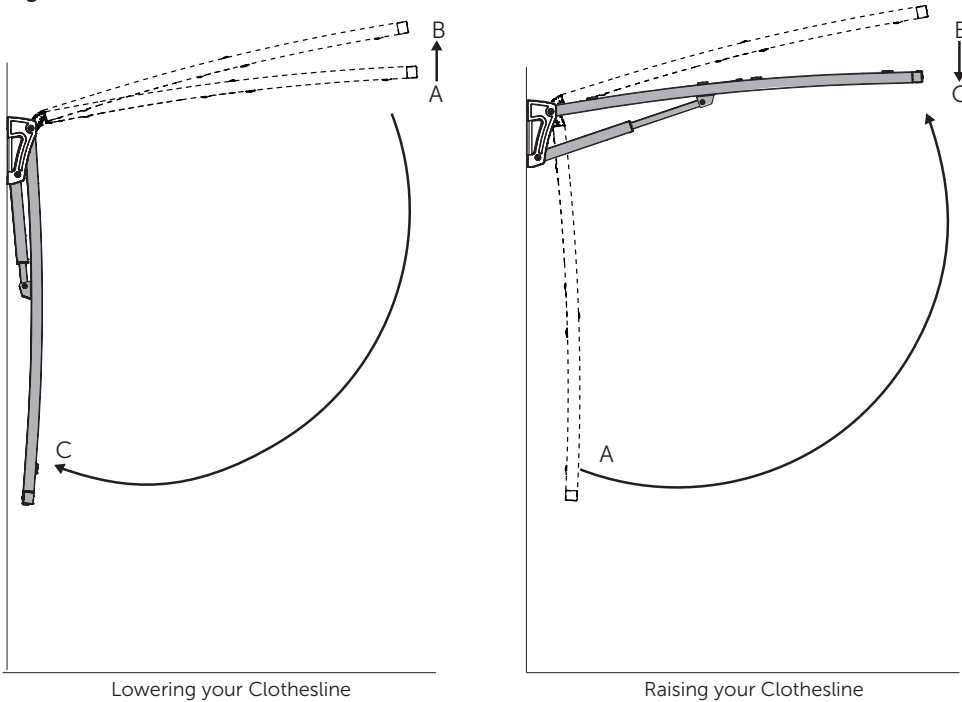

Care and Maintenance

Regularly inspect all components and check for wear and tear or damage. Ensure fasteners are secure. If there is any damage, parts should be replaced with original Hills spares. The Clothesline should be repaired before using again.

Your Clothesline should be periodically wiped clean with a damp cloth and mild detergent.

Your Clothesline should be easy to operate, but if left for a period of time it may become more difficult. It is recommended that the clothesline is raised and lowered regularly.

We do not recommend the use of oil or 'WD' type lubricants on any part of the Clothesline.

Wipe away any dirt and dust from the telescopic struts with a damp cloth once a month. More regularly in dusty conditions.

To maintain appearance and durability of coating on metal components we recommend a twice yearly application of a reputable brand of car polish or wax.

Line Tensioning

To remove any excess 'slack' from the lines, feed the line through the Line Sleeves until desired tension is achieved. Undo and re-tie line as shown in step 12 on pages 17 and 18.



Do not over tension the line as you may distort the frame.

Hills Handy Hints

- Place smaller items of clothing on the lines nearest to the wall or posts and work your way outwards for larger items.
- When you do not expect to fill the capacity of your clothesline, hang your clothes on the outer lines, as this will allow clothes to dry more easily.

10-Year Warranty*

*In addition to other rights and remedies that may be available under any applicable law, Cyclone Tools Pty Ltd warrants to the purchaser of the product (customer) that this Clothesline will be free from defects in workmanship and materials for 10 years and the Polycore Line for 1 year from the date of purchase of the product. If a defect in material or workmanship becomes evident during that period, Cyclone Tools Pty Ltd will, at its option, either:

- replace the product; or
- refund to the customer the purchase price paid by the customer for the product.

In the event of such a defect, the product should be returned to the place of purchase of the product by the customer, together with proof of purchase, for replacement or refund. Any handling and transportation (and other expenses incurred in claiming under this warranty) are not covered by this warranty and will be borne by the customer, not Cyclone Tools Pty Ltd.

The obligation of Cyclone Tools Pty Ltd under this warranty is limited to the circumstances set out above and is subject to:

- the product not having been altered, tampered with or otherwise dealt with by any person in a manner other than as intended in respect of the relevant product; and
- the product not having been used or applied in a manner that is contrary to customary usage or application of the relevant product or contrary to any stated instructions or specification of Cyclone Tools Pty Ltd (or its related bodies corporate).

For products purchased in Australia:

Our goods come with guarantees that cannot be excluded under the Australian Consumer Law. You are entitled to a replacement or refund for a major failure and compensation

for any other reasonably foreseeable loss or damage. You are also entitled to have the goods repaired or replaced if the goods fail to be of acceptable quality and the failure does not amount to a major failure.

For products purchased in New Zealand:

Our goods come with guarantees that cannot be excluded under the Consumer Guarantees Act. Cyclone Tools Pty Ltd will comply with our obligations to you under the Consumer Guarantees Act.

Cyclone Tools Pty Ltd
ABN 89 169 427 061
Level 1, 660 Doncaster Road,
Doncaster Vic 3108
Phone: 1300 300 564
Email: hhl.enquiries@amesau.com

Hills Contacts

We are committed to providing you with complete customer satisfaction. If you have any questions or comments about our products or services please contact your nearest Customer Service Centre during their local business hours:

Australia

1300 300 564

New Zealand

0800 021 027

Email

hhl.enquiries@amesau.com

Hills Websites

hillshome.com.au

Hills Home Living

hillshome.com.au/need-help/

Hills Consumer Advice

Cyclone Tools Pty Ltd
A.B.N. 89 169 427 061
Issue May 2017
HD10675c

