

Air Dry
clotheslines



Twin Fold Clothesline

Assembly instructions

Air Dry

clotheslines

Air Dry Clotheslines

Thank you for purchase of our *Twin Fold* clothesline. We hope this clothesline fulfils your laundry needs and continues to remain of benefit to you and your family.

This manual includes a set of assembly instructions along with a user guide. Please thoroughly read through these to acquaint yourself before starting the assembly and use of the clothesline.

Assembly instructions

Step 1: Open packaging and check off contents

Do **NOT** open the arm assembly until it is mounted on the wall/ posts

Assembly Parts:

- A. 1 x Left Arm Assembly
- B. 1 x Right Arm Assembly
- C. 2 x 750 arms
- D. 2 x Long Spreaders
- E. 2 x Short Spreaders
- F. 2 x Small Joiners (<2400 width clotheslines only)
- G. 2 x Large Joiners (3000 width clotheslines only)
- H. 2 x Cord bundles
- I. 4 x Wall Plugs

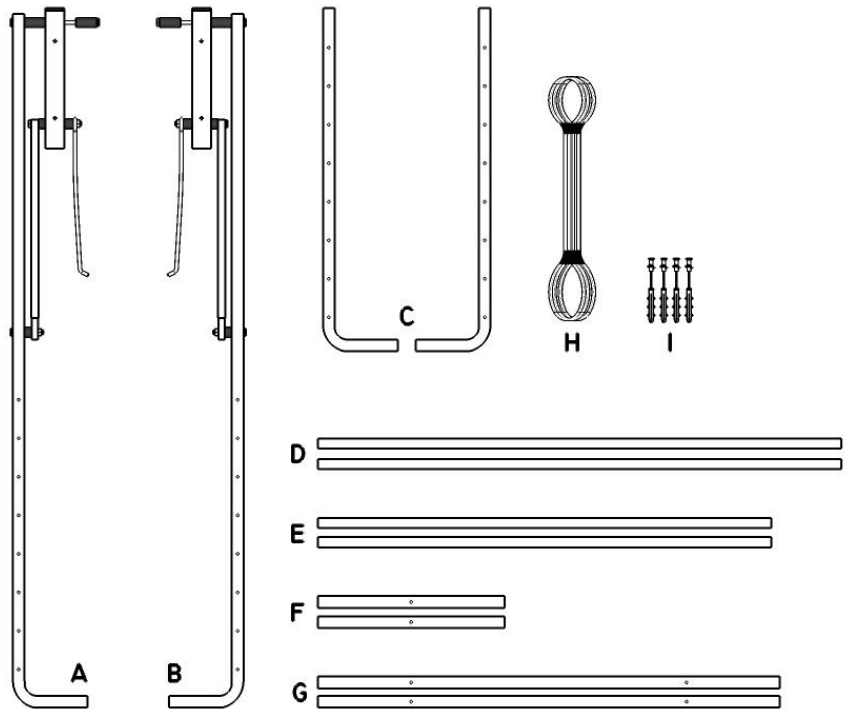

Tools required:

- Masonry Drill – 10mm bit
- 13mm spanner
- Tape measure
- Marker
- Spirit level
- Cord cutters

Air Dry Clotheslines are designed to be installed onto **masonry** walls only. **Not** to be installed onto weatherboard walls, cladding or timber walls. **Not** recommended for installation onto fencing. Ground Mount Kits are available for these installations.

Soft surface recommended for assembly to avoid scratches.

Step 1: Layout

To determine the clothesline height, add 100-150mm to the height of the user.

Formula to find the bracket hole centres – using the overall width of the clothesline ordered, **subtract** 140mm and this will give you the distance between the wall bracket **hole** centres. (For example, for a 2400 clothesline the holes should be 2260mm apart.)

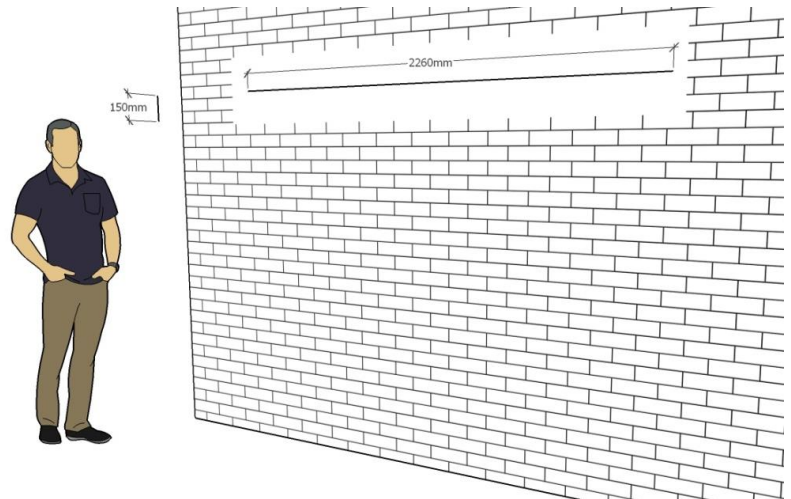

Use the tape measure and **mark** the location for the first wall bracket hole. From this mark, using the hole centre measurement, measure across the wall and mark the wall for the second wall bracket.

Make sure to leave a 100mm clearance on the outside of the wall brackets.

Do not drill holes into mortar.

Step 2:

Using a 10mm masonry drill bit, drill approximately 50mm into the wall at both marks



Step 3: Assembly

Place the arm assemblies on the ground with the wall side sticker facing the ground. Undo the nut at the top of the assembly and thread the 750 arm onto the bolt. Make sure the arm is facing the same direction as the outer 1500 arm. Secure with the nut. Tighten with the 13mm spanners. Complete this on both assemblies.

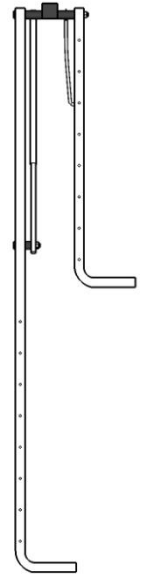

Step 4:

Push the orange wall plug through the top hole of the first wall bracket. Make sure the **wall side** sticker is facing the wall. Approximately 40mm will be visible out the rear of the bracket. Place this into the first drill hole on the wall. Tighten using the 13mm spanner.

Note: Do not insert the wall plug directly into the wall. It **must** go through the bracket first.

Step 5:

Using the spirit level, make sure the bracket is vertically level and adjust if necessary.

Once level, insert the 10mm masonry drill bit through the wall bracket's **bottom** hole and drill into the wall approximately 50mm. Push the orange wall plug through the bottom hole as before and secure with the washer and screw. Repeat these steps to attach the remaining arm assembly to the wall.

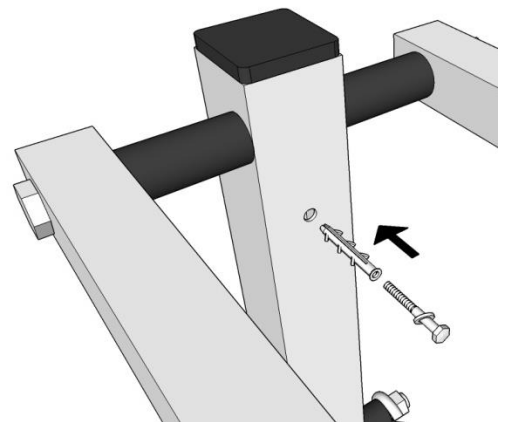

Step 6: Assembling the front bars

Inner frame: Place the small spreaders on the ground. Insert the 2 spreaders into each end of the joiner to make one long bar. Place each end of the bar into the ends of the 750 inner frame arms.

Outer Frame: Place the large spreaders on the ground. Insert the 2 spreaders into each end of the joiner to make one long bar. Place each end of the bar into the ends of the 1500 outer frame arms.

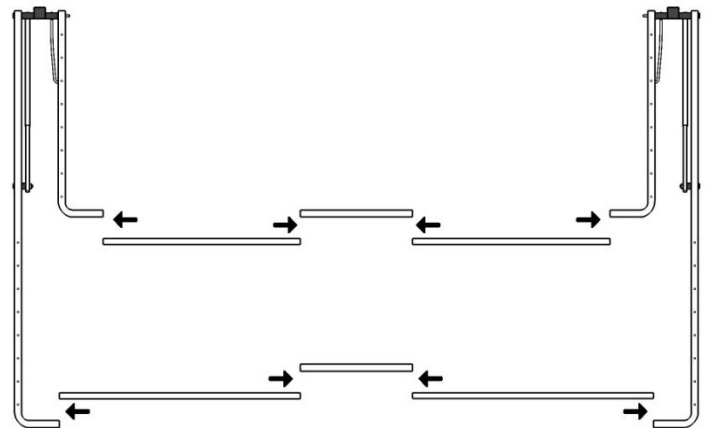

Step 7:

Lifting and lowering the **inner** frame: Lift the front bar and insert the inner stay into the hole of each arm.

Lifting and lowering the outer frame: Lift the front bar evenly from the **centre** slightly past horizontal until you heard both struts click and engage. Gently release the front bar. To disengage the struts and lower the frame, lift the bar evenly from the **centre** until both struts click and lower the frame.

Please note, if the front bar is lifted in an uneven manner, both struts will not engage. If this happens, reset by disengaging the strut and lower the frame. Start the process again, making sure to place your hands directly in the **centre** and lifting evenly.

Warning: Do not continue to lift the bar past the engaging point (struts clicking) as this will break the strut mechanism and a new strut will be needed at the cost of the consumer.

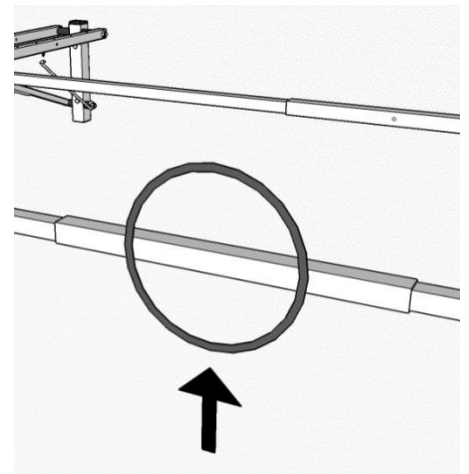

Step 8: Wiring

Parts Required:

- 2 x bundles of cord
- Scissors or wire cutters (not supplied)

Unravel the bundle of cord.

Take one end of the cord and thread the cord up through the first hole at the front of the arm. You may start from either side. Leave 300mm at the start for tying off on completion.

Bring the cord across to the opposite arm and thread it down the corresponding hole. Thread it back up the second hole next to it and bring the cord across to the opposite arm and down the second hole. See figure 8a. Repeat this process until all holes have been occupied leaving 300mm at the end for tying off on completion.

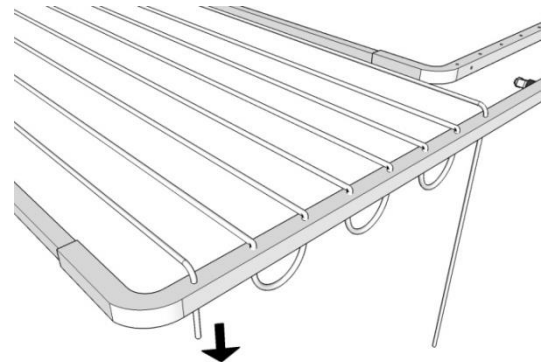

Once all holes have been threaded, bring each end of the cord around from the bottom of the frame, around to the outside of the frame. Place the cord under the previous line of cord and bring back to the outside of the frame to create an anchor tie off point. See figure 8b.

Starting from the front of the clothesline, place your hands in the centre of the first cord and pull downwards to remove slack out of the line.

Repeat this process on every line of cord. When you have tightened the last cord, release the end anchor tie off point and re-tighten.

Repeat this process for further tensioning. Once you are happy with the tension of the cord, complete both anchor tie off points with 2 x half hitch knots.

Cut off the remaining cord using wire cutter/ scissors, leaving 100mm to be tucked into the inner arm hole. See figure 8c.

Repeat for wiring the adjacent frame.

