

MYCANOE



United States Patent

GOD DESIGN



MYCANOE DUO OWNER'S MANUAL

WARNING!

Before you assemble or use MyCanoe, Please carefully read entire manual and follow all instructions. Failure to follow the instructions may result in serious injury or death. Keep this manual for future reference and provide it to anyone using MyCanoe.

Welcome to the world of Canoeing! ▶▶▶ Anytime Anywhere, MYCANOE !!

- MYCANOE is working passionately to make water sports such as canoeing more accessible to everyone.
- MYCANOE works with the Canoe Research Center to improve quality and develop new products.
- We may make improvements and changes to products at any time without announcement .
- To ensure safety during water sports, please follow all instructions in this manual.
- MYCANOE is always open to your suggestions and feedback.

Contents

1. What is MYCANOE DUO?
2. Assembly
3. Disassembly and Packaging
4. How to use Oar Lock (optional)
5. How to use Stabilizer (optional)
6. Safety guides
7. Maintenance
8. Troubleshooting
9. Warranty

Questions and suggestions

www.oricanoe.com
info@oricanoe.com

Explanation of symbols used in the user manual



Mandatory

Indicates that failure to follow instructions in the manual may lead to death or serious injury



Prohibition

Indicates that failure to follow instructions in the manual may lead to injury or damage to your MyCanoe



Warning

Guidelines to follow to prevent damage to the canoe.
Guidelines to follow when the canoe is broken or damaged
Important information for users
Information to make your experience more convenient

1. What is MYCANOE DUO?

MYCANOE DUO is a patented high performance origami folding canoe. MYCANOE DUO is a rugged and safe canoe made with one sheet of corrugated plastic that fits in a small sedan when it is folded. When it is unfolded and assembled, it transforms into a 14-ft canoe.

1.1 Materials

Main material polypropylene plastic (5mm poly-propylene)

Assembly method Buckles, rings

Other accessories Engineering plastic, stainless steel bolt, etc.

1.2 How big is MyCanoe?

Division	Assembled	Packed
Length	14.1 ft (430 cm)	2.95 ft (90 cm)
Width	38 in (98 cm)	10 in (26 cm)
Height	25 in (64 cm)	27 in (69 cm)
Weight	41.2 lb (18.7 kg)	41.2 lb (18.7 kg)

Images

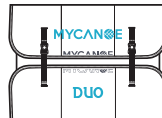

1.3 How much can MyCanoe carry?





• Maximum load
: 485 lb (220 kg)



• Recommended load
: 397 lb (180 kg)



Warnings

-  The maximum weight refers to the weight of the person on board and all other gears.
-  The maximum load can not be exceeded under any circumstances.
-  You must balance the weight distribution of the Mycanoe when sitting or loading gears.
-  If the maximum load has not been exceeded but weight distribution proves difficult, try to distribute weight evenly by moving the position of the seat or gears.
-  If weight distribution fails, try to limit weight of luggage or carry only a single person.

1.4 Parts name of MYCANOE DUO

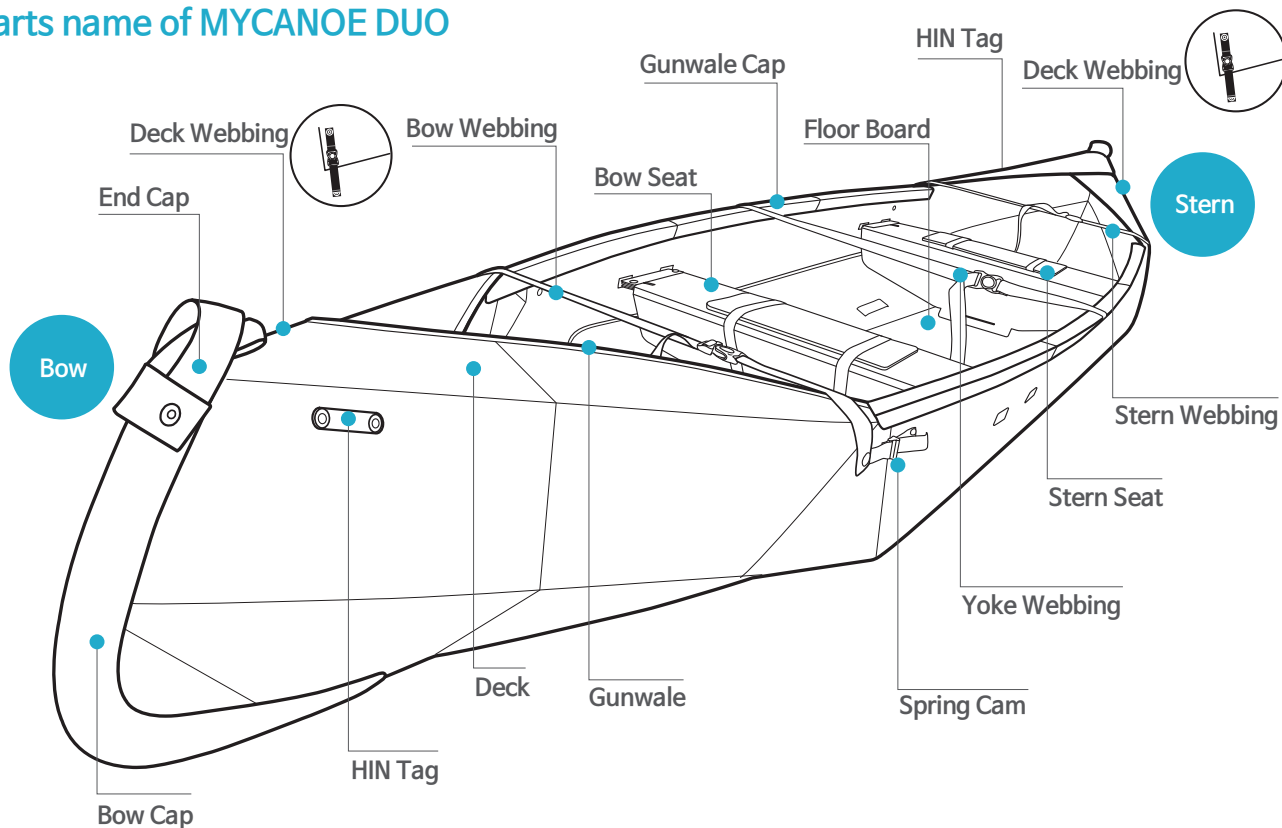

2. Assembly

Please watch assembly video at www.oricnoe.com. For the first time assembly, allow 5 minutes.

Once you understand the entire assembly steps, it should take 5~10 minutes.

If you need any assistance, please contact us either by phone at 800.566.6965 or email at service@oricnoe.com

PACKAGE BOX

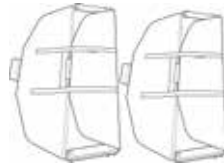
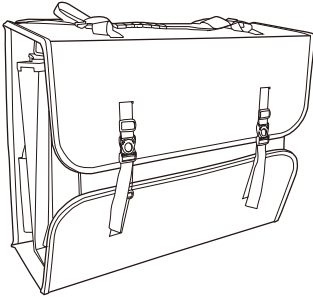

Seat

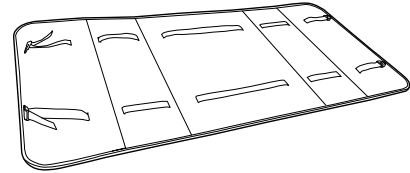

Floor Board

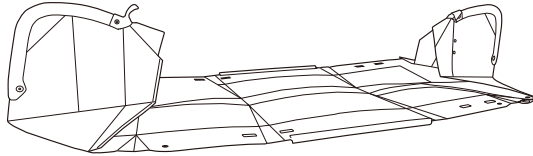

Hull



x2

Seat Pad



Manual & Repair Kit

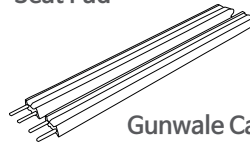

Gunwale Cap

2.1 Open and unfold the package

※Scan QR code on the floor board with your mobile phone and refer to the video clip on how to assemble it.



Duo
Assembly



Duo
Disassembly

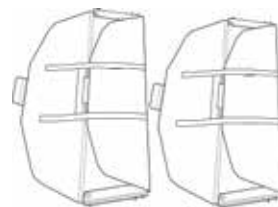

Assemble the seat using webbing.

1 Unbuckle the covers and remove the main body.

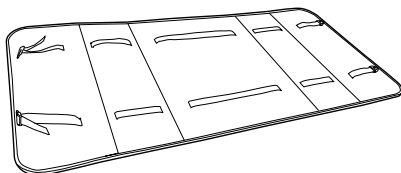

※The covers are used as canoe floors.

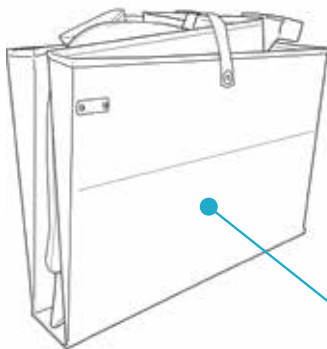

2 ⚡

If the folded main sheet is opened, it unfolds automatically. To ensure the main sheet is not caught on sharp rocks or edges, please unfold it on a flat surface.



Seat Pad

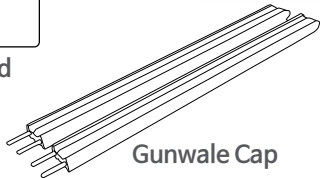

Gunwale Cap

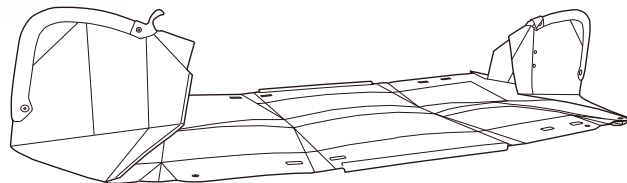

2.2 Assembly Step1

- ① Fasten the buckle of the central webbing.



- ② Press one side of the hull from inside to outside to spread.



- ③ Pull the webbing of the spring cam.
(It's easier to pull it while pressing the folding groove)

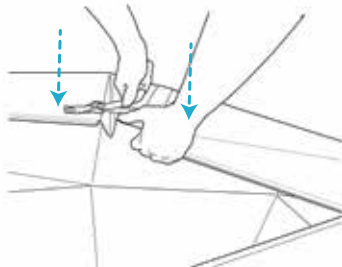

- ④ Connect the gunwale cap.

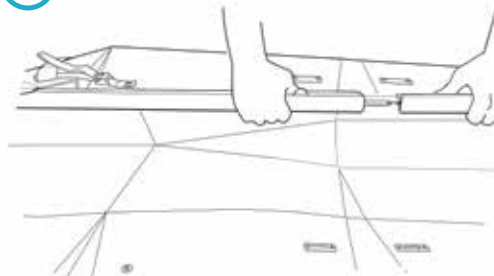

※ Please do all four places in the same way as above.

2.3 Assembly Step2

① Assemble 2 seats first

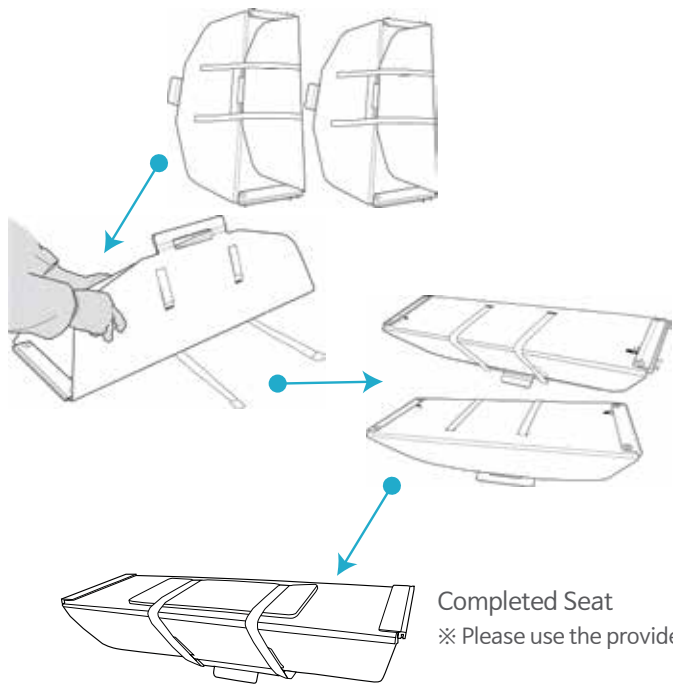

How to insert a seat

1. First, insert both pins of the seat into the hole of the holder as in ①.
2. Push the seat in the direction of ② (LOCK).

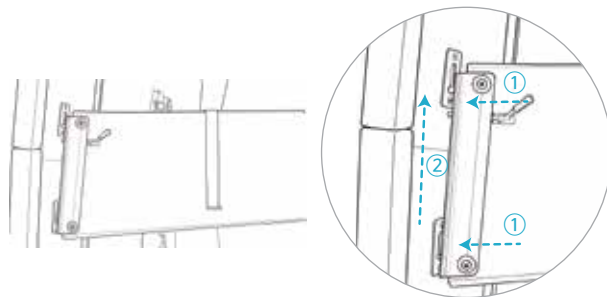

2.4 Assembly Step3

- 1 Place the floor boards and install the seats.

※ Please match MYCANOE logo puzzle to place the floor board in right position.

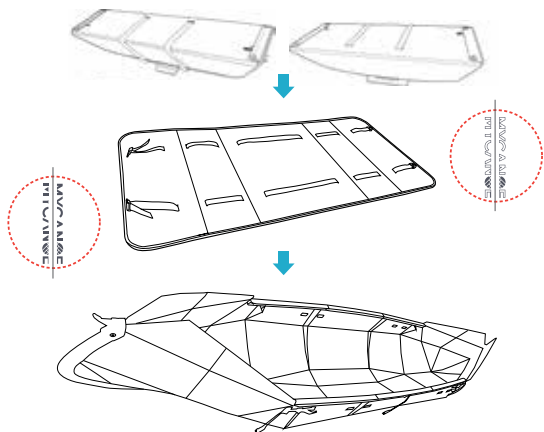

- 2 Fasten the buckle on the bow first, then tighten deck webbing. Please do the same for Stern.

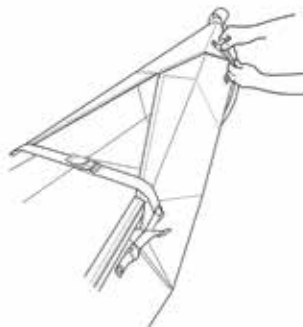

- 3 Completed MYCANOE DUO

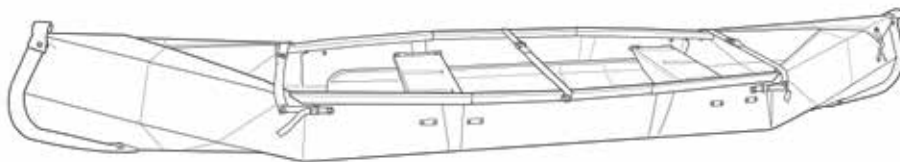

3. Disassembly and Packaging

3.1 Buckle release and the gunwale cap removal

① Release all buckles on the canoe

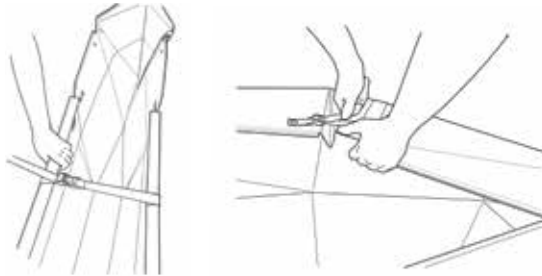

③ Remove the gunwale cap.

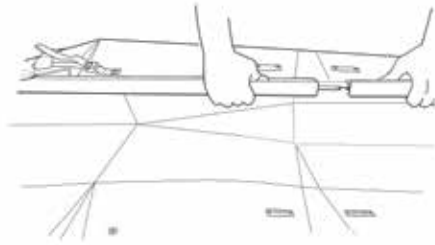

② Remove a seat.

How to remove a seat.

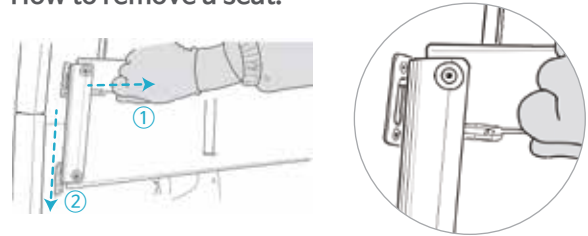

1. First, pull the stopper as in ①.
2. Push the seat in the direction of ② (UNLOCK).

3.2 Disassembly

①

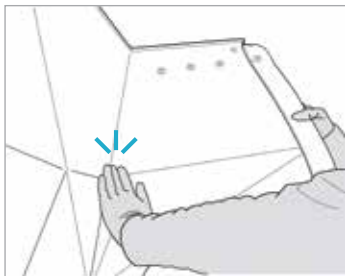
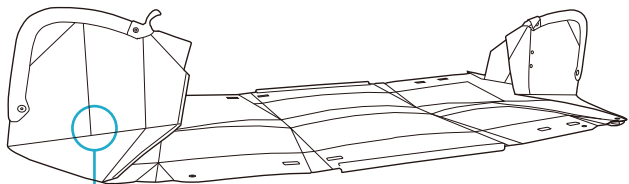

As shown in the figure, it is convenient to bend by pressing the vertex on the side of hull
Do the same way to the opposite side

②

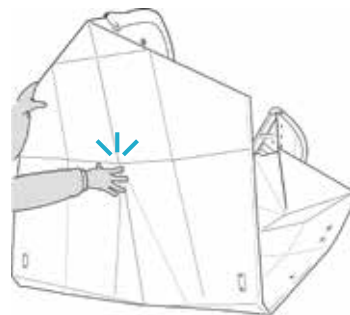

③



④

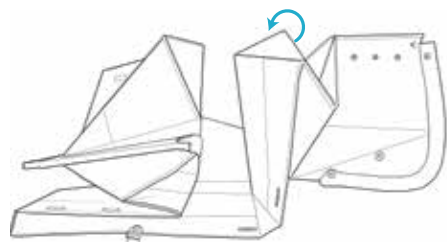

⑤

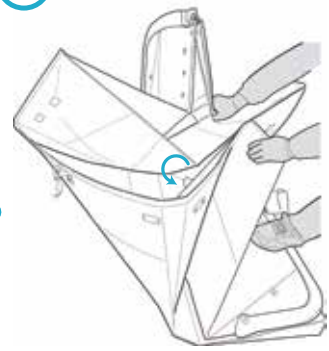

⑥

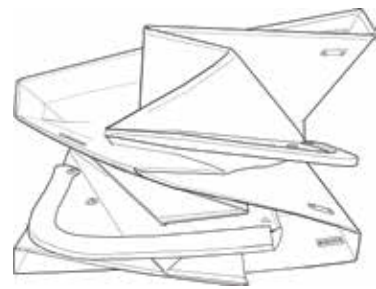

⑦

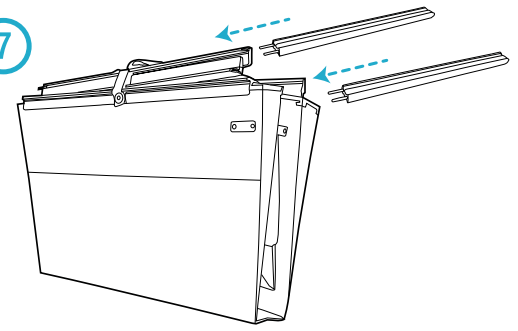

3.3 Making a package

Place one seat on the floor board, then place the body and the other seat in turn and buckle it.

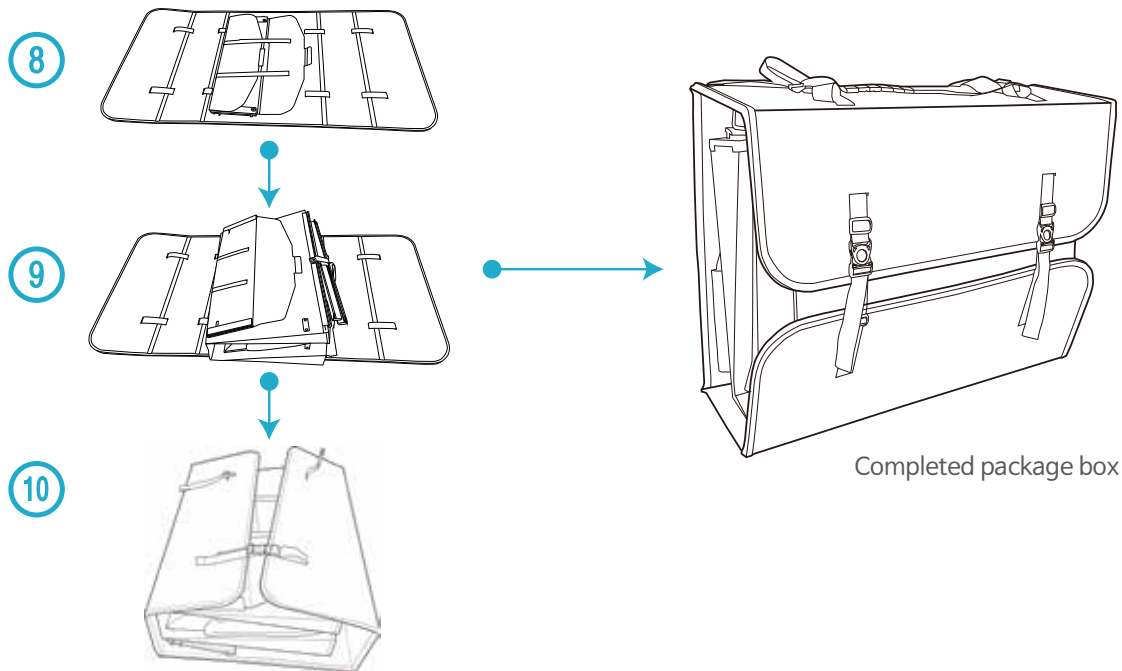

4. How to use Oar Lock (optional)

※ Oar lock is not included in the standard goods and must be purchased separately.

4.1 Oar Lock set Components



4.2 Parts name of Oar Lock

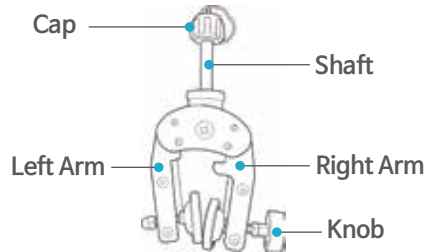

4.3 How to use

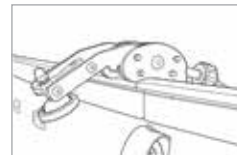
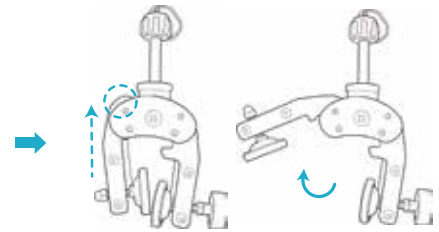

Insert the right arm into the gunwale cap, lower the left arm and turn the knob to fix it. (When lowering the left arm, push and lower.)

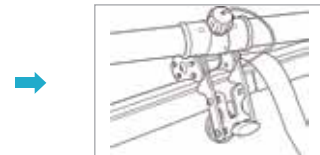

Open the cap and fit the oar into the shaft.

5. How to use Stabilizer (optional)

※ Stabilizer is not a standard product and must be purchased separately.

5.1 Stabilize Components



Tube+Foot Pump+Repair Kit+Bag

5.2 Parts name of Stabilizer

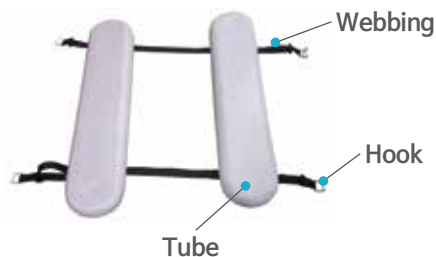

5.3 How to use

※ Before assembling the stabilizer, please refer to "5.4 How to injection to Stabilizer" to inject air first.



Place the stabilizer side by side on the floor.



Put the canoe in the middle of the stabilizer.



Put two hooks into the gunwale cap on one side of the canoe.



Tilt the canoe to the other side and fit the two rings on the other side into the gunwale cap.



Adjust the webbing by pulling it so that the tube is in close contact with the canoe.

5.4 How to injection to Stabilizer (optional)

Before Inflation

Open the valve cap.

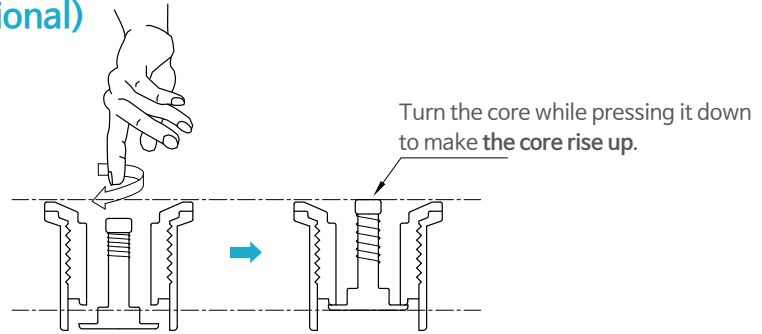
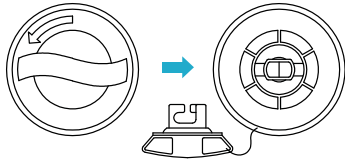

Inflation

With the core raised, Connect the pump inlet and inject air.

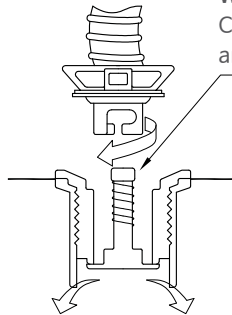

Inside of the stabilizer

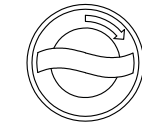

When inflation is complete, disconnect the pump inlet and close the valve

Deflation

Open the valve cap, turn the core while pressing it down, and hold. The air inlet will open.

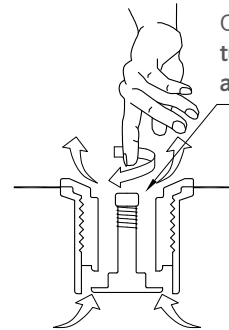





Close the valve cap when deflation is complete.





6. Safety guides

- As canoeing is an active sport, it may lead to dangerous situations if safety rules are not followed.
- Please acquaint yourself with detailed safety instructions and devices before beginning your canoeing experience.
- **When safety rules are not followed, all responsibility for accidents lies with the canoe operator.**

6.1 Before you go canoeing

-  Canoeing is a sport enjoyed on calm lakes or softly flowing inland waterways. Please do not go canoeing in water with waves such as the sea or in valleys.
-  You must not go canoeing if you are not feeling well or after drinking alcohol. Please go canoeing after adequate practice and stretching.
-  You must pay careful attention to the weather before you go canoeing.
-  If you detect a sudden change in the weather, please get out of the water immediately.

6.2 Safety devices and equipment used when canoeing

-  Always use a U.S. Coast Guard - approved life jacket or personal flotation device (PFD). Read the PFD manufacturer's instructions and familiarize yourself with how the PFD should be worn. You must not take off your life jacket under any circumstances.
-  Adequate measures to stay warm must be undertaken.
-  Practice using all safety equipment until you are familiar with the equipment.
-  The canoe must be assembled completely. Incomplete assemble may result in injury or death.
-  You are advised to prepare a whistle or other communication device to call for help in case of emergency.







Necessary equipment

- Safety equipment : lifejacket
- Paddle : Single edge paddle for use with canoes
- Communication device : cell phone, walkie talkie, emergency contact device (whistle, lantern, etc.).

Extra equipment

- Emergency medical supplies, emergency food, body warming clothes.
- Map and compass.

6.3 Information to be aware of when canoeing

-  Going canoeing alone is dangerous. If you do need to go canoeing alone, you might need to seek emergency assistance from people nearby in case of emergency.
-  Please ensure you don't load the canoe with more than the recommended weight in passengers or gear. In no circumstances should you exceed the maximum weight allowed.
-  After getting in the canoe, do not stand up or shift the weight balance until you get out of the canoe.
-  Ensure children go canoeing with an adult guardian.
-  Canoeing should only be enjoyed on calm lakes or slow-moving inland waterways. They must not be used in waters where there are fast currents, tidal currents, or high waves.
-  Go canoeing in water deeper than 12 in (30cm). Using the canoe in water shallower than this may result in scratching the bottom of the canoe and other damages.

Depending on the weather, you are advised to wear clothes that will keep you warm.

7. Maintenance ⚠️⚠️

The lifespan of your MyCanoe may be shortened if proper maintenance on the product is not carried out. Please refer to the guidelines below for maintenance and care.

- ⚠️ Use a special dock or wharf when getting in/out of the canoe.
 - If a dock is unavailable, use a place with soft sand or soil. Using a place such as a rocky coastline or a place with many stones may result in scratching the bottom of the canoe and other damage.
 - Do not pull or push the canoe when the bottom of the hull is touching a surface may result in damage to the hull.
- ⚠️ Ensure you do not bump into or crash into sharp rocks.
 - Ensure the hull does not come into contact with sharp edges when loading or placing luggage on the canoe. This may damage the hull. Place heavy luggage on the bottom of the floor board.
 - If damage occurs after a collision with a sharp object/edge, use double-sided waterproof tape to secure the canoe as an emergency measure.
※When transporting the canoe a short distance, use the shoulder strap.

⚠️ Emergency repair

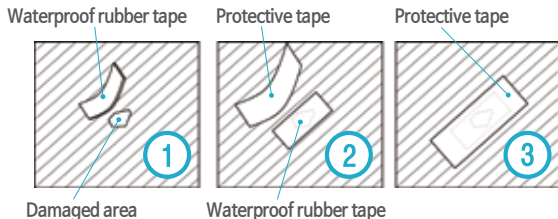

The corrugated plastic sheet requires special maintenance measures.

- ⚠️ Avoid using, packaging, or assembling the canoe in freezing temperatures. The main material plastic may crack.
 - ⚠️ As MyCanoe is made of a corrugated plastic sheet, it may melt if exposed to direct heat.
 - ⚠️ Wipe clean if canoeing took place in dirty water or if the hull becomes dirty.
 - ⚠️ Dry the canoe after canoeing by turning the hull over and removing any water trapped inside. (Water may be trapped between the plastic molding. Remove water before storing.)
 - ⚠️ After drying, fold into packaged form and store in a place not exposed to direct sunlight. Please note that discoloration or deformation may occur if the product is exposed to sunlight for long periods of time.
 - ⚠️ Please note that the corrugated plastic sheet is easily scratched and may inadvertently be created
 - ⚠️ Please assemble the canoe in a place without grass or pebbles. When assembling the canoe, if you place your feet in the canoe during assembly, any stones on the bottom of your feet may damage the canoe.
- ⚠️ Any modification or changes made by customers will void warranty. Please email service@oricanoe.com or call us at 800-566-6965 for service request.

8. Troubleshooting

- If Mycanoe leaks or damaged, paddle to the nearest shore and remove the water before repairing the canoe.
- If minor damage occurs in specific sections of the hull, use waterproof tape for emergency repair. You can also use a glue gun before applying a tape for better sealing.
- If minor water leakage occurs near the bolt in the hull, tighten it using an appropriate tool.

MYCANOE (USA)

P.O. Box 22463 KNOXVILLE, TN 37933
800-566-6965
E-mail: service@oricanoe.com
Homepage : www.oricanoe.com

MYCANOE (Headquarter)

mycanoe@mycanoe.co.kr / www.mycanoe.co.kr



9. Warranty

- The manufacturer is directly responsible for the product warranty and after-sales customer service.
- If a manufacturing defect or repair needs to be made within one year from the date of manufacture, an exchange or repairs will be provided without charge.
- If the product is damaged due to customer negligence or failure to follow safety guidelines, repairs will be made at cost to the customer.
- Please fill out the form below for convenient customer service.
- In particular, Hull Identification Number (HIN) is the unique number of your canoe and is attached to the outside and inside of the hull.

MYCANOE DUO		Purchase date							
Purchase location/agent									
HIN	COO	<input type="checkbox"/>	<input type="checkbox"/>	<input type="checkbox"/>	<input type="checkbox"/>	<input type="checkbox"/>	<input type="checkbox"/>	<input type="checkbox"/>	<input type="checkbox"/>

MY Special Outdoor Event

Camping • Traveling • Fishing Gear



MYCANOE(USA)

P.O. Box 22463 KNOXVILLE, TN 37933

800-566-6965

E-mail : info@oricanoe.com

Homepage : www.oricanoe.com

MYCANOE(Headquarter)

mycanoe@mycanoe.co.kr / www.mycanoe.co.kr

© 2021 Mycanoe ALL RIGHT RESERVED

MYCANOE