

**vita**

**ASSEMBLY GUIDE
GUIDE DE MONTAGE
GUÍA DE MONTAJE**

URBANA

17X17 RAISED PLANTER

JARDIN SURÉLEVÉ 17X17

JARDINERA LEVANTADA 17X17

VT17510 / VT17610

ESPRESSO
ESPRESSO
ESPRESSO

SLATE
ARDOISE
PIZARRA

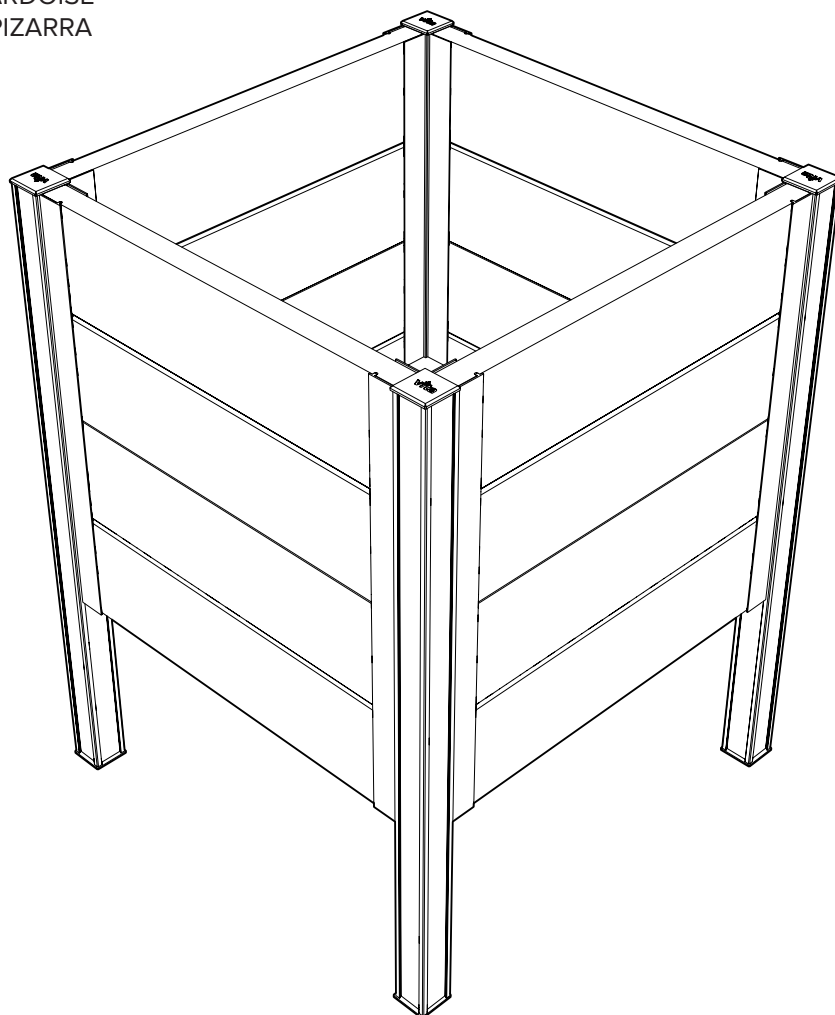

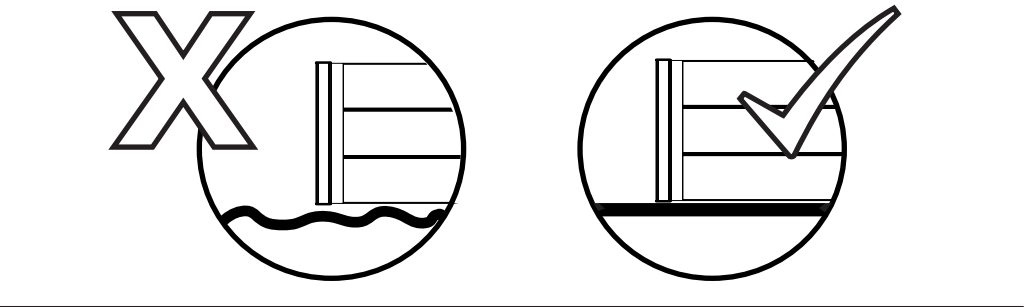
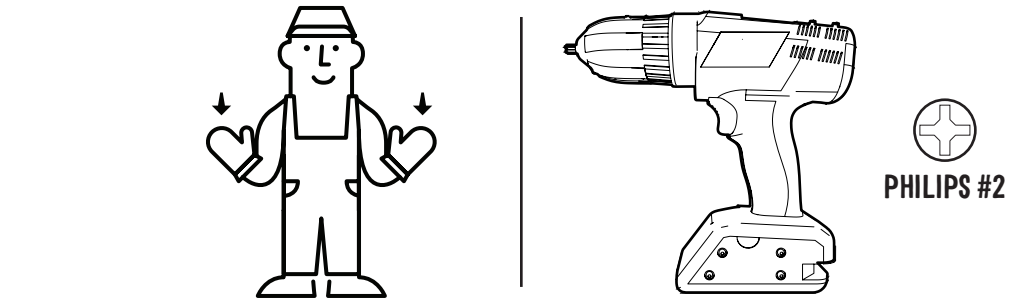
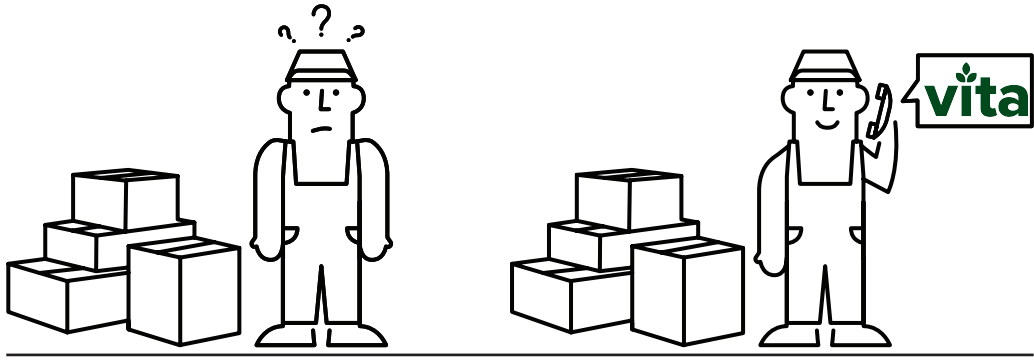

 **1-800-282-9346**

HELLO@WEAREVITA.COM

WWW.WEAREVITA.COM



8:00 AM - 5:00 PM EST



PARTS LIST

LISTE DES PIÈCES

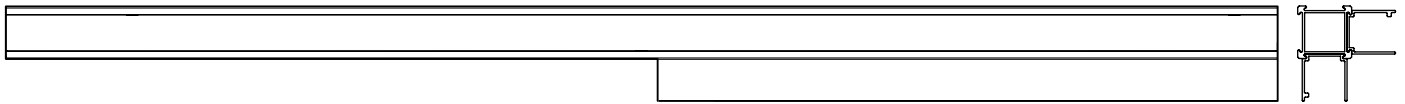
LISTA DE PARTES



16017

POST - PUBLIER - EXPONER
21 3/4IN (55.2CM) - **X4**

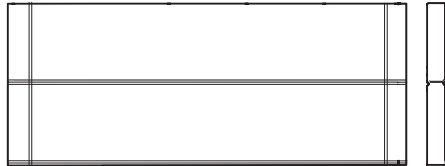

16018 - SLATE - ARDOISE - PIZARRA

15018 - ESPRESSO - EXPRESSO - ESPRESSO

BOARD - PLANCHE - TABLA
14 1/4IN (36.3CM) - **X8**

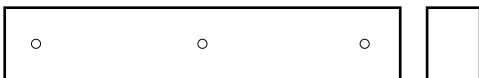

16034 - SLATE - ARDOISE - PIZARRA

15034 - ESPRESSO - EXPRESSO - ESPRESSO

FLOOR BRACE - BRACE DE PLANCHER - BRACE DE PISO
14 1/4IN (36.3CM) - **X2**

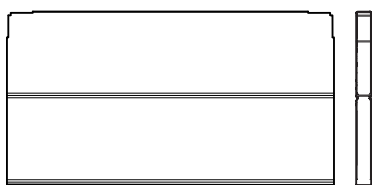

16035 - SLATE - ARDOISE - PIZARRA

15035 - ESPRESSO - EXPRESSO - ESPRESSO

FLOOR BOARD - PLANCHE D'ÉTAGE - TABLERO DE PISO
14 3/4IN (37.4CM) - **X2**

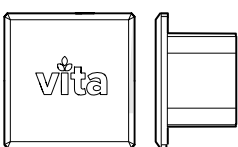

16003

POST CAP - TETE DE POTEAU - TAPON
1 1/4IN X 1 1/4IN (3.2CM X 3.2CM) **X8**

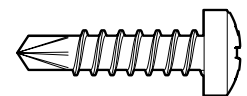
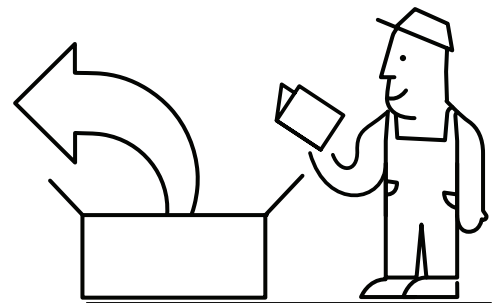

20066
SCREW A
VISSER D
TORNILLO D
5/8IN (1.6CM)
X4

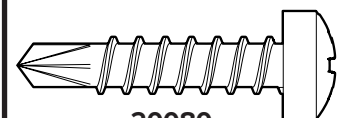

20080
SCREW B
VISSER E
TORNILLO E
1 1/4IN (3.2CM)
X6



PRODUCT DIMENSIONS

DIMENSIONS DU PRODUIT

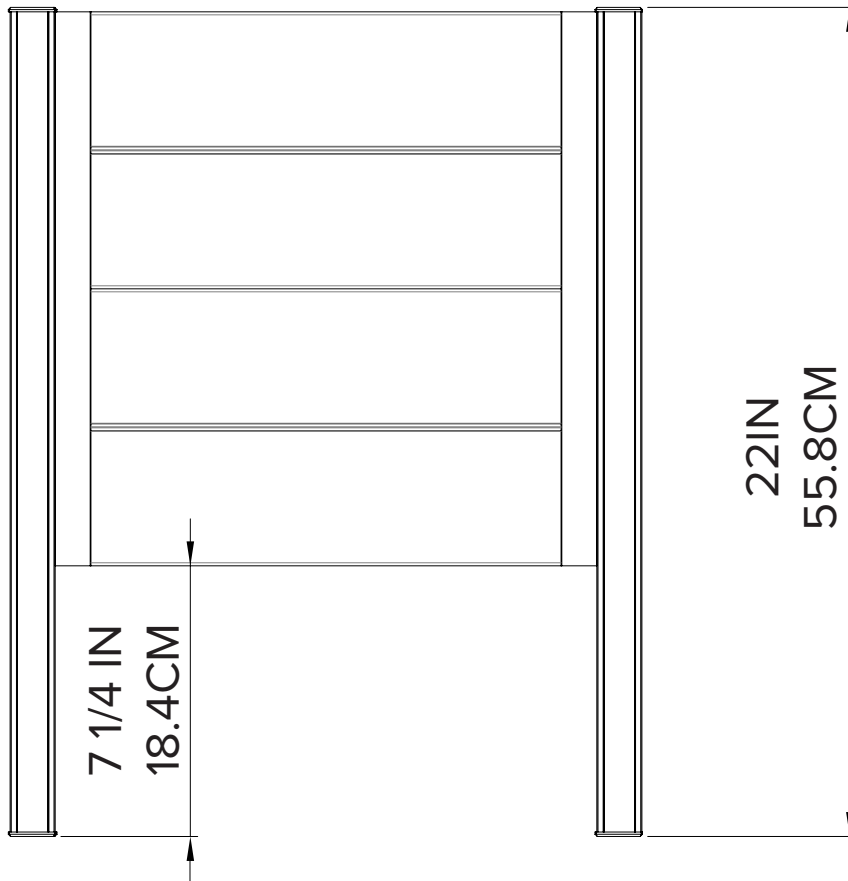
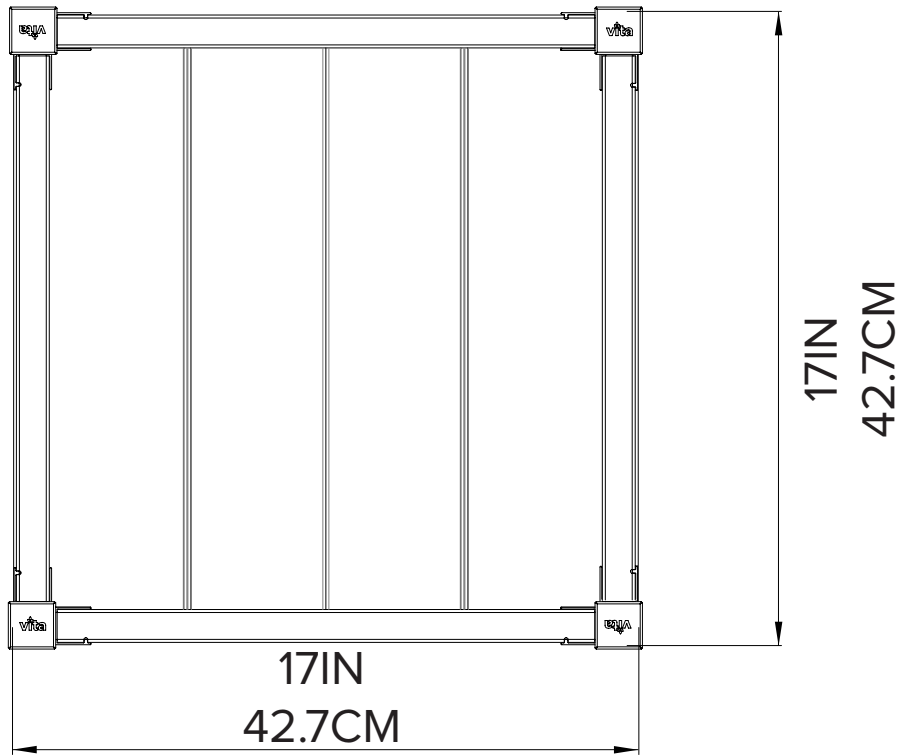
DIMENSIONES DEL PRODUCTO



1

16017 - x2 
16018/15018 - x2 

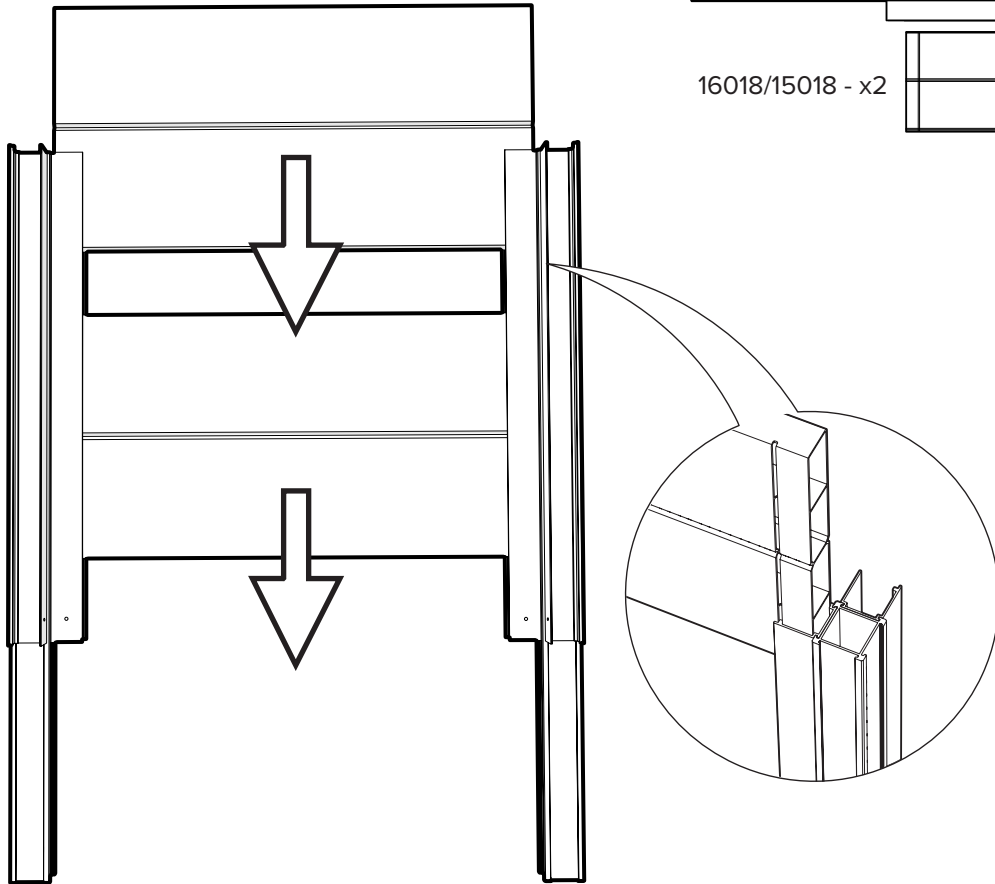

2

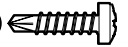
20066 - x2 

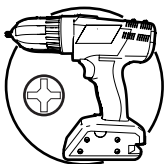
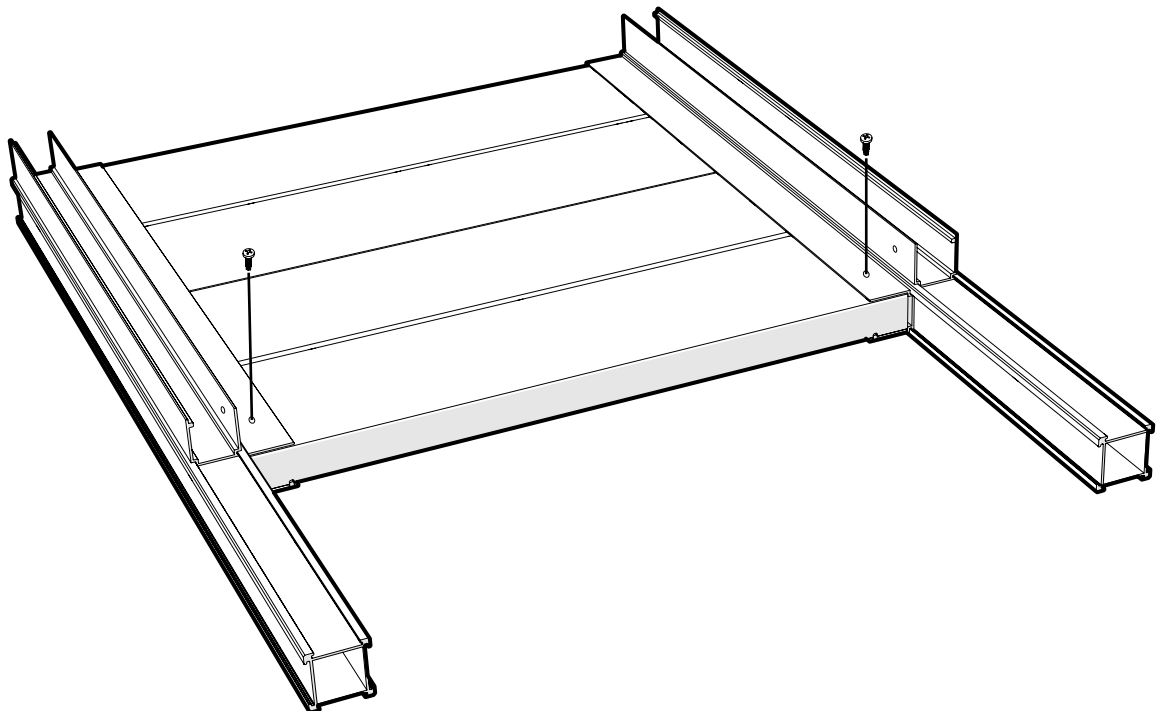

PHILIPS #2



3

16017 - x1

16018/15018 - x2

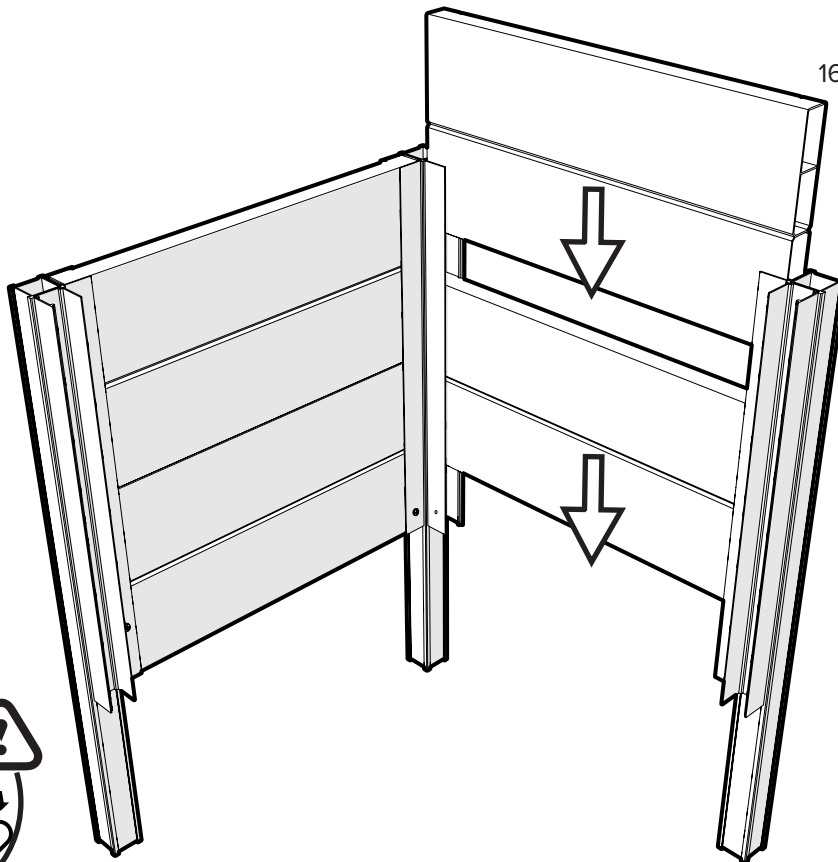

4

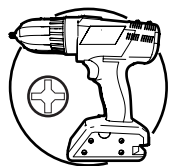

PHILIPS #2

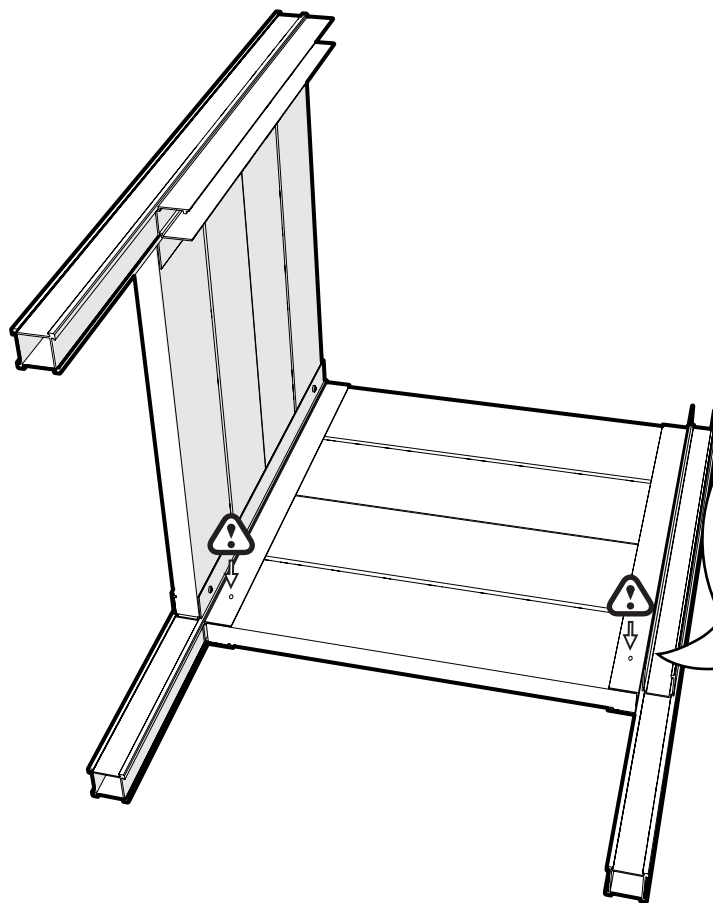

5

16017 - x1

16018/15018 - x2

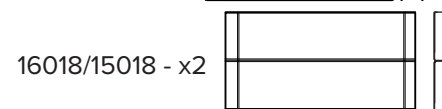
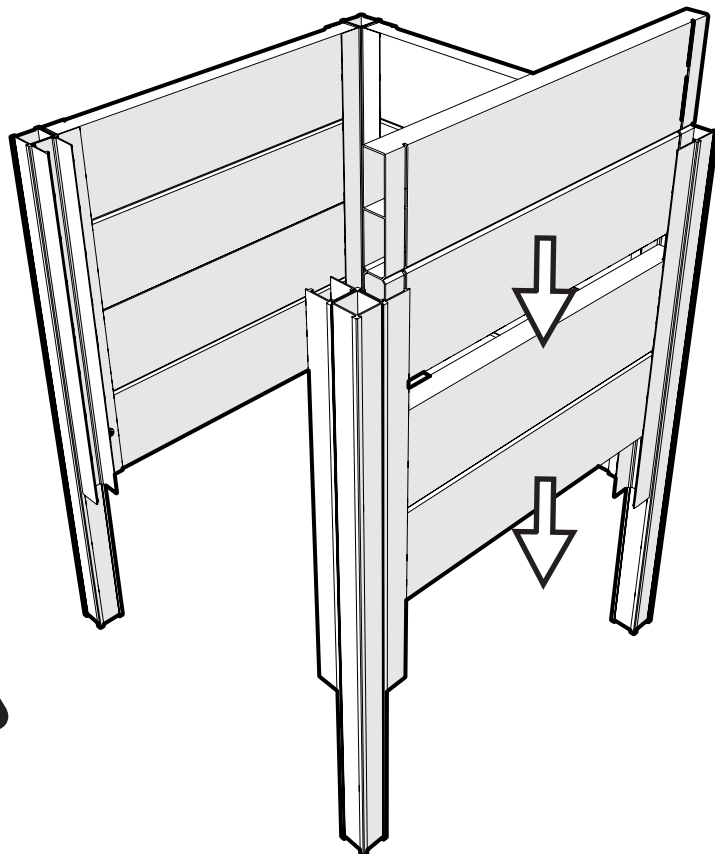

6

20066 - x2 (A)

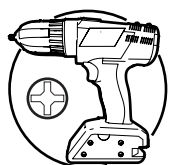
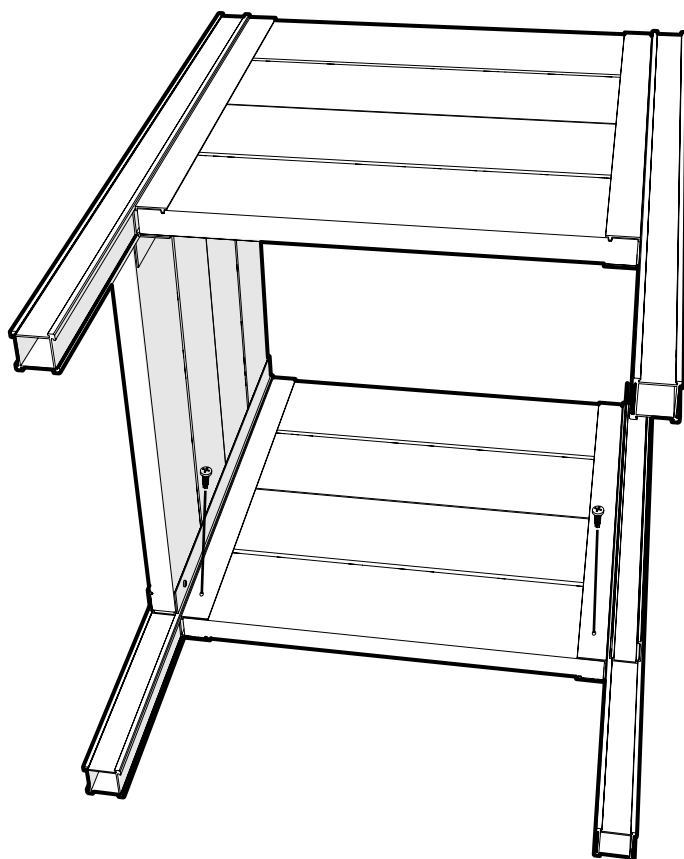

PHILIPS #2



7

16018/15018 - x2

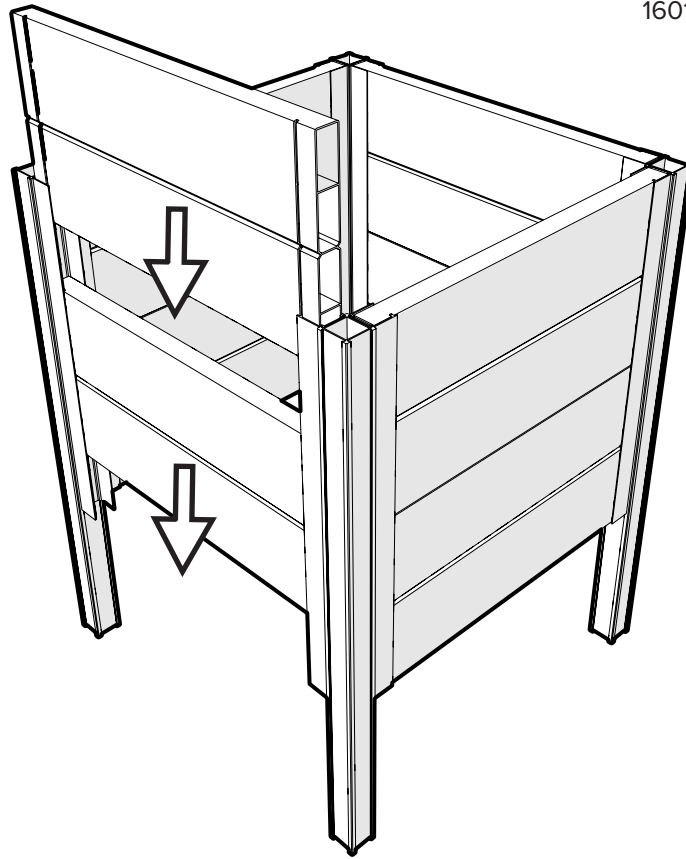

8

20080 - x3 (B)



16034/15034 - x1

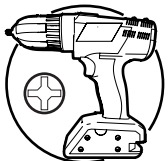
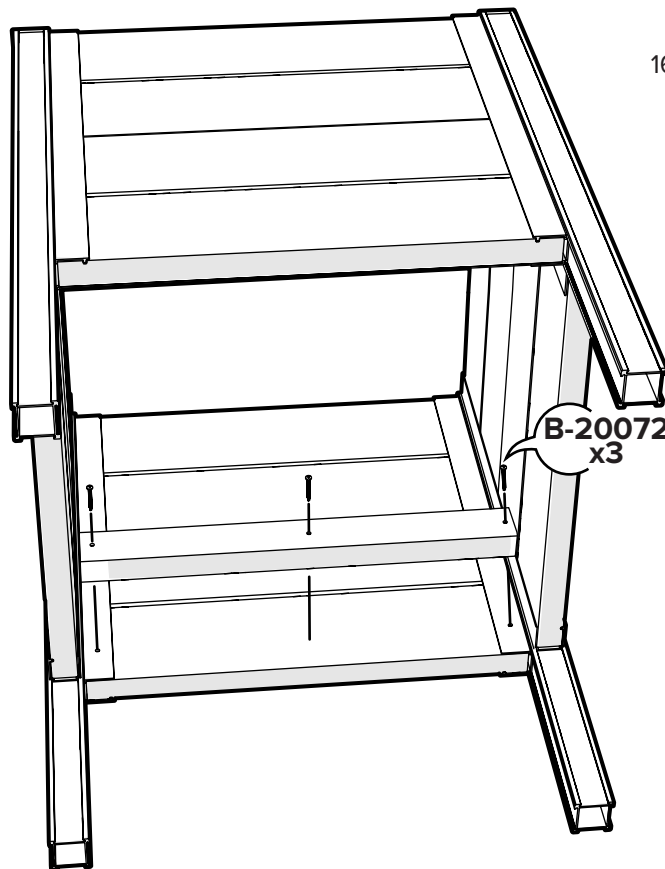
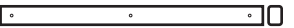

PHILIPS #2

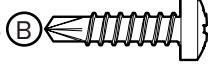

9

20080 - x3 

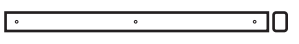
16034/15034 - x1 

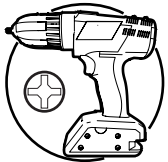
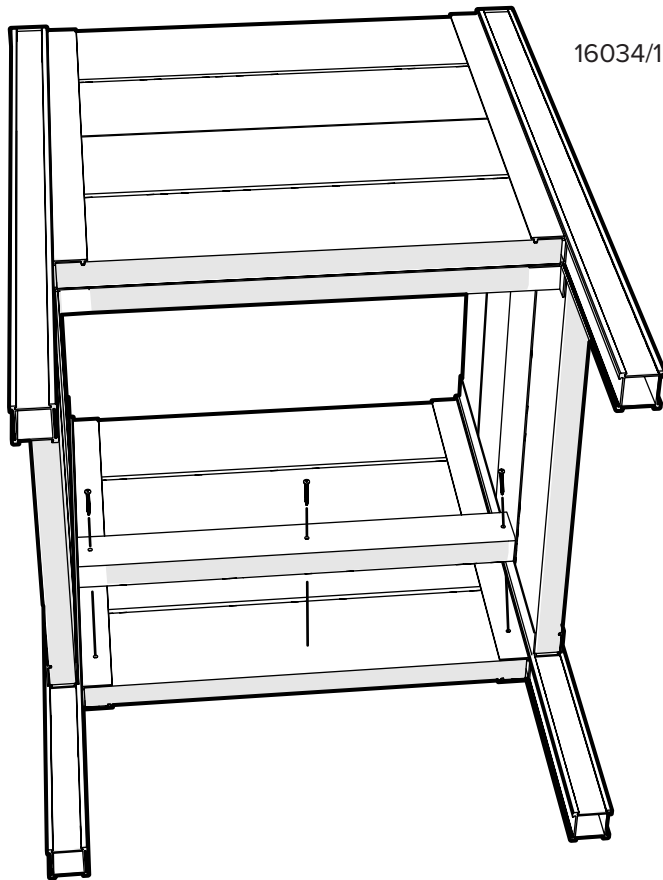

PHILIPS #2

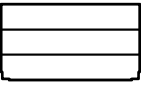

10

15035/16035 - x2 

16003 - x8 