

EDMUND WALL SCONCE

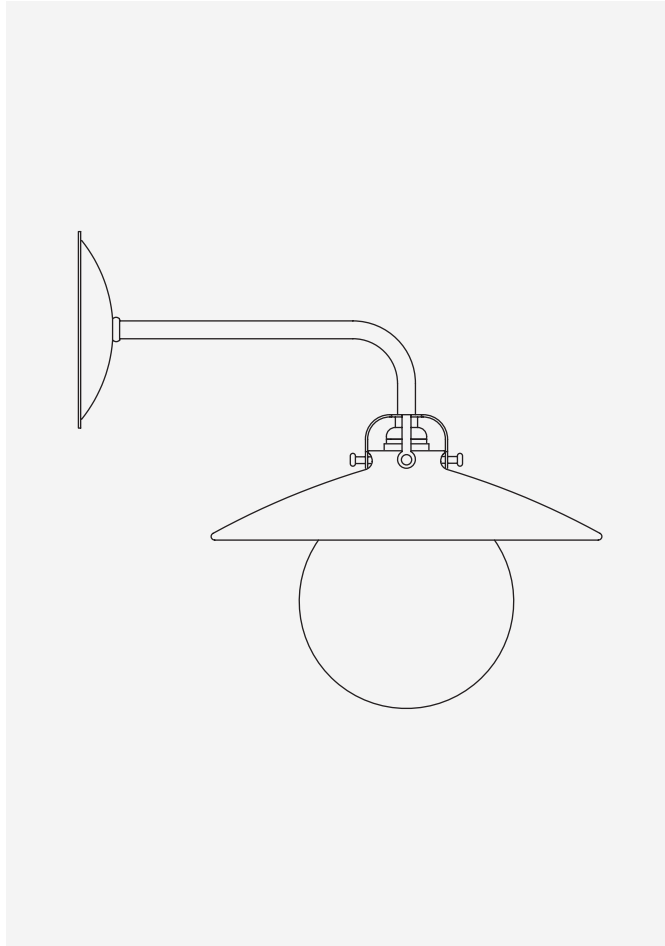



DESCRIPTION

The hand-turned shade and oversized clear globe create a playful silhouette while delicate cut brass fittings and hardware are sure to compliment any space. Choose between a clear, brighter finish, a warmer natural maple finish, or black walnut.

SPECIFICATIONS

Wooden Shade + Backplate

- 

Black
Walnut
- 

Clear
Maple
- 

Natural
Maple

Metal

- 

Satin Brass

Materials	Wooden shade and detail, brass socket, arm and fittings.
Lamping	1 x E26. 250V/250W
Bulb	To ensure lifelong performance we recommend the use of LED bulbs under 40 watts.
Certification	Can be UL certified. Please inquire.
Product Weight (lbs)	2.90

CARE

Please care for the brass pieces with a soft cloth, and avoid using any abrasive cleaners or products.

Natural patina process is quickened by touch and exposure. Gloves are recommended for installation.

We recommend using a microfiber dust cloth to care for wood fixtures. Kindly avoid additional cleaners and products.

NOTES

1. The wooden shade is hand-turned. Some variance in the wood grain is to be expected.
2. Dimming compatible.
3. Dry location rated.
4. Made to order. Please allow 4 - 6 weeks for delivery.
5. Finish samples are available upon request.

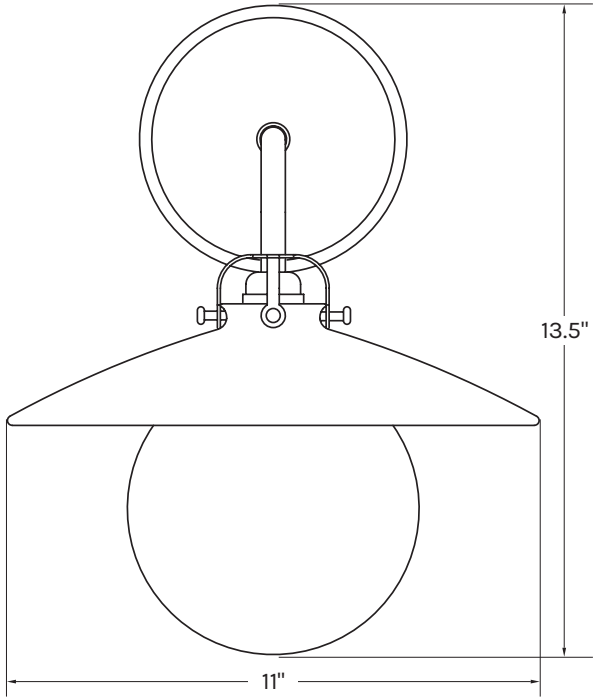
DIMENSIONS	ISOMETRIC VIEW
<p>Shade: 11" DIA</p> <p>Depth: 14.5" D</p> <p>Backplate: 5.5" DIA</p> <p>Height: 13.5" H (Overall)</p> <p>Globe: 6" DIA 3" DIA (Opening at the top)</p>	

DIMENSIONS	SIDE VIEW
<p>Shade: 11" DIA</p> <p>Depth: 14.5" D</p> <p>Backplate: 5.5" DIA</p> <p>Height: 13.5" H (Overall)</p> <p>Globe: 6" DIA 3" DIA (Opening at the top)</p>	