



# *CD-S2100*

Compact Disc Player

New circuit design for elimination of audio loss, plus high-precision drive mechanism for reproduction accuracy. This high-grade CD player delivers the new sound of Yamaha, and is equipped with high-performance USB audio and DAC, and other advanced functions.

The S2100 Series was born from the goal to deliver new Hi-Fi components with superior musicality —components which can be created only by the world's premier musical instrument manufacturer, Yamaha. The CD-S2100 CD player incorporates many high sound quality technologies such as a new circuit configuration, high-performance DAC, and other features which have been adopted for use in our flagship models, in order to extract and transmit all the audio information recorded on discs without any loss.

It also includes USB audio input and advanced DAC specifications that let you enjoy the newest music formats including high-resolution sound sources with the best sound quality.

Here is the highest level of sound quality and functionality, giving you the full experience and greatest musical enjoyment you can get from all your music contents including CDs.

In the quality of the sound, in the level of the functionality, we sought to deliver the absolute best.

- Left-right symmetrical construction and Independent configuration of digital/analogue circuits with optimisation of power supply
- Reinforcing anchors and rigid CD mechanism for high precision signal reading
- High-performance, high-resolution 32-bit DAC from ESS for an airy, open and transparent sound with all the audio data intact
- Built-in USB DAC functions are compatible with high-resolution audio sources, allowing use of the superior D/A conversion capability of the CD-S2100

**Left-right symmetrical construction, independent digital/analogue circuit configuration, with top priority on sound quality**

The CD-S2100 has completely symmetrical construction: the rotating loader mechanism is in the centre, the digital power supply and circuit board are on the left side, and the analogue power supply and circuit board are on the right. Completely isolating the digital unit and the analogue unit eliminates detrimental impacts of interference between the circuits, while achieving ideal weight balance. The centre frame that extends from the front to the back of the body and the front panel made of 5mm (1/4") thick aluminium increases rigidity of the entire chassis and ensures stable disk play.

**Digital/analogue circuitry with integrated power supplies and screw type connections eliminate signal transmission loss**

The internal design of the CD-S2100 does not separate the power supply circuit boards, which include the power transformer; the block capacitors are mounted directly on the respective digital/analogue circuit boards. Thus, an original board configuration which integrates the power supply circuits was adopted.

Eliminating cabling from the power supply circuits to each circuit board and mounting directly have the benefit of reducing connection loss, as well as achieving low impedance. Moreover, cabling from the power



transformer utilises the same screw-type connections we've given the companion A-S2100 Integrated Amplifier. Connecting directly without soldering achieves thorough contact point loss and low impedance. Signal is transmitted to the amp without loss of any information that has been read, delivering sound reproduction filled with a sense of energy and crisp openness—the over-arching aim of the S2100 Series.



**Single-stage configuration I/V conversion circuit enables direct analogue output**

To thoroughly eliminate audio signal loss, the CD-S2100 adopts an innovative circuit configuration for the analogue circuit. The signal from the D/A converter is conventionally output as an analogue signal through an I/V conversion circuit configured in multiple stages. However, in the CD-S2100, the signal is output by a single-stage configuration based on a discrete design of the I/V conversion circuit. This single-stage configuration with high slew-rate sharply lowers audio signal loss compared to a multi-stage configuration circuit, and lowers NFB (Negative Feedback), eliminating any sonic suppression, resulting in a natural, spacious sound. The circuits beyond this D/A converter perform balanced transmission with a circuit

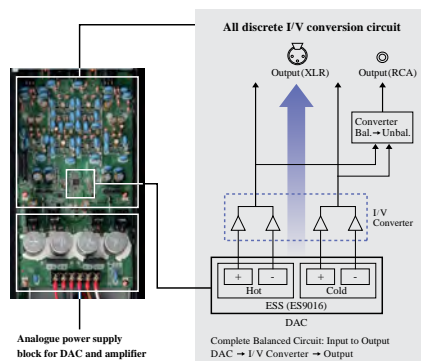

configuration marked by symmetrical plus and minus sides. Using a balanced connection with the A-S2100 Floating and Balanced Power Amplifier lets you enjoy profoundly pure sound reproduction without any impact of transmission loss.

**Independent power supplies with complete separation of digital and analogue**

The CD-S2100 has adopted a twin power supply transformer method, complete with separate, dedicated power supply transformers for the digital and analogue circuits.

Isolating the digital and analogue circuits starting at the transformer step eliminates sound quality deterioration caused by interference and noise between the digital and analogue units—a problem that occurs when they share the same power supply. This results in exceptionally clear, low-noise reproduction of analogue audio. Moreover, the power supply transformer for the analogue circuit is a toroidal transformer that provides stable power supply with low magnetic flux leakage, and the winding, stabilised power supply circuit is completely isolated on the left and right sides. This achieves superior separation—a particularly important point in Hi-Fi audio.





### High precision CD drive for greater vibration resistance and high-precision signal reading

The CD-S2100 is equipped with the same drive mechanism as the Yamaha flagship model CD-S3000, in order to perform high-precision reading of the vast quantity of audio data recorded on a disk. And the loader mechanism is connected firmly to the chassis by installing heavy, specially specially bent 1.6mm (1/16") thick iron reinforcing anchors in front of and behind the loader mechanism, eliminating the transmission of vibration caused by disk rotation to the circuit board. In the process of assembling the CD-S2100, after the drive mechanism has been attached to the chassis, horizontal fine adjustment of each anchor is performed carefully. While this is troublesome, it shows Yamaha's commitment to providing the ultimate in precise signal reading. By eliminating even the slightest tilting of the mechanism, this achieves stabilised rotation and ultra-precise reading. Reducing the load of the servo that drives the pickup and lowering the impact of change of servo amperage on the signal, achieves clean signal read out with little impact of noise—drawing out every little nuance the artist has recorded.

### High rigidity aluminium CD tray

The CD tray is made of high rigidity aluminium, reducing secondary vibrations due to resonance of the disc and the high-speed motor rotating the disc, resulting in improved audio signal-reading precision and quieter operation. In addition to the smart design and luxurious texture, we've fine-tuned the opening/closing action by



adding a specially designed meshed wire drive, achieving smoother and gentler operation. We obsessively strove to give the unit a luxurious operating feel that perfectly matches the superior sound quality.

### Exceptionally high performance 32-bit D/A converter

The D/A converter for the CD-S2100 is the ES9016 from ESS Technology, Inc. We selected this after careful examination of all points—not only its high-precision processing of 32-bit audio, but also the ability to handle large amounts of audio data, strength in the low register, and high-quality definition in the high register. Since the built-in D/A converter generates its own master clock, an original Jitter Elimination function is also included, permitting D/A conversion with extremely low impact of clock jitter. Moreover, an 8-channel D/A converter is housed inside the chip, and applies double differential operation using 4-channel D/A converters on the right and left sides respectively. It delivers exceptional high performance and high-quality signal output with superior signal-to-noise ratio, since it employs an analogue signal processing circuit with balanced configuration.

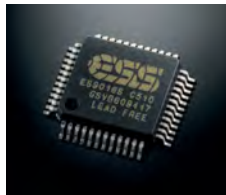

### Built-in USB DAC functions, and ASIO 2.3 Yamaha Steinberg USB Driver

For optimum enjoyment of today's high-resolution audio sources, we designed the CD-S2100 with superior D/A conversion and balanced signal output, and equipped it with a built-in USB DAC function which allows direct input of digital audio (from a computer, etc.). The USB DAC employs an original IC, developed specifically for Yamaha. It has an internal master clock, and can perform low-jitter transmission. The CD-S2100 supports the ASIO 2.3 protocol to take full advantage of the sound



quality of the USB DAC function. The ASIO 2.3 protocol is a standard protocol for professional use digital audio or DTM, with a significant sound quality benefit: the ability to achieve lower delay and higher throughput than with a standard OS sound driver. The driver software is the ASIO 2.3 Yamaha Steinberg USB Driver\*, and allows high quality playback of digital audio data stored to computer. The unit is compatible with digital audio of up to 192kHz/24-bit resolution and supports DSD native playback.

\*The software is available as a free download from the Yamaha web site.

### Beautiful, sleek design and half-mirror display

Inside and out, the CD-S2100 fully demonstrates Yamaha's commitment to fine craftsmanship, and its long history as a premier maker of musical instruments. In the connections between the front panel and the side wood, masterful use of advanced processing technology beautifully integrates different materials, metal and wood. On the CD tray, the gap between the front panel and the tray is uniformly precise. The display unit is of half-mirror design, with track information beautifully displayed during CD playback, and at the same time, when the power supply is off, it harmonises beautifully with the aluminium hair-line finish of the front panel.

### Remote control with simple design and superior texture

The supplied remote control is designed in the same way as the aluminium panel of the CD player itself, with a simple, easy-to-understand button layout and gorgeous metallic texture. In addition to the basic CD track selection and play controls, it can also be used to adjust the volume and switch input sources on the companion A-S2100.





### CD-S2100 Main Specifications

**[AUDIO SECTION]**

Media Compatibility		SA-CD, CD, CD-R/RW (MP3, WMA) , USB (Type B)
Frequency Response	CD	2 Hz–20 kHz
	SA-CD	2 Hz–50 kHz -3dB
Harmonic Distortion	CD (1 kHz)	0.002%
	SA-CD (1 kHz)	0.002%
Signal-to-Noise Ratio (IHF-A Network)	CD/SA-CD	116 dB
Dynamic Range	CD	100 dB
	SA-CD	110 dB
Output Level	CD/SA-CD (1 kHz, 0 dB)	2 ± 0.3 V

**[GENERAL SECTION]**

Dimensions	(W x H x D)	435 x 137 x 438 mm 17-1/8" x 5-3/8" x 17-1/4"
Weight		16 kg;
		35.2 lbs.