

### Model(s):

SF-WM58-BK  
SF-WM70-BK  
SF-WM94-BK



### NOTICE



#### DO NOT DISCARD THIS MANUAL

- Important operating and maintenance instructions included.
- Read, understand and follow these instructions for safe installation and operation.
- Leave this manual with party responsible for use and operation.

**DO NOT  
DISCARD**

### Congratulations!

Congratulations on selecting a SimpliFire Electric Fireplace, an elegant and clean alternative to wood & gas burning fireplaces. The SimpliFire electric fireplace you have selected is designed to provide the utmost in safety, reliability, and efficiency.

**READ CAREFULLY BEFORE ATTEMPTING TO ASSEMBLE, INSTALL, OPERATE, OR MAINTAIN THIS PRODUCT.**

**PROTECT YOURSELF AND OTHERS BY OBSERVING ALL SAFETY INFORMATION. FAILURE TO COMPLY WITH INSTRUCTIONS COULD RESULT IN PERSONAL INJURY AND/OR PROPERTY DAMAGE.**

**⚠ WARNING: To reduce risk of fire, electrical shock, or personal injury, read all instructions before using appliance.**

Please contact your SimpliFire dealer or customer/technical support (877-320-0730) with any questions or concerns.  
For the location of your nearest SimpliFire dealer, please visit [www.hearthnhome.com](http://www.hearthnhome.com).

*Printed in China - Copyright 2021*

# 1 IMPORTANT INSTRUCTIONS

## IMPORTANT SAFETY INSTRUCTIONS

### **WARNING! Risk of Fire! Risk of Burns! Risk of Electrical Shock!**

#### **DO NOT:**

- Install or operate damaged heater
- Modify heater
- Operate the heater without fully assembling all components

Hearth & Home Technologies Inc. disclaims any responsibility for, and the warranty and agency listing will be voided by the above actions.

**WARNING! DO NOT operate fireplace before reading and understanding operating instructions.** Failure to operate appliance according to operating instructions could cause fire or injury.

**WARNING! Improper installation, adjustment, alteration, service or maintenance can cause injury or property damage.** Refer to owner's information manual provided with this heater.

**NOTICE!** This appliance is not intended for use as a primary heat source and should not be factored as such in residential heating calculations.

When using electrical appliances, basic precautions should always be followed to reduce the risk of fire, electric shock, and injury to persons, including the following:

- Read all instructions before installing this appliance.
- This appliance is hot when in use. To avoid burns, do not let bare skin touch hot surfaces. Keep combustible materials such as furniture, pillows, bedding, papers, clothes, etc. and curtains at least 3 ft. (0.9 m) from the front of the appliance and keep them away from the sides and rear
- Extreme caution is necessary when any appliance is used by or near children or invalids and whenever the appliance is left operating and unattended.
- Do not operate any appliance if it malfunctions. Disconnect power at service panel and have appliance inspected by a reputable electrician before reusing.
- Do not insert or allow foreign objects to enter any ventilaion or exhaust opening as this may cause an electric shock or fire, or damage the appliance.
- To prevent a possible fire, do not block appliance connection fan air intakes or exhaust in any manner.
- A appliance has hot and arcing or sparking parts inside. Do not use it in areas where gasoline, paint, or flammable vapors or liquids are used or stored.
- Use this appliance only as described in this manual. Any other use not recommended by the manufacturer may cause fire, electric shock, or injury to persons.
- Do not operate any appliance with a damaged cord or plug or after the appliance malfunctions, has been dropped or damaged in any manner. Return appliance to authorized service facility for examination, electrical or mechanical adjustment or repair.
- Do not use outdoors.
- The appliance is not intended for use in bathrooms, laundry areas and similar indoor locations. Never locate appliance where it may fall into a bathtub or water container.
- Do not run cord under carpeting. Do not cover cord with throw rugs, runners, or the like. Arrange cord away from traffic areas and where it will not be tripped over. Do not tightly coil cord.
- Always use properly grounded, fused and polarized outlets.
- Always use ground fault protection where required by electrical code.
- To disconnect appliance, turn controls to "OFF" then remove plug from outlet.
- Always disconnect power before performing any cleaning, maintenance or relocation of the appliance.
- To prevent a possible fire, do not burn wood or other materials in this appliance.
- To prevent electrical shock or fire, always use a certified electrician should new circuits be required.
- When transporting or storing the appliance, keep in a dry place free from excess vibration and store to avoid damage.
- Avoid use of an extension cord because an extension cord may overheat and cause a fire. However if you have to use an extension cord, the cord should be No. 14 AWG minimum size and rated to not less than 1875 watts.

**SAVE THESE INSTRUCTIONS**

**▲ Safety Alert Key:**

- **WARNING!** Indicates a hazardous situation which, if not avoided could result in death or serious injury.
- **CAUTION!** Indicates a hazardous situation which, if not avoided, could result in minor or moderate injury.

## Table of Contents

### 1 IMPORTANT INSTRUCTIONS

A. Important Instructions . . . . . 2  
B. Warranty . . . . . 4

### 2 GENERAL INFORMATION

A. Appliance Certification . . . . . 5  
B. California . . . . . 5  
C. Unpacking and Inspecting Appliance . . . . . 5  
D. Model and Serial Number Information . . . . . 5

### 3 GETTING STARTED

A. Parts and Hardware . . . . . 6  
B. Tools and Supplies Needed . . . . . 6  
C. Appliance Dimensions . . . . . 6  
D. Location . . . . . 7  
E. Clearance to Combustibles . . . . . 7  
F. Electrical Supply Circuit Requirements . . . . . 7

### 4 INSTALLATION

A. Wall Mounting Bracket . . . . . 8  
B. Installing Wall Mount Bracket . . . . . 9  
C. Appliance Installation . . . . . 11  
D. Faux Stone Installation . . . . . 11  
E. Glass Front Installation . . . . . 12  
F. Electrical Connection . . . . . 12

### 5 OPERATING INSTRUCTIONS

A. Manual Switch Function . . . . . 13  
B. Operating by Remote Control . . . . . 14  
C. Resetting Temperature Cutoff Switch . . . . . 14

### 6 MAINTENANCE

A. Maintenance . . . . . 15  
B. Cleaning . . . . . 15  
C. Servicing . . . . . 15  
D. Service Parts List . . . . . 16

## B. Warranty

### Hearth & Home Technologies LLC LIMITED LIFETIME WARRANTY

Hearth & Home Technologies LLC (“HHT”) extends the following warranty for HHT gas, wood, pellet and electric hearth appliances (each a “Product” and collectively, the “Product(s)”) and certain component parts set forth in the table below (“Component Part(s)”) that are purchased from a HHT authorized dealer or distributor.

#### **WARRANTY COVERAGE:**

HHT warrants that the Products and their Component Parts will be free from defects in materials and workmanship for the applicable period of Warranty coverage set forth in the table below (“Warranty Period”). If a Product or Component Parts are found to be defective in materials or workmanship during the applicable Warranty Period, HHT will, at its option, repair the applicable Component Part(s), replace the applicable Component Part(s), or refund the purchase price of the applicable Product(s). The maximum amount recoverable under this Warranty is limited to the purchase price of the Product. This Warranty is transferable from the original purchaser to subsequent owners, but the Warranty Period will not be extended in duration or expanded in coverage for any such transfer. This Warranty is subject to conditions, exclusions, and limitations as described below.

#### **WARRANTY PERIOD:**

Warranty coverage begins at the date of installation. In the case of new home constructions, Warranty coverage begins on the date of first occupancy of the dwelling or six months after the sale of the Product(s) by an independent, authorized HHT dealer or distributor, whichever occurs earlier. However, the Warranty coverage shall commence no later than 24 months following the date of Product shipment from HHT, regardless of the installation or occupancy date.

The term “Lifetime” in the table below is defined as: 20 years from the beginning date of warranty coverage for gas appliances, and 10 years from the beginning date of warranty coverage for wood and pellet appliances. These time periods reflect the minimum expected useful lives of the designated Component Parts under normal operating conditions.

Warranty Period		HHT Manufactured Appliances and Venting					
Component Parts	Labor	Gas	Pellet	Wood	Electric	Venting	Component Parts Covered by this Warranty
1 Year		X	X	X		X	All parts including handles, external enameled components and other material except as covered by Warranty Conditions, Warranty Exclusions, and Warranty Limitations listed
2 Years					X		All parts except as covered by Warranty Conditions, Warranty Exclusions, and Warranty Limitations listed
2 years			X	X			Igniters, Auger Motors, Electronic Components, and Glass
		X					Electrical components limited to modules, remotes/wall switches, valves, pilots, blowers, junction boxes, wire harnesses, transformers and lights (excluding light bulbs)
		X		X			Molded Refractory Panels, Glass Liners
3 years			X				Firepots, burnpots, mechanical feeders/auger assemblies
5 years	1 year	X					Vent Free Burners, Vent Free Logs
			X	X			Castings, Medallions and Baffles
6 years	3 years			X			Catalysts
7 years	3 years		X	X			Manifold tubes, HHT Chimney and Terminations
10 years	1 year	X					Burners, logs and refractory
Limited Lifetime	3 years	X	X	X			Firebox and heat exchanger, FlexBurn® System (engine, inner cover, access cover and fireback)
1 Year	None	X	X	X	X	X	All purchased replacement parts

## **WARRANTY CONDITIONS:**

- Because HHT cannot control the quality of any Products sold by unauthorized sellers, this Warranty only covers Products that are purchased through an HHT authorized dealer or distributor unless otherwise prohibited by law; a list of HHT authorized dealers is available on the HHT branded websites.
- This Warranty is only valid while the applicable Product remains at the site of original installation.
- This Warranty is only valid in the country in which the HHT authorized dealer or distributor that sold the applicable Product is authorized to sell applicable Product.
- Contact your installing distributor or dealer for Warranty service. If the installing dealer or distributor is unable to provide necessary parts, contact the nearest HHT authorized dealer or supplier. Additional service fees may apply if you are seeking Warranty service from a dealer other than the dealer from whom you originally purchased the applicable Product.
- No HHT consumer should bear cost of warranty service or costs incurred while servicing warranty claims (i.e., travel, gas, or mileage) when the service is performed within the terms of this Warranty. Check with your dealer or distributor in advance for any costs to you when arranging a warranty call. Travel and shipping charges for parts are not covered by this Warranty.

## **WARRANTY EXCLUSIONS:**

This Warranty does not cover the following:

- Changes in surface finishes as a result of normal use. As a heating appliance, some changes in color of interior and exterior surface finishes may occur. This is not a flaw and is not covered under the Warranty.
- Damage to printed, plated, or enameled surfaces caused by fingerprints, accidents, misuse, scratches, melted items or other external sources and residues left on the plated surfaces from the use of abrasive cleaners or polishes.
- Repair or replacement of parts that are subject to normal wear and tear during the Warranty Period are not covered. These parts include: paint, wood and pellet gaskets, firebricks, grates, flame guides, batteries and the discoloration of glass.
- Minor expansion, contraction, or movement of certain parts causing noise. These conditions are normal and complaints related to this noise are not covered by this Warranty.
- Damages resulting from: (1) failure to install, operate, or maintain the applicable Product in accordance with the installation instructions, operating instructions, and listing agent identification label furnished with the applicable Product; (2) failure to install the applicable Product in accordance with local building codes; (3) shipping or improper handling; (4) improper operation, abuse, misuse, continued operation with damaged, corroded or failed components, accident, or improperly/incorrectly performed repairs; (5) environmental conditions, inadequate ventilation, negative pressure, or drafting caused by tightly sealed constructions, insufficient make-up air supply, or handling devices such as exhaust fans or forced air furnaces or other such causes; (6) use of fuels other than those specified in the operation instructions; (7) installation or use of components not supplied with the applicable Product or any other components not expressly authorized and approved by HHT; (8) modification of the appliance not expressly authorized and approved by HHT in writing; and/or (9) interruptions or fluctuations of electrical power supply to the applicable Product.
- Non-HHT venting components, hearth connections or other accessories used in conjunction with the applicable Product.
- Any part of a pre-existing fireplace system in which an insert or a decorative gas applicable Product is installed.
- HHT's obligation under this Warranty does not extend to the Product's capability to heat the desired space. Information is provided to assist the consumer and the dealer in selecting the proper Product for the application. Consideration must be given to the Product location and configuration, environmental conditions, insulation and air tightness of the structure.

### **This warranty is void if:**

- The applicable Product has been over-fired, operated in atmospheres contaminated by chlorine, fluorine, or other damaging chemicals. Over-firing can be identified by, but not limited to, warped plates or tubes, deformation/warping of interior cast iron structure or components, rust colored cast iron, bubbling, cracking and discoloration of steel or enamel finishes.
- The applicable Product is subjected to prolonged periods of dampness or condensation.
- There is any damage to the applicable Product due to water or weather damage which is the result of, but not limited to, improper chimney or venting installation.

## **LIMITATIONS OF REMEDIES AND LIABILITY:**

- **EXCEPT TO THE EXTENT PROVIDED BY LAW, HHT MAKES NO EXPRESS WARRANTIES OTHER THAN THE WARRANTY SPECIFIED HEREIN. The owner's exclusive remedy and HHT's sole obligation under this Warranty or in contract, tort or otherwise, shall be limited to replacement of the Component Part(s), repair of the Component Part(s), or refund of the original purchase price of the applicable Product(s), as specified above; provided, however, that (i) if HHT is unable to provide replacement of the Component Part(s) and repair of the Component Part(s) is not commercially practicable or cannot be timely made, or (ii) the customer is willing to accept a refund of the purchase price of the applicable Product(s), HHT may discharge all such obligations by refunding the purchase price of the applicable Product. In no event will HHT be liable for any incidental or consequential damages caused by defects in the applicable Product. Some States do not allow the exclusion or limitation of incidental or consequential damages, so the above limitation or exclusion may not apply to you. This Warranty gives you specific legal rights and you may also have other rights which vary from State to State. THE DURATION OF ANY IMPLIED WARRANTY IS LIMITED TO DURATION OF THE EXPRESSED WARRANTY SPECIFIED ABOVE FOR THE APPLICABLE PRODUCT. Some States do not allow limitations on how long an implied warranty lasts, so the above limitation may not apply to you.**

# 2 GENERAL INFORMATION

## A. Appliance Certification

**MODELS:** SF-WM58-WH, SF-WM58-BK, SF-WM70-BK,  
SF-WM94-BK

**LABORATORY:** CSA International

**TYPE:** Electric Air-Heaters Fixed and Location-Dedicated  
Electric Room Heaters

**STANDARD:** UL 2021 (2<sup>nd</sup> Edition) CSA C22.2 No 46-M1988

**NOTICE:** This installation must conform with local codes.

### NOT INTENDED FOR USE AS A PRIMARY HEAT SOURCE.

This appliance is tested and approved as either supplemental room heat or as a decorative appliance. It should not be factored as primary heat in residential heating calculations.

**Note:** The device complies with Part 15 of the FCC Rules. Operation is subject to the following two conditions:

1. This device may not cause harmful interference, and
2. This device must accept any interference received, including interference that may cause undesired operation.

This equipment uses and can radiate radio frequency energy and, if not installed and used in accordance with the instructions, may cause harmful interference to radio or television reception, which can be determined by turning the equipment off and on. The user is encouraged to try to correct the interference by one or more of the following measures:

- Increase the separation between the equipment and the receiver.
- Connect the equipment into an outlet on a circuit different from that to which the receiver is connected.

## B. California



**WARNING:** This product can expose you to Di-(2-ethyl hexyl) phthalate, which is known to the State of California to cause cancer and reproductive harm. For more information go to: [www.P65Warnings.ca.gov](http://www.P65Warnings.ca.gov).

## C. Unpacking and Inspecting Appliance

**WARNING! DO NOT use this Electric Fireplace if any part has been under water.** Immediately call a qualified service technician to inspect and to replace any part of the electrical system if necessary. Keep plastic wrapping away from children.

- Carefully remove the appliance and components from the packaging. Discard packaging.
- Carefully inspect components for any damage.
- Reference parts list to verify all parts have been received.
- Read all the instructions before starting the installation. Follow these instructions carefully during the installation to ensure maximum safety and benefit.

## D. Model and Serial Number Information

The model and serial number information is located on the rating plate. The rating plate is located on the left side of the top surface of the appliance.

### ELECTRIC FIREPLACE

**MODEL** SF-WM58  
**VOLTAGE** 120V AC  
**FREQUENCY** 60 Hz  
**AMPERAGE** 12.5 A  
**WATTS** 1500 W  
**SERIAL NO.:**



MADE IN CHINA

### ELECTRIC FIREPLACE

**MODEL** SF-WM70  
**VOLTAGE** 120V AC  
**FREQUENCY** 60 Hz  
**AMPERAGE** 12.5 A  
**WATTS** 1500 W  
**SERIAL NO.:**



MADE IN CHINA

### ELECTRIC FIREPLACE

**MODEL** SF-WM94  
**VOLTAGE** 120V AC  
**FREQUENCY** 60 Hz  
**AMPERAGE** 12.5 A  
**WATTS** 1500 W  
**SERIAL NO.:**



MADE IN CHINA

## Homeowner Reference Information

We recommend that you record the following pertinent information about your fireplace.

Model Name: \_\_\_\_\_ Date purchased/installed: \_\_\_\_\_

Serial Number: \_\_\_\_\_ Location on fireplace: \_\_\_\_\_

Dealership purchased from: \_\_\_\_\_ Dealer Phone: \_\_\_\_\_

Notes: \_\_\_\_\_

# 3 GETTING STARTED

## A. Parts and Hardware

Parts and Hardware List	
Part	Quantity
Fan Box	1
Glass	1
Instruction Manual	1
Remote Control	1
AAA Battery	2
Wall Mounting Bracket (attached to unit)	1
Masonry Anchor	
SF-WM58	6
SF-WM70	8
SF-WM94	10
Screw ST6 x 50	
SF-WM58	6
SF-WM70	8
SF-WM94	10
Bolt M4 x 8	2
Bolt M5 x 10 (attached to unit)	2
White Stones	1
Clear Faux Stones	1
3/16 Toggle Bolt Anchor	4

## B. Tools and Supplies Needed

Before beginning the installation be sure that the following tools and building supplies are available.

- Tape measure
- Pliers
- Hammer
- Gloves
- Level
- Magnetic Phillips screwdriver
- Safety glasses
- Flat blade screwdriver
- Drill
- 5/16 Drill for 3/16 diameter toggle bolts (applicable if installing on drywall-sheathed walls)
- Masonry Drill 5/16 in. (applicable if installing on masonry walls)

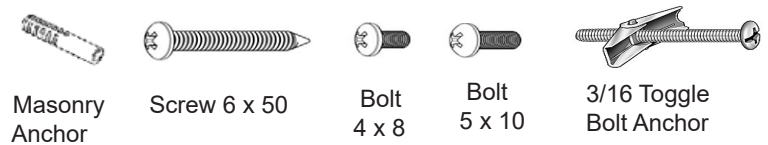

## C. Appliance Dimensions

**Note:** Side view dimensions include mounting bracket.

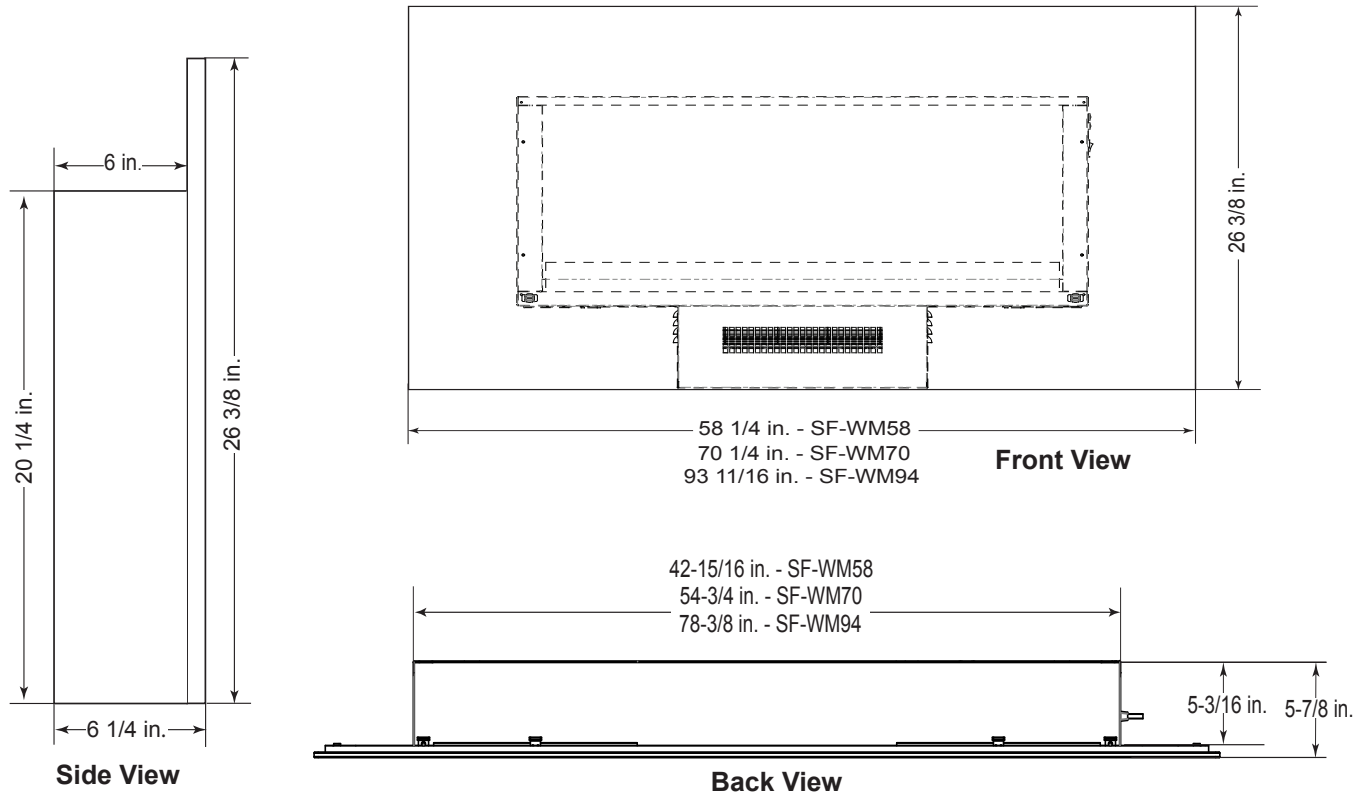

Figure 3.1 Appliance Dimensions



## D. Location

When choosing a location for your fireplace ensure that the general rules are followed:

- For best results, install out of direct sunlight.
- Power supply service must be installed within proximity of electric fireplace prior to finishing to avoid reconstruction.
- See Figure 3.1 for appliance dimensions and to determine location of appliance installation.

## E. Clearance to Combustibles

### Minimum Clearance to Combustible Construction

Sides.....	0 in.
Floor.....	13 3/4 in.
Top.....	0 in.
Back.....	0 in.
Front.....	36 in.

See Figure 3.2.

**WARNING! Risk of Fire!** Keep electrical cords, drapery, furnishings or other combustibles at least 3 ft. (0.9 m) from the front of the electric fireplace, and away from the sides or rear.

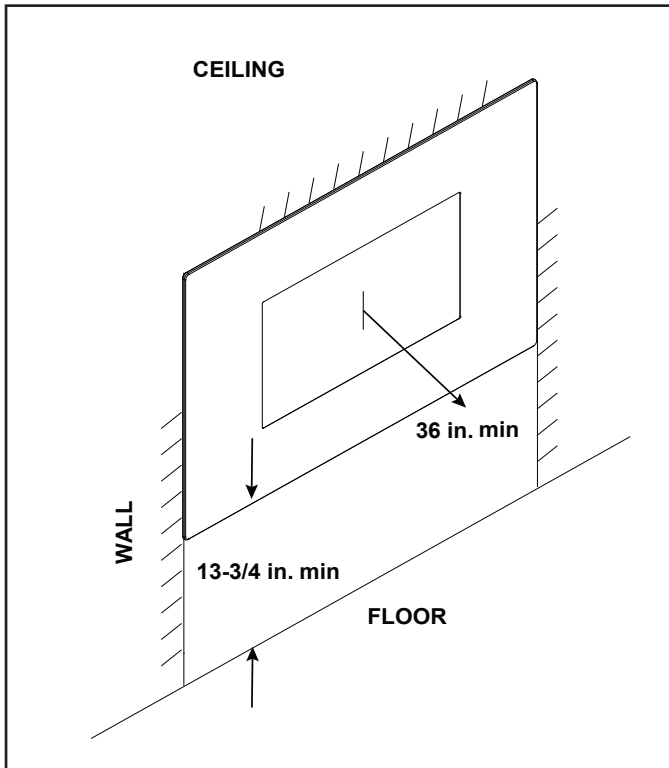

Figure 3.2 Clearance to Combustibles

## F. Electrical Supply Circuit Requirements

Plan the location of the appliance so that it will have adequate electric power. A 15 AMP, 120V/60hz circuit is required. Additional appliances on the same circuit as this appliance may exceed the current rating of that circuit. A dedicated circuit is not required, but is preferred to prevent circuit breaker trips or fuse failure.

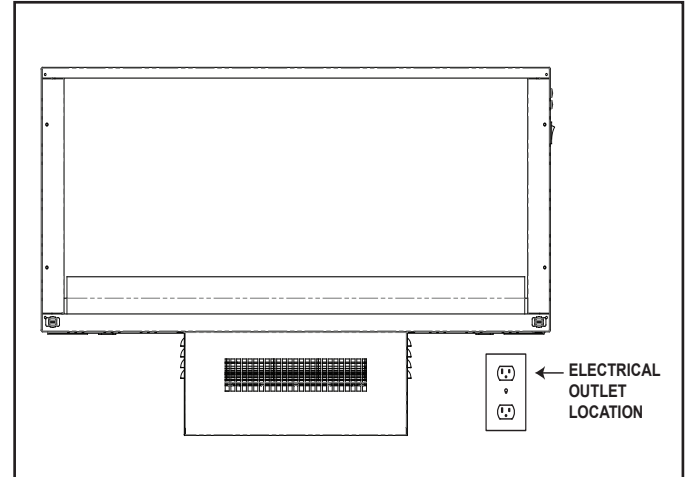

Figure 3.3 Electrical Outlet Location



# 4 INSTALLATION

**WARNING! Risk of Personal Injury or Property Damage!** Failure to install the appliance as instructed below may result in damage to the equipment and or may expose the user to the risk of fire, serious injury, illness or death.

## A. Wall Mounting Bracket

### SF-WM58

The wall mounting bracket must be used to mount the appliance. This appliance must be mounted to a structural wall capable of bearing an 85 pound load.

- Remove bracket from back of unit.
- Determine the desired location of the appliance on the wall depending on the size of unit.

**Note:** If installing on non-masonry wall, place the wall mounting bracket in the desired location that also aligns at least **two** required mounting points (screws 6 x 50) with a structural framing member.

If installing on masonry wall, proceed to page 10 for installation instructions.

- Ensure that the bracket is level.
- Mark six locations on the wall that correspond to the six required mounting points in the bracket. See Figure 4.1 & 4.7.
- Orientate the bracket so that its mounting hooks are pointing up as shown in Figure 4.10 and 4.13.
- Fasten the bracket to the wall.

**Note:** The bracket installation method varies depending on the wall construction (See Section B).

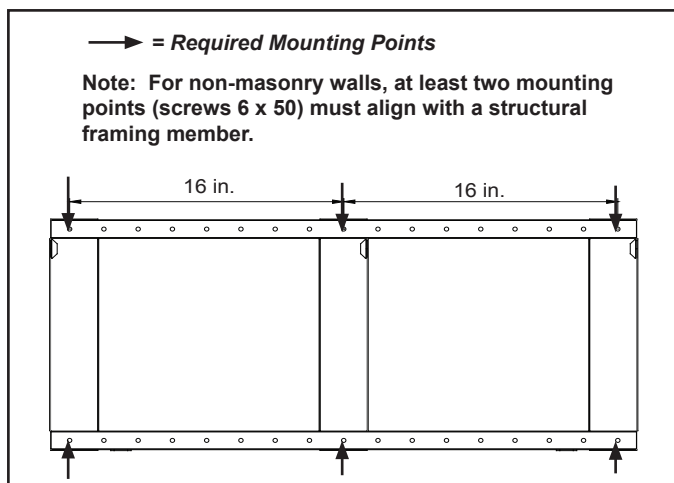

Figure 4.1 SF-WM58 Mounting Bracket

### SF-WM70

The wall mounting bracket must be used to mount the appliance. This appliance must be mounted to a structural wall capable of bearing a 110 pound load.

- Remove bracket from back of unit.
- Determine the desired location of the appliance on the wall depending on the size of unit.

**Note:** If installing on non-masonry wall, place the wall mounting bracket in the desired location that also aligns at least **four** required mounting points (screws 6 x 50) with a structural framing member.

If installing on masonry wall, proceed to page 10 for installation instructions.

- Ensure that the bracket is level.
- Mark eight locations on the wall that correspond to the eight required mounting points in the bracket. See Figure 4.2 & 4.8.
- Orientate the bracket so that its mounting hooks are pointing up as shown in Figure 4.11 and 4.13.
- Fasten the bracket to the wall.

**Note:** The bracket installation method varies depending on the wall construction (See Section B).

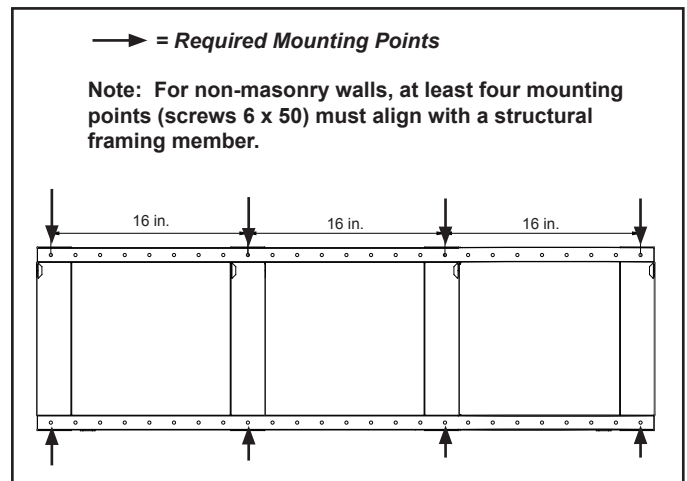

Figure 4.2 Mounting Bracket

## SF-WM94

The wall mounting bracket must be used to mount the appliance. This appliance must be mounted to a structural wall capable of bearing a 135 pound load.

- Remove bracket from back of unit.
- Determine the desired location of the appliance on the wall depending on the size of unit.

**Note:** If installing on non-masonry wall, place the wall mounting bracket in the desired location that also aligns at least **six** required mounting points (screws 6 x 50) with a structural framing member.

If installing on masonry wall, proceed to page 10 for installation instructions.

- Ensure that the bracket is level.
- Mark ten locations on the wall that correspond to the ten required mounting points in the bracket. See Figure 4.3 & 4.9.
- Orientate the bracket so that its mounting hooks are pointing up as shown in Figure 4.12 and 4.13.
- Fasten the bracket to the wall.

**Note:** The bracket installation method varies depending on the wall construction (See Section B).

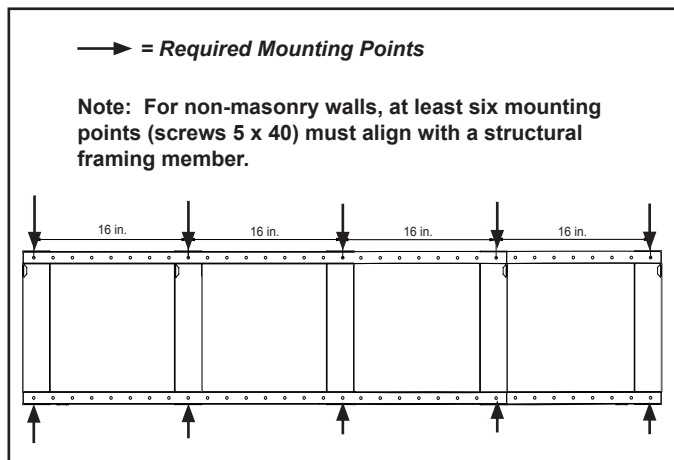

Figure 4.3 Mounting Bracket

## B. Installing Wall Mount Bracket

The wall mounting bracket can be installed on masonry walls such as those constructed of brick or concrete, or to framed walls constructed of wood or steel framing sheathed with gypsum drywall, wood, etc. The method used to mount the mounting bracket is different between masonry walls and framed walls. Refer to the following sections for more detail on the method applicable to this installation.

### Framed Wall

- For each of the marked mounting point locations, determine which points align with a structural framing member.
- At the points where a wood or metal framing member exists, the 6 x 50 screw can be installed directly into that structural member.
- Every mounting hole that does not align with a structural framing member, a wall board toggle-bolt anchor must be used. See Figure 4.4.

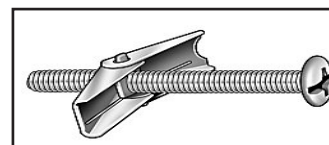

Figure 4.4 3/16 Toggle-Bolt Anchor

- The toggle-bolt anchors are provided to accommodate the required anchor points based on the appliance. Use of toggle bolt anchors requires drywall thickness of minimum 1/2 in.
- Insert the bolt through the front side of the mounting bracket and thread the toggle onto it from the rear of the bracket. See Figure 4.5.
- Fold the toggle wings flush against the bolt and push them through a drilled hole until they expand open on the other side. See Figure 4.6.
- Pull back on the bolt and tighten. See Figure 4.6.

**Note:** This product cannot be installed on a wall sheathed with drywall less than 1/2 in. thick, unless all six anchor points in the mounting bracket align with structural framing members.

**WARNING! Risk of Damage or Personal Injury!** Allowable pull-out and shear strength are 25% of ultimate values or less, as required by building authorities.



Figure 4.5 Toggle Bolt Installation through Mounting Bracket



Figure 4.6 Installing Anchors in Hollow Wall

### Masonry Wall

- In the marked locations, drill 5/16 in. diameter x 2 in. deep holes. See Figure 4.7 (SF-WM58), Figure 4.8 (SF-WM70) or Figure 4.9 (SF-WM94).
- Insert the provided wall anchors into the holes.
- Gently tap the anchors with a hammer until they are flush with the wall surface.
- With mounting hooks pointed up, attach the bracket to the masonry anchors with 6 x 50 screws. See Figure 4.10 (SF-WM58), Figure 4.11 (SF-WM70) or Figure 4.12 (SF-WM94).

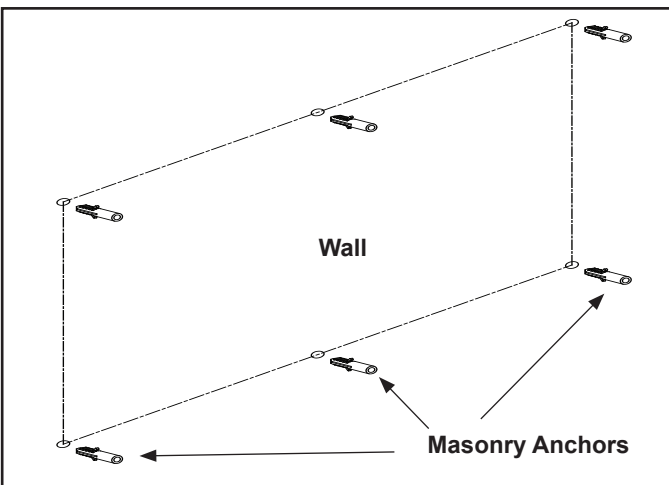

Figure 4.7 (SF-WM58) Masonry Anchor Placement

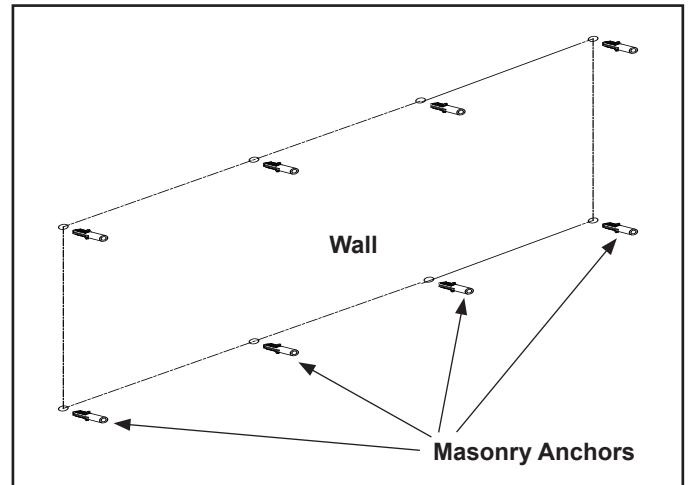

Figure 4.8 (SF-WM70) Masonry Anchor Placement

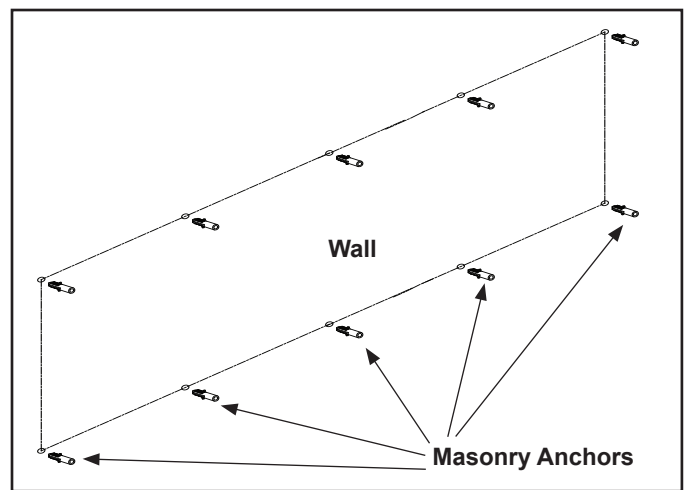

Figure 4.9 (SF-WM94) Masonry Anchor Placement

**WARNING! Risk of Damage or Personal Injury!** Do not use supplied masonry anchors on hollow walls, sheathed with wood, sheetrock, drywall or other materials.

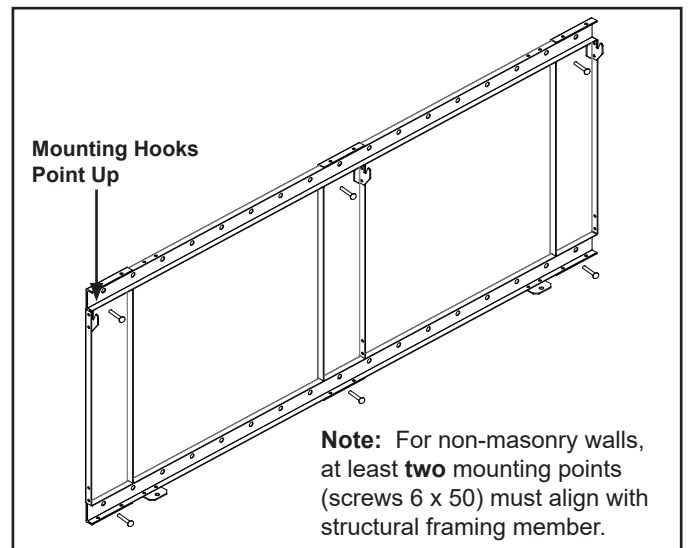

Figure 4.10 (SF-WM58) Bracket Attachment

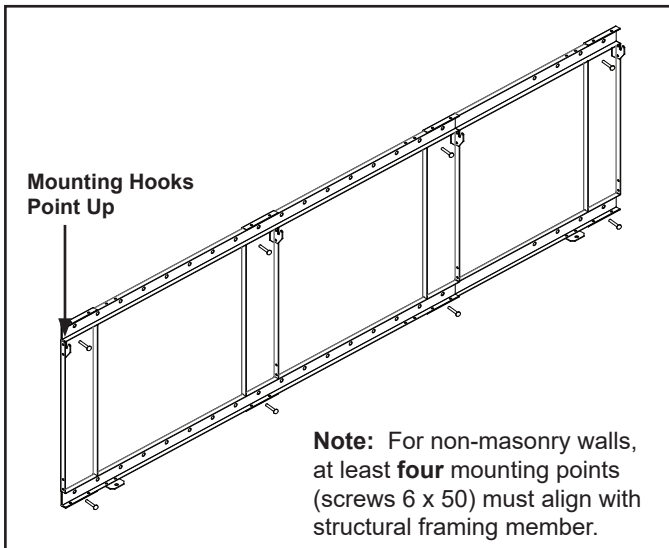

Figure 4.11 (SF-WM70) Bracket Attachment

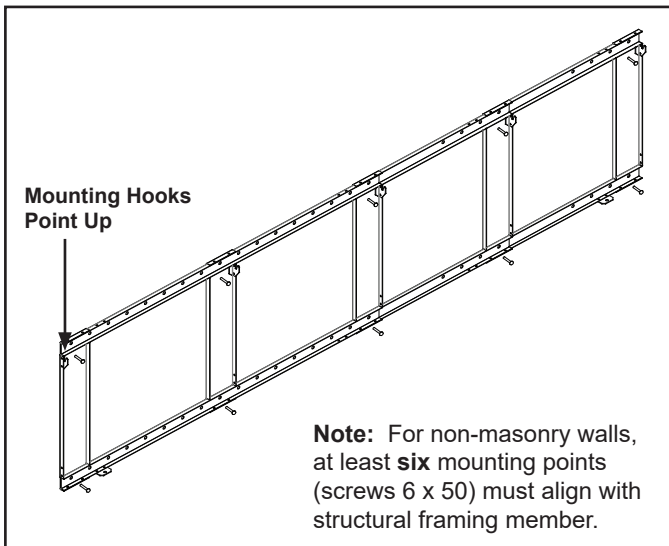

Figure 4.12 (SF-WM94) Bracket Attachment

## C. Appliance Installation

- Hang appliance on the mounting bracket.
- Align the slots on the back of the appliance with the hooks on the top two corners of the bracket.
- Hang the appliance and pull down to ensure the hooks are fully engaged. See Figure 4.13.
- Secure the appliance to the bracket with two M5x10 screws. See Figure 4.13.

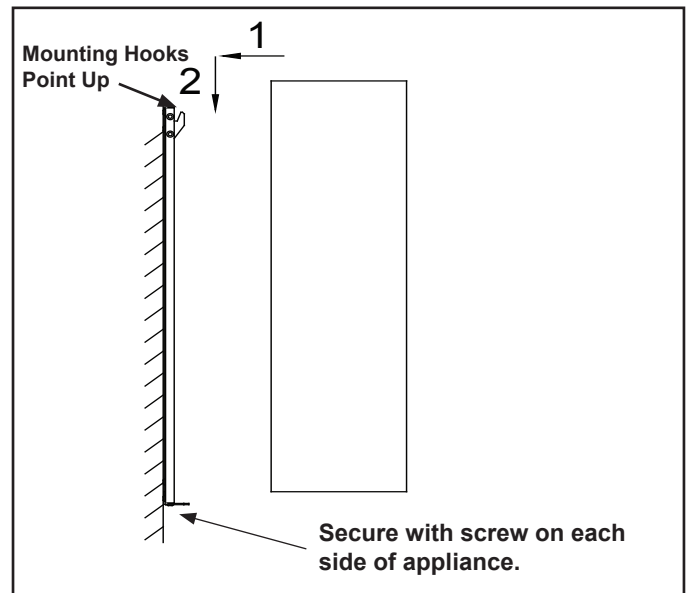

Figure 4.13 Attaching Appliance to Bracket

## D. Faux Stone Installation

- Arrange the white and clear faux stones along the inset window ledge at the front of the appliance.
- Place clear stones over LED bulbs and fill remaining gaps with white stones.

**Note:** Extra stones are provided and may be distributed based on consumer preference. Not all stones need to be used.

## E. Glass Front Installation

**CAUTION! Risk of Injury!** It is recommended that Glass assembly installation and removal be performed by two people.

- Install glass front as shown in Figure 4.14. Orientate front so that LED lighting connector is towards the floor.
- Install glass front so that the tabs on its back side engage the slots in the top of the appliance.
- Once both tabs engage, press firmly against the bottom face of the glass panel to engage the bottom connectors.

**Note:** The tabs on the two center mounting brackets on the glass will not fully engage the corresponding slots in the appliance.

- Secure the glass front to the appliance with two provided M4x8 screws through the two glass front mounting brackets. See Figure 4.14.
- Connect the electrical cable from the glass front backlighting to the corresponding cable on the lower right of the appliance. Note: The backlight cable plug on the appliance is accessed by removing its access cover on the lower right of the appliance.

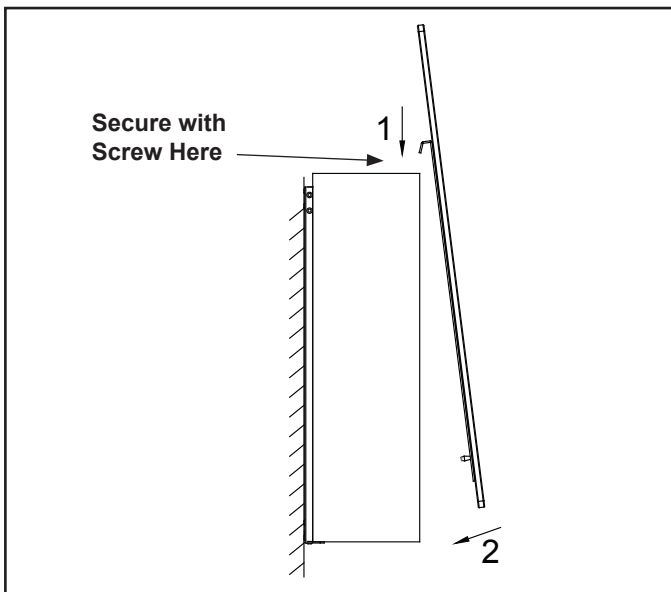

Figure 4.14 Attaching Front to Appliance

## F. Electrical Connection

**WARNING! Risk of Fire, Electrical Shock and Injury!** Electrical wiring must comply with local building codes and other applicable regulations to reduce the risk of fire, electrical shock and injury.

A 15 AMP, 120 Volt, 60 Hz. circuit with a properly grounded outlet is required. The unit comes with a 6 ft. long three wire 16AWG IEC-320 power cord.

The appliance power cord has a three pin NEMA-5-15P plug (Figure 4.15A). An adapter must be used for connecting to a two-slot receptacle (Figure 4.15C). The green grounding wire extending from the adapter must be connected to a permanent ground such as a properly grounded outlet box. The adapter should not be used if a three slot grounded receptacle is available.

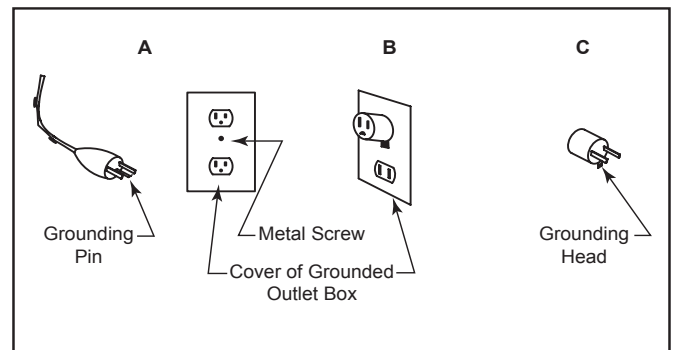

Figure 4.15 Cord Electrical Connection

**WARNING! Risk of Fire!** Do not plug in or operate this product with hot air vents touching the ground. Always hang on wall with supplied bracket before use.

**WARNING! Risk of Fire, Electrical Shock and Injury!** Ensure the power cord is not installed so that it is pinched or against a sharp edge and ensure that the power cord is stored or secure to avoid tripping and snagging.

# 5 OPERATING INSTRUCTIONS

**CAUTION!** The unit's power cord must be connected to a properly grounded and protected 120V outlet. Always use ground fault protection where required by the electrical code.

**WARNING! Risk of Fire, Electrical Shock, and Injury!** Do not operate the unit if it is damaged or has malfunctioned. If you suspect the unit is damaged, call a qualified service technician to inspect and replace any part of the electrical system if necessary.

## A. Manual Switch Function

The appliance can be operated by both remote control and manual button. Once the unit has been properly connected to a grounded electrical outlet, turn on the main power switch located on the right side of the appliance. A beep should be heard when the power is first applied. See Figure 5.1.

### Main Power Switch

The POWER switch supplies power to all functions of the fireplace. This switch must be in the "ON" position for any of the functions including the remote.

**Note:** To use both remote and manual function, the main power switch must be in "ON" position.

### Flame Button

By pressing the FLAME button, the unit will cycle through four flame effects.

### Heater Button

- Press the heater button once to turn 750W power on. Appliance will beep and illuminate 1 red LED.
- Press again turns 1500W power on. Appliance will beep and illuminate 2 red LEDs.
- Press third time turns heater off.

**Note:** A harmless slight brief odor may occur during first use or after prolonged period of storage.

### NOTE:

There is a brief delay between the heater command and the heater turning ON. When the appliance receives a heater ON command, the appliance blower will turn ON for 8 seconds before the heater turns ON. There is also an 8 second delay between heater off and blower shutdown.

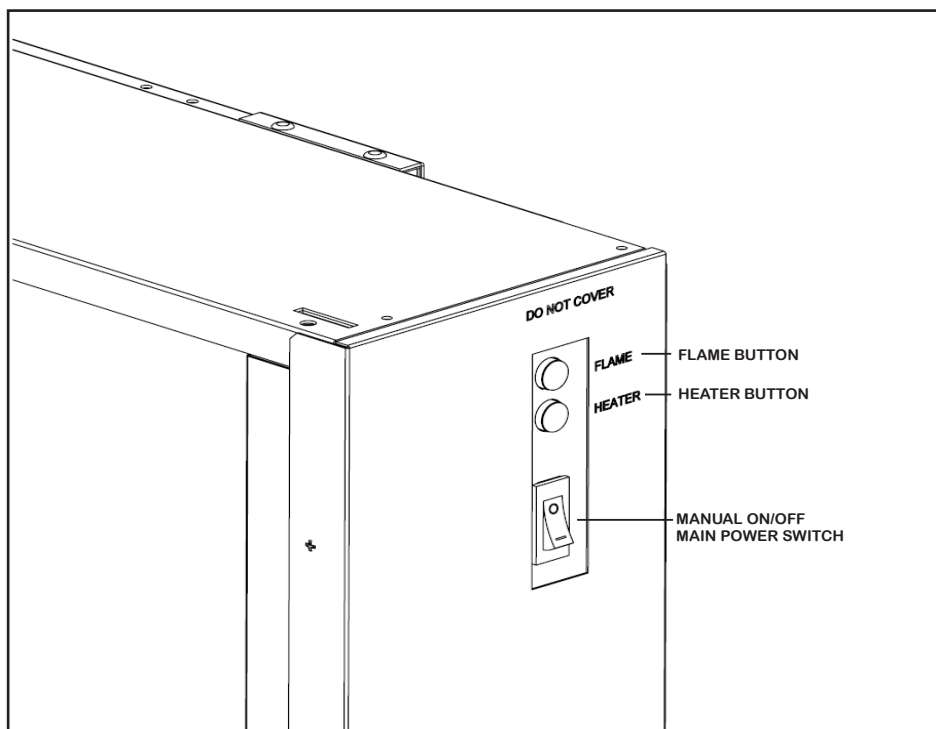

Figure 5.1 Manual Operating Switches



## B. Operating by Remote Control

- The appliance Main Power Switch must be in the “ON” position for the remote control to function.
- Make sure batteries are properly installed in Remote Control.
  - Battery requirements 2 x AAA batteries (included)
- The effective range of the remote is up to 13 ft.
- The remote control must be within the 13 ft. range and also be pointed directly at the face of the appliance. For best results, position the remote control within 45 degrees of the face of the appliance







## C. Resetting Temperature Cutoff Switch

The heater is protected with a safety device to prevent overheating. Should the heater overheat, an automatic cutoff will turn the heater OFF. It will not turn ON automatically without being reset. If it overheats for any reason, it can be reset by:

1. Turn appliance to off
2. Unplug unit and wait 5 minutes
3. Plug in and turn on.

**CAUTION:** If appliance overheats repeatedly, discontinue use and call customer / technical support.

**CAUTION:** If you need to continuously reset the heater, unplug the appliance and contact customer / technical support.

ICON	TITLE	FUNCTION	REMOTE LCD DISPLAY	FIREPLACE RESPONSE
	POWER	The POWER button will turn the fireplace on. It will also put the fireplace in a standby mode. This will turn off all functions at once but will hold the settings in memory except Heater function. The unit will turn on at the same settings by pressing the power button again.	LCD illuminates and displays flame status icon and temperature set point.	Fireplace emits single audible beep to confirm command to transition to ON or STANDBY state
	FLAME	By pressing the FLAME button, the unit will cycle through four flame effects.	LCD illuminates and displays flame status icon.	Fireplace emits single audible beep to confirm command to transition between four FLAME states.
	HEATER	Press Heater button once 750W heater turns on. Press Heater button twice 1500W turns on, Press Heater button three times, turns off heater.	LCD illuminates and displays heater status icon.	Fireplace emits signal audible beep to confirm command to transition between HEATER states. Fireplace displays one red LED for 8 seconds to confirm low heater command. Fireplace displays two red LED for 8 seconds to confirm high heater command.
	THERMOSTAT	Pressing the Temperature button adjusts the heaters response to the ambient temperature conditions in the room. Temperature adjusts from 16 °C - 28 °C (61 °F - 82 °F). Power button must be on to set °C to °F. Hold for 3 seconds and the LCD display from °C to °F.	Remote displays the temperature. If in Stand-by mode, temperature displays but cannot be adjusted.	Fireplace emits single audible beep to confirm command to change desired temperature setpoint.
	TIMER	Pressing the Timer button sets the time desired for the fireplace to run. The Timer can be set from .5 hour up to 9 hours in 1 hour increments.	Remote will display the time setting selected. If in Stand-by mode time will display but cannot be adjusted.	Fireplace emits single audible beep to confirm command to transition between four FLAME states.
	LIGHT	Pressing the Light button changes the glass fascia backlight colors (14 colors available), and turns it on/off.	No indicator.	



# 6 MAINTENANCE

---

## A. Maintenance

**WARNING! Risk of Shock!** Always unplug the cord before moving or servicing. Do not immerse appliance in water.

- Always turn OFF the appliance and disconnect the cord from the electrical outlet before cleaning your appliance.
- Light accumulated dust may be removed from the appliance exterior with a soft cloth or vacuum cleaner.
- Wipe the exterior surfaces of the appliance occasionally with a slightly microfiber cloth using a solution of mild detergent and water. Dry thoroughly before operating the appliance.

**CAUTION!** Do not allow water to run into the interior of the appliance as this could create a fire or electric shock. Always unplug the cord before moving or servicing.

- The fan motor is factory lubricated for life and will not require further lubrication.
- Store appliance in a clean dry place when not in use.

**WARNING! Risk of Fire!** To reduce risk of fire, do not store or use gasoline or any other flammable vapors or liquids in the vicinity of the appliance.

**WARNING! Risk of Electrical Shock!** Any other servicing needed must be performed by an authorized service representative. Do not attempt to service the unit yourself.

## B. Cleaning

### Cleaning Glass

Dust particles can be removed by buffing lightly with a clean dry cloth. Fingerprints and other marks can be cleaned with a cloth dampened with a quality household glass cleaner. The glass should be completely dried with a lint free cloth or paper towel. Do not use abrasive cleaners on glass surface. Do not spray liquids directly onto any surface.

### Metal Surface

Dust particles can be removed by buffing lightly with a clean dry cloth. A damp cloth can be used to clean painted surfaces. Do not use abrasive cleaners. Do not spray liquids directly on to any surface.

## C. Servicing

Except for installation and cleaning described in this manual, an authorized service representative should perform any other servicing.



#1 Black Glass



#2 White Glass

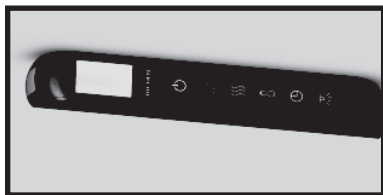

#3 Remote



#4 Fan Box

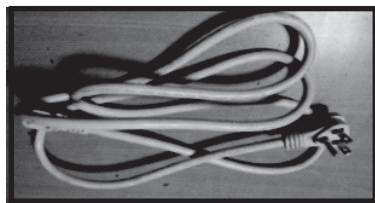

#5 Power cord

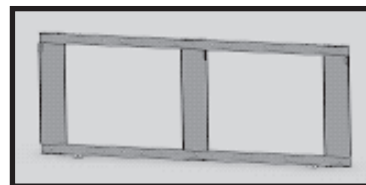

#6 Hanging Bracket

IMPORTANT: THIS IS DATED INFORMATION. Parts must be ordered from a dealer or distributor. **Hearth and Home Technologies does not sell directly to consumers.** Provide model number and serial number when requesting service parts from your dealer or distributor.



**Stocked at Depot**

ITEM	DESCRIPTION	COMMENTS	PART NUMBER	
1	Black Glass		GLA-WM58-BK	
2	White Glass		GLA-WM58-WH	
3	Remote		REMOTE-ELECT-WM	Y
4	Fan Box		FAN-BOX-WM58	Y
5	Power Cord		CORD-WM58	Y
6	Hanging Bracket		BRACKET-WM58	Y
	Flame Rod, 58"		ROD-WM58	
	Rock Kit, Contains both White and Clear Rock		ROCKS-WM58/36	Y
	Hardware Bag		HRDW-WM	Y
	Includes: Masonry Anchors, Screw (ST5 x 40), Bolt (M4 x 8), Bolt (M5 x 10), 3/16 Toggle anchor			
	Grey Screen, 58"		GS-WM58	
	Installation Manual		2040-903	
	Motor, 58", 70", 94"		MOT-WM58/70/94	

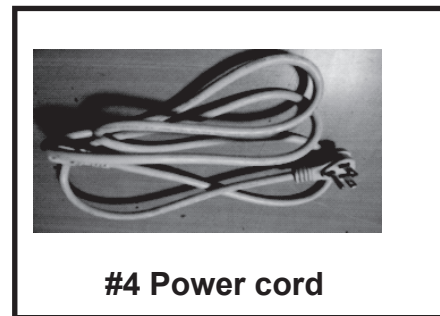
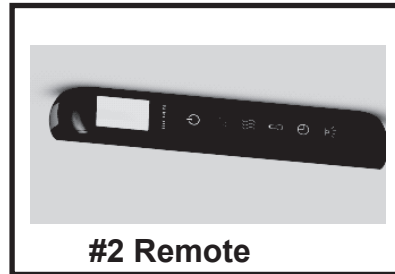
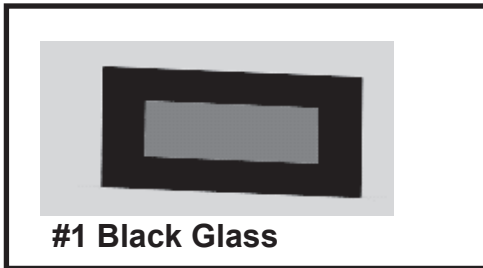

IMPORTANT: THIS IS DATED INFORMATION. Parts must be ordered from a dealer or distributor. **Hearth and Home Technologies does not sell directly to consumers.** Provide model number and serial number when requesting service parts from your dealer or distributor.



Stocked at Depot

ITEM	DESCRIPTION	COMMENTS	PART NUMBER	
1	Black Glass		GLA-WM70-BK	
2	Remote		REMOTE-ELECT-WM	Y
3	Fan Box		FAN-BOX-WM58	Y
4	Power Cord		CORD-WM58	Y
5	Hanging Bracket		BRACKET-WM70	Y
	Flame Rod, 70"		ROD-WM70	
	Rock Kit, Contains both White and Clear Rock		ROCKS-WM70/94	Y
	Hardware Bag		HRDW-WM70/94	Y
	Includes: Masonry Anchors, Screw (ST5 x 40), Bolt (M4 x 8), Bolt (M5 x 10), 3/16 Toggle anchor			
	Grey Screen, 70"		GS-WM70	
	Installation Manual		2040-903	
	Motor, 58", 70", 94"		MOT-WM58/70/94	

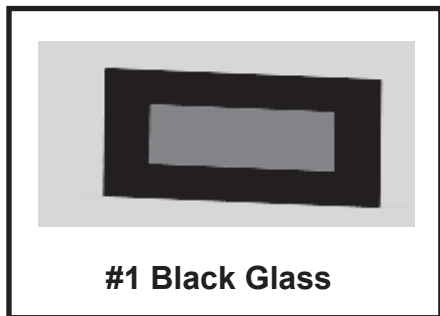

#1 Black Glass

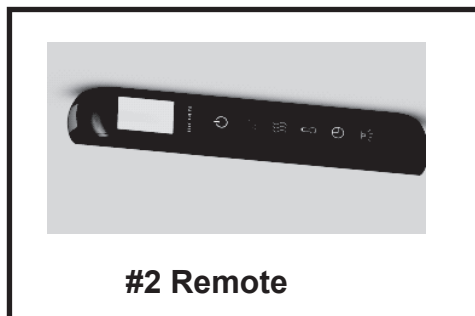

#2 Remote

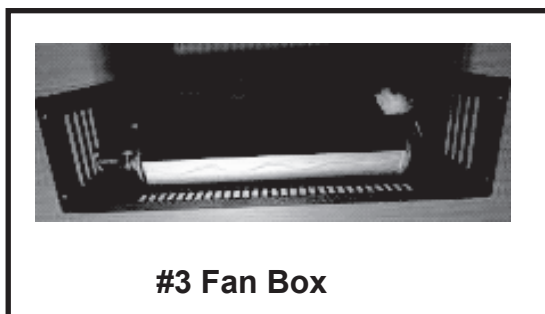

#3 Fan Box

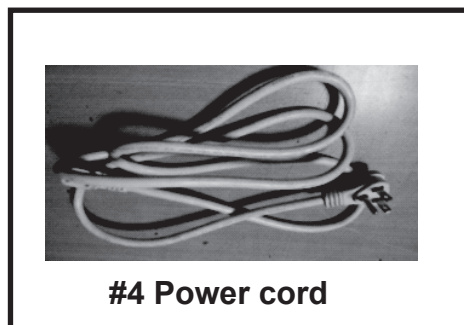

#4 Power cord



#5 Hanging Bracket

IMPORTANT: THIS IS DATED INFORMATION. Parts must be ordered from a dealer or distributor. **Hearth and Home Technologies does not sell directly to consumers.** Provide model number and serial number when requesting service parts from your dealer or distributor.



Stocked  
at Depot

ITEM	DESCRIPTION	COMMENTS	PART NUMBER	
1	Black Glass		GLA-WM94-BK	
2	Remote		REMOTE-ELECT-WM	Y
3	Fan Box		FAN-BOX-WM58	Y
4	Power Cord		CORD-WM58	Y
5	Hanging Bracket		BRACKET-WM94	Y
	Flame Rod, 94"		ROD-WM94	
	Rock Kit, Contains both White and Clear Rock		ROCKS-WM70/94	Y
	Hardware Bag		HRDW-WM70/94	Y
	Includes: Masonry Anchors, Screw (ST5 x 40), Bolt (M4 x 8), Bolt (M5 x 10), 3/16 Toggle anchor			
	Grey Screen, 94"		GS-WM94	
	Installation Manual		2040-903	
	Motor, 58", 70", 94"		MOT-WM58/70/94	