



INSTALLATION MANUAL

Oakville™ Series (GDIG3 illustrated)

SAFETY INFORMATION

! WARNING

FIRE OR EXPLOSION HAZARD

Failure to follow safety warnings exactly could result in serious injury, death, or property damage.

- Do not store or use gasoline or other flammable vapors and liquids in the vicinity of this or any other appliance.

- WHAT TO DO IF YOU SMELL GAS:

- Do not try to light any appliance.
- Do not touch any electrical switch; do not use any phone in your building.
- Immediately call your gas supplier from a neighbour's phone. Follow the gas supplier's instructions.
- If you cannot reach your gas supplier, call the fire department.

- Installation and service must be performed by a qualified installer, service agency, or the supplier.

This appliance may be installed in an aftermarket, permanently located, manufactured home (USA only) or mobile home, where not prohibited by local codes.

This appliance is only for use with the type of gas indicated on the rating plate. This appliance is not convertible for use with other gases, unless a certified kit is used.

INSTALLER:

Leave this manual with the appliance

CONSUMER:

Retain this manual for future reference

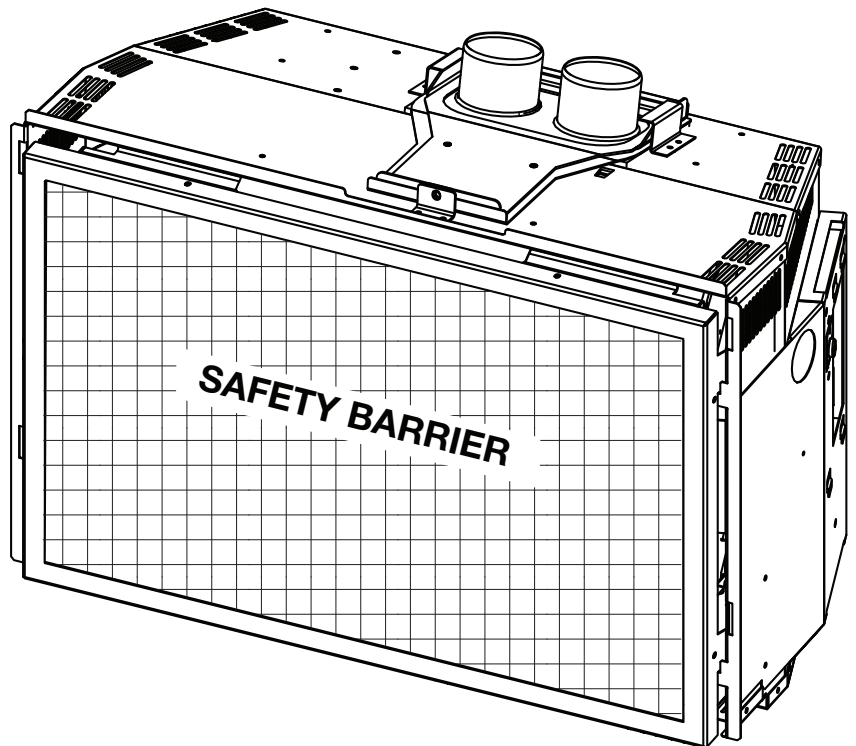

FOR INDOOR USE ONLY

CERTIFIED TO THE CANADIAN AND AMERICAN NATIONAL STANDARDS:
CSA 2.33 AND ANSI Z21.88 FOR VENTED GAS FIREPLACE HEATERS



**PLACE BARCODE LABEL ON THE
OWNER'S MANUAL**

Wolf Steel Ltd., 24 Napoleon Rd., Barrie, ON, L4M 0G8 Canada / 103 Miller Drive, Crittenden, Kentucky, USA, 41030
Phone 1 (866) 820-8686 • www.napoleon.com • hearth@napoleon.com

WARNING

- **This appliance is hot when operated and can cause severe burns if contacted.**
- **Any changes or alterations to this appliance or its controls can be dangerous and is prohibited.**
- Do not operate appliance before reading and understanding operating instructions. Failure to operate appliance according to operating instructions could cause fire or injury.
- Ensure the glass door is opened or removed when lighting the pilot for the first time and when the gas supply has run out.
- Risk of fire or asphyxiation, do not operate appliance with fixed glass removed and never obstruct the front opening of the appliance.
- Do not connect 110 volts to the control valve, with the exception of models; GSST8 and GT8.
- Risk of burns. The appliance should be turned off and cooled before servicing.
- Do not install damaged, incomplete or substitute components.
- Risk of cuts and abrasions. Wear protective gloves, protective footwear, and safety glasses during installation. Sheet metal edges may be sharp.
- Do not burn wood or other materials in this appliance.
- Provide adequate ventilation and combustion air. Provide adequate accessibility clearance for servicing and operating the appliance.
- High pressure will damage valve. Disconnect gas supply piping before pressure testing gas line at test pressures above 1/2 psig. Close the manual shut-off valve before pressure testing gas line at test pressures equal to or less than 1/2 psig (35mb).
- The appliance must not be operated at temperatures below freezing (32°F / 0°C). Allow the appliance to warm to above freezing prior to operation, with the exception of models; GSS36, GSS42; these appliances are suitable for 0°F / -18°C.
- **Children and adults should be alerted to hazards of high surface temperature and should stay away to avoid burns or clothing ignition.**
- **Young children should be carefully supervised when they are in the same room as the appliance. Toddlers, young children and others may be susceptible to accidental contact burns. A physical barrier is recommended if there are at risk individuals in the house. To restrict access to an appliance or stove, install an adjustable safety gate to keep toddlers, young children and other at risk individuals out of the room and away from hot surfaces.**
- **Clothing or other flammable material should not be placed on or near the appliance.**
- **Due to high temperatures, the appliance should be located out of traffic and away from furniture and draperies.**
- Furniture or other objects must be kept a minimum of 4 feet (1.22m) away from the front of the appliance.
- Ensure you have incorporated adequate safety measure to protect infants/toddlers from touching hot surfaces.
- Even after the appliance is off, it will remain hot for an extended period of time.
- Check with your local hearth specialty dealer for safety screens and hearth guards to protect children from hot surfaces. These screens and guards must be fastened to the floor.
- **Any safety screen, guard or barrier removed for servicing the appliance, must be replaced prior to operating the appliance.**
- It is imperative that the control compartments, burners and circulating blower and its passageway in the appliance and venting system are kept clean. The appliance and its venting system should be inspected before use and at least annually by a qualified service person. More frequent cleaning may be required due to excessive lint from carpeting, bedding material, etc. The appliance area must be kept clear and free from combustible materials, gasoline and other flammable vapors and liquids.
- If the appliance shuts off, do not re-light until you provide fresh air. If appliance keeps shutting off, have it serviced. Keep burner and control compartment clean.
- Under no circumstances should this appliance be modified.
- Do not allow wind or fans to blow directly into the appliance. Avoid any drafts that alter burner flame patterns.



DANGER



HOT GLASS WILL CAUSE BURNS.

DO NOT TOUCH GLASS UNTIL COOLED.

NEVER ALLOW CHILDREN TO TOUCH GLASS.

A barrier designed to reduce the risk of burns from the hot viewing glass is provided with this appliance and must be installed for the protection of children and other at-risk individuals.

! WARNING

- Do not use a blower insert, heat exchanger insert or other accessory not approved for use with this appliance.
- This appliance must not be connected to a chimney flue pipe serving a separate solid fuel burning appliance.
- Do not use this appliance if any part has been under water. Immediately call a qualified service technician to inspect the appliance and to replace any part of the control system and any gas control which has been under water.
- Do not operate the appliance with the glass door removed, cracked or broken. Replacement of the glass should be done by a licensed or qualified service person, if equipped.
- Do not strike or slam shut the appliance glass door, if equipped.
- **Only doors / optional fronts certified with the appliance are to be installed on the appliance.**
- Keep the packaging material out of reach of children and dispose of the material in a safe manner. As with all plastic bags, these are not toys and should be kept away from children and infants.
- Carbon or soot should not occur in a vent free appliance as it can distribute into the living area of your home. If you notice any signs of carbon or soot, immediately turn off your appliance and arrange to have it serviced by a qualified technician before operating it again.
- If equipped, the screen must be in place (closed) when the appliance is in operation.
- When equipped with pressure relief doors, they must be kept closed while the appliance is operating to prevent exhaust fumes containing carbon monoxide, from entering into the home. Temperatures of the exhaust escaping through these openings can also cause the surrounding combustible materials to overheat and catch fire.
- Carbon monoxide poisoning may lead to death; early signs of carbon monoxide poisoning resemble the flu, with headache, dizziness and/or nausea. If you have these signs, the appliance may not be working properly. Get fresh air at once! Have appliance serviced. Some people; pregnant women, persons with heart or lung disease, anemia, those under the influence of alcohol, those at high altitudes are more affected by carbon monoxide than others. Failure to keep the primary air opening(s) of the burner(s) clean may result in sooting and property damage.
- As with any combustion appliance, we recommend having your appliance regularly inspected and serviced as well as having a Carbon Monoxide Detector installed in the same area to defend you and your family against Carbon Monoxide (not applicable for outdoor appliances).
- Ensure clearances to combustibles are maintained when building a mantel or shelves above the appliance. Elevated temperatures on the wall or in the air above the appliance can cause melting, discolouration or damage to decorations, a TV or other electronic components.
- **For appliances equipped with a safety barrier; if the barrier becomes damaged, the barrier shall be replaced with the manufacturer's barrier for this appliance.**
- **Installation and repair should be done by a qualified service person. It is imperative that control compartments, burners and circulating air passageways of the appliance be kept clean.**
- For outdoor products only: this appliance must not be installed indoors or within any structure that prevents or inhibits the exhaust gases from dissipating in the outside atmosphere.
- If applicable, the millivolt version of this appliance uses and requires a fast acting thermocouple. Replace only with a fast acting thermocouple supplied by Wolf Steel Ltd.

! WARNING: This product can expose you to chemicals including lead and lead compounds, which are known to the State of California to cause cancer, and chemicals including carbon monoxide, which are known to the State of California to cause birth defects or other reproductive harm. For more information, go to www.P65Warnings.ca.gov.

! WARNING !

FIRE RISK HAZARD / DELAYED IGNITION

High supply pressure will damage the valve / controls.



Disconnect the appliance main gas valve/control from the supply piping when pressure testing that system at pressures in excess of 1/2 psi (3.5 kPa).

Isolate the appliance with its shut off valve during any pressure testing of the supply piping at pressures equal to or less than 1/2 psi (3.5 kPa).

table of contents

1.0	general information	5	7.0	adjustments	30
1.1	rates and efficiencies	6	7.1	pilot burner adjustment	30
1.2	rating plate information	8	7.2	venturi adjustment	30
1.3	operating and lighting instructions	9	7.3	flame characteristics	31
1.4	shut-off valve	9	7.4	optional wall switch	31
1.5	dimensions	10	8.0	maintenance	32
1.6	minimum clearance to combustibles	10	8.1	annual maintenance	33
2.0	installation planning	11	8.2	care of glass	33
2.1	levelling the appliance	11	8.3	care of plated parts	34
2.2	chimney connection	12	8.4	door glass replacement	34
2.3	gas installation	13	8.5	media tray installation	34
3.0	finishing	14	8.6	night light™ replacement (GDIG3 / GDIX3)	35
3.1	minimum combustible mantel clearances	14	8.7	restricting vertical vents	35
3.2	safety barrier & door removal / installation	15	8.8	valve train replacement	36
3.3	log placement	16	9.0	replacement parts	37
3.3.1	log placement for GDI3 / GDI3E	16	9.1	overview	38
3.3.2	log placement for GDIX3	19	9.2	right side access plate assembly	39
3.4	media installation	22	9.3	valve train assembly (GDI3)	40
3.5	logo placement	22	9.4	valve train assembly (GDIG3)	41
3.6	glowing embers	22	9.5	valve train assembly (GDIX3)	42
3.7	charcoal embers	23	9.6	valve train assembly (GDI3E)	43
3.8	battery installation (GDIG3 / GDIX3)	23	9.7	firebox top assembly	44
3.9	battery installation (GDI3E)	23	10.0	troubleshooting (millivolt - GDI3)	45
3.10	receiver removal	24	11.0	troubleshooting (electronic - GDI3E / GDIG3 / GDIX3)	47
3.11	bracket installation for optional F45/60 receiver (GDI3)	24	12.0	warranty	50
4.0	electrical information	25	13.0	notes	51
4.1	wiring diagram (GDIG3 / GDIX3)	25			
4.2	wiring diagram (GDI3E)	26			
5.0	operation (millivolt - GDI3)	27			
6.0	operation (electronic - GDI3E, GDIG3, GDIX3)	28			
6.1	pilot on demand	29			
6.2	ACS switch location (GDI3E)	29			

note:

The information throughout this manual is believed to be correct at the time of printing. Wolf Steel Ltd. reserves the right to change or modify any information within this manual at any time without notice. Changes, other than editorial are denoted by a vertical line in the margin.

Installer: please fill out appliance checklist in the owner's manual.

1.0 general information

When the appliance is installed at elevations above 4,500ft (1372m), and in the absence of specific recommendations from the local authority having jurisdiction, the certified high altitude input rating shall be reduced at the rate of 4% for each additional 1,000ft (305m). Expansion / contraction noises during heating up and cooling down cycles are normal and are to be expected.

This appliance is approved for bathroom, bedroom and bed-sitting room installations and is certified for mobile home installation.

This appliance is field convertible between natural gas (NG) and propane (P). To convert from one to another, consult your authorized dealer / distributor.

This appliance is only for use with the type of gas indicated on the rating plate. This appliance is not convertible for use with other gases, unless a certified kit is used.

note:

A barrier designed to reduce the risk of burns is provided with the appliance and must be installed. Never operate the appliance without the barrier installed.

The protective wrap on plated parts is best removed when the assembly is at room temperature but this can be improved if the assembly is warmed, using a hair dryer or similar heat source. The protective wrap must be removed before operating the appliance.

This appliance is a decorative product. It is not a source of heat and not intended to burn solid fuel.



Batteries must be disposed of according to the local laws and regulations. Some batteries may be recycled, and may be accepted for disposal at your local recycling center. Check with your municipality for recycling instructions.

important:

Some components and/or media are packaged separately and must be installed in accordance with the information in this manual.

general information

1.1 rates and efficiencies

GDI3 / GDI3E

	NG	P
Altitude (FT)	0 - 4500	
Max. Input (BTU/hr)	24,500	
Max. Output (BTU/hr)	13,475	

GDIG3

	NG	P
Altitude (FT)	0 - 4500	
Max. Input (BTU/hr)	24,000	
Max. Output (BTU/hr)	14,808	

GDIX3

	NG	P
Altitude (FT)	0 - 4500	
Max. Input (BTU/hr)	30,000	
Max. Output (BTU/hr)	18,540	

GDI3 / GDI3E / GDIG3 / GDIX3

	NG	P
Min. Inlet Gas Supply Pressure	4.5" W.C. (11mb)	11" W.C. (27mb)
Max. Inlet Gas Supply Pressure	7" * W.C. (17mb)	13" W.C. (32mb)
Manifold Pressure (under Flow Conditions)	3.5 W.C. (9mb)	10" W.C. (25mb)

* Max. inlet pressure not to exceed 13".

! WARNING

- Always light the pilot whether for the first time or if the gas supply has run out, with the glass door opened or removed.
- Provide adequate clearance for servicing and operating the appliance.
- Provide adequate ventilation.
- Never obstruct the front opening of the appliance.
- Objects placed in front of the appliance must be kept a minimum of 48" (121.9cm) from the front face of the appliance.
- Surfaces around and especially above the appliance can become hot. Avoid contact when appliance is operating.
- Fire risk. Explosion hazard.
- High pressure will damage valve. Disconnect gas supply piping before pressure testing gas line at test pressures above 1/2 PSIG. Close the manual shut-off valve before pressure testing gas line at test pressures equal to or less than 1/2 PSIG (35mb).
- Use only Wolf Steel approved optional accessories and replacement parts with this appliance using non-listed accessories (blowers, doors, louvres, trims, gas components, venting components, etc.) could result in a safety hazard and will void the warranty and certification.
- The appliance must not be operated at temperatures below freezing (32°F / 0°C). Allow the appliance to warm, to above freezing prior to operation.
- This appliance has been designed and certified for indoor use only.

THIS GAS APPLIANCE MUST BE INSTALLED AND SERVICED BY A QUALIFIED INSTALLER to conform with local codes. Installation practices vary from region to region and it is important to know the specifics that apply to your area, for example in the state of Massachusetts:

- This product must be installed by a licensed plumber or gas fitter when installed within the commonwealth of Massachusetts.
- The appliance damper must be removed or welded in the open position prior to installation of an appliance insert or gas log.
- The appliance off valve must be a "T" handle gas cock.
- The flexible connector must not be longer than 36 inches (0.9m).
- A carbon monoxide detector is required in all rooms containing gas fired appliances.
- The appliance is not approved for installation in a bedroom or bathroom unless the unit is a direct vent sealed combustion product.

The installation must conform with local codes or, in absence of local codes, the National Gas and Propane Installation Code CSA B149.1 in Canada, or the National Fuel Gas Code, ANSI Z223.1 / NFPA 54 in the United States. Suitable for mobile home installation if installed in accordance with the current standard CAN/CSA Z240MH Series, for gas equipped mobile homes, in Canada or ANSI Z223.1 and NFPA 54 in the United States.

The appliance and its individual shutoff valve must be disconnected from the gas supply piping system during any pressure testing of that system at test pressures in excess of 1/2 psig (35 mb).

The appliance must be isolated from the gas supply piping system by closing its individual manual shutoff valve during any pressure testing of the gas supply piping system at test pressures equal to or less than 1/2 psig (35 mb). When installed with a blower or fan, the junction box must be electrically connected and grounded in accordance with local codes. In the absence of local codes, use the current CSA C22.1 Canadian Electrical Code in Canada or the ANSI / NFPA 70 National Electric Code in the United States. In the case where the blower is equipped with a power cord, it must be connected into a properly grounded receptacle. The grounding prong must not be removed from the cord plug.

The following does not apply to inserts; as long as the required clearance to combustibles is maintained, the most desirable and beneficial location for an appliance is in the center of a building, thereby allowing the most efficient use of the heat created. The location of windows, doors and, the traffic flow in the room where the appliance is to be located should be considered. If possible, you should choose a location where the vent will pass through the house without cutting a floor or roof joist.



We suggest that our gas hearth products be installed and serviced by professionals who are certified in the U.S. by the National Fireplace Institute® (NFI) as NFI Gas Specialists

general information

1.2 rating plate information

Certified to Canadian and American National Standards: **CSA 2.22-XXXX / ANSI Z21.50-XXXX for Vented Decorative Gas Appliances**
 Certifié selon les normes Nationales Canadiennes et Américaines: **CSA 2.22-XXXX / ANSI Z21.50-XXXX pour les Appareils à gaz décoratif à évacuation**

Direct vent, vented gas fireplace. Approved for bedroom, bathroom and bed-sitting room installation. Suitable for mobile home installation. If installed in accordance with the current standard CAN / CSA 2245MH Series gas equipped mobile homes in Canada, or, in the United States, the *Manufactured Home Construction and Safety Standard, ANSI Z21.50 CFR, Part 3010*. When this US Standard is not applicable, use the Standard for Fire Safety Criteria for Manufactured Home Installations, Sites and Communities, *ANSI NFPA 501A*. This appliance must be installed in accordance with local codes, if any; if none, follow the current ANSI Z221.1 or CSA B140. For use with barrier **WXXXX-XXXX**, follow *Installation Instructions*. Four à gaz ventilé. Homologué pour installation dans une chambre à coucher, une salle de bain et un studio. Approuvé pour installation dans une maison mobile (sans installation) conforme aux exigences de la norme CAN / CSA 2245MH Série de maisons mobiles équipées au gaz en vigueur au Canada, ou, aux États-Unis selon la norme *ANSI Z21.50*, *Manufactured Home Construction and Safety Standard*. Dans le cas où cette norme d'États-Unis n'est pas pertinente, utiliser la norme *NFPA 501A, Fire Safety Criteria for Manufactured Home Installations, Sites and Communities*. Installer l'appareil selon les codes ou règlements locaux ou, en l'absence de tels règlements, selon les codes d'installation ANSI Z221.1 ou CSA B140 en vigueur. Utiliser uniquement avec l'écran **WXXXX-XXXX**. Suivre les instructions d'installation.

US Energy Verified
Énergie vérifiée
 REFERENCE# 161746

VENTED DECORATIVE GAS APPLIANCE: NOT A SOURCE OF HEAT, NOT INTENDED FOR USE AS A HEATING APPLIANCE, NOT FOR USE WITH SOLID FUEL.
APPAREIL À GAZ DÉCORATIF À ÉVACUATION: N'EST PAS UNE SOURCE DE CHALEUR; N'EST PAS DESTINÉ À ÊTRE UTILISÉ COMME UN APPAREIL DE CHAUFFAGE; NE CONVIENT PAS AUX COMBUSTIBLES SOLIDES.

FOR USE WITH GLASS DOORS CERTIFIED WITH THIS APPLIANCE ONLY. POUR UTILISATION UNIQUEMENT AVEC LES PORTES EN VERRE CERTIFIÉES AVEC L'APPAREIL.

For natural gas when equipped with No. XX drill size orifice. For propane when equipped with No. XX drill size orifice. Convient au gaz naturel quand l'appareil est muni d'un injecteur de diamètre no. XX. Convient au propane quand l'appareil est muni d'un injecteur de diamètre no. XX.

WARNING: Do not add any material to the appliance which will come in contact with the flames, other than that supplied by the manufacturer with the appliance.
AVERTISSEMENT: N'ajoutez pas à cet appareil aucun matériau devant entrer en contact avec les flammes autre que celui qui est fourni avec cet appareil par le fabricant.

The appliance must be vented using the appropriate Napoleon vent kits. See installation manual for venting specifications. Proper reinstallation and resealing is necessary after servicing the vent-air intake system.
 L'appareil doit être ventilé à l'aide de l'ensemble d'évacuation propre à Napoleon. Référez au manuel d'installation pour les spécifications d'évacuation. Il est nécessaire de bien réinstaller et receller l'évacuation après avoir exécuté l'entretien du système de prise d'air.

Serial Number / N° de Série: **XXXXX** W385-XXXX

MODEL / MODÈLE
 9700539 (WSL) 4001658 (NAC) 4001657 (NGZ) 4001659 (WUSA)

Altitude
 XXXX XXXX XXXX XXXX
 XXXX XXXX XXXX XXXX

Input XXXXXX **Elevation** XXXXXX
Reduced input XXXXXX **Alimentation réduite** XXXXXX
 P4 XXX.X% P4 XXX.X%

Manifold Pressure: 3.5" w.c. (NG) **Manifold Pressure:** 3.5" w.c. (P)
Minimum Supply Pressure: 4.5" w.c. (NG) **Minimum Supply Pressure:** 1.5" w.c. (P)
Maximum Supply Pressure: 7" w.c. (NG) **Maximum Supply Pressure:** 19" w.c. (P)
Pression au Collecteur: 3.5" d'une colonne d'eau (GN) **Pression au Collecteur:** 1.5" d'une colonne d'eau (P)
Pression d'Alimentation Min.: 4.5" d'une colonne d'eau (GN) **Pression d'Alimentation Min.:** 1.5" d'une colonne d'eau (P)

Pression d'Alimentation Max.: 7" d'une colonne d'eau (GN) **Pression d'Alimentation Max.:** 19" d'une colonne d'eau (P)

Minimum clearance to combustible materials: Top, sides & back: per standards for framing and finishing materials. For non-combustible framing and finishing materials, see installation manual.
Départements minimaux des matériaux combustibles: Côtés, côtés et arrière: selon les règlements des départements pour les matériaux de finition. Pour les matériaux de finition non combustibles, voir le manuel de l'utilisateur.

Top X" Plancher X"
 Floor X" Côtés X"
 Sides X" Arrière X"
 Back X" Côtés et dessous du conduit d'évent X"
 Vent top X" Côtés et dessous du conduit d'évent X"
 Vent sides & bottom X" Profondeur d'encastré une face X"
 Recessed depth X" Tablette X" de l'ouverture de l'appareil

*** Maximum horizontal extension X" See installation manual for greater extensions, minimum vent lengths and maximum vent lengths. *** L'extension horizontale maximale: X" Voir le manuel d'installation pour des extensions plus grandes, les longueurs d'évacuation minimales et maximales.
 Electrical rating: 115V 60Hz. Less than 12 ampere. Spécifications électriques: 115V 60Hz. Moins de 12 ampère.

WOLF STEEL LTD. 24 Napoleon Road, Barrie, ON, L4M 0G8 Canada

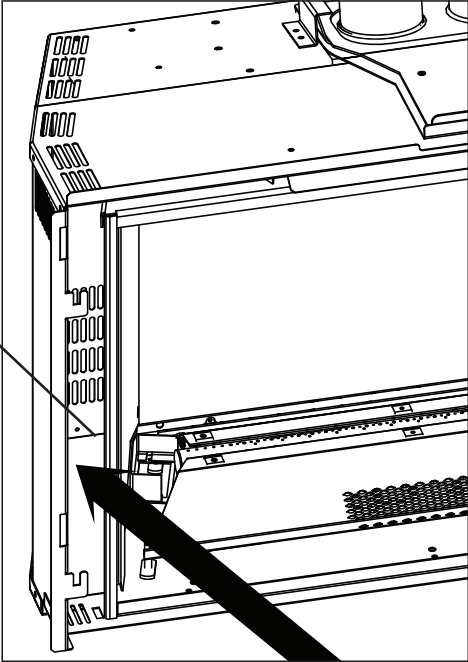

Left side view of appliance (GDIG3 illustrated)

note:
 The rating plate must remain with the appliance at all times. It must not be removed.

This illustration is for reference only. Refer to the rating plate on the appliance for accurate information.

1.3 operating and lighting instructions

OPERATING INSTRUCTIONS / INSTRUCTIONS D'OPÉRATION
FOR YOUR SAFETY READ BEFORE OPERATING / POUR VOTRE SÉCURITÉ LIRE AVANT DE FAIRE FONCTIONNER

WARNING: DO NOT TURN ON IF CHILDREN OR OTHER AT RISK INDIVIDUALS ARE NEAR THE APPLIANCE. IF YOU DO NOT FOLLOW THESE INSTRUCTIONS EXACTLY, A FIRE OR EXPLOSION MAY RESULT CAUSING PROPERTY DAMAGE, PERSONAL INJURY OR LOSS OF LIFE. INITIAL LIGHTING OF THE PILOT AND MAIN BURNERS MUST BE DONE WITH THE GLASS DOOR OFF. DO NOT CONNECT VALVE OR WALL SWITCH TO ELECTRICITY. SEE INSTALLATION INSTRUCTIONS.

ATTENTION: NE PAS ALLUMER SI DES ENFANTS OU D'AUTRES INDIVIDUS À RISQUE SONT À PROXIMITÉ DU FOYER. QUICONQUE NE RESPECTE PAS À LA LETTRE LES INSTRUCTIONS DANS LA PRÉSENTE NOTICE, RISQUE DE DÉCLANCHER UN INCENDIE OU UN EXPLOSION ENTRAÎNANT DES DOMMAGES, DES BLESSURES OU LA MORT. L'ALLUMAGE INITIAL DE LA VEILLEUSE ET DU BRÛLEUR PRINCIPAL DOIT SE FAIRE AVEC LA PORTE VITRÉE ENLEVÉE. NE RACCORDEZ PAS LA SOUPEPE OU L'INTERRUPTEUR MURAL À L'ÉLECTRICITÉ. CONSULTEZ LES INSTRUCTIONS D'INSTALLATION.

A. THIS APPLIANCE IS EQUIPPED WITH AN IGNITION DEVICE WHICH AUTOMATICALLY LIGHTS THE PILOT. DO NOT TRY TO LIGHT BY HAND.
B. BEFORE OPERATING, SMELL ALL AROUND THE APPLIANCE AREA FOR GAS AND NEXT TO THE FLOOR BECAUSE SOME GAS IS HEAVIER THAN AIR AND WILL SETTLE ON THE FLOOR.
WHAT TO DO IF YOU SMELL GAS:
• TURN OFF ALL GAS TO THE APPLIANCE.
• OPEN WINDOWS.
• DO NOT TRY TO LIGHT ANY APPLIANCE.
• DO NOT TOUCH ANY ELECTRICAL SWITCH; DO NOT USE ANY PHONE IN YOUR BUILDING.
• IMMEDIATELY CALL YOUR GAS SUPPLIER FROM A NEIGHBOUR'S PHONE. FOLLOW THE GAS SUPPLIER'S INSTRUCTIONS.
• IF YOU CANNOT REACH YOUR GAS SUPPLIER, CALL THE FIRE DEPARTMENT.
C. DO NOT TRY TO REPAIR ANY PART OF THIS ASSEMBLY. CALL A QUALIFIED SERVICE TECHNICIAN. FORCE OR ATTEMPTED REPAIR MAY RESULT IN A FIRE OR EXPLOSION.
D. DO NOT USE THIS APPLIANCE IF ANY PART HAS BEEN UNDER WATER. IMMEDIATELY CALL A QUALIFIED SERVICE TECHNICIAN TO INSPECT THE APPLIANCE AND REPLACE ANY PART OF THE CONTROL SYSTEM AND ANY GAS CONTROL WHICH HAS BEEN UNDER WATER.

A. CET APPAREIL EST MUNI D'UN DISPOSITIF D'ALLUMAGE QUI ALLUME AUTOMATIQUÉMENT LA VEILLEUSE. NE TENTEZ PAS D'ALLUMER LA VEILLEUSE MANUELLEMENT.
B. AVANT DE FAIRE FONCTIONNER, RENIFLEZ TOUT AUTOUR DE L'APPAREIL POUR DÉCELER UN ODEUR DE GAZ. RENIFLEZ PRÈS DU PLANCHER, CAR CERTAINS GAZ SONT PLUS LOURDS QUE L'AIR ET PEUVENT S'ACCUMULER AU NIVEAU DU SOL.
QUE FAIRE SI VOUS DÉTECTEZ UNE ODEUR DE GAZ:
• COUPEZ L'ALIMENTATION DE GAZ PRINCIPALE.
• OUVREZ LES FÉNÊTRES.
• NE PAS TENTER D'ALLUMER D'APPAREIL.
• NE TOUCHEZ À AUCUN INTERRUPTEUR; NE PAS VOUS SERVIR DES TÉLÉPHONES SE TROUVANT DANS LE BÂTIMENT.
• APPELEZ IMMÉDIATEMENT VOTRE FOURNISSEUR DE GAZ DEPUIS UN VOISIN. SUIVEZ LES INSTRUCTIONS DU FOURNISSEUR.
• SI VOUS NE POUVEZ REJOINDRE LE FOURNISSEUR APPELEZ LE SERVICE DES INCENDIES.
C. N'ESSAYEZ PAS DE RÉPARER AUCUNE PIÈCE DE CET ASSEMBLAGE. APPELEZ UN TECHNICIEN QUALIFIÉ. FORCER OU TENTER DE RÉPARER L'ASSEMBLAGE POURRAIT CAUSER UN FEU OU UNE EXPLOSION.
D. N'UTILISEZ PAS CET APPAREIL S'IL A ÉTÉ PLONGÉ DANS L'EAU, MÊME PARTIELLEMENT. FAITES INSPECTER L'APPAREIL PAR UN TECHNICIEN QUALIFIÉ ET REMPLACEZ TOUTE PARTIE DU SYSTÈME DE CONTRÔLE ET TOUTE COMMANDE QUI ONT ÉTÉ PLONGÉS DANS L'EAU.

W385-0460 / E

LIGHTING INSTRUCTIONS / INSTRUCTIONS D'ALLUMAGE

- STOP!** READ ALL INFORMATION OF OPERATING AND LIGHTING INSTRUCTIONS BEFORE PROCEEDING.
- TURN OFF ELECTRICAL POWER TO THE APPLIANCE.
- THIS APPLIANCE IS EQUIPPED WITH AN IGNITION DEVICE WHICH AUTOMATICALLY LIGHTS THE PILOT. DO NOT TRY TO LIGHT THE PILOT BY HAND.
- OPEN THE GLASS DOOR.
- TURN MANUAL SHUTOFF VALVE CLOCKWISE TO OFF.
- WAIT FIVE (5) MINUTES TO CLEAR OUT ANY GAS. IF YOU SMELL GAS, INCLUDING NEAR THE FLOOR, **STOP!** FOLLOW "B" OF THE OPERATING INSTRUCTIONS. IF YOU DON'T SMELL GAS, GO TO THE NEXT STEP.
- TURN MANUAL SHUTOFF VALVE COUNTER-CLOCKWISE TO ON.
- CLOSE THE GLASS DOOR.
- TURN ON ALL ELECTRICAL POWER TO THE APPLIANCE.
- TURN ON MAIN BURNER.

TO TURN OFF GAS / INSTRUCTIONS POUR COUPER LE GAZ

- COUPEZ L'ALIMENTATION ÉLECTRIQUE AU FOYER SI UN TRAVAIL D'ENTRETIEN DOIT SE FAIRE.
- TOURNEZ LA SOUPEPE D'ARRÊT MANUELLE VERS LA DROITE À « OFF ». NE FORCEZ PAS.

W385-0460 / E

1.4 shut-off valve

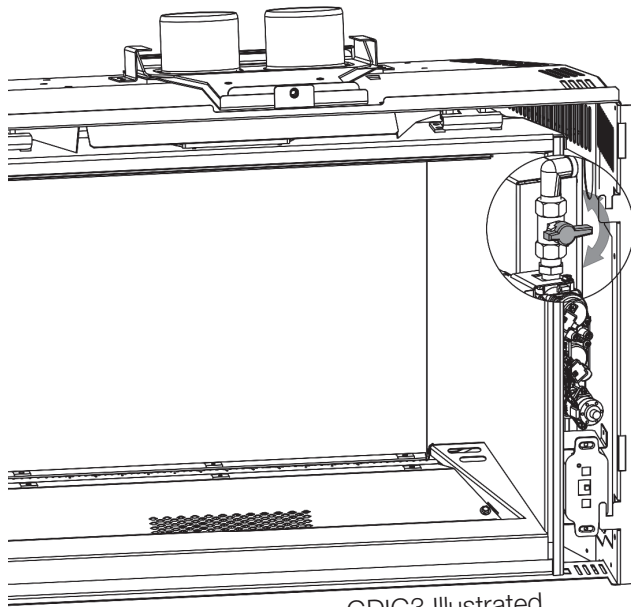

The shut-off valve is in the OFF position when the handle is horizontal (see illustration).

The shut-off valve is in the ON position when the handle is vertical.

note:

A tool has been provided to shut off the gas.

general information

1.5 dimensions

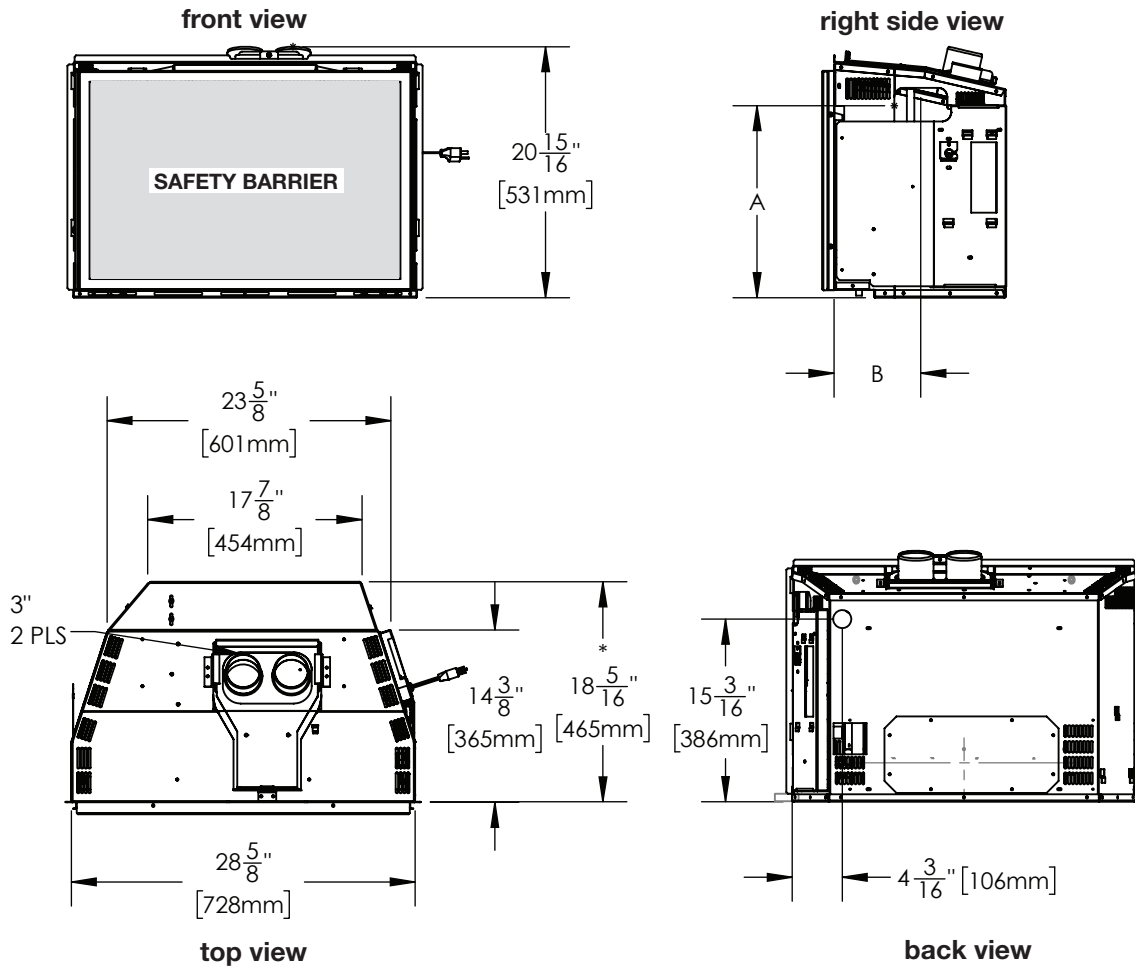

Ref.	GDI3	GDI3E	GDIG3	GDIX3
A	13 7/16" [341mm]		13 13/16" [376mm]	
B	7 1/2" [190mm]		6 7/8" [175mm]	

* Dimension with optional blower kit installed.

1.6 minimum clearance to combustibles

This appliance must be recessed into a vented non-combustible wood-burning appliance (prefabricated or masonry) only. The minimum appliance opening size in which the appliance is to be installed is:

HEIGHT 21 1/2" (54.6cm) WIDTH 29" (73.7cm) DEPTH * 14 3/8" (36.6cm)

The minimum allowable chimney flue size is 6" (152mm) round.

***Add 4" (102mm) for optional blower.**

The minimum distance from the bottom of a combustible mantel projecting 3" (76mm) maximum from the wall to the top of the appliance is 12" (30.4cm) (see "minimum mantel clearances" section).

note:

A non-combustible hearth must protrude a minimum of 12" (30.5cm) from the appliance.

A combustible hearth may be used if the appliance is raised 4" (102mm) above the hearth or if a Wolf Steel raiser box is installed.

! WARNING

- Risk of fire! Maintain specified air space clearances to vent pipe and appliance.

Clean out ashes from the inside of the wood-burning appliance. Make sure that the chimney and wood-burning appliance are in a clean and sound condition and constructed of non-combustible materials. If necessary have any repair work done by a qualified person before installing the insert. Remove the existing appliance damper or lock into an open position.

Using screws, attach the appliance warning tag to the inside of the firebox of the appliance into which the insert is being installed.

The sheet-metal parts of the appliance, in which the gas appliance insert is to be installed, must not be cut.

If the wood-burning factory-built appliance has no gas access hole(s) provided, an access hole of 1½ inch (38.1mm) or less may be drilled through the lower sides or bottom of the appliance in a proper workman like manner. This access hole must be plugged with non-combustible insulation after the gas supply line has been installed.

Ensure that existing chimney cleanouts fit properly.

The refractory, glass doors, screen rails, screen mesh and log grates may be removed from the existing appliance before installing the gas appliance insert.

Smoke shelves, shields and baffles may be removed if attached by mechanical fasteners.

The ventilation openings in the existing appliance may be obstructed by the backer plates, aluminium trim etc. but these parts are not to be applied so as to have an airtight seal.

WARNING: THIS FIREPLACE HAS BEEN CONVERTED FOR USE WITH A GAS FIREPLACE INSERT ONLY AND CANNOT BE USED FOR BURNING WOOD OR SOLID FUELS UNLESS ALL ORIGINAL PARTS HAVE BEEN REPLACED AND THE FIREPLACE IS RE-APPROVED BY THE AUTHORITY HAVING JURISDICTION.

ATTENTION: CE FOYER A ETE CONVERTI AFIN D'ETRE UTILISE SEULEMENT
 ○ COMME FOYER ENCASTRE AU GAZ ET NE PEUT ETRE UTILISE POUR BRULER DU BOIS OU
 TOUT AUTRE COMBUSTIBLE SOLIDE, SANS QUE TOUTES LES PIECES ORIGINALES AIENT
 ETE REMPLACEES ET QUE LE FOYER SOIT APPROUVE DE NOUVEAU PAR LES AUTORITES
 AYANT JURISDICTION.

ADVERTENCIA: ESTA CHIMENEA SE REMODELÓ PARA USARSE SOLO CON UNA
 INSERCIÓN DE CHIMENEA A GAS Y NO PUEDE USARSE PARA QUEMAR MADERA NI COMBUSTIBLES
 SÓLIDOS, A MENOS QUE SE HAYAN REEMPLAZADO TODAS LAS PIEZAS ORIGINALES, Y LA AUTORIDAD
 JURISDICCIONAL LA HAYA VUELTO A APROBAR. W385-0199_B

2.1 levelling the appliance

Have an authorized dealer install the appliance. If you install the appliance yourself, have your dealer review your installation plans and/or installation. Draw out a detailed plan of the installation including dimensions and verify the dimensions with the requirements listed in this manual.

You may wish to adjust the appliance position slightly to ensure the vent does not intersect with a framing member. Appliance must be positioned so that no combustibles are within, or can swing within (e.g. drapes, doors), 48" (121.9cm) of the front of the appliance.

Inserts only: This appliance is equipped with 4 levelling legs. Level the appliance before installing into the final position, as levelling will eliminate rocking or excessive noise when the fan is in operation. Once the appliance is level, move it partially into place to allow for all connections to be made. It is not practical to level the appliance once it has been installed. Determine the required depth prior to installing the appliance and adjust the levelling screws accordingly.

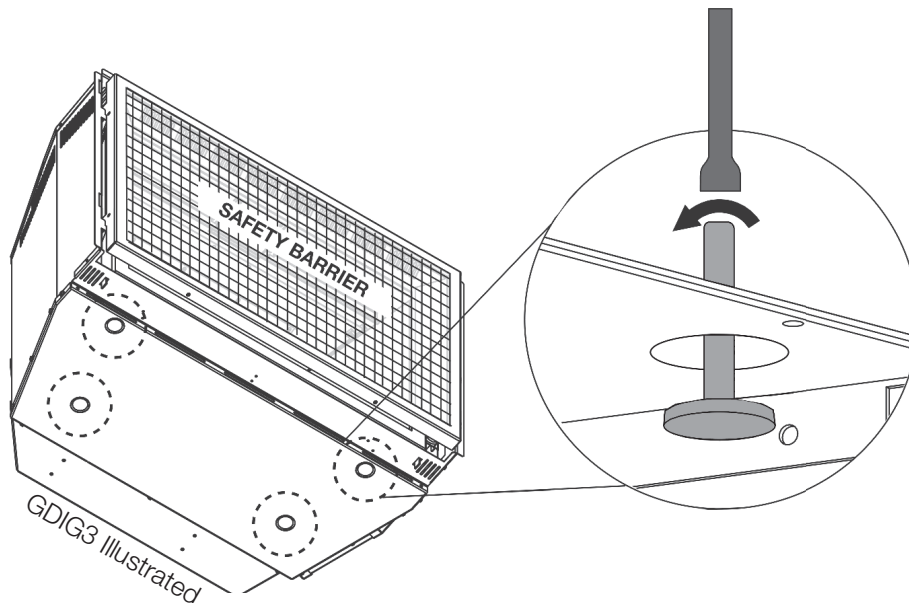

installation planning

2.2 chimney connection

Chimney installation must conform to both national and local code requirements. The chimney must be lined with one 3" (76mm) diameter liner for intake and one 3" (76mm) diameter liner for exhaust. The minimum and maximum vent lengths are 10' (3m) and 45' (14m) respectively. Recommended kits come in 4 lengths:

2x 3" (51-76mm) DOUBLE PLY ALUMINUM LINER-INLET AND EXHAUST:

GDI-320KT	VENT KIT 20FT (6M)
GDI-325KT	VENT KIT 25 FT (7M)
GDI-335KT	VENT KIT 35 FT (11M)
GDI-345KT	VENT KIT 45 FT (14M)

While the liners must be continuous from the appliance to the chimney cap, to achieve the needed length, they may be coupled, using an approved coupler.

We recommend that exhaust vents that pass through unheated spaces, such as tall exterior chimneys, be wrapped in a protective sleeve to minimize condensation and reverse flow symptoms. See "troubleshooting" section for details.

This appliance is approved for use with a 3" (76mm) exhaust and air intake.

- A. OUTSIDE:** Slip the one end of a liner a minimum of 2" (51mm) over the sleeve of the air terminal. Secure using 3 screws. Then seal the joint and screw heads with high temperature sealant. Repeat with the other liner.

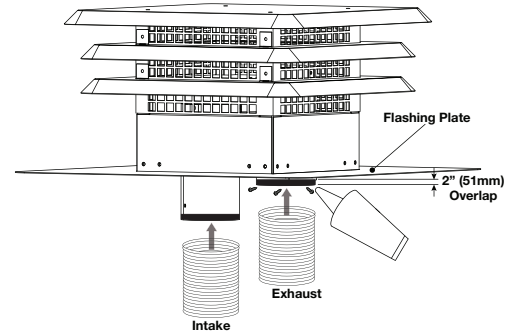

note:

We recommend that the other end of the exhaust liner be marked to eliminate the exhaust liner being connected to the intake collar at the appliance.

- B.** Gently stretch the liners to the required lengths and insert into the chimney. Trim and fit the flashing plate to suit the chimney termination. Place the air terminal onto the top of the chimney. Make weather tight by sealing with caulking (not supplied). Fasten to the chimney with screws and plugs (not supplied).

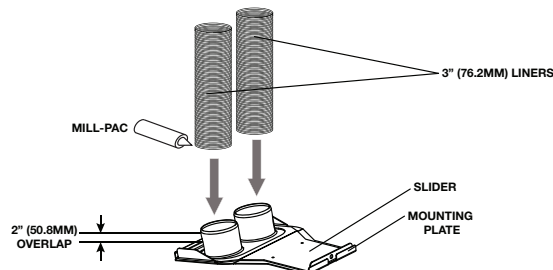

- C. INSIDE:** Remove the securing screw from the front of the vent mounting assembly. Slide the vent mount assembly from the track. Route the flex liners through the slider. Attach and secure the liners to the vent mounting plate, ensuring that the marked exhaust liner is attached to the exhaust collar.

note:

Prior to sliding the appliance into place, high temperature-rated insulation should be packed around the liner in the damper area to prevent air flow from entering the chimney from the home. Not doing so will have a negative impact on the efficiency of the appliance.

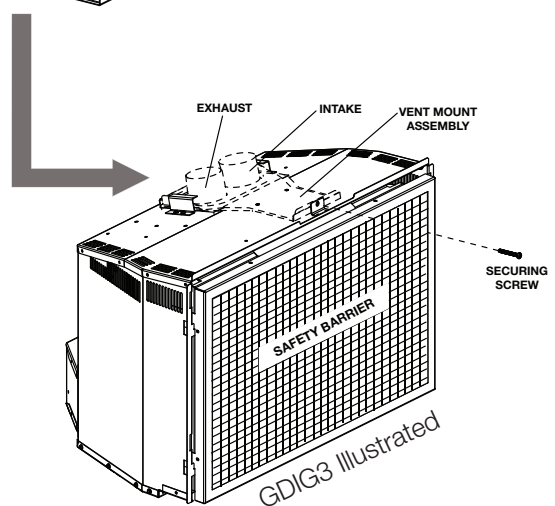

- D.** The appliance may now be pushed into the opening and the mounting plate assembly slid back into the track, and the securing screw started. Once the appliance is in its final position, tighten the securing screw until the slider makes contact with the front stop.

We recommend the following method of sealing off the damper area around the liner:
 Measure the throat of the appliance and mark this shape on a piece of 24 gauge sheet metal (flue cover). Cut a 6 3/4" (171mm) hole to lie directly below the appliance flue opening. Allow 2" of material for a flange on all sides and cut to these measurements. Bend down the flanges. If you have never done this before, it might be a good idea to make a cardboard pattern and test it first. Fasten this flue cover in position as high as possible with two masonry screws per side through the flanges into the appliance.

2.3 gas installation

! WARNING

- Risk of fire, explosion, or asphyxiation. Ensure there are no ignition sources such as sparks or open flames.
- Support gas control when attaching gas supply pipe to prevent damaging gas line.
- Always light the pilot whether for the first time or if the gas supply has run out with the glass door opened or removed. Purging of the gas supply line should be performed by a qualified service technician. Ensure that a continuous gas flow is at the burner before closing the door. Ensure adequate ventilation. For gas and electrical locations, see "dimensions" section.
- All gas connections must be contained within the appliance when complete **(gas fireplaces only)**.
- High pressure will damage valve. Disconnect gas supply piping before testing gas line at test pressures above 1/2 PSIG.
- Valve settings have been factory set, do not change.

Installation and servicing to be done by a qualified installer.

- Move the appliance into position and secure.
- This appliance is designed to accept a 1/2" (13mm) gas supply. The appliance is also equipped with a manual shut-off valve to turn off the gas supply to the appliance.
- Connect the gas supply in accordance to local codes. In the absence of local codes, install to the current CAN/CSA-B149.1 Installation Code in Canada or to the current National Fuel Gas Code, ANSI Z223.1 / NFPA 54 in the United States.
- When flexing any gas line, support the gas valve so that the lines are not bent or kinked.
- The gas line flex-connector should be installed to provide sufficient movement for shifting the burner assembly on its side to aid with servicing components.
- Check for gas leaks by brushing on a soap and water solution. **Do not use open flame.**

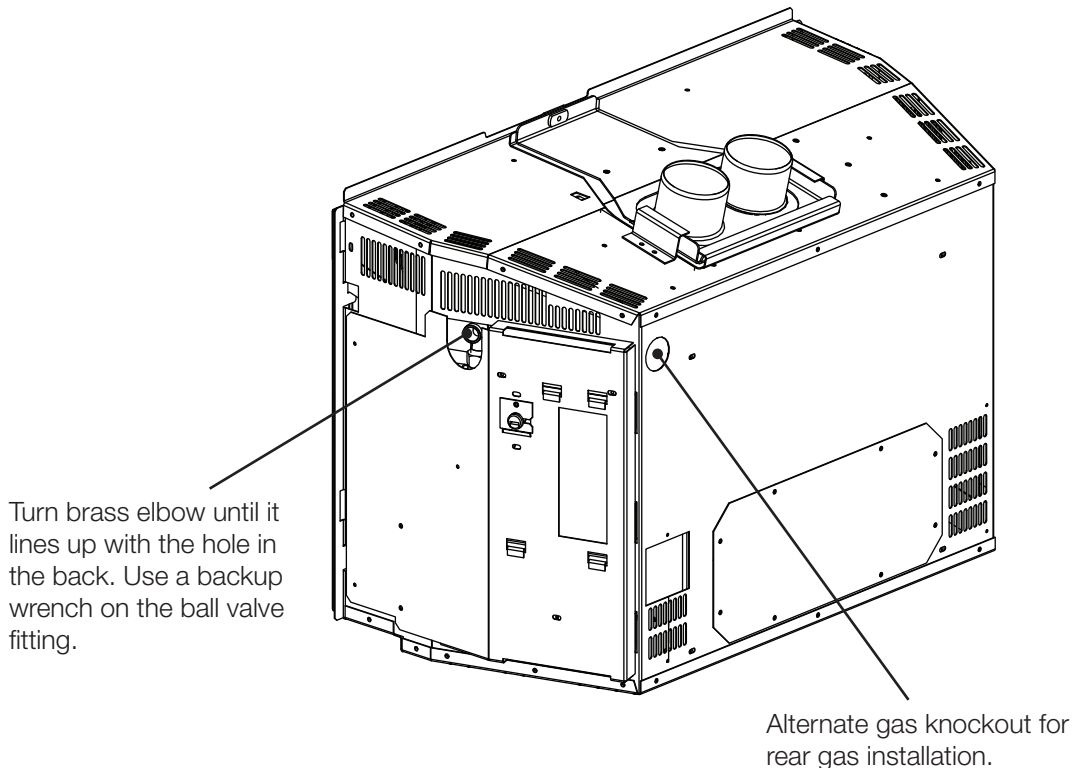

3.0 finishing

! WARNING

- Risk of fire!
- Never obstruct the front opening of the appliance.
- The front of the appliance must be finished with any non-combustible materials such as brick, marble, granite, etc., provided that these materials do not go below the specified dimension, as illustrated.
- Do not strike, slam, or scratch. Do not operate appliance with glass removed, cracked, or scratched.
- Facing and/or finishing material must never overhang into the appliance opening.
- The glass door assembly is a safety device designed to pivot forward when relieving excess pressure that might occur. Finishing or other materials must not be located in the opening surrounding the door as this will interfere with the doors ability to relieve pressure.
- If applicable, drywall dust will penetrate into the blower bearings, causing irreparable damage. Care must be taken to prevent drywall dust from coming into contact with the blower or its compartment. Any damage resulting from this condition is not covered by the warranty policy.

3.1 minimum combustible mantel clearances

! WARNING

- Risk of fire. Maintain all specified air space clearances to combustibles. Failure to comply with these instructions may cause a fire or cause the appliance to overheat. Ensure all clearances (i.e. back, side, top, vent, mantel, front, etc.) are clearly maintained.
- When using paint or lacquer to finish the mantel, the paint or lacquer must be heat resistant to prevent discolouration.

Combustible mantel clearance can vary according to the mantel depth. Use the graph to help evaluate the clearance needed. These same requirements apply to any combustibles protruding on either side of the appliance.

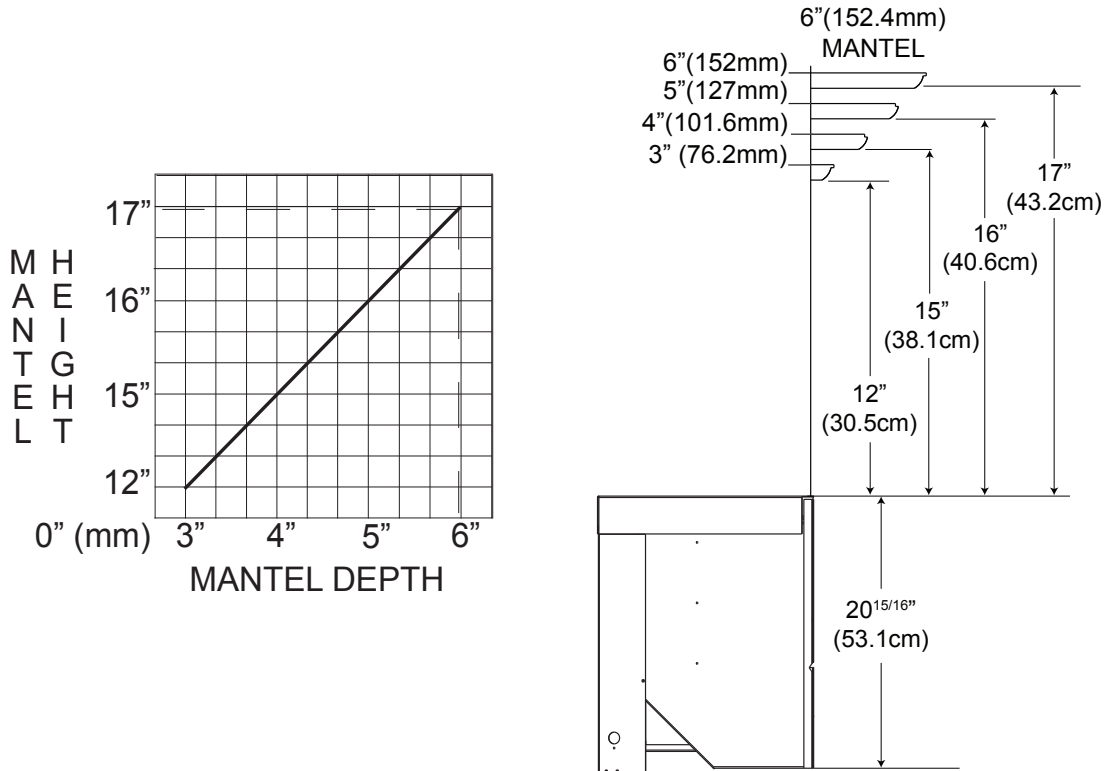

3.2 safety barrier & door removal / installation

! WARNING

- Glass may be hot. Do not touch glass until cooled.
- If equipped with door latches that are part of a safety system, they must be properly engaged. Do not operate the appliance with latches disengaged.
- Facing and/or finishing materials must not interfere with air flow through air openings, louvre openings, operation of louvres, or doors/access for service. Observe all clearances when applying combustible materials.
- Before door is removed, turn the appliance off and wait until appliance is cool to the touch. Doors are heavy and fragile so handle with care.

A barrier designed to reduce the risk of burns from the hot viewing glass is provided with the appliance and must be installed.

1. Before the glass door can be removed, the safety barrier must be removed. Lift the safety barrier from the 4 tabs, tilt the top forward, and remove from the appliance (**Fig. 3-1 and 3-2**).

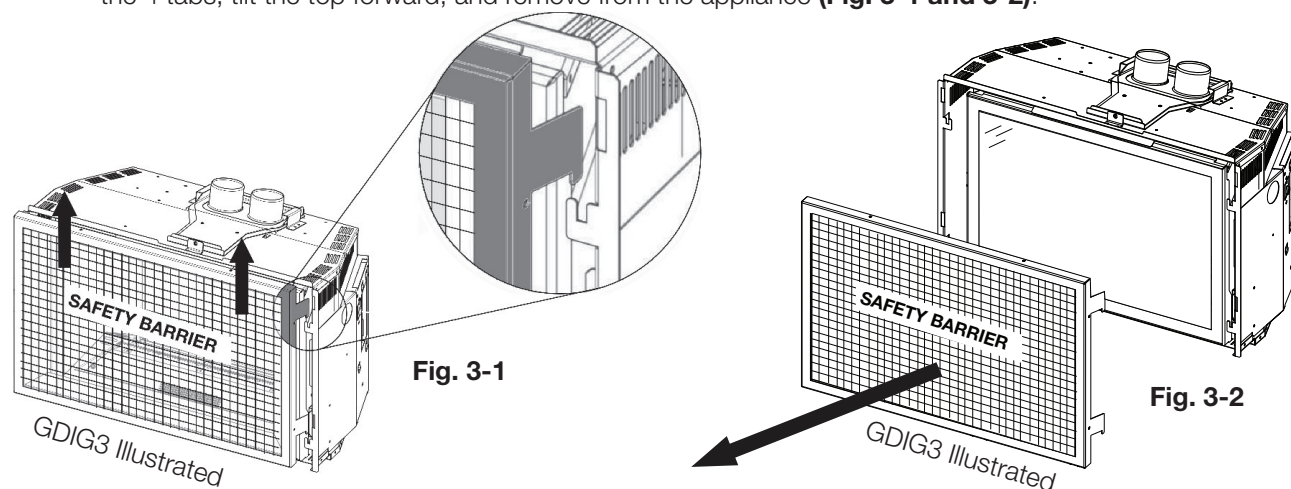

note:

If applicable, the optional front must be removed to allow the door to be opened or closed.

2. Release the top left and right door latches, located at the top of the door (**Fig. 3-3**). Tilt forward and lift from slots.

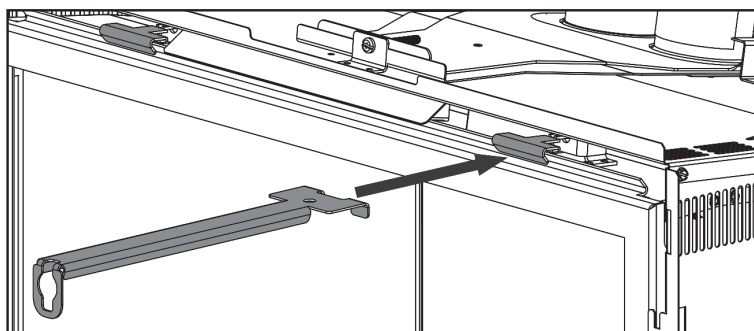

3. Reverse these steps to re-install the safety barrier and glass door. Ensure safety barrier is installed correctly.

finishing

3.3 log placement

3.3.1 log placement for GDI3 / GDI3E

! WARNING

- Failure to position the logs in accordance with these diagrams or failure to use only logs specifically approved with this appliance may result in property damage or personal injury.
- Logs must be placed in their exact location in the appliance. Do not modify the proper log positions, since appliance may not function properly and delayed ignition may occur.
- The logs are fragile and should be handled with care.

PHAZER™ log and glowing embers, exclusive to Wolf Steel Ltd., provide a unique and realistic glowing effect that is different in every installation. Take the time to carefully position the glowing embers for a maximum glowing effect. Log colours may vary. During the initial use of the appliance, the colours will become more uniform as colour pigments burn in during the heat-activated curing process.

note:

Log numbers are located on the bottom or back of the logs.

Log Number	Part Number	Description
1	W135-0778	Rear log
2	W135-0779	Right log
3	W135-0780	Left log
4	W135-0782	Left crossover log
5	W135-0781	Right crossover log
6	W135-0783	Left charcoal log
7	W135-0784	Center charcoal log
8	W135-0785	Right charcoal

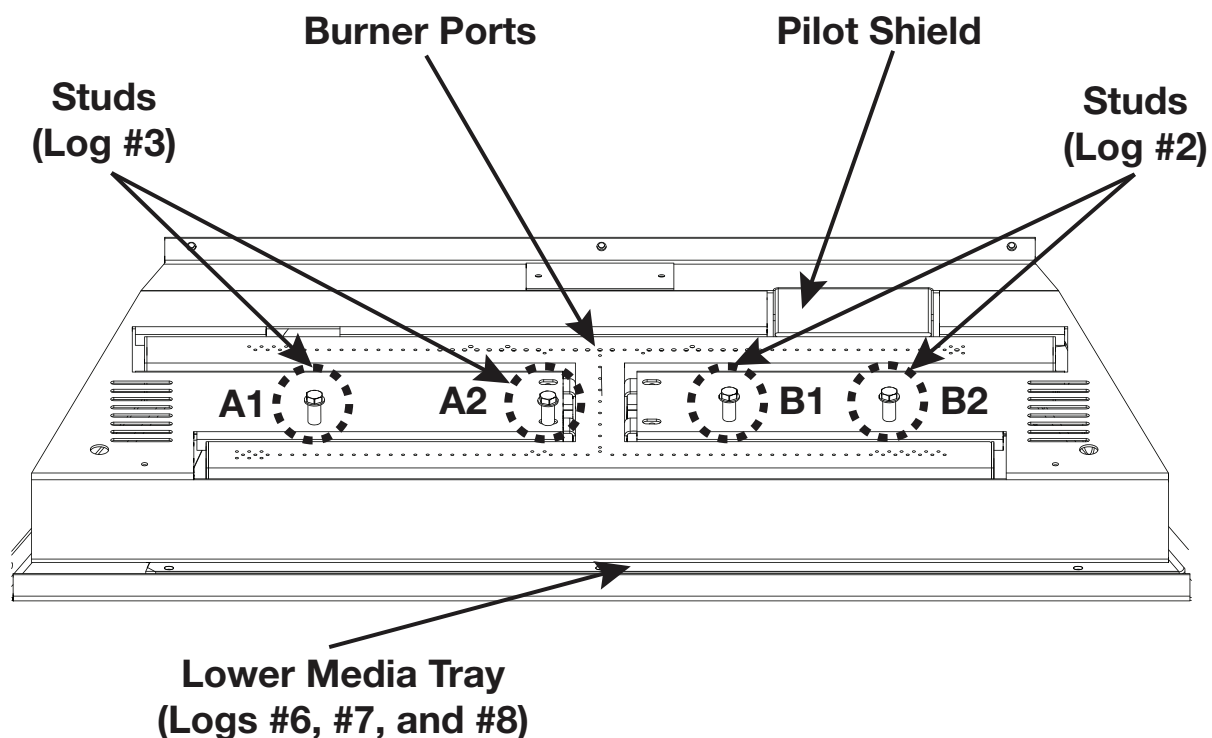

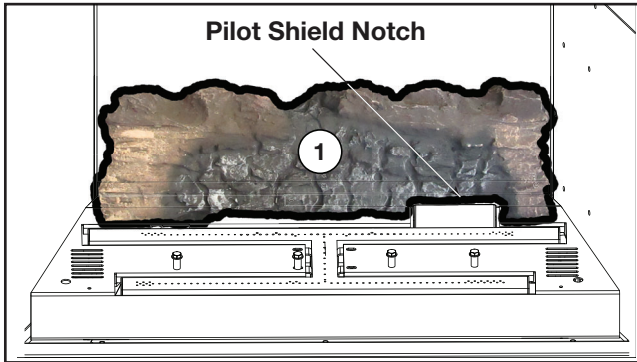

1. Place log #1 snug against the back wall, ensuring the notch fits around the pilot shield.

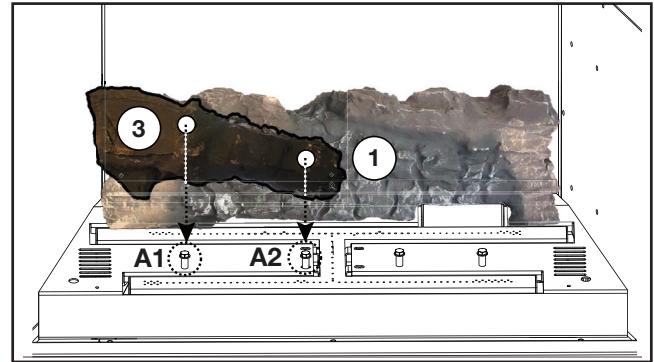

2. Place the two holes in log #3 on A1 and A2. Do not cover any burner ports.

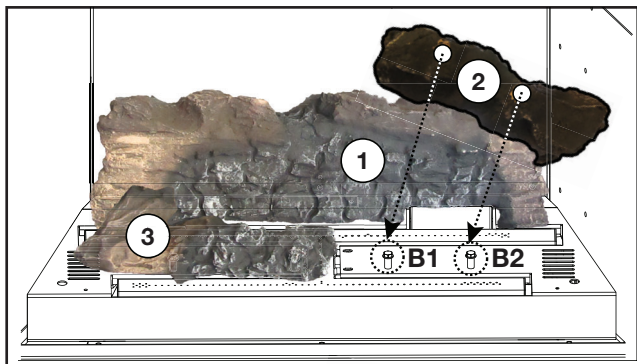

3. Place the two holes in log #2 on B1 and B2. Do not cover any burner ports.

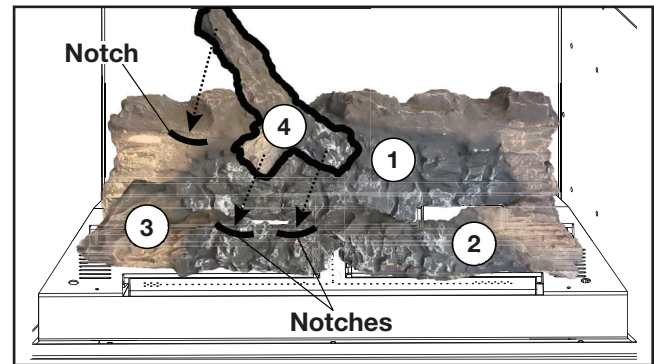

4. Place log #4 on the left-side notch of log #1 and the two notches of log #3.

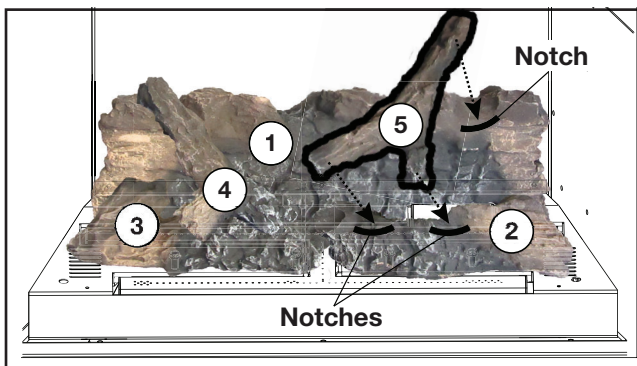

5. Place log #5 on the right-side notch of log #1 and the two notches of log #2.

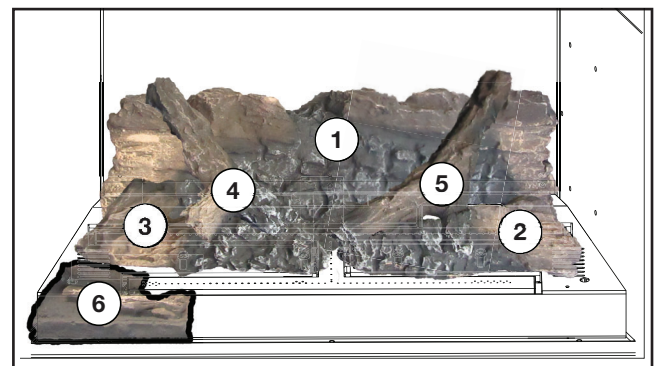

6. Place log #6 along the left side of the lower media tray.

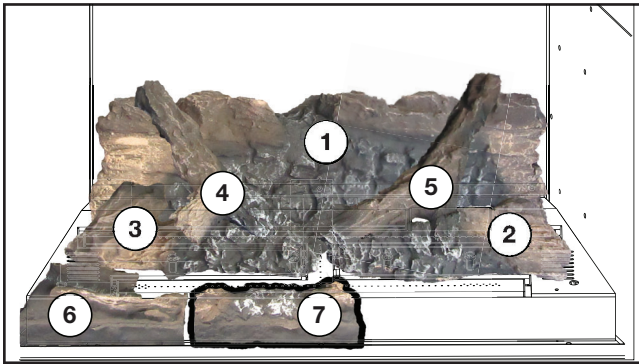

7. Place log #7 along the centre of the lower media tray.

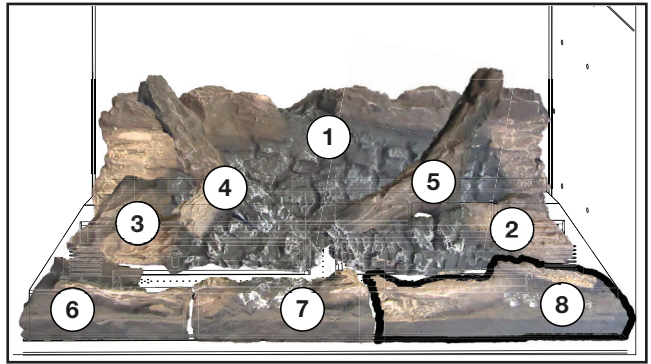

8. Place log #8 along the right side of the lower media tray.

note:
Logs #6, #7, and #8 must be flush with the edge of the firebox.

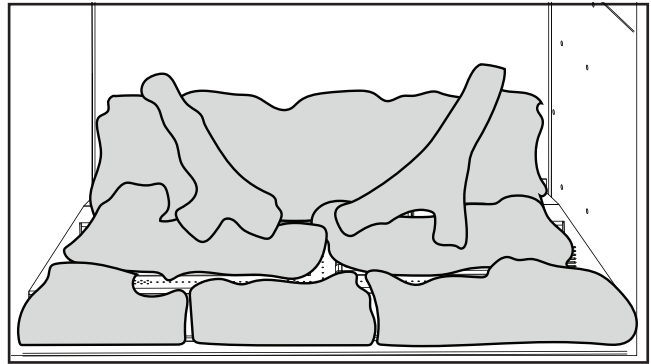
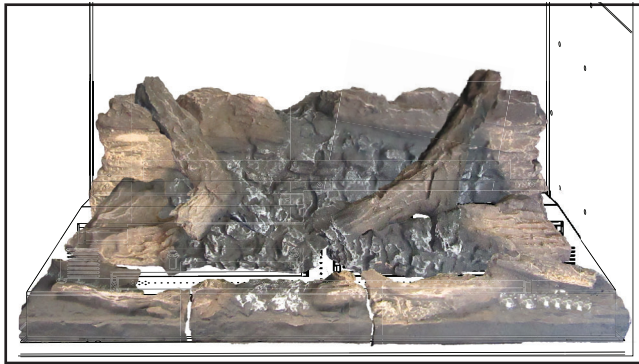

3.3.2 log placement for GDIX3

! WARNING

- Failure to position the logs in accordance with these diagrams or failure to use only logs specifically approved with this appliance may result in property damage or personal injury.
- Logs must be placed in their exact location in the appliance. Do not modify the proper log positions, since appliance may not function properly and delayed ignition may occur.
- The logs are fragile and should be handled with care.

PHAZER™ log and glowing embers, exclusive to Wolf Steel Ltd., provide a unique and realistic glowing effect that is different in every installation. Take the time to carefully position the glowing embers for a maximum glowing effect. Log colours may vary. During the initial use of the appliance, the colours will become more uniform as colour pigments burn in during the heat-activated curing process.

note:

Log numbers are located on the bottom or back of the logs.

Log Number	Part Number	Description
1	W135-0778	Rear log
2	W135-0779	Right log
3	W135-0880	Left log
4	W135-0782	Left crossover log
5	W135-0781	Right crossover log
6	W135-0786	Charcoal strip log
7		

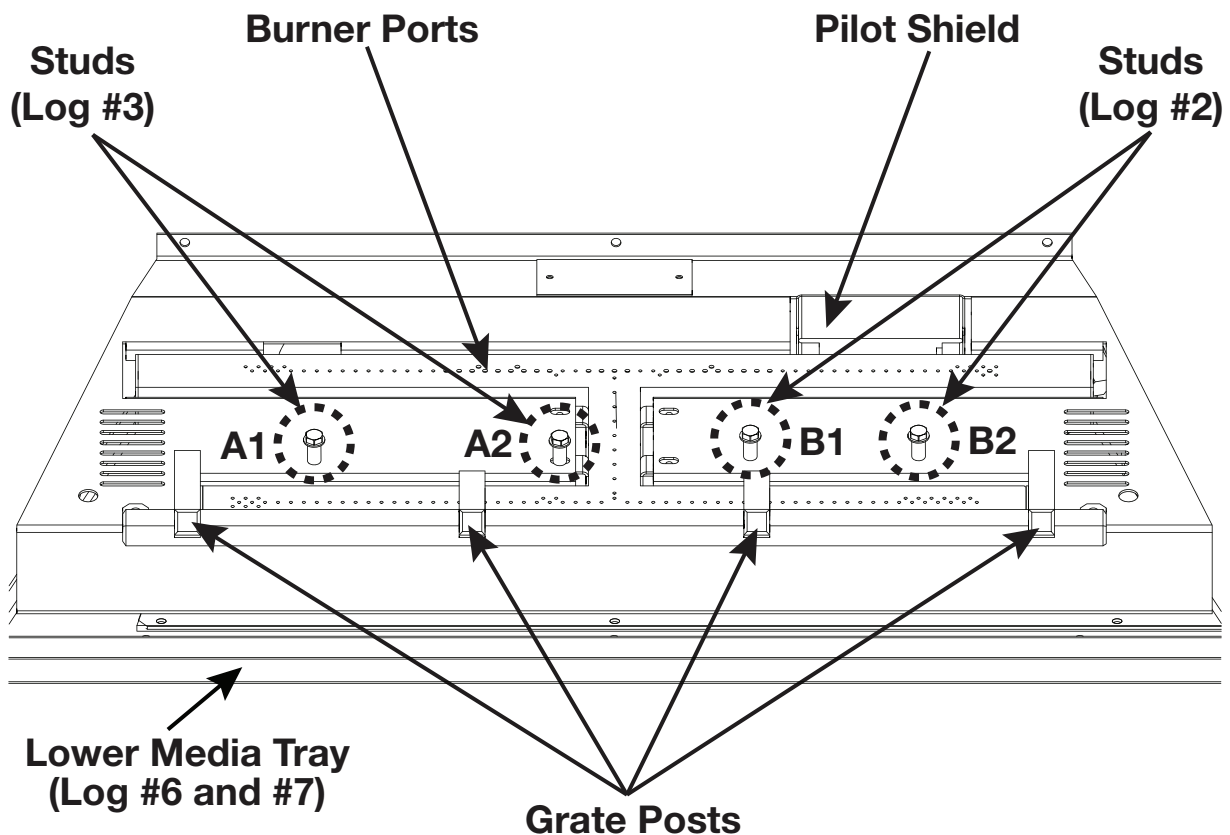

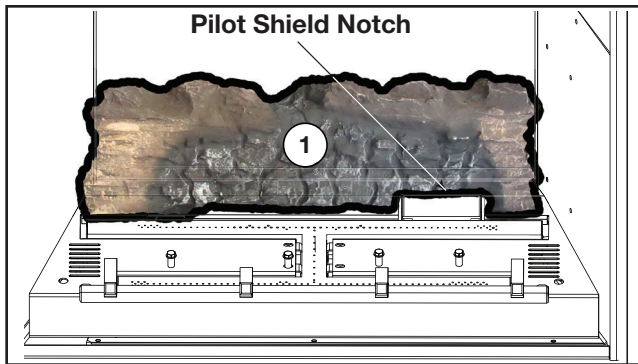

1. Place log #1 snug against the back wall, ensuring the notch fits around the pilot shield.

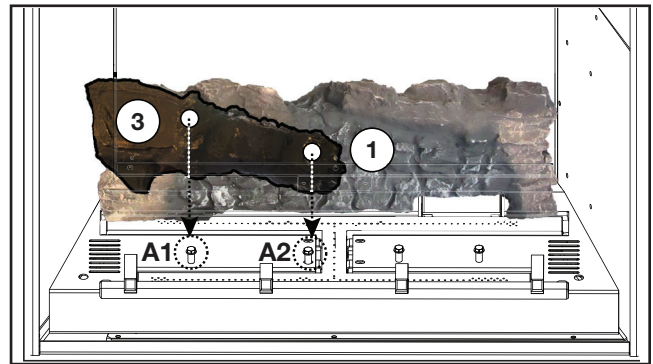

2. Place the two holes in log #3 on A1 and A2. Do not cover any burner ports.

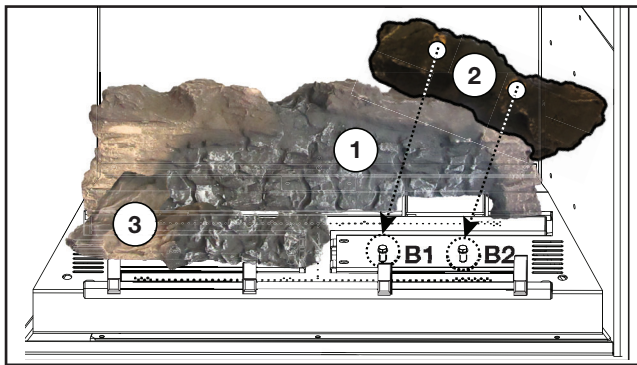

3. Place the two holes in log #2 on B1 and B2. Do not cover any burner ports.

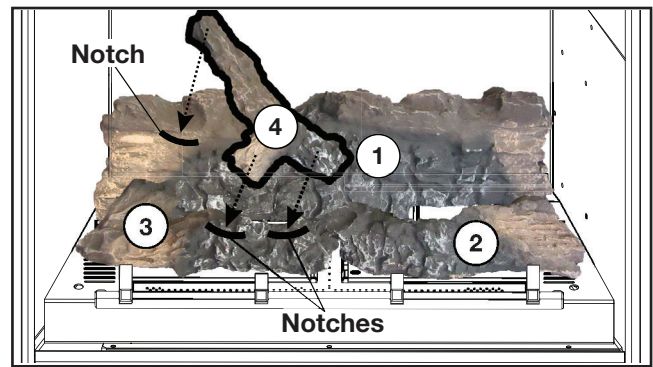

4. Place log #4 on the left-side notch of log #1 and the two notches of log #3.

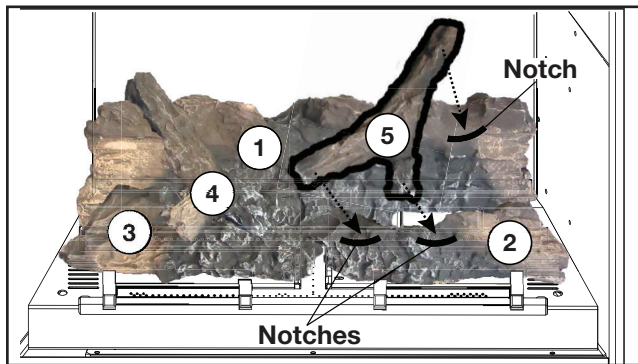

5. Place log #5 on the right-side notch of log #1 and the two notches of log #2.

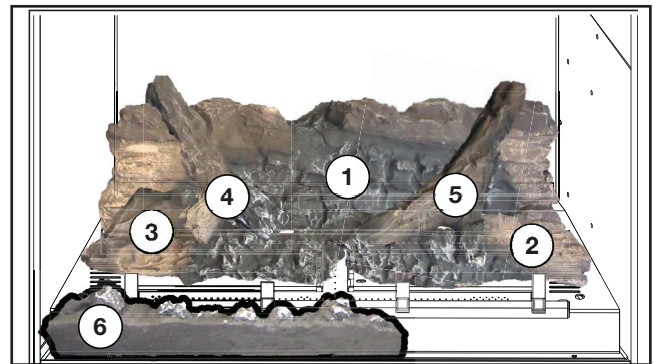

6. Place log #6 along the left side of the lower media tray.

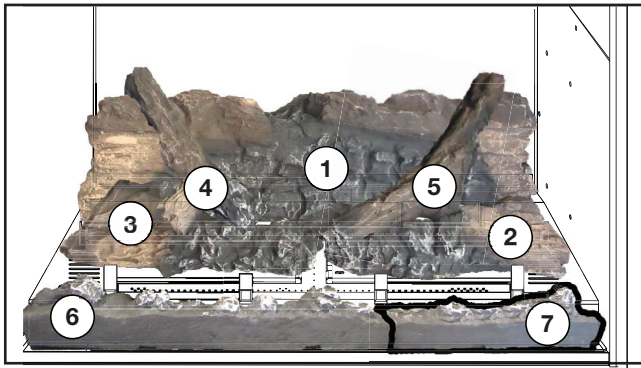

7. Place log #7 along the right side of the lower media tray.

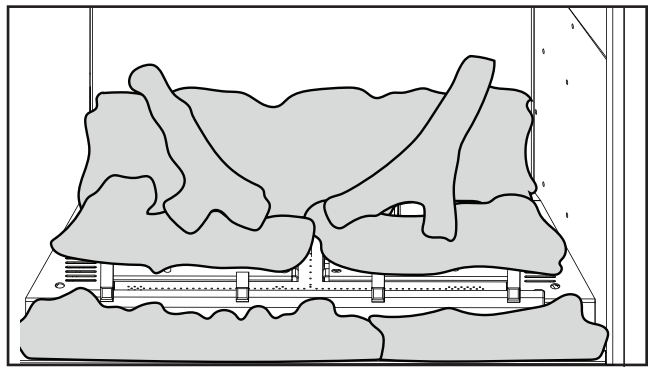
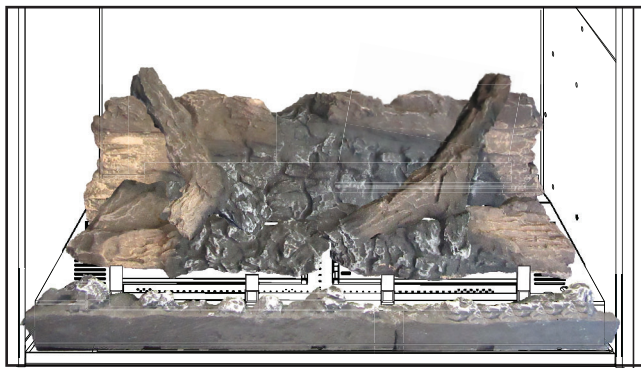

3.4 media installation

! WARNING

- Clean the glass media prior to installation. Before applying the cleaned glass, ensure that it is dry.
- Do not change or substitute the glass media material provided with this appliance. If replacing, use only the replacement glass media available from your local authorized dealer / distributor.
- Glass media over the burner must not be more than one layer high. More than one layer over the burner will cause flame lifting and sooting problems.
- Do not place any media (glass or vermiculite) in or around the pilot opening. This will interfere with the pilot operation.

Evenly spread the glass media onto the media tray, covering the burner tube and tray.

note:

There must only be a single layer of glass media over the burner tube.

Ensure no glass media falls into the pilot opening. If this happens, insert a clean bag into your vacuum cleaner and vacuum out the glass media. Replacement glass can be purchased from your local authorized dealer / distributor. Glass media over the burner ports may cause a "puffing" sound. To eliminate this sound, simply push the media away from the burner ports.

note:

The distribution of glass media over the burner ports will influence the flame height. When the flames impinge on the glass, the glass may discolour slightly and the edges may soften.

note:

Do not use more media than what was supplied with the appliance.

Cleaning Glass Media

Glass media may have a fine oil residue that needs to be cleaned prior to installation. Clean the glass with mild dish soap, drain, rinse thoroughly, and dry before placing over the burner.

3.5 logo placement

Remove the backing of the logo supplied and place, as illustrated.

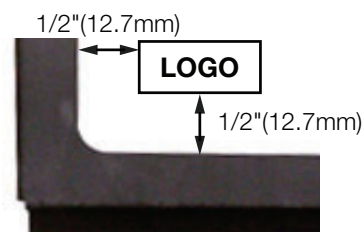

3.6 glowing embers

! WARNING

- Completely blocking the burner ports can cause an incorrect flame pattern, carbon deposits and delayed ignition.

Tear the embers into pieces and loosely layer above the burner ports covering the burner area. Care should be taken to shred the embers into thin, small irregular pieces as only the exposed edges of the fibre hairs will glow.

The ember material will only glow when exposed to direct flame; however, care should be taken to not block off the burner ports.

Blocked burner ports can cause an incorrect flame pattern, carbon deposits and delayed ignition. **PHAZER™** logs glow when exposed to direct flame. Use only certified "glowing embers" and **PHAZER™** logs available from your local authorized dealer / distributor.

3.7 charcoal embers

! WARNING

- Do not block or close off the burner ports. Blocked ports can cause an incorrect flame pattern, carbon deposits and delayed ignition.
- When supplied, charcoal embers, charcoal lumps and vermiculite are not to be placed on the burner.

Randomly place the charcoal embers along the front and sides of the log support in a realistic manner.

Fine dust found in the bottom of the bag should not be used.

note:
Charcoal embers are not to be placed on the burner.

3.8 battery installation (GDIG3 / GDIX3)

4 AA batteries must be installed into the receiver before the appliance can operate by battery backup. The receiver is located in the bottom right corner of the appliance (**Fig. 3-4**).

1. Remove the battery cover plate by pushing the two tabs that hold the cover in place.
2. Remove the 4 AA batteries in the battery holder and replace with new ones.

note:
Note the polarity of the batteries and insert as indicated on the cover (+/-).

3. Reinstall the cover plate.

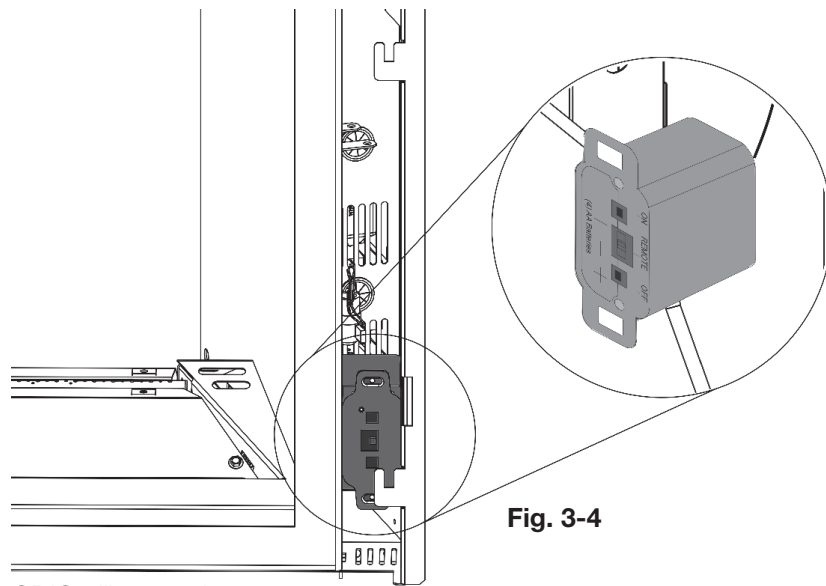

note:
Ensure the 3 position slider switch is in the "REMOTE" position (middle position).

GDIG3 Illustrated

3.9 battery installation (GDI3E)

1. Remove battery holder by sliding it forward from the bracket (**Fig. 3-5**).
2. Install 4 batteries.
3. Reinstall battery holder.

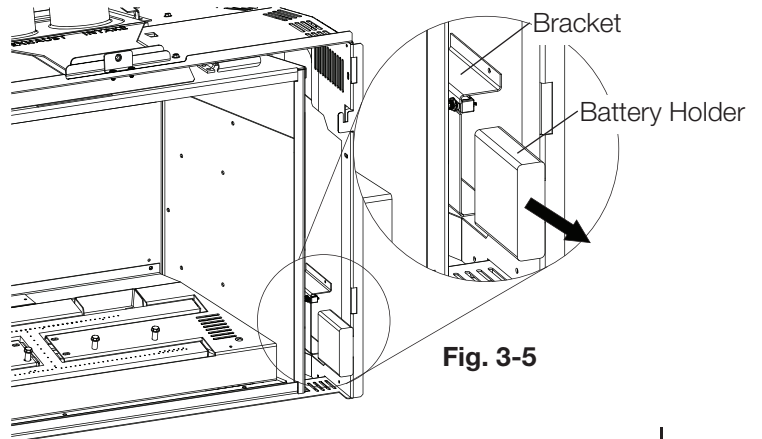

3.10 receiver removal

1. Remove the right access panel from the side of the appliance.
2. Remove the front 2 screws from the inside edge (**Fig. 3-6**) and swing the control door open.

note:

If your opening is too small, you may need to pull the appliance out slightly.

3. Remove the 2 screws holding the receiver in place.
4. Remove the receiver and replace.

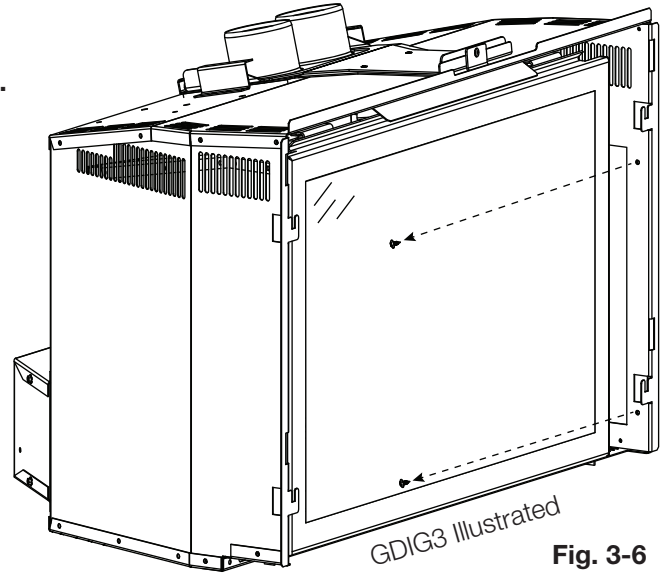

Fig. 3-6

3.11 bracket installation for optional F45/60 receiver (GDI3)

1. Remove the safety barrier and glass door (see "safety barrier & door removal / installation" section).
2. Remove the 1 screw holding the bracket in place (**Fig. 3-7**). Lift the bracket up and out of the slots, lifting it through the opening between the firebox and the appliance's outer shell (**Fig. 3-8**).

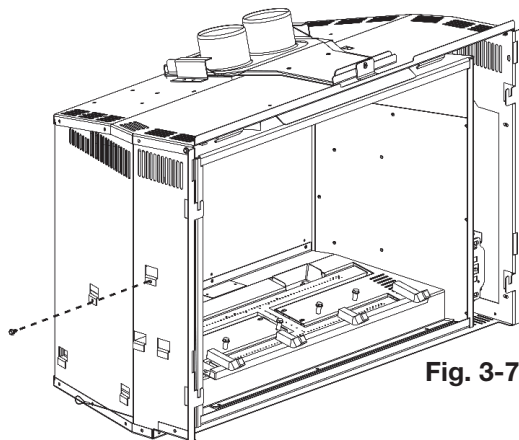

Fig. 3-7

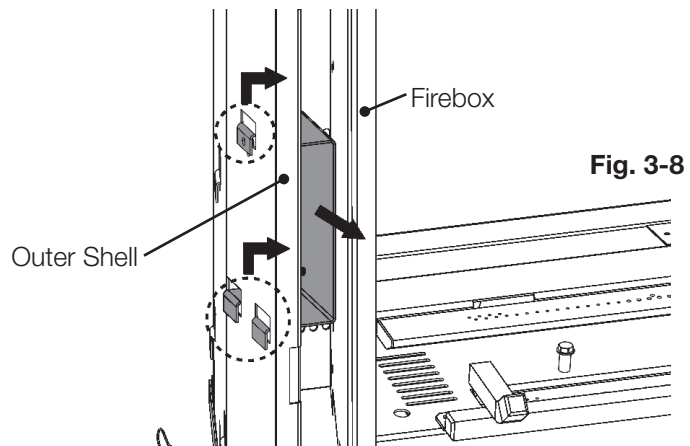

Fig. 3-8

3. Insert the optional receiver (F45 or F60) into the bracket. Secure the receiver using 2 screws (supplied).
4. Place the bracket and receiver back through the opening between the firebox and the appliance's outer shell. Slide the bracket and receiver into and down the slots (**Fig. 3-8 in reverse**).
5. Resecure the 1 screw to hold the bracket and receiver in place (**Fig. 3-7**).

4.1 wiring diagram (GDIG3 / GDIX3)

! WARNING

- Do not wire 110 volts to the valve or wall switch.

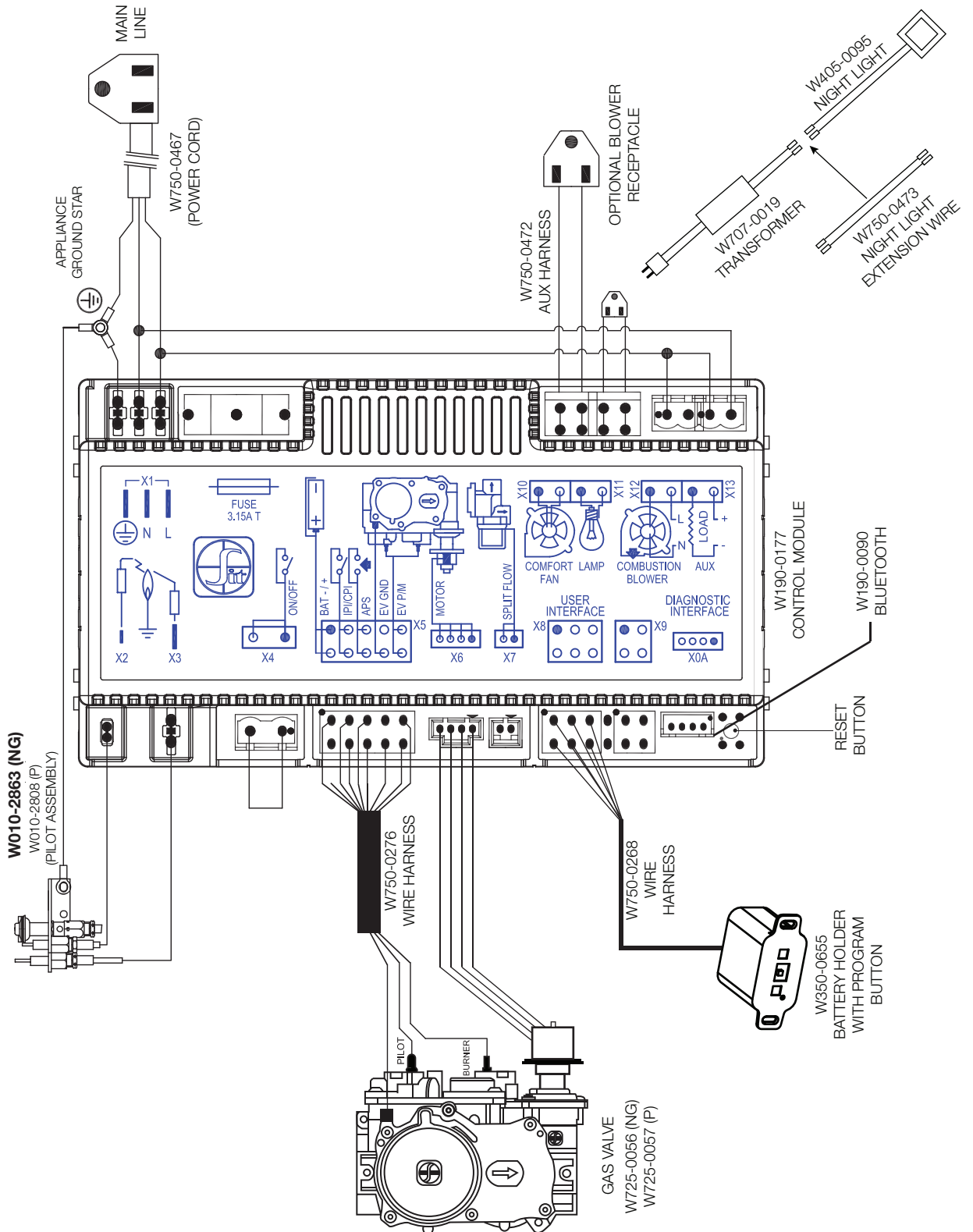

4.2 wiring diagram (GDI3E)

! WARNING

- Do not wire 110 volts to the valve or wall switch.

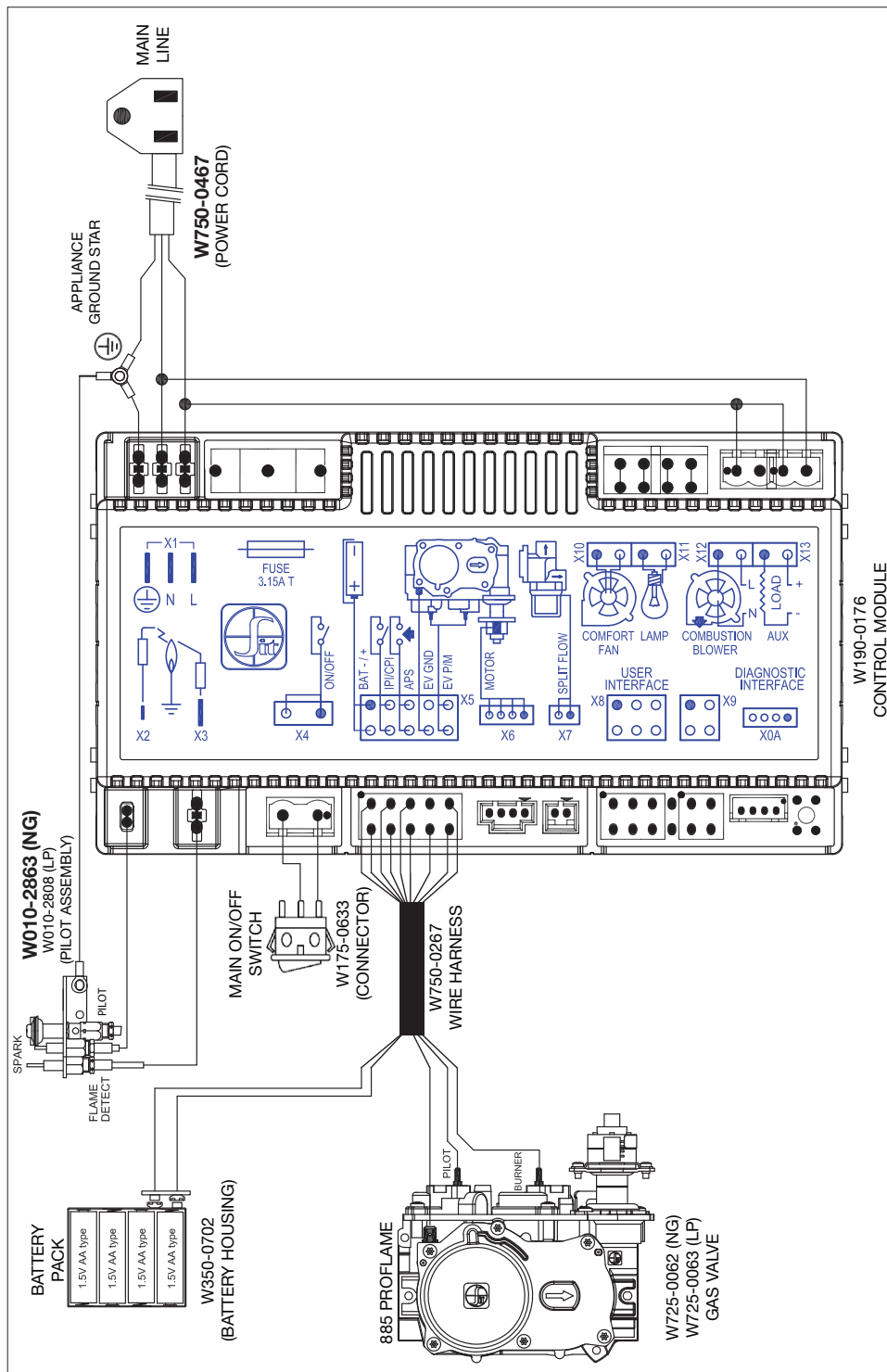
**note:**

This appliance comes equipped with a battery back-up. If this back-up is used, install 4 'AA' batteries (not supplied) into the holder and connect to the wire harness. Connect the battery holder to the wire harness before using the appliance. Place near the IPI board. If the back-up is used, it must be connected to this 6 volt battery pack (supplied). Do not connect to a 9 volt battery pack.

WARNING

- If you do not follow these instructions exactly, a fire or explosion may result causing property damage, personal injury, or loss of life.
- If applicable, always light the pilot whether for the first time or if the gas supply has run out with the glass door opened or removed.

Ensure that a continuous gas flow is at the burner before installing the door. When lit for the first time, the appliance will emit an odor for a few hours. This is a normal temporary condition caused by the “burn-in” of paints and lubricants used in the manufacturing process and will not occur again. After extended periods of non-operation such as following a vacation or a warm weather season, the appliance may emit a slight odor for a few hours. This is caused by dust particles in the heat exchanger burning off. In both cases, open a window to sufficiently ventilate the room.

For vent free appliances ONLY: if the appliance shuts off, do not relight until you provide fresh air. If appliance keeps shutting off, have it serviced. Keep burner and control compartment clean.

FOR YOUR SAFETY READ BEFORE LIGHTING

- Do not turn on if children or other at risk individuals are near the appliance.
- This appliance is equipped with a pilot which must be lit by hand while following these instructions exactly.
- Before operating, smell all around the appliance area for gas and next to the floor because some gas is heavier than air and will settle on the floor.
- Use only your hand to turn the gas control knob. Never use tools. If the knob will not turn by hand, do not try to repair it. Call a qualified service technician. Force or attempted repair may result in a fire or explosion.
- Do not use this appliance if any part has been under water. Immediately call a qualified service technician to inspect the appliance and replace any part of the control system and any gas control which has been underwater.





WHAT TO DO IF YOU SMELL GAS

- Turn off all gas to the appliance.
- Open windows.
- Do not try to light any appliance.
- Do not touch any electric switch; do not use any phone in your building
- Immediately call your gas supplier from a neighbour’s phone. Follow the gas supplier’s instructions.
- If you cannot reach your gas supplier, call the fire department.

LIGHTING INSTRUCTIONS

note:

When lighting and re-lighting, the gas knob cannot be turned from pilot to off unless the knob is depressed.

- Stop! Read the above safety information on this label.
- Remove batteries from the transmitter and set thermostat to lowest setting, if equipped.
- Turn off all electrical power to the appliance.
- Open the glass door, if equipped.
- Turn the gas knob clockwise  to the “OFF” position.
- Wait five (5) minutes to clear out any gas. If you smell gas including near the floor, STOP! Follow the instructions above in the “WHAT TO DO IF YOU SMELL GAS” section. If you don’t smell gas; close the glass door and go to the next step.
- If the appliance is equipped with flame adjustment valve turn clockwise  to “OFF”.
- Turn gas knob counter-clockwise  to the “PILOT” position. (If the appliance is equipped with an “ON/OFF” switch, ensure it is in the “ON” position.)
- Depress and hold gas knob while lighting the pilot with the push button ignitor. Keep knob fully depressed for one minute, then release. If pilot does not continue to burn, repeat steps E through I.
- With pilot lit, turn gas knob counter-clockwise  to the “ON” position.
- If equipped with the flame adjustment valve, push and turn the knob to high.
- Turn on all electrical power to the appliance and re-install the batteries into the transmitter, if equipped. Set thermostat to desired setting, if equipped.



TO TURN OFF GAS

- Set thermostat to desired setting, if equipped.
- Turn off all electrical power to the appliance if service is to be performed.
- Push in gas knob slightly and turn clockwise  to the “OFF” position. Do not force.

6.0 operation (electronic - GDI3E, GDIG3, GDIX3)

! WARNING

- If you do not follow these instructions exactly, a fire or explosion may result causing property damage, personal injury, or loss of life.
- If applicable, always light the pilot whether for the first time or if the gas supply has run out with the glass door opened or removed.

Ensure that a continuous gas flow is at the burner before installing the door. When lit for the first time, the appliance will emit an odor for a few hours. This is a normal temporary condition caused by the “burn-in” of paints and lubricants used in the manufacturing process and will not occur again. After extended periods of non-operation, such as, following a vacation or warm weather season, the appliance may emit a slight odor for a few hours. This is caused by dust particules in the heat exchanger burning off. In both cases, open a window to sufficiently ventilate the room.

FOR YOUR SAFETY READ BEFORE LIGHTING

- Do not turn on if children or other at risk individuals are near the appliance.
- This appliance is equipped with an ignition device which automatically lights the pilot. Do not try to light the pilot by hand.
- Before operating, smell all around the appliance area for gas and next to the floor because some gas is heavier than air and will settle on the floor.
- Do not use this appliance if any part has been under water. Immediately call a qualified service technician to inspect the appliance and replace any part of the control system and any gas control which has been underwater.

WHAT TO DO IF YOU SMELL GAS

- Turn off all gas to the appliance.
- Open windows.
- Do not try to light any appliance.
- Do not touch any electric switch; do not use any phone in your building
- Immediately call your gas supplier from a neighbour's phone. Follow the gas supplier's instructions.
- If you cannot reach your gas supplier, call the fire department.

LIGHTING INSTRUCTIONS

note:

This appliance is equipped with an ignition device which automatically lights the pilot. Do not try to light the pilot by hand.

- Stop! Read the above safety information on this label.
- Remove batteries from the transmitter and set thermostat to lowest setting, if equipped.
- Turn off all electrical power to the appliance.
- Open the glass door, if equipped.
- Turn the manual shut-off valve clockwise to the “OFF” position. (Shut-off valve is located on the flex connector).
- Wait five (5) minutes to clear out any gas. If you smell gas including near the floor, **STOP!** Follow the instructions above in the “WHAT TO DO IF YOU SMELL GAS” section. If you don't smell gas; close the glass door and go to the next step.
- Turn the manual shut-off valve counter clockwise to the “ON” position.
- Turn on all electrical power to the appliance and re-install the batteries into the transmitter. Set thermostat to desired setting, if equipped.
- Turn on the remote wall switch to the appliance.
- If the appliance will not operate, follow instructions “TO TURN OFF GAS” and call your service technician or gas supplier.

TO TURN OFF GAS

- Set thermostat to lowest setting, if equipped.
- Turn off the remote wall switch to the appliance.
- Turn off all electric power to the appliance if service is to be performed.
- Turn manual shutoff valve clockwise to the “OFF” positon. Do not force.

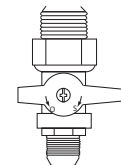

MANUAL SHUT-OFF
(SHOWN IN OFF POSITION)

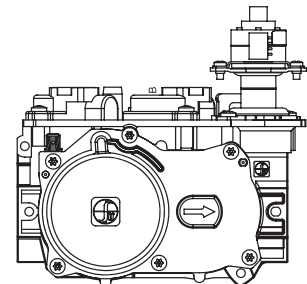

6.1 pilot on demand

This appliance is equipped with an “On Demand” intermittent pilot ignition system (IPI) which also includes a continuous pilot ignition (CPI) mode with an integrated seven day timer. This system minimizes your appliance’s carbon footprint as well as reducing its annual fuel consumption and operating costs.

In IPI mode, the pilot will ignite prior to the main burner, when the appliance is turned on using a switch, remote or from a call for heat with the thermostat (if equipped). Once the appliance is turned off (or the call for heat is satisfied), the main burner and pilot flame will shut down.

The continuous (CPI) mode is intended to enhance the performance of the appliance during the startup phase in colder climates and extreme weather by keeping the system warm when the main burner is not in use. However, the timer feature provides the convenience that the appliance automatically switches off the pilot when the appliance has not been used for seven days to save unnecessary fuel consumption.

When the CPI function is turned on, the pilot will remain on after the main burner is turned off. A timer will then begin the countdown for approximately seven days before shutting off the pilot if the appliance is not used. This countdown will reset anytime the appliance main burner is used. Therefore, if the appliance is regularly used day to day, the pilot will remain on. However, this system does not require the user to remember to turn the pilot off as summer approaches and avoids unnecessary fuel consumption while still readily turned back on when the cold weather returns.

Your appliance may be equipped with an ACS or remote control device which enables you to select IPI or CPI modes.

If your appliance is equipped with an ACS switch, it has the option to change modes. If installed with the blue wire facing up, flipping the switch UP turns on the continuous pilot with timer and flipping the switch DOWN turns on the intermittent pilot ignition. If installed with the white wire facing up, the opposite is true.

If your appliance is equipped with a remote control device capable of selecting IPI / CPI modes, refer to remote operating instructions.

In order to start your pilot, turning the main burner on with the switch, remote or thermostat and then turning it off will reactivate the continuous pilot mode and reset the seven day timer.

For further information, refer to www.napoleon.com/pilotondemand.



6.2 ACS switch location (GDI3E)

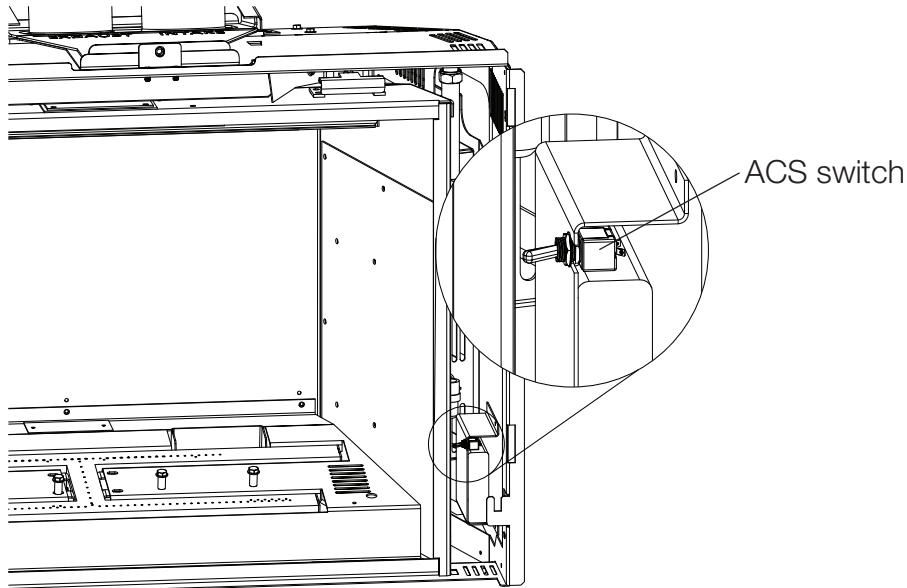

7.0 adjustments

7.1 pilot burner adjustment

Adjust the pilot screw to provide properly sized flame. Turn in a clockwise direction to reduce the gas flow.

Check Pressure Readings:

Inlet pressure can be checked by turning screw (A) counter-clockwise 2 or 3 turns and then placing pressure gauge tubing over the test point. Gauge should read as described on the chart below. Check pressure with main burner operating on "HI".

Outlet pressure can be checked the same as above using screw (B). Gauge should read as described on the chart below. Check pressure with main burner operating on "HI".

After taking pressure readings, be sure to turn screws clockwise firmly to reseal. Do not overtorque.

Leak test with a soap and water solution.

Prior to pilot adjustment, ensure that the pilot assembly has not been painted. If overspray or painting of the pilot assembly has occurred remove the paint from the pilot assembly, or replace. Fine emery cloth or a synthetic scrub pad (such as Scotch-Brite™) can be used to remove the paint from the pilot hood, electrode and flame sensor.

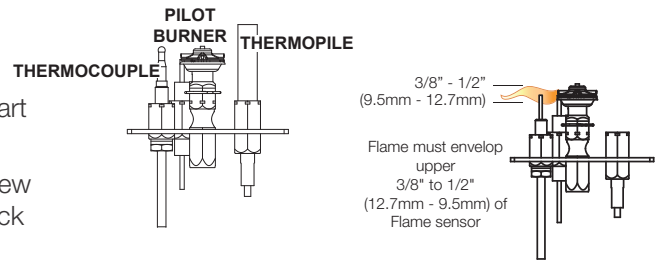

MILLIVOLT
(GDI3)

ELECTRONIC
(GDI3E / GDIG3 /
GDIX3)

Pressure	Natural Gas (inches)	Natural Gas (millibars)	Propane (inches)	Propane (millibars)
Inlet	*7" (minimum 4.5")	17.4mb (minimum 11.2mb)	13" (minimum 11")	32.4mb (minimum 27.4mb)
Outlet	3.5"	8.7mb	10"	24.9mb

***Maximum inlet pressure not to exceed 13"**

7.2 venturi adjustment

This appliance has an air shutter that has been factory set open according to the chart below:

Regardless of venturi orientation, closing the air shutter will cause a more yellow flame, but can lead to carbonization. Opening the air shutter will cause a more blue flame, but can cause flame lifting from the burner ports. The flame may not appear yellow immediately; allow 15 to 30 minutes for the final flame colour to be established.

AIR SHUTTER ADJUSTMENT MUST ONLY BE DONE BY A QUALIFIED INSTALLER.

note:

It is important that the orifice is securely inserted into the venturi.

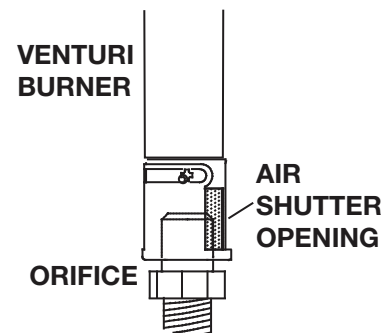

Venturi Adjustment Chart

	GDI3	GDI3E	GDIG3	GDIX3
NG	1/16" (1.6mm)		1/8" (3.2mm)	
P	3/16" (4.7mm)			1/4" (6.4mm)

7.3 flame characteristics

It is important to periodically perform a visual check of the pilot and burner flames. Compare them to the illustration provided. If any flames appear abnormal, call a service person.

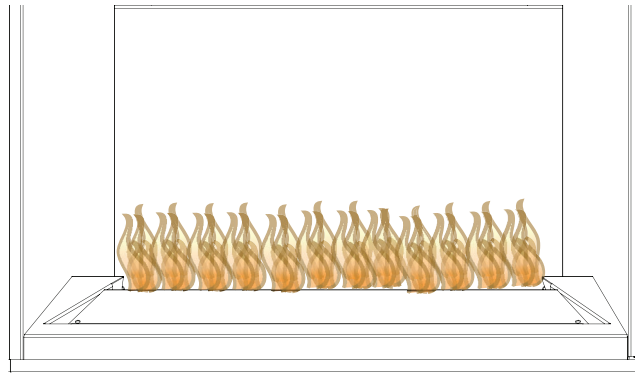

GDIG3

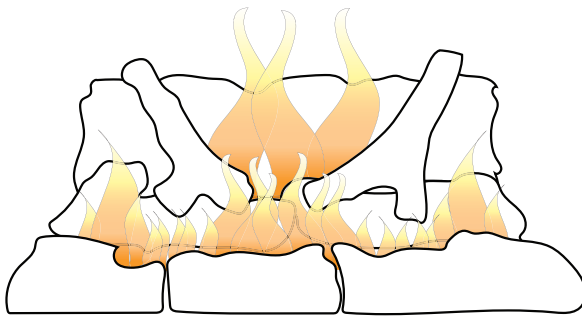

GDI3 / GDI3E

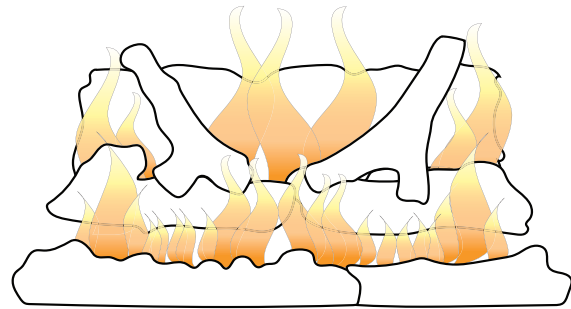

GDIX3

7.4 optional wall switch

! WARNING

- Do not connect either the wall switch, thermostat or gas valve directly to 110 volt electricity.

For ease of accessibility, an optional remote wall switch or millivolt thermostat may be installed in a convenient location. Route a 2 strand, solid core millivolt wire from the valve to the wall switch or millivolt thermostat. The recommended maximum lead length depends on wire size:

WIRE SIZE	MAX. LENGTH
14 gauge (1.8mm)	100 feet (30.5m)
16 gauge (1.5mm)	60 feet (18.3m)
18 gauge (1.2mm)	40 feet (12.2m)

Disconnect the existing wires from terminals 1 and 3 (from the ON/OFF switch) and replace with the leads from the wall switch / millivolt thermostat.

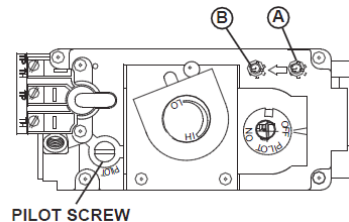

PILOT SCREW

8.0 maintenance

WARNING

- Turn off the gas and electrical power before servicing the appliance.
- Appliance may be hot. Do not service until appliance has cooled.
- Do not use abrasive cleaners on glass.
- Do not paint the pilot assembly.

This appliance and its venting system should be inspected before use and at least annually by a qualified service person. The following suggested checks should be performed by a qualified technician. The appliance area must be kept clear and free of combustible materials, gasoline, or other flammable vapors and liquids. The flow of combustion and ventilation air must not be obstructed.

note:

Caution: Label all wires prior to disconnection when servicing controls. Wiring errors can cause improper and dangerous operation. Verify proper operation after servicing.

1. In order to properly clean the burner and pilot assembly, remove the logs, rocks and/or glass to expose both assemblies.
2. Keep the control compartment, media, burner, air shutter opening and the area surrounding the appliance clean by vacuuming or brushing, at least once a year.
3. Check to see that all burner ports are burning. Clean out any of the ports which may not be burning or are not burning properly.
4. Check to see that the pilot flame is large enough to engulf the flame sensor and/or thermocouple / thermopile as well as it reaches the burner.
5. If your appliance is equipped with a safety barrier, cleaning may be necessary due to excessive lint / dust from carpeting, pets, etc. simply vacuum using the brush attachment.
6. If your appliance is equipped with relief doors, ensure the system performs effectively. Check that the gasket is not worn or damaged. Replace if necessary.
7. Replace the cleaned logs, rocks or glass. Failure to properly position the media may cause carboning which can be distributed in the surrounding living area, inside the firebox and on exterior surfaces surrounding vent termination.
8. Check to see that the main burner ignites completely on all ports when turned on. A 5 to 10 second total light-up period is satisfactory. If ignition takes longer, consult your local authorized dealer / distributor.
9. Visually inspect the appliance for carbon build up. Using a small whisk or brush, brush off the carbon and vacuum up or sweep into garbage.
10. **This step is not applicable for Vent Free appliances:** Check to see that the appliance is venting correctly. Ensure chimney system is safe and unobstructed. (If for any reason the vent air intake system is disassembled, re-install and re-seal per the instructions provided for the initial installation).

8.1 annual maintenance

WARNING

- Annual maintenance should be performed by a qualified service technician
- The firebox becomes very hot during operation. Let the appliance cool completely or wear heat resistant gloves before conducting service.
- Never vacuum hot embers.
- Do not paint the pilot assembly

- This appliance will require maintenance which should be planned on an annual basis.
- Service should include cleaning, battery replacement, venting inspection and inspection of the burner, media, and firebox. Refer to the door removal section and remove the door as instructed.
- Carefully remove media if necessary (logs, glass, brick panels, etc.).
- Using a vacuum with soft brush attachment, gently remove any dirt, debris, or carbon build up from the logs, firebox, and burner. For glass media, follow the installation instructions for pre-cleaning.
- Gently remove any build-up on the pilot assembly including thermopile, thermocouple, flame sensor, and igniter (if equipped).

note:

Clean flame sensor using a fine emery cloth or a synthetic scrub pad (such as Scotch-Brite™) to remove any oxides. Clean the pilot assembly using a vacuum with a soft brush attachment. It is important that the pilot assembly is not painted.

- Inspect all accessible gaskets and replace as required.
- If equipped with a blower, access the blower and clean using a soft brush and vacuum.
- Re-assemble the various components in reverse order.
- Inspect the relief system. The appliance relieves through the main glass door or through the flaps on the firebox top. Ensure they open freely, and close sealed.
- Check the gas control valve pilot and Hi / Lo knobs move freely, if equipped. Replace if any stiffness in movement is experienced.
- Check for gas leaks on all gas connections up and downstream from the gas valve including pilot tube connections.

8.2 care of glass

WARNING

- Do not clean glass when hot! Do not use abrasive cleaners to clean glass.

Buff lightly with a clean dry soft cloth to remove accumulated dust or fingerprints. Clean both sides of the glass after the first 10 hours of operation with an ammonia-free glass cleaner.

note:

Vinegar-based glass cleaners have demonstrated an ability to provide a clean, streak free glass surface.

Thereafter, clean as required. If the glass is not kept clean permanent discoloration and / or blemishes may result. Contact you local authorized dealer / distributor for complete cleaning instructions.

Razor blades, steel wool, or other metallic objects must not be used on both surfaces of the glass. Doing so can remove a thin layer of metal from the razor blades, steel wool, or other metallic objects that may then be deposited onto the coating. This can result in a discoloured stain or scratch-like mark. More importantly, this can scratch the glass surface, thereby reducing its strength.

Do not operate the appliance with broken glass, as leakage of flue gases may result.

Contact your local authorized dealer / distributor for complete cleaning instructions.

If the glass should ever crack or break while the fire is burning, do not open the door until the fire is out. Do not operate the appliance until the glass has been replaced. Contact you local authorized dealer / distributor for replacement parts. **DO NOT SUBSTITUTE MATERIALS.**

This appliance is factory equipped with 5mm ceramic glass. Use only replacement parts as supplied by the appliance manufacturer. **DO NOT SUBSTITUTE MATERIALS.**

maintenance

8.3 care of plated parts

If the appliance is equipped with plated parts, you must clean fingerprints or other marks from the plated surfaces before operating the appliance for the first time. Use an ammonia-free or vinegar-based cleaner and a towel to clean. If not cleaned properly before operating for the first time, the marks can cause permanent blemishes on the plating. After the plating is cured, the fingerprints and oils will not affect the finish and little maintenance is required, just wipe clean as needed. Prolonged high temperature burning with the door ajar may cause discolouration on plated parts.

note:

The protective wrap on plated parts is best removed when the assembly is at room temperature but this can be improved if the assembly is warmed (i.e. using a hair dryer or similar heat source).

8.4 door glass replacement

! WARNING

- Do not use substitute materials.
- Glass may be hot. Do not touch glass until cooled.
- Care must be taken when removing and disposing of any broken door glass or damaged components. Be sure to vacuum up any broken glass from inside appliance before operation.
- Do not strike, slam, or scratch. Do not operate appliance with glass removed, cracked, broken, or scratched.

Replacement glass/frame assembly shall be replaced as a complete unit as supplied by the appliance manufacturer.

8.5 media tray installation

Secure the media tray to the burner using 6 screws (W570-0001).

When removing the media tray, make sure the glass media is away from the center of the screen, exposing the burner. Remove screws and lift media tray out.

When replacing the burner, absolutely no glass media can be surrounding the orifice.

hint:

If glass surrounds the orifice, insert a clean bag into a vacuum cleaner and vacuum out glass media. Replacement glass media can be ordered from Wolf Steel Ltd.

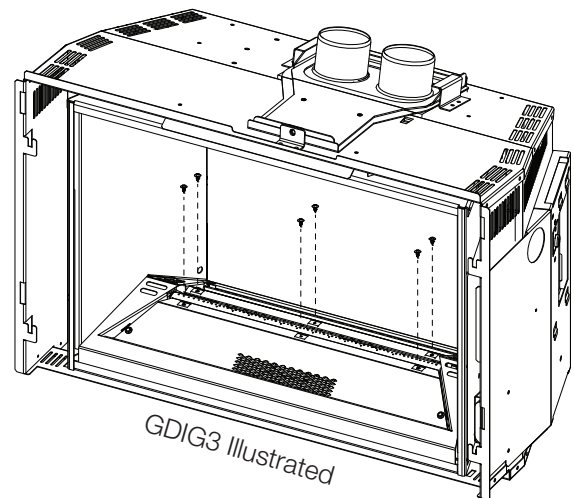

8.6 night light™ replacement (GDIG3 / GDIX3)

Your appliance comes equipped with our “Night Light™”. The light has been pre-wired and is controlled from the remote control.

If the lamp or lens needs to be replaced, follow the instructions below.

- A. Unplug the appliance (plug located on right side of appliance).
- B. Remove the 2 screws holding the light shield in place.
- C. Remove the 4 screws that secure the lens frame (**Fig. 6-1**). This frame retains the glass lens. The lamp can now be accessed.

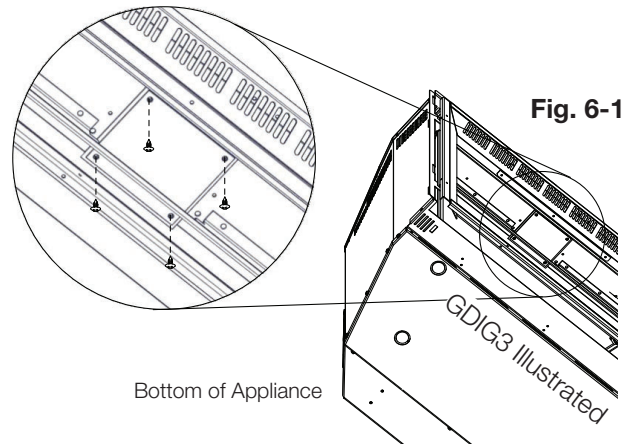

note:

Do not handle the lamp (bulb) with bare fingers. Protect them with a clean, dry cloth.

The lamp will pull straight out of the socket. Replace with Wolf Steel parts only, as lamp and lens are special "high temperature" products. When re-installing, ensure integrity of gasket seal.

THE FIREBOX MUST BE SEALED.

Over-tightening the screws could break the lens. “Light Leakage” from the upper area may be observed. The holes in the lamp housing are necessary for ventilation and must not be covered.

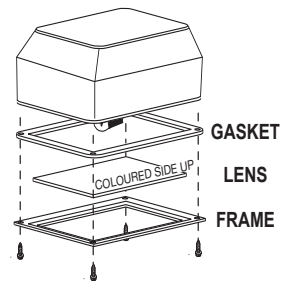

8.7 restricting vertical vents

Your appliance comes with restrictor plate fully closed. If carboning becomes an issue, adjust the restrictor plate by loosening the four screws and pulling the plate forwards or backwards (**Fig. 6-2**). Re-tighten the screws.

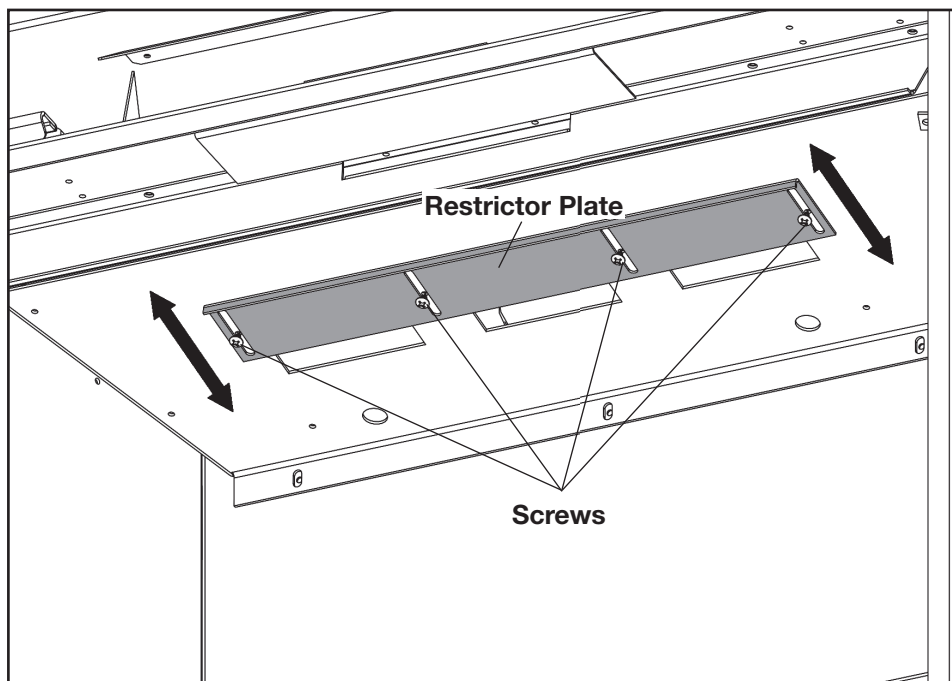

Fig. 6-2

8.8 valve train replacement

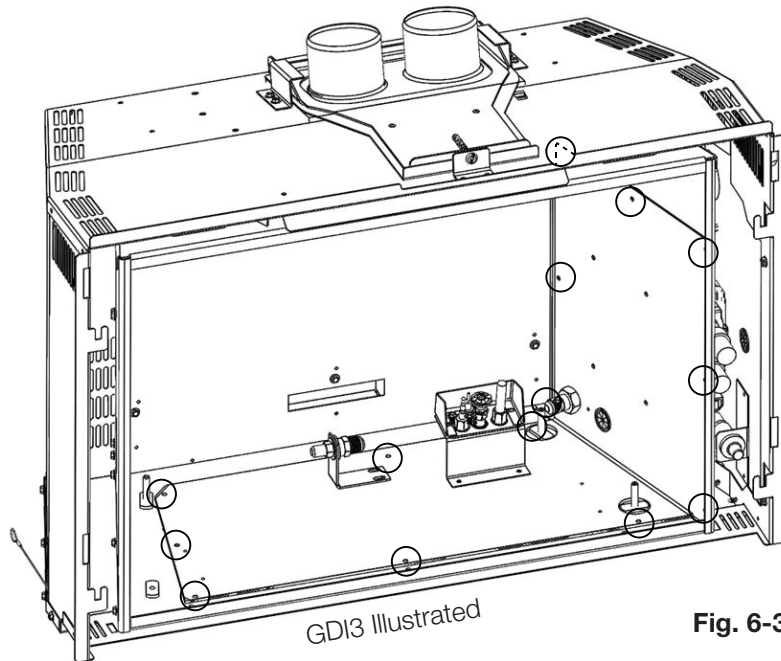

Fig. 6-3

- A. Remove safety barrier and glass door (see "safety barrier & door removal / installation" section).
- B. Remove media tray (see "media tray installation" section) and burners.
- C. Remove porcelain radiant panels (PRPs) or brick panels (if applicable).
- D. Remove the 14 screws holding the valve train in place (**Fig. 6-3**).

note:

A new gasket may be required when reinstalling the valve train assembly. Contact your local authorized dealer / distributor for more information.

- E. Carefully lift the valve train assembly out far enough to access the manual shut off valve and turn it to the off position. Disconnect any wires, and then lift the valve train out of the appliance.

! WARNING

- Failure to position the parts in accordance with this manual or failure to use only parts specifically approved with this appliance may result in property damage or personal injury.

Contact your dealer for questions concerning prices and policies on replacement parts. Normally, all parts can be ordered through your Authorized dealer / distributor.

For warranty replacement parts, a photocopy of the original invoice will be required to honour the claim.

When ordering replacement parts always give the following information:

- Model & Serial Number of appliance
- Installation date of appliance
- Part number
- Description of part
- Finish

Parts, part numbers, and availability are subject to change without notice.

Parts identified as stocked will be delivered within 2 to 5 business days for most delivery destinations.

Parts not identified as stocked will be delivered within a 2 to 4 week period, for most cases.

Parts identified as 'SO' are special order and can take up to 90 days for delivery.

9.1 overview

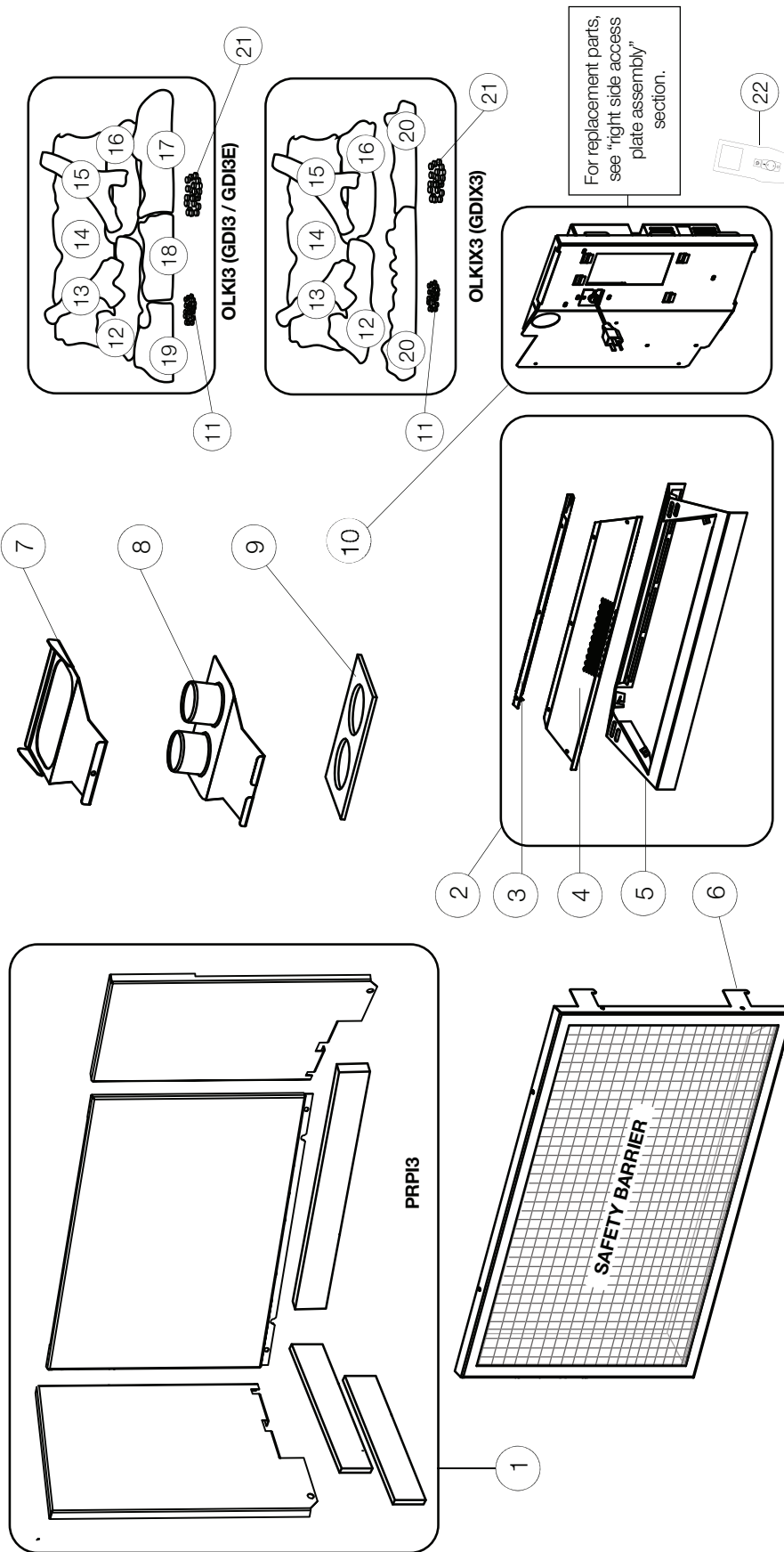

Items may not appear exactly as illustrated

Ref. No.	Part number	Description	Stocked	Ref. No.	Part number	Description	Stocked
1	PRPI3	Porcelain reflective radiant panels		12	W135-0780	Log, left (OLKI/X3)	
2	W010-2629	Media tray assembly (GDIG3 only)		13	W135-0782	Log, left crossover (OLKI/X3)	
3	W565-0132	Rear burner screen (GDIG3 only)		14	W135-0778	Log, rear (OLKI/X3)	
4	W565-0131	Front burner screen (GDIG3 only)		15	W135-0781	Log, right crossover (OLKI/X3)	
5	W200-0371	Media tray cover (GDIG3 only)		16	W135-0779	Log, right (OLKI/X3)	
6	W010-4414	Safety barrier assembly		17	W135-0785	Log, right charcoal (OLKI3)	
7	W010-4790	Assembly, collar		18	W135-0784	Log, centre charcoal (OLKI3)	
8	W010-4791	Assembly, vent slide		19	W135-0783	Log, left charcoal (OLKI3)	
9	W290-0183	Vent connection gasket	Yes	20	W135-0786	Log, charcoal strip (left / right) (OLKI3)	
10	W010-4412	RS access plate assembly	Yes	21	W550-0001	Charcoal embers	Yes
11	W361-0016	Glowing embers	Yes	22	W660-0126-SER	Proflame remote (GDIG/X3)	Yes

9.2 right side access plate assembly

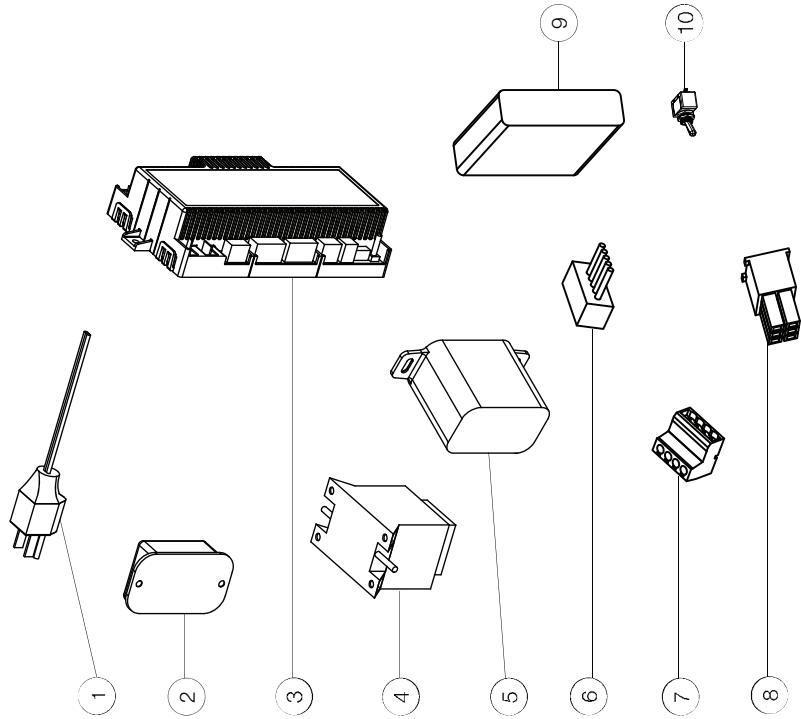

Items may not appear exactly as illustrated

Ref. No.	Part number	Description	Stocked
1	W750-0467	Wire harness (10 ft. power cord)	
1	W750-0190	Wire harness (power cord) (GDI3 only)	
1	W750-0492	Wire harness (GDI3E)	
2	W190-0090	Bluetooth control module (GDI/G/X3)	Yes
3	W190-0177	Proflame 2 control (GDI/G/X3)	Yes
3	W190-0176	Proflame 2 control (GDI3E)	Yes
4	W707-0019	Transformer (GDI/G/X3)	Yes
5	W350-0655	Proflame 2 battery housing (GDI/G/X3)	Yes
6	W750-0276	Wire harness (GDI/G/X3)	Yes
6	W750-0267	Wire harness (GDI3E)	Yes
7	W750-0472	Aux. harness (GDI/G/X3/E3)	Yes
8	W750-0268	Wire, battery housing (GDI/G/X3)	Yes
9	W350-0702	Battery housing (GDI3E)	Yes
10	W750-0191	ACS switch (GDI3E)	Yes

9.3 valve train assembly (GDI3)

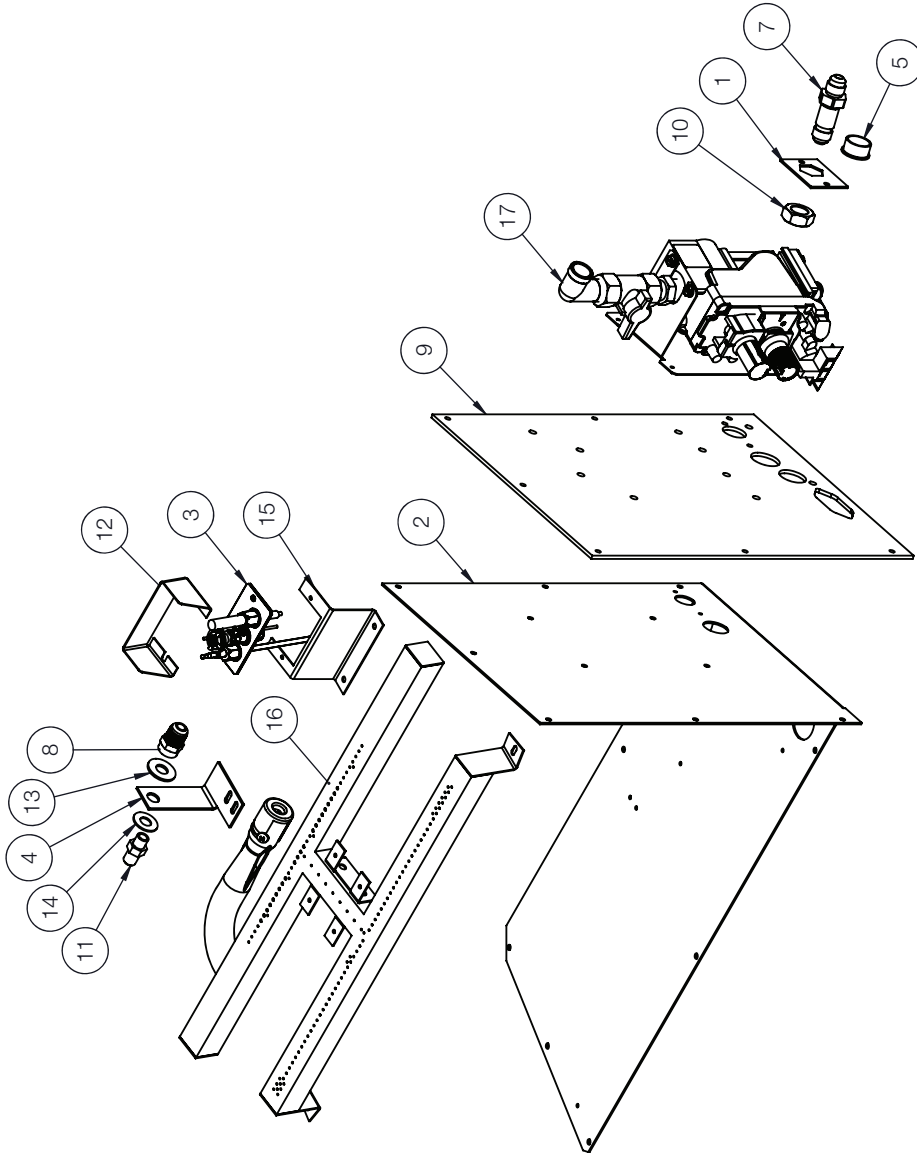

Items may not appear exactly as illustrated.

Ref. No.	Part Number	Description	Stocked	Ref. No.	Part Number	Description	Stocked
1	W500-0994	Securing plate		10	W450-0050	5/8"-18 nut	
2	W710-0115	Burner tray		11	W456-0043	Burner orifice #43 (NG)	Yes
3	W010-0798	Pilot assembly	Yes	11	W456-0053	Burner orifice #53 (P)	Yes
4	W080-1915	Orifice bracket		12	W585-0931	Pilot shield	
5	W105-0001	Bushing		13	W735-0019	7/16" washer	
6	W175-0281	9" flex connection		14	W735-0051	3/8" washer	
7	N255-0002-SER	3/8 union bulkhead fitting	Yes	15	W080-1910	Pilot bracket	
8	W255-0002	3/8 tube to 1/8 pipe fitting		16	W100-0244	Burner	
9	W290-0866	Burner tray gasket		17	W010-4500	Valve assembly	

9.4 valve train assembly (GDIG3)

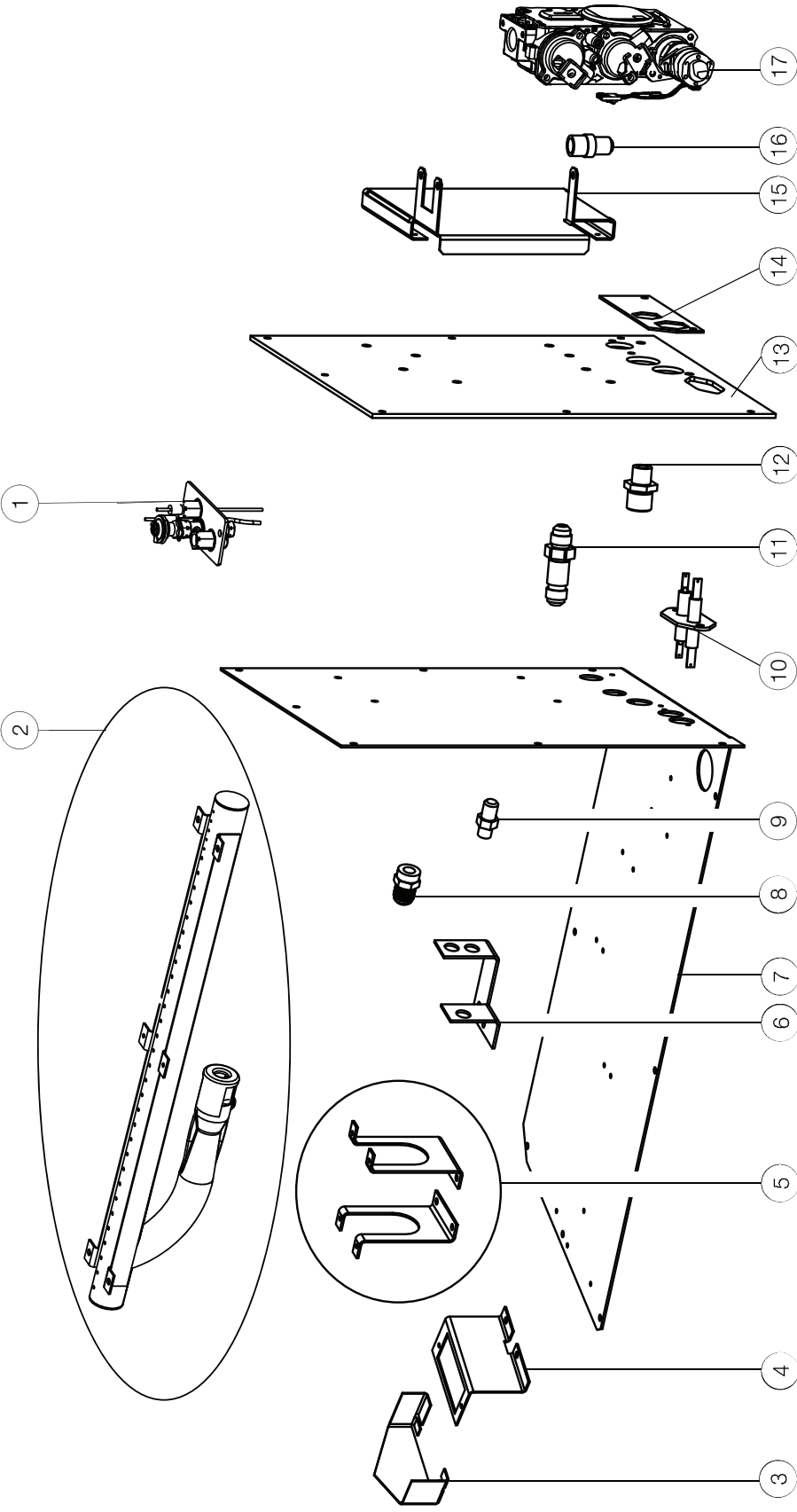

Items may not appear exactly as illustrated.

Ref. No.	Part Number	Description	Stocked
1	W010-2863	Pilot assembly	Yes
2	W010-4470	Tube burner assembly	
3	W350-0899	Pilot housing	
4	W080-1895	Pilot bracket	
5	W080-1194	Tube burner bracket	
6	W080-1189	Orifice bracket	
7	W710-0114	Burner tray	
8	W255-0002	3/8" tube to 1/8" NPT pipe	Yes
9	W456-0042	Burner orifice #42 (NG)	
9	W456-0053	Burner orifice #53 (P)	Yes

Ref. No.	Part Number	Description	Stocked
10	W240-0010	Electrode, double bulkhead	Yes
11	N255-0002-SER	Bulkhead fitting	Yes
12	W255-0021	Fitting	
13	W290-0866	Burner tray gasket	
14	W500-1000	Securing plate	
15	W080-1907	Valve bracket	
16	W445-0038	Connector 3/8" tube to 3/8" pipe	Yes
17	W725-0056	Valve (NG)	Yes

9.5 valve train assembly (GDIX3)

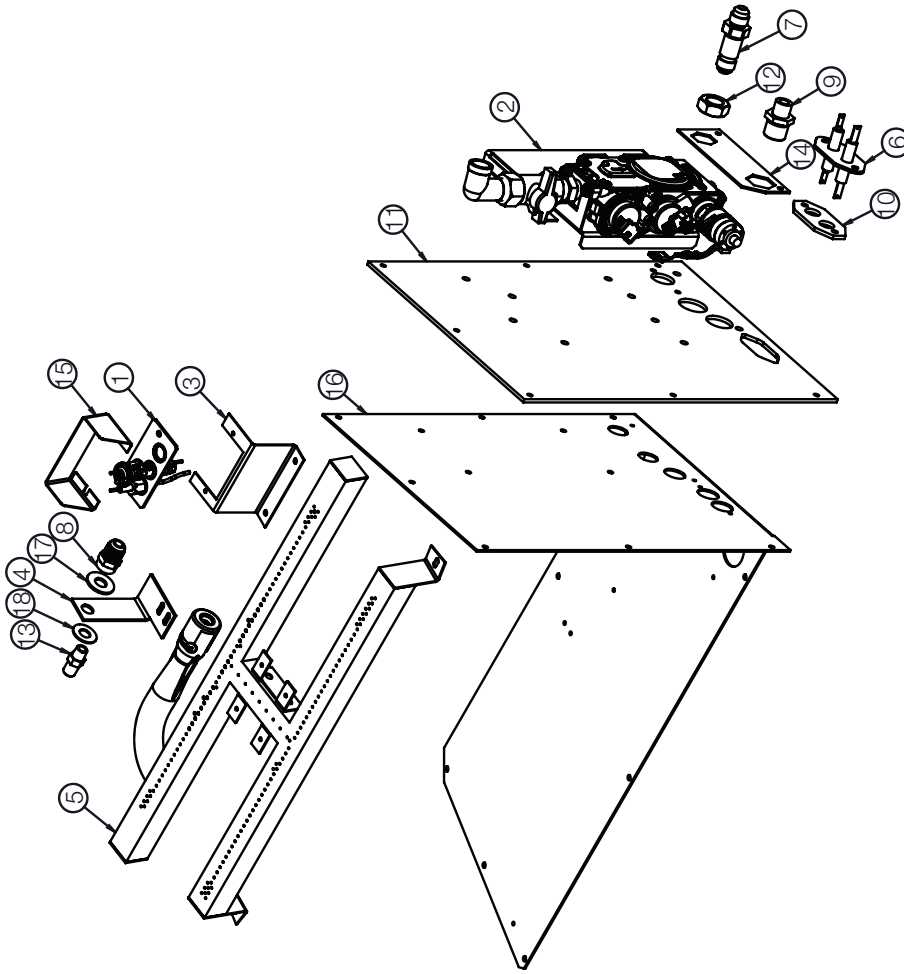

Items may not appear exactly as illustrated.

Ref. No.	Part Number	Description	Stocked
1	W010-2863	Pilot assembly	Yes
2	W010-4491	Valve assembly	
3	W080-1910	Pilot bracket	
4	W080-1915	Orifice bracket	
5	W100-0245	Burner	
6	W240-0010	Double electrode	Yes
7	N255-0002	3/8 union bulkhead fitting	Yes
8	W255-0002	3/8 tube to 1/8 pipe fitting	
9	W255-0021	Bulkhead	
10	W290-0137	Double bulkhead gasket	
Ref. No.	Part Number	Description	Stocked
11	W290-0866	Burner tray gasket	
12	W450-0050	5/8"-18 nut	
13	W456-0037	Burner orifice #37 (NG)	Yes
13	W456-0052	Burner orifice #52 (P)	Yes
14	W500-0988	Securing plate	
15	W585-0931	Pilot shield	
16	W710-0118	Burner tray	
17	W735-0019	7/16" washer	
18	W735-0051	3/8" washer	

9.6 valve train assembly (GDI3E)

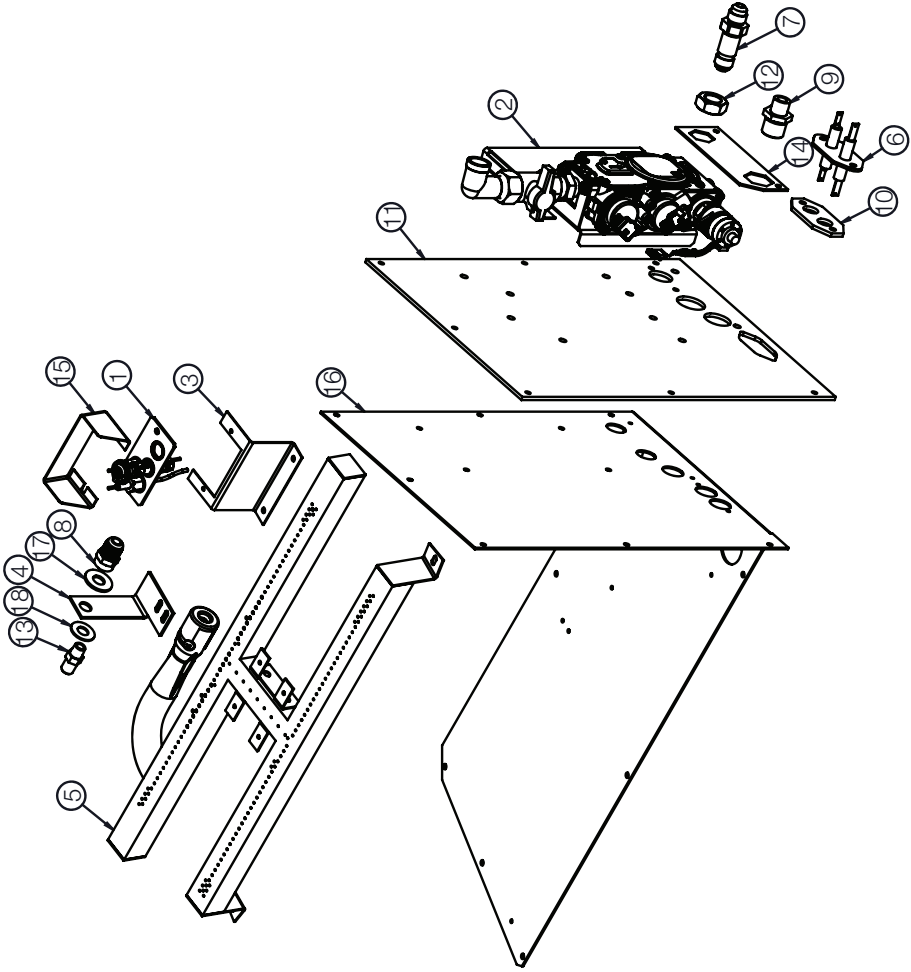

Items may not appear exactly as illustrated.

Ref. No.	Part Number	Description	Stocked	Ref. No.	Part Number	Description	Stocked
1	W010-2863	Pilot assembly	Yes	11	W290-0866	Burner tray gasket	
2	W010-4761	Valve assembly		12	W450-0050	5/8"-18 nut	
3	W080-1910	Pilot bracket		13	W456-0043	Burner orifice #43 (NG)	Yes
4	W080-1915	Orifice bracket		13	W456-0053	Burner orifice #53 (P)	Yes
5	W100-0244	Burner		14	W500-0988	Securing plate	
6	W240-0010	Double electrode	Yes	15	W585-0931	Pilot shield	
7	N255-0002	3/8 union bulkhead fitting	Yes	16	W710-0118	Burner tray	
8	W255-0002	3/8 tube to 1/8 pipe fitting		17	W735-0019	7/16" washer	
9	W255-0021	Bulkhead		18	W735-0051	3/8" washer	
10	W290-0137	Double bulkhead gasket					

9.7 firebox top assembly

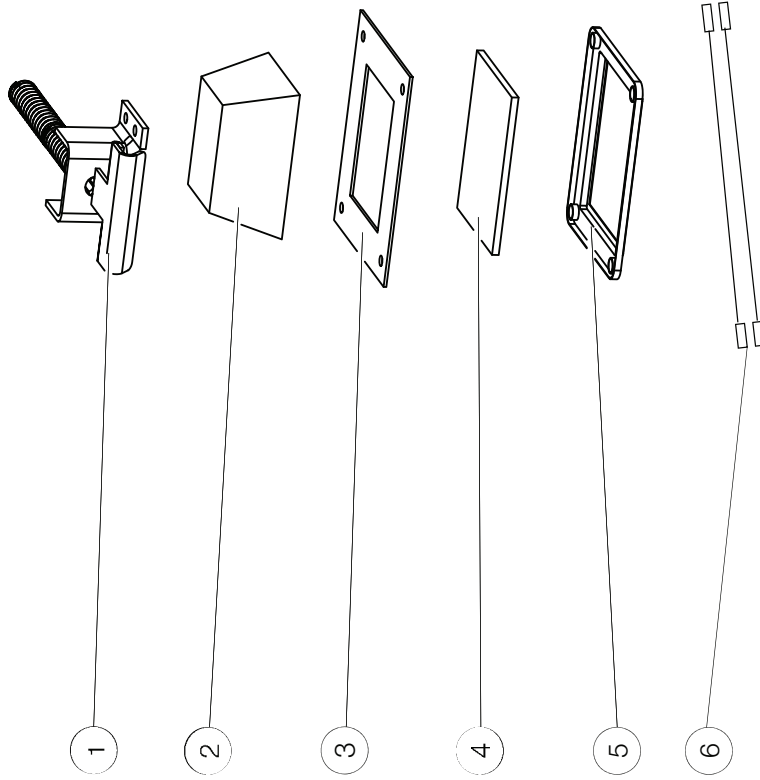

Items may not appear exactly as illustrated

Ref. No.	Part number	Description	Stocked
1	W010-3684	Door latches (X2)	
2	W405-0095	High temperature light assembly	
3	W290-0080	Cover plate gasket	Yes
4	W300-0086	Ceramic glass lens	Yes
5	W280-0071	Lens frame	Yes
6	W750-0473	Night light extension wire (GDIG/X3)	

WARNING

- Always light the pilot whether for the first time or if the gas supply has run out, with the glass door open or removed.
- Turn off gas and electrical power before servicing the appliance.
- Appliance may be hot. Do not service until appliance has cooled.
- Do not use abrasive cleaners

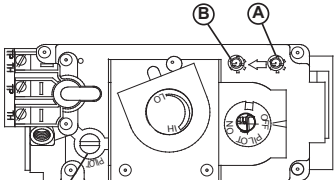
symptom	problem	test solution													
Main burner flame is a blue, lazy, transparent flame.	Blockage in vent.	- Remove blockage. In really cold conditions, ice buildup may occur on the terminal and should be removed as required. To minimize this from happening again, it is recommended that the vent lengths that pass through unheated spaces (attics, garages, crawl spaces) be wrapped with an insulated mylar sleeve. Prevent sleeve from sagging. Contact your local authorized dealer for more information.													
Main burner goes out; pilot stays on.	Pilot flame is not large enough or not engulfing the thermopile.	- Turn up the pilot flame. - Replace pilot assembly.													
	Thermopile shorting.	- Clean thermopile connection to the valve. Reconnect. - Replace thermopile / valve.													
	Remote wall switch wire is too long; too much resistance in the system.	- Shorten wire to correct length or wire gauge.													
	Faulty thermostat or switch.	- Replace.													
Main burner goes out; pilot goes out.	Refer to "MAIN BURNER GOES OUT; PILOT STAYS ON"														
	Vent is blocked	- Check for vent blockage.													
	Vent is re-circulating	- Check joint seals and installation													
	Flexible vent has become disconnected from appliance.	- Re-attach to appliance. - Cap was not replaced.													
Flames are consistently too large or too small. Carboning occurs.	Appliance is over-fired or underfired.	- Check pressure readings: Inlet pressure can be checked by turning screw (A) counter-clockwise 2 or 3 turns and then placing pressure gauge tubing over the test point. Gauge should read as described on the chart below. Check that main burner is operating on 'HI'. Outlet pressure can be checked the same as above using screw (B). Gauge should read as described on the chart below. Check that main burner is operating on 'HI'. AFTER TAKING PRESSURE READINGS, BE SURE TO TURN SCREWS CLOCKWISE FIRMLY TO RESEAL. DO NOT OVER TORQUE. Leak test with a soap and water solution.													
		<table border="1" style="width: 100%; border-collapse: collapse; text-align: center;"> <thead> <tr> <th style="background-color: #cccccc;">Pressure</th> <th style="background-color: #cccccc;">Natural Gas (inches)</th> <th style="background-color: #cccccc;">Natural Gas (millibars)</th> <th style="background-color: #cccccc;">Propane (inches)</th> <th style="background-color: #cccccc;">Propane (millibars)</th> </tr> </thead> <tbody> <tr> <td style="background-color: #cccccc;">Inlet</td> <td>* 13" (MIN. 4.5")</td> <td>17.4mb (MIN. 11.2mb)</td> <td>13" (MIN. 11")</td> <td>32.4mb (MIN. 27.4mb)</td> </tr> <tr> <td style="background-color: #cccccc;">Outlet</td> <td>3.5"</td> <td>8.7mb</td> <td>10"</td> <td>24.9mb</td> </tr> </tbody> </table>	Pressure	Natural Gas (inches)	Natural Gas (millibars)	Propane (inches)	Propane (millibars)	Inlet	* 13" (MIN. 4.5")	17.4mb (MIN. 11.2mb)	13" (MIN. 11")	32.4mb (MIN. 27.4mb)	Outlet	3.5"	8.7mb
Pressure	Natural Gas (inches)	Natural Gas (millibars)	Propane (inches)	Propane (millibars)											
Inlet	* 13" (MIN. 4.5")	17.4mb (MIN. 11.2mb)	13" (MIN. 11")	32.4mb (MIN. 27.4mb)											
Outlet	3.5"	8.7mb	10"	24.9mb											
	 <p style="text-align: center;">PILOT SCREW</p> <p style="text-align: center;">* Maximum inlet pressure not to exceed 13"</p>														
	Air shutter improperly adjusted.	- Return air shutter to specified opening, see "venturi adjustment" section.													
Carbon is being deposited on glass, logs, rocks, media or combustion chamber surfaces.	Air shutter is blocked.	- Ensure air shutter opening is free of lint or other obstructions.													
	Flame is impinging on the glass, logs, rocks, media or combustion chamber.	- Ensure the media is positioned correctly in the appliance. - Open air shutter to increase the primary air. - Check the input rate: check the manifold pressure and orifice size as specified by the rating plate. - Ensure door gasketing is not broken or missing and the seal is tight. - Ensure vent liners are free of holes and well sealed at all joints. - Check that minimum rise per foot (meters) has been adhered to for any horizontal venting.													
White / grey film forms.	Sulphur from fuel is being deposited on glass, logs or combustion chamber surfaces.	- Clean the glass with a recommended gas fireplace glass cleaner. DO NOT CLEAN GLASS WHEN HOT. - If deposits are not cleaned off regularly, the glass may become permanently marked.													
Exhaust fumes smelled in room, headaches.	Appliance is spilling. (This is not applicable in outdoor appliances)	- Check door seal. - Check for exhaust damage. - Check that venting is installed correctly. - Room is in negative pressure; increase fresh air supply.													

troubleshooting (millivolt - GDI3)

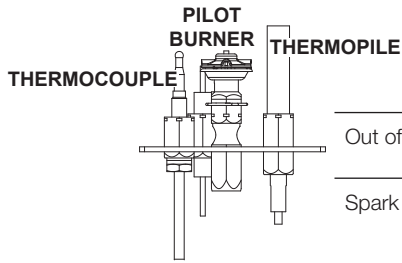

symptom	problem	test solution
Pilot will not light.	No spark at pilot burner.	<ul style="list-style-type: none"> - Check if pilot can be lit by a match. - Check that the wire is connected to the push button ignitor. - Check if the push button ignitor needs tightening. - Replace the wire if the wire insulation is broken or frayed. - Replace the electrode if the ceramic insulator is cracked or broken. - Replace the push button ignitor
	Out of propane gas.	<ul style="list-style-type: none"> - Fill the tank.
	Spark gap is incorrect.	<ul style="list-style-type: none"> - Spark gap should be 0.150" (3.8mm) to 0.175" (4.5mm) from the electrode tip and the pilot burner. To ensure proper electrode location, tighten securing nut (finger tight plus 1/4 turn).
	No gas at the pilot burner.	<ul style="list-style-type: none"> - Check that the manual valve is turned on. - Check the pilot orifice for blockage. - Replace the valve. - Call the gas distributor.
Pilot goes out when the gas knob is released. The gas valve has an interlock device which will not allow the pilot burner to be lit until the thermocouple has cooled. Allow approximately 60 seconds for the thermocouple to cool.	System is not correctly purged	<ul style="list-style-type: none"> - Purge the gas line.
	Out of propane gas.	<ul style="list-style-type: none"> - Fill the tank.
	Pilot flame is not large enough.	<ul style="list-style-type: none"> - Turn up the pilot flame.
	Pilot flame is not engulfing the thermocouple	<ul style="list-style-type: none"> - Gently twist the pilot head to improve the flame pattern around the thermocouple.
	Thermocouple shorting / faulty.	<ul style="list-style-type: none"> - Loosen and tighten thermocouple. - Clean thermocouple and valve connection. - Replace thermocouple. - Replace valve.
Faulty valve.	<ul style="list-style-type: none"> - Replace. 	
Pilot burning; no gas to main burner; gas knob is on 'HI'; wall switch / thermostat is on.	Thermostat or switch is defective	<ul style="list-style-type: none"> - Connect a jumper wire across the wall switch terminals; if main burner lights, replace switch / thermostat.
	Wall switch wiring is defective.	<ul style="list-style-type: none"> - Disconnect the switch wires & connect a jumper wire across terminals 1 & 3; if the main burner lights, check the wires for defects and/or replace wires.
	Main burner orifice is plugged.	<ul style="list-style-type: none"> - Remove stoppage in orifice.
	Faulty valve.	<ul style="list-style-type: none"> - Replace.
Pilot goes out while standing; Main burner is in 'OFF' position.	Gas piping is undersized.	<ul style="list-style-type: none"> - Turn on all gas appliances and see if pilot flame flutters, diminishes or extinguishes, especially when main burner ignites. Monitor appliance supply working pressure.
		<ul style="list-style-type: none"> - Check if supply piping size is to code. Correct all undersized piping.
Flames are very aggressive.	Door is ajar.	<ul style="list-style-type: none"> - Ensure the mechanical means of securing the door is providing a tight seal.
	Venting action is too great.	<ul style="list-style-type: none"> - Check to ensure venting is properly sealed. - If restriction is required see "restricting vertical vents" section.
Remote wall switch is in 'OFF' position; main burner comes on when gas knob is turned to 'ON' position.	Wall switch is mounted upside down.	<ul style="list-style-type: none"> - Reverse.
	Remote wall switch is grounding.	<ul style="list-style-type: none"> - Replace.
	Remote wall switch wire is grounding.	<ul style="list-style-type: none"> - Check for ground (short); repair ground or replace wire.
	Faulty valve.	<ul style="list-style-type: none"> - Replace.

11.0 troubleshooting (electronic - GDI3E / GDIG3 / GDIX3)

! WARNING

- Always light the pilot whether for the first time or if the gas supply has run out, with the glass door open or removed.
- Turn off gas and electrical power before servicing the appliance.
- Appliance may be hot. Do not service until appliance has cooled.
- Do not use abrasive cleaners

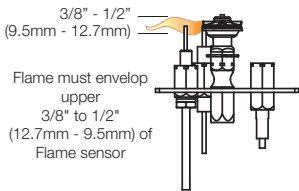
symptom	problem	test solution															
Main burner flame is a blue, lazy, transparent flame. (This is not applicable in outdoor appliances)	Blockage in vent.	- Remove blockage. In really cold conditions, ice buildup may occur on the terminal and should be removed as required. (To minimize this from reoccurring, the vent lengths that pass through unheated spaces (attics, garages, crawl spaces) should be wrapped with an insulated mylar sleeve).															
	Incorrect installation.	- Refer to "venting" section to ensure correct installation.															
Flames are consistently too large or too small. Carboning occurs.	Appliance is over-fired or under-fired.	- Check pressure readings: Inlet pressure can be checked by turning screw (A) counter-clockwise 2 or 3 turns and then placing pressure gauge tubing over the test point. Gauge should read as described on the chart below. Check that main burner is operating on 'HI'. Outlet pressure can be checked the same as above using screw (B). Gauge should read as described on the chart below. Check that main burner is operating on 'HI'. After taking pressure readings, be sure to turn screws clockwise firmly to reseal. DO NOT OVER TORQUE. Leak test with a soap and water solution.															
	 <p>3/8" - 1/2" (9.5mm - 12.7mm)</p> <p>Flame must envelop upper 3/8" to 1/2" (12.7mm - 9.5mm) of Flame sensor</p>	<table border="1"> <thead> <tr> <th>Pressure</th> <th>Natural Gas (inches)</th> <th>Natural Gas (millibars)</th> <th>Propane (inches)</th> <th>Propane (millibars)</th> </tr> </thead> <tbody> <tr> <td>Inlet</td> <td>*7" (minimum 4.5")</td> <td>17.4mb (minimum 11.2mb)</td> <td>13" (minimum 11")</td> <td>32.4mb (minimum 27.4mb)</td> </tr> <tr> <td>Outlet</td> <td>3.5"</td> <td>8.7mb</td> <td>10"</td> <td>24.9mb</td> </tr> </tbody> </table> <p style="text-align: center;">*Maximum inlet pressure not to exceed 13" w.c.</p>	Pressure	Natural Gas (inches)	Natural Gas (millibars)	Propane (inches)	Propane (millibars)	Inlet	*7" (minimum 4.5")	17.4mb (minimum 11.2mb)	13" (minimum 11")	32.4mb (minimum 27.4mb)	Outlet	3.5"	8.7mb	10"	24.9mb
Pressure	Natural Gas (inches)	Natural Gas (millibars)	Propane (inches)	Propane (millibars)													
Inlet	*7" (minimum 4.5")	17.4mb (minimum 11.2mb)	13" (minimum 11")	32.4mb (minimum 27.4mb)													
Outlet	3.5"	8.7mb	10"	24.9mb													
	Air shutter improperly adjusted.	- Return air shutter to specified opening, see "venturi adjustments" section in the installation manual.															
Carbon is being deposited on glass, logs, rocks, media, or combustion chamber surfaces.	Air shutter is blocked.	- Ensure air shutter opening is free of lint or other obstructions.															
	Flame is impinging on the glass, logs, rocks, media or combustion chamber.	- Ensure the media is positioned correctly in the appliance. - Open air shutter to increase the primary air. - Check the input rate: check the manifold pressure and orifice size as specified by the rating plate. - Ensure door gaskets are not broken or missing and the seal is tight. - Ensure vent liners are free of holes and well sealed at all joints. - Check that minimum rise per foot (meters) has been adhered to for any horizontal venting.															
White / grey film forms.	Sulphur from fuel is being deposited on glass, logs, or combustion chamber surfaces.	- Clean the glass with a recommended gas fireplace glass cleaner. DO NOT CLEAN GLASS WHEN HOT. - If deposits are not cleaned off regularly, the glass may become permanently marked.															
Exhaust fumes smelled in room, headaches.	Appliance is spilling. (This is not applicable in outdoor appliances).	- Check door seal.															
		- Check for exhaust damage. - Check that venting is installed correctly. - Room is in negative pressure; increase fresh air supply.															

troubleshooting (electronic - GDI3E / GDIG3 / GDIX3)

symptom	problem	test solution
Pilot will not light. Makes noise with no spark at pilot burner.	Wiring: short, loose, or damaged connections (poor flame rectification).	<ul style="list-style-type: none"> - Verify the thermocouple/sensor is clean and the wiring is undamaged. - Verify the interrupter block is not damaged or too tight. Verify connections from pilot assembly are tight; also verify the connections are not grounding out to any metal. (Remember, the flame carries the rectification current, not the gas. If flame lifts from pilot hood, the circuit is broken. A wrong orifice or too high of an inlet pressure can cause the pilot flame to lift)*. The sensor rod may need cleaning.
	No signal from remote with no pilot ignition.	<ul style="list-style-type: none"> - Reprogram receiver code. - Replace receiver.
	Poor grounding.	<ul style="list-style-type: none"> - Verify the valve / pilot assembly are properly grounded
	Improper switch wiring.	<ul style="list-style-type: none"> - Troubleshoot the system with the simplest on/off switch.
	Dirty, painted, or damaged pilot and/or dirty sensor rod.	<ul style="list-style-type: none"> - Clean sensor rod with a green Scotch-Brite™ pad to remove any contamination that may have accumulated. Verify continuity with multimeter with ohms set at the lowest range.
Pilot sparks but will not light.	Gas supply.	<ul style="list-style-type: none"> - Verify that the incoming gas line ball valve is "open". - Verify that the inlet pressure reading is within acceptable limits, inlet pressures must not exceed 13" W.C. (32.4mb).
	Out of propane gas.	<ul style="list-style-type: none"> - Fill the tank.
	Pilot supply line may contain air.	<ul style="list-style-type: none"> - Repeat ignition process several times or purge the pilot supply line.
	Incorrect wiring / grounding.	<ul style="list-style-type: none"> - Ensure correct polarity of wiring of thermocouple (if equipped). - Verify pilot assembly / valve are properly grounded.
	Receiver (if equipped).	<ul style="list-style-type: none"> - Reset program: hold reset button on receiver and wait for 2 beeps. Release after second beep. Press small flame button on remote within 20 seconds, you will hear an additional beep (this signals a successful reset). - Replace receiver.
	Valve.	<ul style="list-style-type: none"> - Check valve and replace if necessary (Do not to overtighten thermocouple).
Burner continues to spark and pilot lights but main burner does not light.	Short or loose connection in sensor rod.	<ul style="list-style-type: none"> - Verify all connections. Verify the connections from the pilot assembly are tight. Also, verify these connections are not grounding out to any metal.
	Dirty, painted, or damaged pilot assembly components.	<ul style="list-style-type: none"> - Clean using a green Scotch-Brite™ pad to remove any contamination that may have accumulated on the sensor rod, pilot hood, ignitor, or flame sensor. Verify continuity with multimeter with ohms set at the lowest range.
Remote wall switch is in "off" position; burner comes on.	Wall switch mounted upside down.	<ul style="list-style-type: none"> - Reverse.
	Remote wall switch and/or wire is grounding.	<ul style="list-style-type: none"> - Replace. - Check for ground (short); repair ground or replace wire.
	Faulty wire	<ul style="list-style-type: none"> - Replace.
Remote and / or receiver is not functioning properly.	Remote controls lights but no spark or flame. (Remote is locked out).	<ul style="list-style-type: none"> - Reset by turning power source off then on. <div style="border: 1px solid black; padding: 2px; margin-top: 5px;"> <p>note: If back up batteries are installed, they must also be removed to re-program</p> </div>
	Receiver or remote has low battery.	<ul style="list-style-type: none"> - Replace batteries.
	Appliance functions but does not respond to receiver / remote	<ul style="list-style-type: none"> - Ensure appliance is being operated by the same device that turned it on. Remote controls function if appliance was turned on by remote. Receiver controls function if appliance was turned on by receiver.
	Error with synchronizing.	<ul style="list-style-type: none"> - Reset receiver and remote.
	Remote too far away from receiver.	<ul style="list-style-type: none"> - Refer to "wiring diagram" section.
	Wire connector pins are bent.	<ul style="list-style-type: none"> - Straighten pins.
	Valve wiring is damaged.	<ul style="list-style-type: none"> - Replace valve.

symptom	problem	test solution
Lights or blower won't function (if equipped).	Control module switch in wrong position.	- Verify ON/OFF switch is in the "I" position which denotes on.
	COM switch is unplugged.	- Verify "COM" switch is plugged into the front of the control module.
Flames are very aggressive.	Door is ajar.	- Ensure door is secured properly.
	Venting action is too great.	- Check to ensure venting is properly sealed or restrict vent exit with restrictor plate. (Not available in all appliances).
Appliance won't perform any functions.	No power to the system.	- Check breaker to verify it's in the "on" position.
	Receiver switch in wrong position (if equipped).	- Verify that the 3 position switch on the receiver is in the remote position (middle).
	Transmitter isn't operational.	- Check battery power and battery orientation.

The following applies specifically to the SIT system only:

Pilot will not light. Makes no noise with no spark at pilot burner. (Lights and blower operate, if equipped).	Ignition box has been locked out.	Choose one of the 3 methods below to reset the system. <ol style="list-style-type: none"> 1. To reset ignition box when locked out. Turn off power supply and remove batteries (if used) from the back up battery pack. 2. To reset the DFC Board when the board goes into a lock out condition and the LED is blinking 3 times using the transmitter on/off button: <ul style="list-style-type: none"> Step 1: Turn the system off by pressing the on/off button to turn the system off. Step 2: After approximately 2 seconds press the on/off button on the transmitter again. The DFC Board will reset and the ignition sequence will start again. 3. To reset the DFC Board when the board goes into a lock out condition and the LED is blinking 3 times by cycling flame: <ul style="list-style-type: none"> Step 1: In the manual flame control mode, use the down arrow button to reduce the flame to off, indicated by the word OFF displayed on the transmitter LCD screen. Step 2: Wait approximately 2 seconds and press the up arrow button, the ignition sequence will start.
---	-----------------------------------	--

note:

Starting from **off**, press the **on** button on the transmitter. After approximately 4 seconds **on/off** button is pressed, the ignition board will start the spark. The attempt for ignition will last approximately 60 seconds. If there is no flame ignition (rectification), the board will stop sparking and the board will go into lock out.

12.0 warranty

Napoleon products are manufactured under the strict Standard of the world recognized ISO 9001 : 2015 Quality Management System.

Napoleon products are designed with superior components and materials assembled by trained craftsmen who take great pride in their work. The burner and valve assembly are leak and test-fired at a quality test station. The complete appliance is again thoroughly inspected by a qualified technician before packaging to ensure that you, the customer, receive the quality product that you expect from Napoleon.

Napoleon Gas Appliance President's Lifetime Limited Warranty

The following materials and workmanship in your new Napoleon gas appliance are warranted against defects for as long as you own the appliance. This covers: combustion chamber, heat exchanger, stainless / steel burner, Phazer™ logs and embers, rocks, ceramic glass (thermal breakage only), gold plated parts against tarnishing, porcelainized enameled components and aluminum extrusion trims.*

Electrical (110V and millivolt) components and wearable parts are covered and Napoleon will provide replacement parts free of charge during the first year of the limited warranty. This covers: blowers, gas valves, thermal switches, switches, wiring, remote controls, ignitors, gaskets and pilot assemblies.*

Labour related to warranty repair is covered free of charge during the first year (labour warranty is not applicable for the Gas Log Sets). Repair work, however, requires the prior approval of an authorized company official. Labour costs to the account of Napoleon are based on a predetermined rate schedule and any repair work must be done through an authorized Napoleon dealer.

* Construction of models vary. Warranty applies only to components included with your specific appliance.

Conditions and Limitations

Napoleon warrants its products against manufacturing defects to the original purchaser only. Registering your warranty is not necessary. Simply provide your proof of purchase along with the model and serial number to make a warranty claim. Napoleon reserves the right to have its representative inspect any product or part thereof prior to honouring any warranty claim. Provided that the purchase was made through an authorized Napoleon dealer your appliance is subject to the following conditions and limitations:

Warranty coverage begins on the date of original installation. This factory warranty is non-transferable and may not be extended whatsoever by any of our representatives. The gas appliance must be installed by a licensed, authorized service technician or contractor qualified and authorized installer, service agency or supplier. Installation must be done in accordance with the installation instructions included with the product and all local and national building and fire codes. This limited warranty does not cover damages caused by misuse, lack of maintenance, accident, alterations, abuse or neglect, and parts installed from other manufacturers will nullify this warranty. This limited warranty further does not cover any scratches, dents, corrosion or discoloring caused by excessive heat, abrasive and chemical cleaners nor chipping on porcelain enamel parts, mechanical breakage of Phazer™ logs and embers. This warranty extends to the repair or replacement of warranted parts which are defective in material or workmanship provided that the product has been operated in accordance with the operation instructions and under normal conditions. After the first year, with respect to this President's Lifetime Limited Warranty, Napoleon may, at its discretion, fully discharge all obligations with respect to this warranty by refunding to the original warranted purchaser the wholesale price of any warranted but defective part(s).

After the first year, Napoleon will not be responsible for installation, labour, or any other expenses related to the reinstallation of a warranted part and such expenses are not covered by this warranty. Notwithstanding any provisions contained in the President's Lifetime Limited Warranty, Napoleon's responsibility under this warranty is defined as above and it shall not in any event extend to any incidental, consequential or indirect damages. This warranty defines the obligations and liability of Napoleon with respect to the Napoleon gas appliance and any other warranties expressed or implied with respect to this product, its components or accessories are excluded. Napoleon neither assumes, nor authorizes any third party to assume, on its behalf, any other liabilities with respect to the sale of this product. Napoleon will not be responsible for: over-firing, downdrafts, spillage caused by environmental conditions such as rooftops, buildings, nearby trees, hills, mountains, inadequate vents or ventilation, excessive venting configurations, insufficient makeup air, or negative air pressures which may or may not be caused by mechanical systems such as exhaust fans, furnaces, clothes dryers, etc. Any damages to the appliance, combustion chamber, heat exchanger, plated trim or other components due to water, weather damage, long periods of dampness, condensation, damaging chemicals or cleaners will not be the responsibility of Napoleon.

During the first 10 years Napoleon will replace or repair the defective parts covered by the lifetime warranty at our discretion free of charge. From 10 years to life, Napoleon will provide replacement parts at 50% of the current retail price. The manufacturer may require that defective parts or products be returned or that digital pictures be provided to support the claim. Returned products are to be shipped prepaid to the manufacturer for investigation. If a product is found to be defective, the manufacturer will repair or replace such defect. Before shipping your appliance or defective components, your dealer must obtain an authorization number. Any merchandise shipped without authorization will be refused and returned to sender. Shipping costs are not covered under this warranty. Additional service fees may apply if you are seeking warranty service from a dealer. Warranty labour allowance is only for the replacement of the warranted part. Travel, diagnostic tests, shipping and other related charges are not covered by this warranty.

All specifications and designed are subject to change without prior notice due to on-going product improvements. Napoleon is a registered trademark of Wolf Steel Ltd.

NAPOLEON CELEBRATING OVER 40 YEARS OF HOME COMFORT PRODUCTS



7200, Route Transcanadienne, Montréal, Québec H4T 1A3
24 Napoleon Road, Barrie, Ontario, Canada L4M 0G8
214 Bayview Drive, Barrie, Ontario, Canada L4N 4Y8
103 Miller Drive, Crittenden, Kentucky, USA 41030
De Riemsdijk 22, 4004 LC Tiel, The Netherlands

Phone: 1-866-820-8686
napoleon.com