

# Installation Instructions

Gas Fired Direct Vent Room Heater Inserts Listed Certified for USA. and Canada



Model Numbers:

**IDV26** — Stock Numbers: IDV26N, IDV26NE, IDV26NE2, IDV26LP, IDV26LPE, IDV26LPE2

Minimum Fireplace Opening Required: 33"W x 19-1/2"H x 14-1/4"D Components In  
28"W x 19-1/2"H x 14-1/4"D Components Out

Are Certified to: CSA/ANSI Z21.88-17 • CSA 2.33-17, CSA 2.17-2017



## **⚠ WARNING:**

### **FIRE OR EXPLOSION HAZARD**

Failure to follow safety warnings exactly could result in serious injury, death, or property damage.

- Do not store or use gasoline or other flammable vapors and liquids in the vicinity of this or any other appliance.
- **WHAT TO DO IF YOU SMELL GAS**
  - Do not try to light any appliance.
  - Do not touch any electrical switch; do not use any phone in your building.
  - Leave the building immediately.
  - Immediately call your gas supplier from a neighbor's phone. Follow the gas supplier's instructions.
  - If you cannot reach your gas supplier, call the fire department.
- Installation and service must be performed by a qualified installer, service agency or the gas supplier.

This appliance may be installed in an aftermarket, permanently located, manufactured home (USA only) or mobile home, where not prohibited by local codes.

This appliance is only for use with the type of gas indicated on the rating plate. This appliance is not convertible for use with other gases, unless a certified kit is used.

**⚠ WARNING:** The IDV26 Fireplace Insert was designed for installation in a solid fuel fireplace that has been installed in accordance with national, provincial/state and local building codes and is constructed of noncombustible materials. Do not remove any refractory materials from any masonry solid fuel fireplace.

The IDV26 Fireplace Insert was designed for installation in a zero clearance type listed solid fuel burning factory built fireplace. It may be necessary to remove the damper plate, refractory liners, log grates, glass door, and screen rails/mesh. Removal of the smoke baffle is necessary in most cases.

## **⚠ DANGER**



**HOT GLASS WILL CAUSE BURNS.  
DO NOT TOUCH GLASS UNTIL COOLED.  
NEVER ALLOW CHILDREN TO TOUCH GLASS.**

A barrier designed to reduce the risk of burns from the hot viewing glass is provided with this appliance and must be installed for the protection of children and other at-risk individuals.

If the barrier becomes damaged, the barrier must be replaced with the manufacturer's barrier for this appliance.

**INSTALLER:** Leave this manual with the appliance.

**CONSUMER:** Retain this manual for future reference.



A Division of R-Co. Inc.  
2340 Logan Avenue  
Winnipeg, Manitoba, Canada R2R 2V3  
Ph: (204) 632-1962  
Printed in Canada November 8, 2022  
Part # 26IDV-MAN17

## Table of Contents

Table of Contents.....	2-3
Pre-installation Questions and Answers / Operating and Maintenance Instructions.....	4
Safety Screen Installation.....	5
Using Steel Studs and Concrete Board.....	6
Fireplace Installations in Covered Outdoor Locations.....	7
Mobile Home/Manufactured Housing Installation.....	8
Warnings, Installations and Operations / Massachusetts Requirements.....	9-10
Important Information / Glass Safety.....	11
IDV26 Insert Dimensions and Sizing.....	12
Top View Dimensions - Components In / Components Out.....	13
I26CV Clean Views and Surround Sizes.....	14
I26SU Universal Surround.....	15-16
Clean View and Surround Attachment.....	17
I26S1 / I26SPF1 / I26SU Surround Installation.....	18
I26CV2 / I26CVPF2 Wide Clean View Installation – Components In (As Shipped).....	19
I26CV2 / I26CVPF2 Wide Clean View Installation -Components Out.....	20
IDV26PRL Porcelain Liner Panels.....	21
IDV26RL Brick Liner Panels.....	22
IDV26 <b>-Millivolt-</b> Control Components Outside the Opening- COMPONENTS OUT.....	23-24
IDV26 <b>-IPI-</b> Control Components Outside the Opening- COMPONENTS OUT.....	24-25
IDV26 Fan Speed Control Outside COMPONENTS OUT.....	26
IDV26 Fan Removal / Installation / Wiring.....	27-28
IDV26 Remote Receiver Location.....	29
MQLOGF26.....	30
LOGF27.....	31
Burner Installation/Removal.....	32
Clearance to Combustible Mantels.....	33
Wall Coverings.....	34
Mantel Clearance Shield – I33CS.....	35-36
Leveling Instructions / Riser Kit Installation.....	37
Glass Door Information.....	38
MQRSP4 and MQRSP8.....	39
MQROCK2 / MQROCK3.....	40-41
MQStone with MQRSP8.....	42
MQ Ember with MQRSP8 or RSP10.....	43
RSP10 Glass Support Platform.....	44
<b>- Gas Section -</b>	
Lighting Instructions –Millivolt.....	45
Troubleshooting the Gas Control System.....	46
Gas Line Installation.....	47
Annual Inspection List for Determining Safe Operation of a Direct Vent Gas Fireplace.....	48
Burner System Maintenance.....	49
Conversion Kit Instructions – PART A.....	50

Gas Conversion for Top Convertible Pilot – Part B (series 0190XYZ).....	51
Gas Conversion for Modulator – PART C.....	52
Remote Control Operation.....	53
<b>- Proflame 1-</b>	
IPI Electronic Ignition System.....	54-55
IPI Electronic Ignition Parts List – Standard System.....	56
IPI Configurations 1 & 2 .....	57
Operating the Receiver Without Batteries For GT / EGT / GTM / EGTM Remote Controls.....	58
Electronic Ignition Lighting Instructions.....	59
<b>-Proflame 2-</b>	
Proflame 2 Parts List, GTMFL Configuration.....	60
Proflame 2 Remote Control.....	61
Cold Climates – CPI Setting - Proflame 2 Remote Control.....	62
Remote Flame Control, Room Thermostat Operation.....	63
Smart Thermostat, Fan Speed Control.....	64
Schematic.....	65
<b>-Venting-</b>	
IDVVT / IDVVT43 Venting Installation.....	66
Installation of Vent Pipe.....	67
Insulation of Chimney Cavity.....	68
Proflame 1 Appliances - Cold Climate Mode.....	68
<b>-Parts List-</b>	
IDV26 Parts List.....	69
Parts and Venting for IDV26/ IDV33/ IDV43.....	70
Limited Lifetime Warranty.....	71

## Pre-installation Questions and Answers

### About curing of the paint

Your stove or fireplace has been painted with the highest quality silicone stove paint. This paint dries quickly in 15-20 minutes when first applied at the factory. However, due to the high temperature silicone components, the paint will cure when heat is applied to the appliance as it is first used. The following information applies to the curing process to get the paint fully hard and durable.

Fire the appliance four successive times for 10 minutes each firing and a 5 minute cool down between each. Be aware during log and firebox paint curing that a white deposit may be developing on the inside of the glass doors. It is important to remove this white deposit from the glass doors using a fireplace glass cleaner.

- Babies, small children, pregnant women and pets should leave the area during the cure phase.
- Ventilate well, open doors and windows.
- Do not touch during curing.

### Why does my fireplace or stove give off odor?

It is normal for your fireplace to give off some odor at first. This is due to the curing of the paint, adhesives, silicones and any undetected oil from the manufacturing process as well as the finishing materials used with the installations (e.g. marble, tile and the adhesives used to adhere this product to the walls can react with heat and cause odors).

It is recommended that you burn your gas fireplace or stove for a minimum of four hours at a time with the fan off (if a fan is present) after the curing of the paint has been completed. These odors can last upward to 40 hours of burn time; keep burning at a minimum of four hours per use until odors dissipate.

### Noise coming from the fireplace?

Noise is caused by the expansion and contraction of metal as the appliance heats up and cools down. This is normal and is similar to the sounds produced by a furnace or heating duct. This noise does not affect the operation or longevity of your fireplace.

It is also normal for the fan to make some noise when it comes on. This noise can be reduced somewhat by turning down the speed of the fan with the variable speed control. Be aware, however, that this will reduce the volume of heated air circulated into the room by the fan.

### Note to the Installer:

Be sure appliance is working properly and its operation (including remote control operation, if included) is fully explained to and understood by the customer.

## Operations and Maintenance Instructions

For safe installation and operation note the following:

- Be sure to read and understand all the instructions in this manual before operation of appliance.
- Ensure all wiring is correct and properly enclosed to prevent possible shock.
- Check for gas leaks.
- Make sure the glass door is properly installed before operation. Never operate the appliance with the glass door removed.
- Make sure venting and termination cap are installed and unobstructed.
- If brick or porcelain liners are used, ensure they are installed.
- Verify that the pilot can be seen when lighting the appliance. If not, the log or rock placement is incorrect.
- If the unit is turned off, you must wait a minimum of 60 seconds before re-lighting it.
- Venting systems should be periodically examined by a qualified agency.
- The flow of combustion and ventilation air must not be obstructed.
- The Burner/Log Assembly has been engineered and permanently adjusted for proper flame control.
- Periodically remove the logs from the grate assembly and vacuum any loose particles from the grate and burner areas. See Log Placement page to remove logs. Vacuum burner parts and replace logs.
- Never use your gas fireplace as a cooking device.
- Label all wires prior to disconnection when servicing controls. Wiring errors can cause improper and dangerous operation. Verify proper operation after servicing.
- Areas in and around the Chase Vent Openings should be cleaned annually.



## Safety Screen Installation- IDV26, IDV33 / IDV43

### Contents of Kit:

[1] Safety Screen

**NOTE:** Screens are symmetrical from top to bottom.

### **⚠WARNING:**

Wait until unit is **COMPLETELY** cool before touching glass or attempting to install or remove Child Safety Screens.

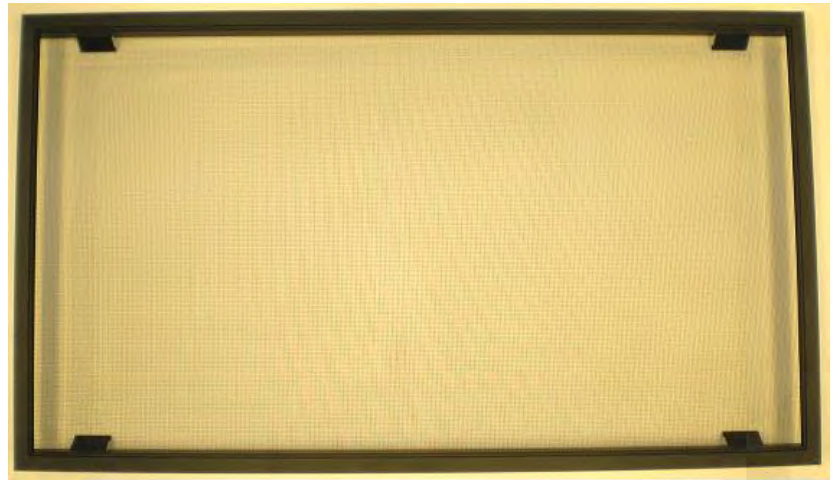

Screen with Horizontal Angles

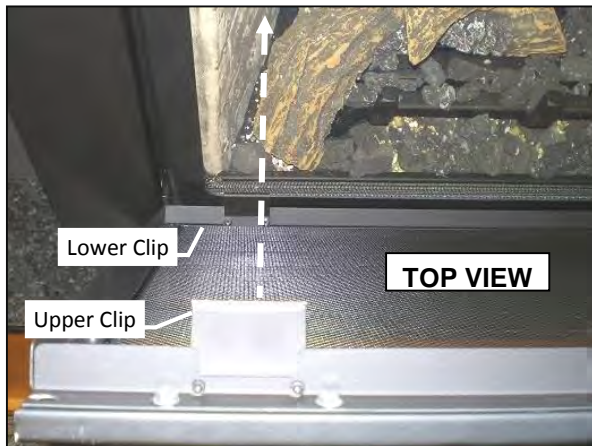

Hook Lower Clip onto glass door frame.



Press down and push upper clip under top glass door frame.

### To install screens

hook bottom clip onto glass door frame, then press down and push upper clip under top glass door frame, then release. Clip will hook onto frame.

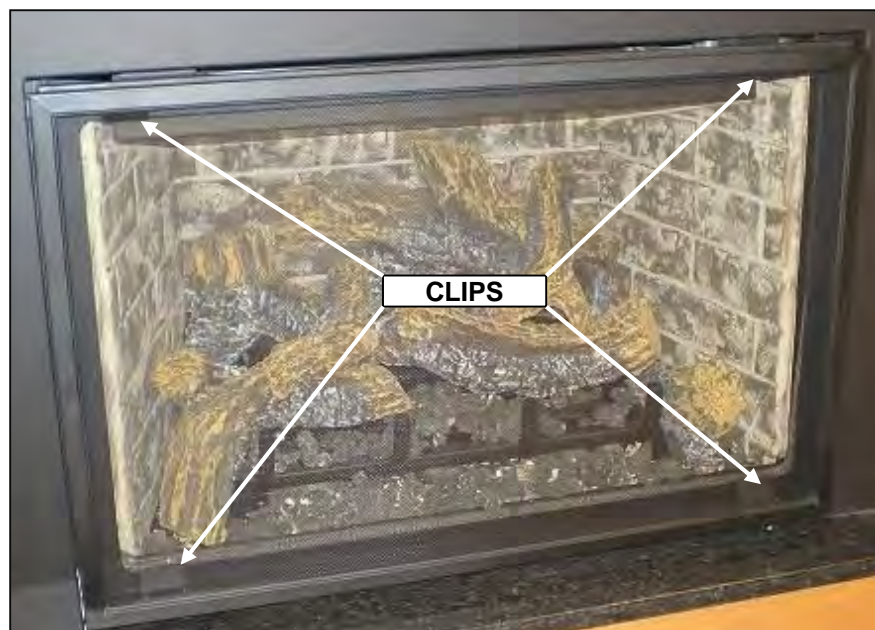

Fireplace with screen.

### To remove Safety Screens **WAIT UNTIL FIREPLACE IS COMPLETELY COOL.**

Press down on upper clips and remove screen from fireplace glass door.

## Installation of IDV26 / IDV33 / IDV43 Using Steel Studs and Concrete Board over Wood Burning Fireplace

Brick facing may be removed and replaced with non-combustible materials such as steel studs and concrete board. The opening between the firebox and non-combustive materials must be sealed so as the heat cannot run between the face of the wood fireplace and the re-facing materials.

Insert must be pulled out so the appliance is flush with the finishing materials and the clean view kit is proud of the finished non-combustible enclosure (wood burning fireplace).

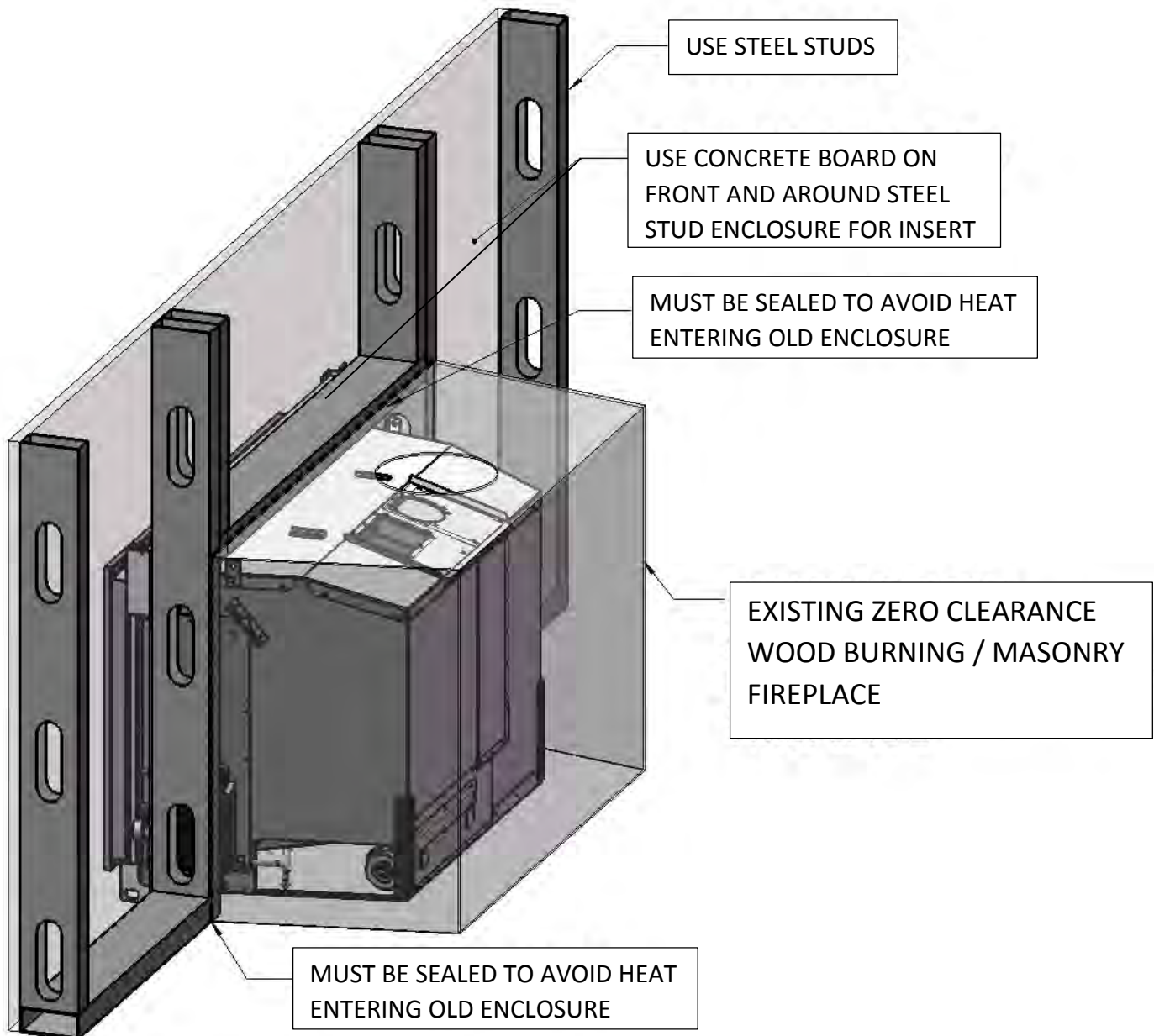

## Fireplace Installations in Covered Outdoor Locations – FOR BASIC MILLIVOLT UNITS ONLY- NO FAN – NO LIGHTS-

**CAUTION** – Installation of an indoor gas fireplace with an outdoor exposure is not covered under the (ANSI Z21.88 – CSA 2.22 or ANSI Z21.50 – CSA 2.33) standard(s) used to certify the indoor gas-fired fireplace. The Intertek safety certification will not apply to this installation method. This installation method must be deemed acceptable by the Authority Having Jurisdiction (AHJ) prior to the indoor gas fireplace being installed.

Kingsman and Marquis Direct Vent fireplaces may be installed into outdoor locations provided they are suitably protected from direct water impingement. However, all installation clearances in the appliance manual must be observed. Framing, Clearances to Combustibles, Mantel Heights, Facing Requirements, Venting Installation, etc. **Use supplied Safety Screen.**

- All wiring connections to line power shall be in accordance with outdoor requirements of; -NECA NFPA 70 in the USA -Canadian Electrical Code, CSA C22.1 for Canada.
- The Fireplace is not to be operated in temperatures below freezing (0°C / 32°F).
- **⚠ NOTE: TEMPERED GLASS WARNING:** Tempered glass is vulnerable to rapid and/or extreme changes in temperature (thermal shock). Take care to prevent water from contacting the fireplace, especially if it is hot.
- See-Through Units are suitable for an outdoor location, but not on the outside wall of a house or other structure, as air flows through both sides of the fireplace.
- A Minimum sheltering cover (overhang) of 1/2 the distance from the base of the fireplace to the ceiling (base of roofline) is required.

**EXAMPLE:** The bottom of the fireplace is 84" from the ceiling. Therefore, 42" of sheltering cover is required above fireplace.

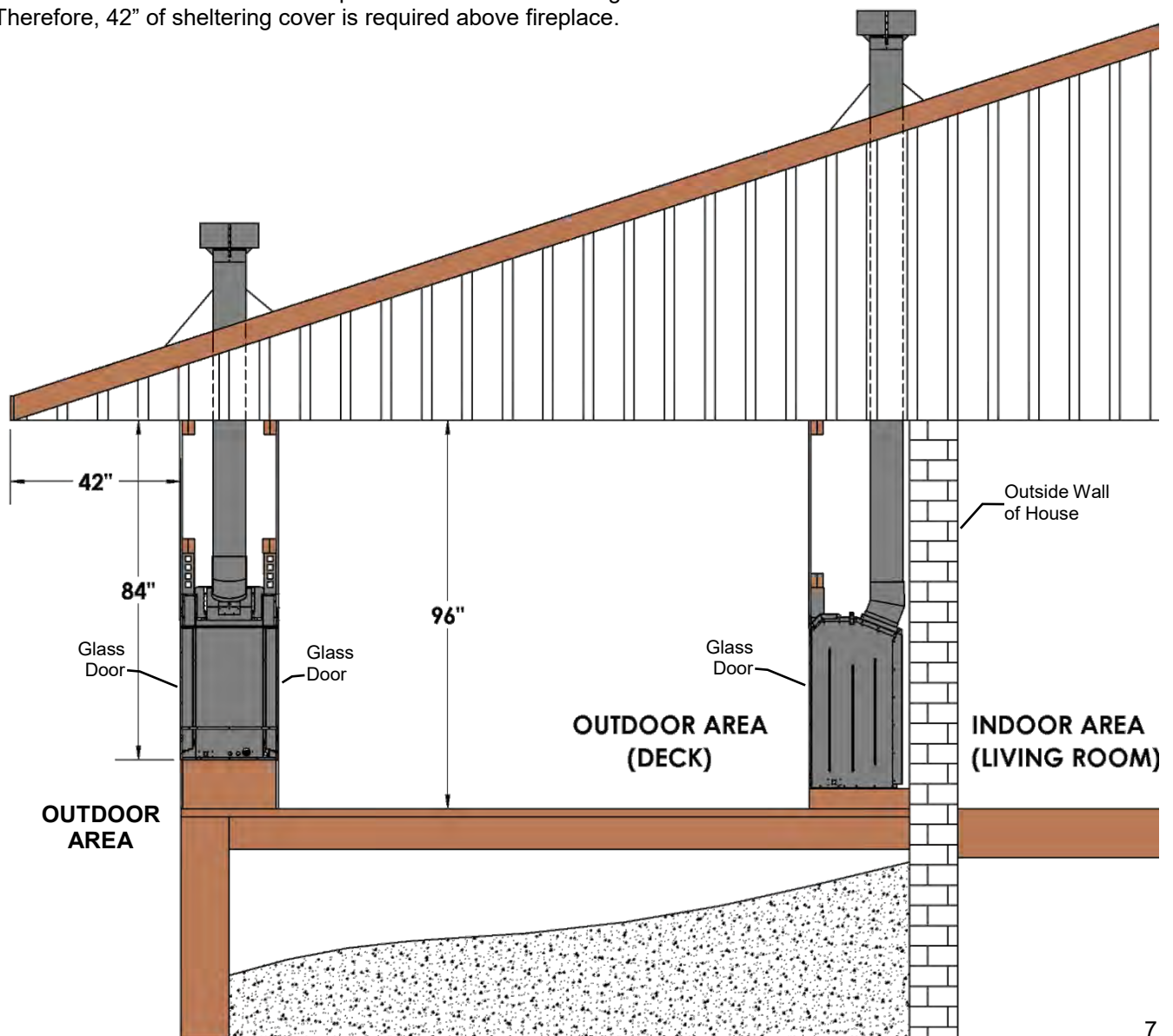

## Mobile Home/Manufactured Housing Installation

This Direct Vent System Appliance must be installed in accordance with the manufacturer's installation instructions and the Manufactured Home Construction and Safety Standard Title 24 CFR, Part 3280, or the current Standard for Fire Safety Criteria for Manufactured Home Installation, Sites, and Communities ANSI/NFPA 501A, and with CAN/CSA Z240 MH Mobile Home Standard in Canada.

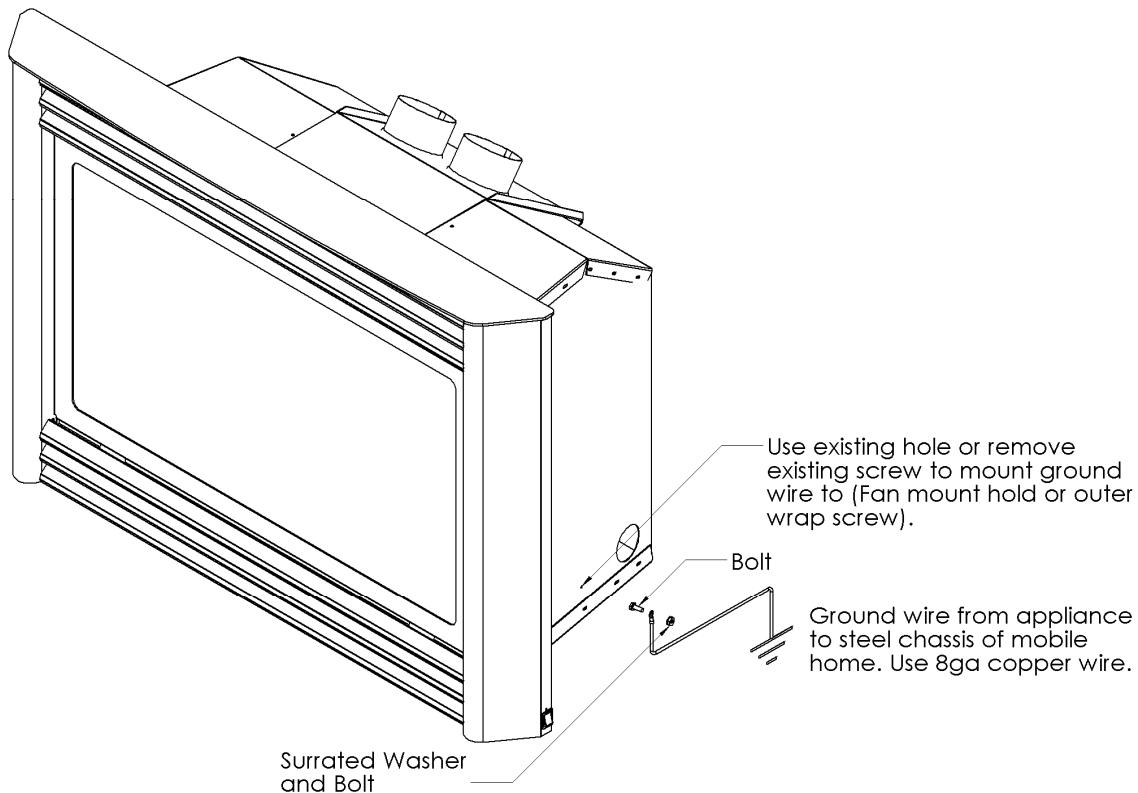

### **THIS APPLIANCE MAY BE INSTALLED IN MANUFACTURED (MOBILE) HOMES AFTER FIRST SALE.**

Please follow the current ANSI/NFPA 70 National Electrical Code in the USA and CAN/CSA C22.1 Canadian National Electrical Code in Canada.

An appliance must be grounded to the steel chassis of the home with 8ga. copper wire using a serrated or star washer to penetrate paint or protective coating to insure grounding.

Use carriage bolt at the attachment point (see diagram above) to secure the appliance to the floor.

Bedroom approved.



**Warning: Do not compromise the structural integrity of the manufactured home wall, floor or ceiling, during installation of appliance or venting.**

*For required venting components see venting installation in appropriate section of this manual.*



## Warnings, Installations and Operations - Installation Regulations

This gas appliance must be installed by a qualified installer in accordance with local building codes, or in the absence of local codes, with the current CAN/CSA-B149.1 or .2 Installation Code (in Canada) or the current National Fuel Gas Code Z223.1- NFPA 54 when installed in the United States.

This appliance, when installed, must be electrically connected and grounded in accordance with local codes, or in the absence of local codes, with the current CSA C22.1 Canadian Electrical Code or with the National Electrical Code; ANSI/NFPA 70 when installed in the United States.



**FOR SAFE INSTALLATION AND OPERATION OF YOUR GAS FIREPLACE PLEASE NOTE THE FOLLOWING:**

1. Do not clean when the glass is hot.
2. Do not use abrasive cleaners.
3. Using a substitute glass will void all product warranties.
4. For safe operation, glass doors must be closed.
5. When purging the gas line, the glass front must be removed.
6. Do not strike or abuse glass. Take care to avoid breakage.
7. Do not alter gas orifice.
8. No substitute materials may be used other than factory supplied components.
9. This appliance gives off high temperatures and should be located out of heavy traffic areas and away from furniture and draperies.
10. Children and adults should be alerted to the hazards of the high surface temperatures of this appliance and should stay away to avoid burns or ignition of clothing.
11. Young children should be carefully supervised when they are in the same room as the appliance. Toddlers, young children and others may be susceptible to accidental contact burns. A physical barrier is recommended if there are at risk individuals in the house. To restrict access to a fireplace or stove, install an adjustable safety gate to keep toddlers, young children and other at risk individuals out of the room and away from hot surfaces.
12. Under no circumstances should any solid fuels (wood, paper) be used in this appliance.
13. Under no circumstances should this appliance be modified. Any parts that have to be removed for servicing should be replaced prior to operating this appliance.
14. Any safety screen, guard, or barrier removed for servicing an appliance must be replaced prior to operating the appliance.
15. Installation and repair should be done by a qualified service person. The appliance should be inspected before use and at least annually by a professional service person. More frequent cleaning may be required due to excessive lint from carpeting, bedding material, et cetera. It is imperative that control compartments, burners and circulating air passageways of the appliance be kept clean. Make sure that the gas valve and pilot light are turned off before you attempt to clean this unit.
16. Clothing or other flammable material should not be placed on or near the appliance. This appliance should not be used as a drying rack for clothing nor should Christmas stockings or decorations be hung from it.
17. Do not use this heater if any part has been under water. Immediately call a qualified service technician to inspect the heater and to replace any part of the control system and any gas control which has been under water.
18. Do not operate appliance unless completely installed as per installation instructions.
19. Failure to position the parts in accordance with these diagrams or failure to use only parts specifically approved with this appliance may result in property damage or personal injury.
20. **WARNING: Do not operate appliance with the glass front removed, cracked or broken. Replacement of the glass should be done by a licensed or qualified service person.**
21. The appliance area must be kept clear and free from combustible materials, gasoline, and other flammable vapors and liquids.
22. The front of the fireplace gives off high temperatures that could ignite combustible material which is kept close to the front of the unit.
23. Ensure that power to the Fireplace is turned off before servicing.
24. Do not operate this Fireplace without the glass front or with a broken glass.
25. Improper installation, adjustment, alteration, service or maintenance can cause injury or property damage. Refer to the owner's information manual provided with this appliance. For assistance or additional information consult a qualified installer, service agency, or the gas supplier.
26. Operation of this appliance when not connected to a properly installed and maintained venting system or tampering with the blocked vent shutoff system can result in carbon monoxide (CO) poisoning and possible death.
27. This appliance is equipped with a three-prong (grounding) plug for your protection against shock hazard and should be plugged directly into a properly grounded three-prong receptacle. Do not cut or remove the grounding prong from this plug.
28. **NOT INTENDED FOR USE AS A PRIMARY HEAT SOURCE.** This appliance is tested and approved as either supplemental room heat or as a decorative appliance. It should not be factored as primary heat in residential heating calculations.
29. This appliance must not be connected to a chimney flue serving a separate solid-fuel burning appliance.

## Installation Requirements for the Commonwealth of Massachusetts

In the Commonwealth of Massachusetts, the installer or service agent shall be a plumber or gas fitter licensed by the Commonwealth.

When installed in the Commonwealth of Massachusetts or where applicable codes; the unit shall be installed with a CO detector per the requirements listed below.

1. For direct-vent appliances, mechanical-vent heating appliances or domestic hot water equipment, where the bottom of the vent terminal and the air intake is installed below four feet above grade the following requirements must be satisfied:
  - A. If there is not one already present, on each floor level where there are bedroom(s), a carbon monoxide detector and alarm shall be placed in the living area outside the bedroom(s). The carbon monoxide detector shall comply with NFPA 720.
  - B. A carbon monoxide detector shall be located in the room that houses the appliance or equipment and shall:
    - Be powered by the same electrical circuit as the appliance or equipment such that only one service switch services both the appliance and the carbon monoxide detector;
    - Have battery back-up power;
    - Meet ANSI./UL 2034 Standards and comply with NFPA 720; and
    - Have been approved and listed by a Nationally Recognized Testing Laboratory as recognized under 527 CMR.
  - C. A Product-approved vent terminal must be used, and if applicable, a Product-approved air intake must be used. Installation shall be in strict compliance with the manufacturer's instructions. A copy of the installation instructions shall remain with the appliance or equipment at the completion of the installation.
  - D. A metal or plastic identification plate shall be mounted at the exterior of the building, four feet directly above the location of vent terminal. The plate shall be of sufficient size to be easily read from a distance of eight feet away, and read "Gas Vent Directly Below".
2. For direct-vent appliances, mechanical-vent heating appliances or domestic hot water equipment where the bottom of the vent terminal and the air intake is installed above four feet above grade the following requirements must be satisfied:
  - A. If there is not one already present, on each floor level where there are bedroom(s), a carbon monoxide detector and alarm shall be placed in the living area outside the bedroom(s). The carbon monoxide detector shall comply with NFPA 720.
  - B. A carbon monoxide detector shall:
    - Be located in the room that houses the appliance or equipment;
    - Be either hard-wired or battery powered or both; and
    - Shall comply with NFPA 720.

A Product-approved vent terminal must be used, and if applicable, a Product-approved air intake must be used. Installation shall be in strict compliance with the manufacturer instructions. A copy of the installation instructions shall remain with the appliance or equipment at the completion of the installation.

For the state of Massachusetts a **T-handle gas shut-off valve** must be used on a gas appliance. This T-handle gas shut-off valve must be listed and approved by the state of Massachusetts. This is in reference to the state of Massachusetts state code CMR238.

## Carbon Monoxide (CO) Detector

NOTE: It is recommended that a Carbon Monoxide (CO) Detector be installed in or near bedrooms and on all levels of your home. Place a detector about 15ft [4.5m] outside the room that houses your gas appliance.

Certified for installation in a bedroom or bed/sitting room. In Canada must be installed with listed millivolt thermostat. In USA see local codes.

## Important Information

### INSTALLATIONS

- The following label (supplied with the gas fireplace insert) must be attached with rivets or screws to the inside of the firebox of the fireplace into which it is installed:
- Cutting any sheet-metal parts of the fireplace, in which the gas fireplace insert is to be installed, is prohibited.
- If the factory-built fireplace has no gas access hole(s) provided, an access hole of 1.5 in (37.5 mm) or less may be drilled through the lower sides or bottom of the firebox in a proper workmanship like manner. This access hole must be plugged with non-combustible insulation after the gas supply line has been installed.
- The fireplace flue damper can be fully blocked open or removed for installation of the gas fireplace insert.
- Ensure that existing chimney cleanouts fit properly.
- refractory, glass doors, screen rails, screen mesh and log grates can be removed from the fireplace before installing the gas fireplace insert.
- Smoke shelves, shields and baffles may be removed if attached by mechanical fasteners.
- Trim panels or surrounds must not seal ventilation openings in the fireplace.
- The fireplace and fireplace chimney must be clean and in good working order and constructed of non-combustible materials.

**WARNING:** THIS FIREPLACE HAS BEEN CONVERTED FOR USE WITH A GAS FIREPLACE INSERT ONLY AND CANNOT BE USED FOR BURNING WOOD OR SOLID FUELS UNLESS ALL ORIGINAL PARTS HAVE BEEN REPLACED AND THE FIREPLACE RE-APPROVED BY THE AUTHORITY HAVING JURISDICTION. (PLEASE APPLY THIS TO THE FIREPLACE THAT THE INSERT IS BEING INSTALLED INTO)

**AVERTISSEMENT:** CETTE CHEMINÉE A ÉTÉ CONVERTIE UNIQUEMENT POUR ÊTRE UTILISÉE AVEC UN ENCASTREMENT POUR CHEMINÉE AU GAZ ET NE PEUT PAS ÊTRE UTILISÉE POUR BRÛLER DU BOIS OU DES COMBUSTIBLES SOLIDES À MOINS QUE TOUTES LES PIÈCES D'ORIGINE AIENT ÉTÉ REMPLACÉES ET QUE LA CHEMINÉE AIT ÉTÉ RÉAPPROUVÉE PAR LES AUTORITÉS AYANT JURISDICTION. (APPLIQUEZ CELA SVP À LA CHEMINÉE DONT L'ENCASTREMENT EST EN TRAIN D'Y ÊTRE INSTALLÉE)

PART #331DV-LABWARN

### MAINTENANCE

- If for any reason the vent air intake system is disassembled, re-install and re-seal per the instructions provided for the initial installation. See "Installation of Vent Pipe" section.
- It is recommended to annually inspect and clean the Burner System to prevent malfunction and / or sooting. This operation should be performed by your dealer or a qualified technician. Refer to Burner System Maintenance section.
- Venting systems should be periodically examined by a qualified agency.
- Periodically remove the logs from the grate assembly and vacuum any loose particles from the grate and burner areas. See Log Placement page to remove logs. Vacuum burner parts and replace logs.

## -Glass Safety- All Units

### IT IS THE RESPONSIBILITY OF THE HOME OWNER TO ENSURE THAT NO ONE TOUCHES A HOT APPLIANCE.

If the barrier becomes damaged, the barrier shall be replaced with the manufacturer's barrier for this appliance.

Any safety screen, guard, or barrier removed for servicing the appliance, must be replaced prior to operating the appliance.

- Children and adults should be alerted to the hazards of the high surface temperatures of this appliance and should stay away to avoid burns or ignition of clothing.
- Do not clean when the glass is hot.
- Young children should be carefully supervised when they are in the same room as the appliance. Toddlers, young children and others may be susceptible to accidental contact burns.
- A physical barrier is recommended if there are at risk individuals in the house. To restrict access to a fireplace or stove, install an adjustable safety gate to keep toddlers, young children and other at risk individuals out of the room and away from hot surfaces.
- Do not leave the fireplace remote control where it is accessible to children.



**! DANGER**

**HOT GLASS WILL CAUSE BURNS.**

**DO NOT TOUCH GLASS UNTIL COOLED.**

**NEVER ALLOW CHILDREN TO TOUCH GLASS.**

A barrier designed to reduce the risk of burns from the hot viewing glass is provided with this appliance and shall be installed for the protection of children and other at-risk individuals.

## IDV26 Insert Dimensions and Sizing

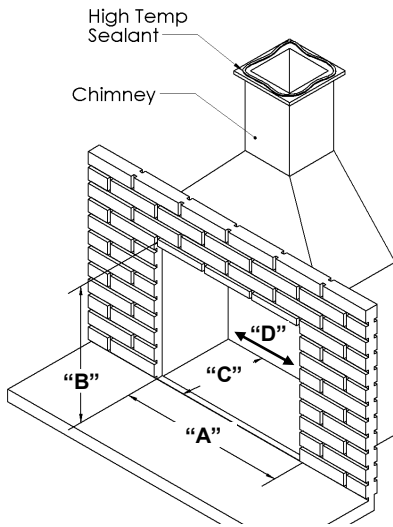

Minimum Opening Dimensions		
Dimension	Components In	Components Out
"A" Front Width:	33" Centered in existing fireplace *31" Not Centered in existing fireplace	28"
"B" Height:	19-1/2"	19-1/2"
"C" Depth:	14-1/4"	14-1/4"
"D" Back Width:	22"	22"

**Note:** Valve Control Components can be placed either inside the opening (**Components In**) or outside the opening (**Components Out**).

Units are shipped with Control Components in.

For instructions on changing to Components Out refer to **Control Components Outside the Opening- COMPONENTS OUT**.

### Base Model IDV26

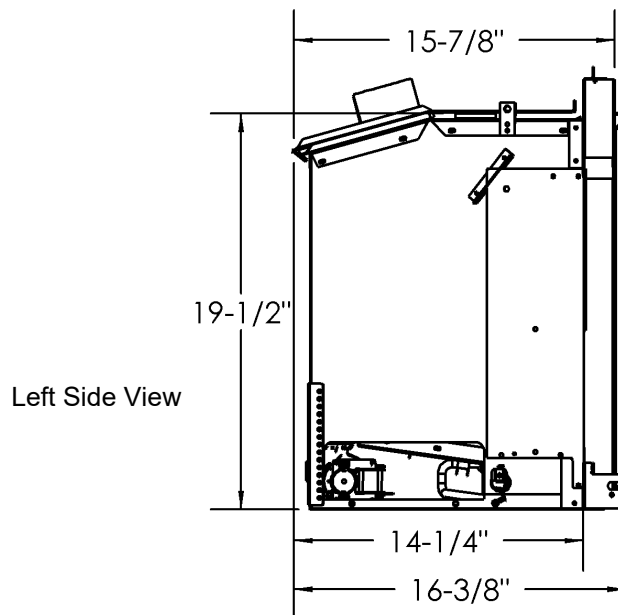
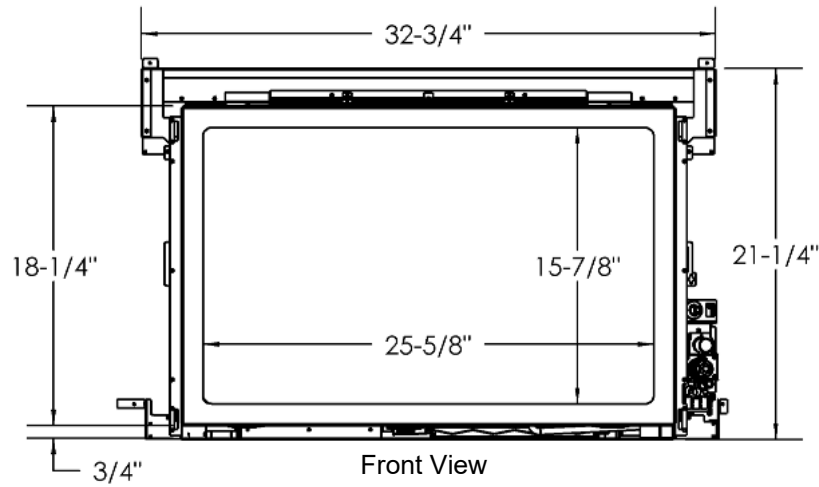



Top View Dimensions

Components In

Components Out

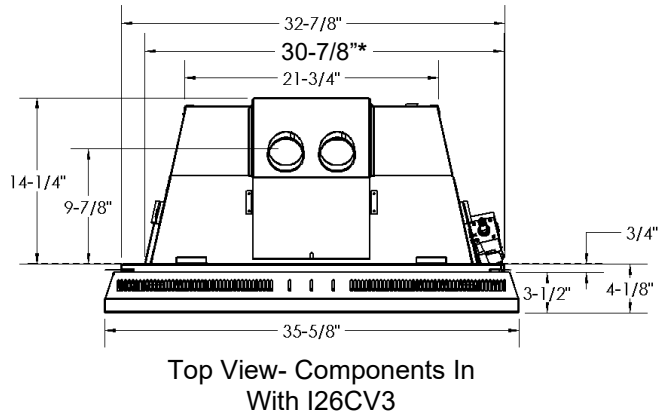
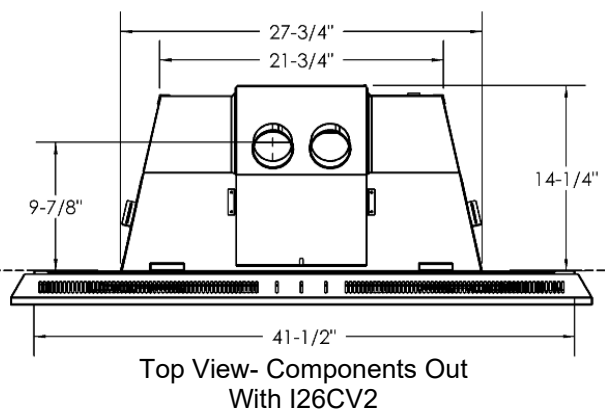
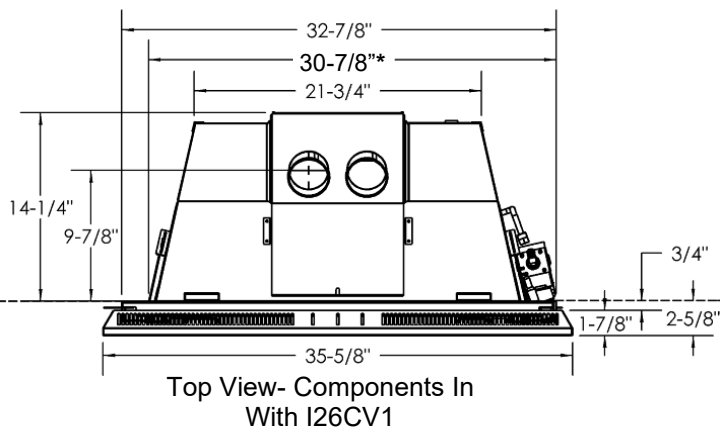
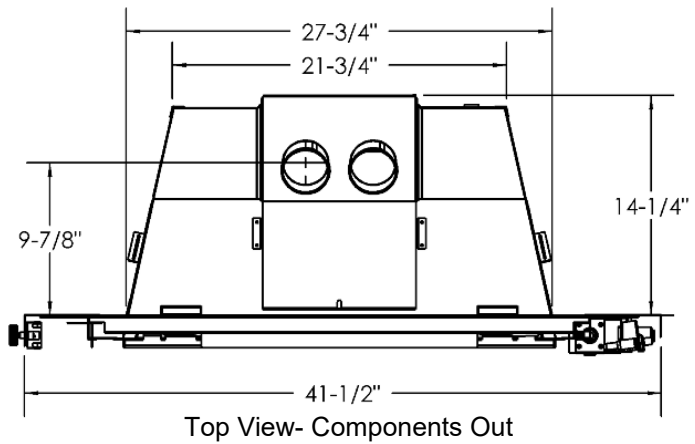
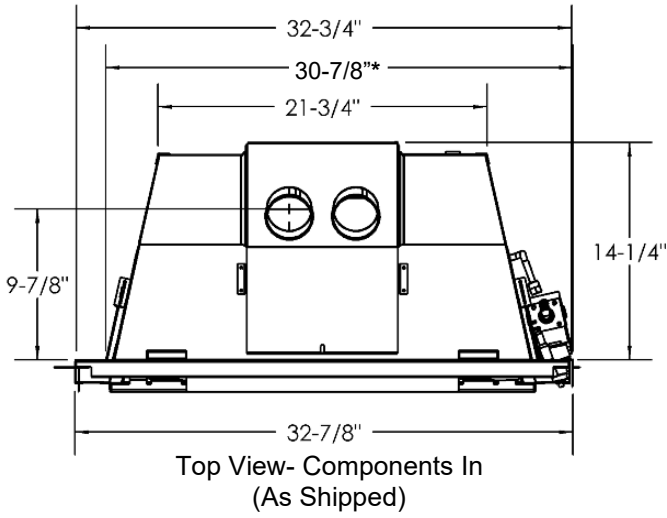

## I26CV Clean View and Surround Sizes

\*The Clean Views and Surrounds in this section must be used with Valve Control Components inside the opening (as shipped).

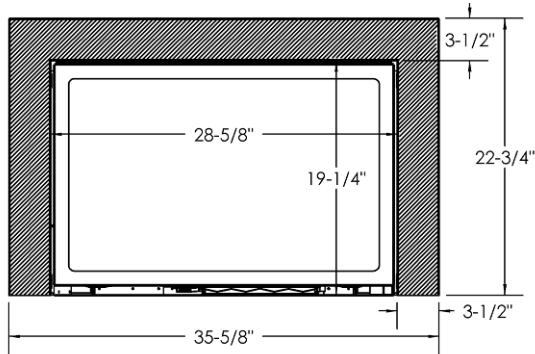

Clean View Kit I26CV1, I26CV3

**Dimensions  
are to  
Inside Edge  
of Clean  
View.**

**Note: If a  
completely tight  
fit to the wall is  
desired, CV  
requires I26S1  
or I26SPF1.**

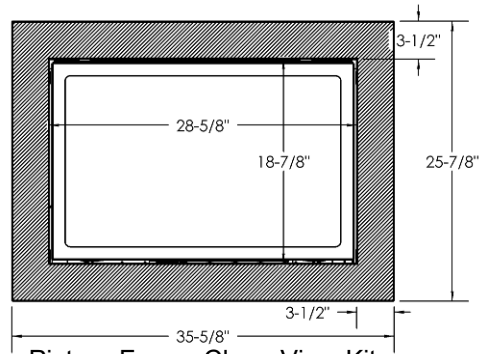

Picture Frame Clean View Kit  
I26CVPF1, I26CVPF3

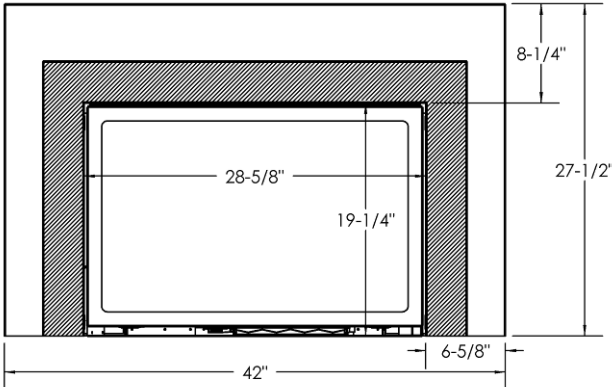

Clean View Kit I26CV1, I26CV3 with  
Rectangular Surround I26S1

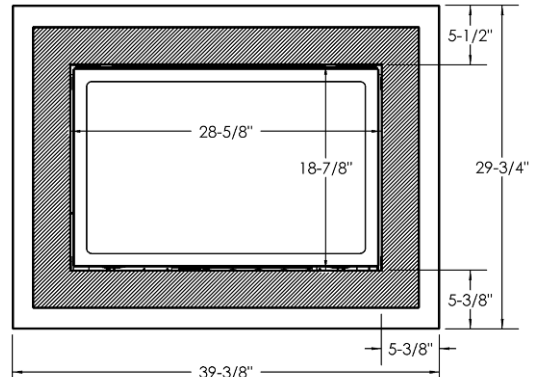

Picture Frame Clean View Kit I26CVPF1, I26CVPF3,  
with Picture Frame Surround I26SPF1

\*The Clean Views in this section can be used with Valve Control Components inside or outside the opening, HOWEVER- if controls are outside, these Clean Views MUST be used to cover valve controls.

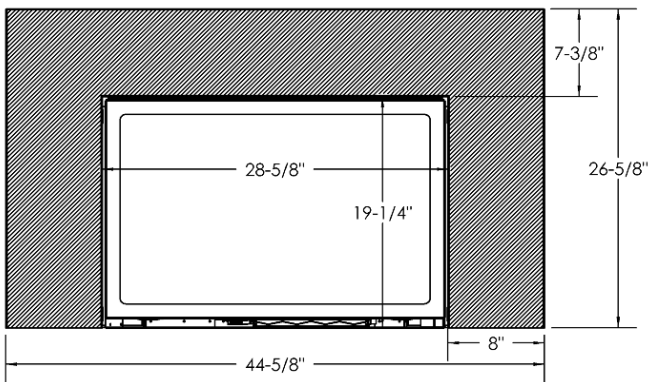

Clean View Kit I26CV2

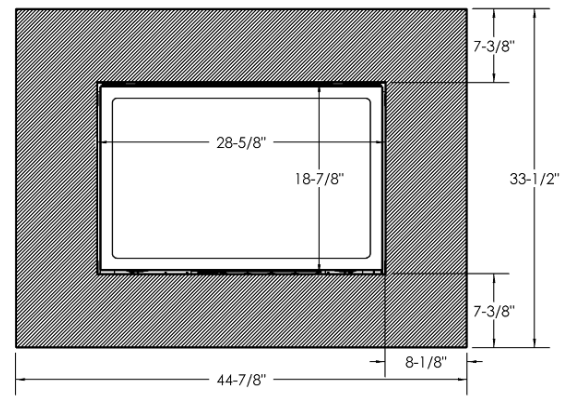

Picture Frame Clean View Kit I26CVPF2

A Universal Surround is available for the IDV26. This is provided as a flat sheet which mounts onto the unit and is to be cut to size and formed by the installer. Flat Surround Shown dimensioned.

**Components In**

**Components Out**

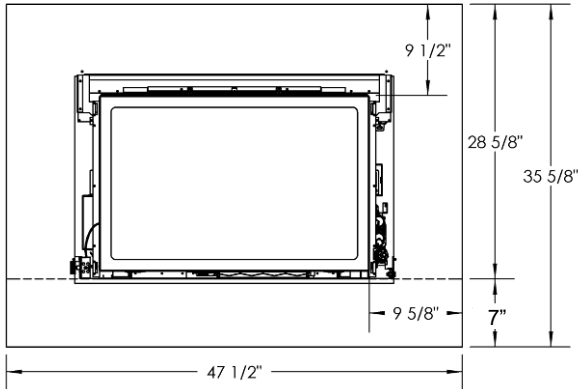

I26SU installed on unit.

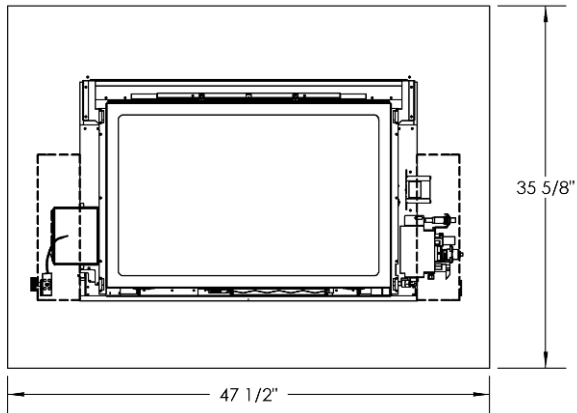

I26SU must be trimmed to fit around Valve Control Components.

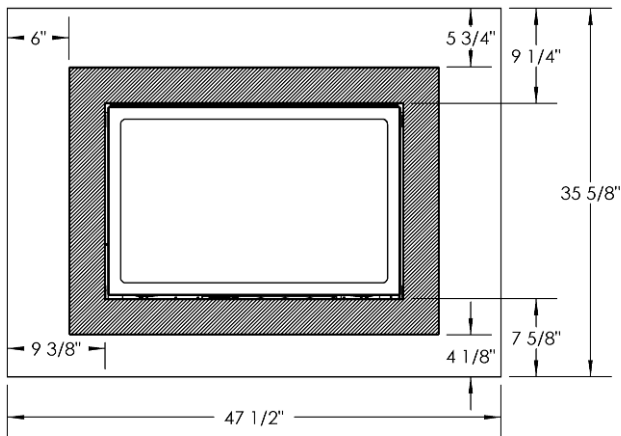

Picture Frame Clean View Kit I26CVPF1 or I26CVPF3 With Universal Surround I26SU

Dimensions are to Inside Edge of Clean View.

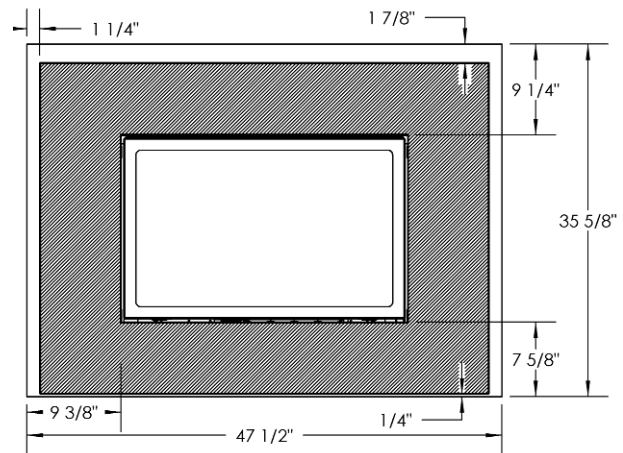

Picture Frame Clean View Kit I26CVPF2 With Universal Surround I26SU

Refer to Worksheet on next page to trim for use as a 3-sided surround or for a custom layout.

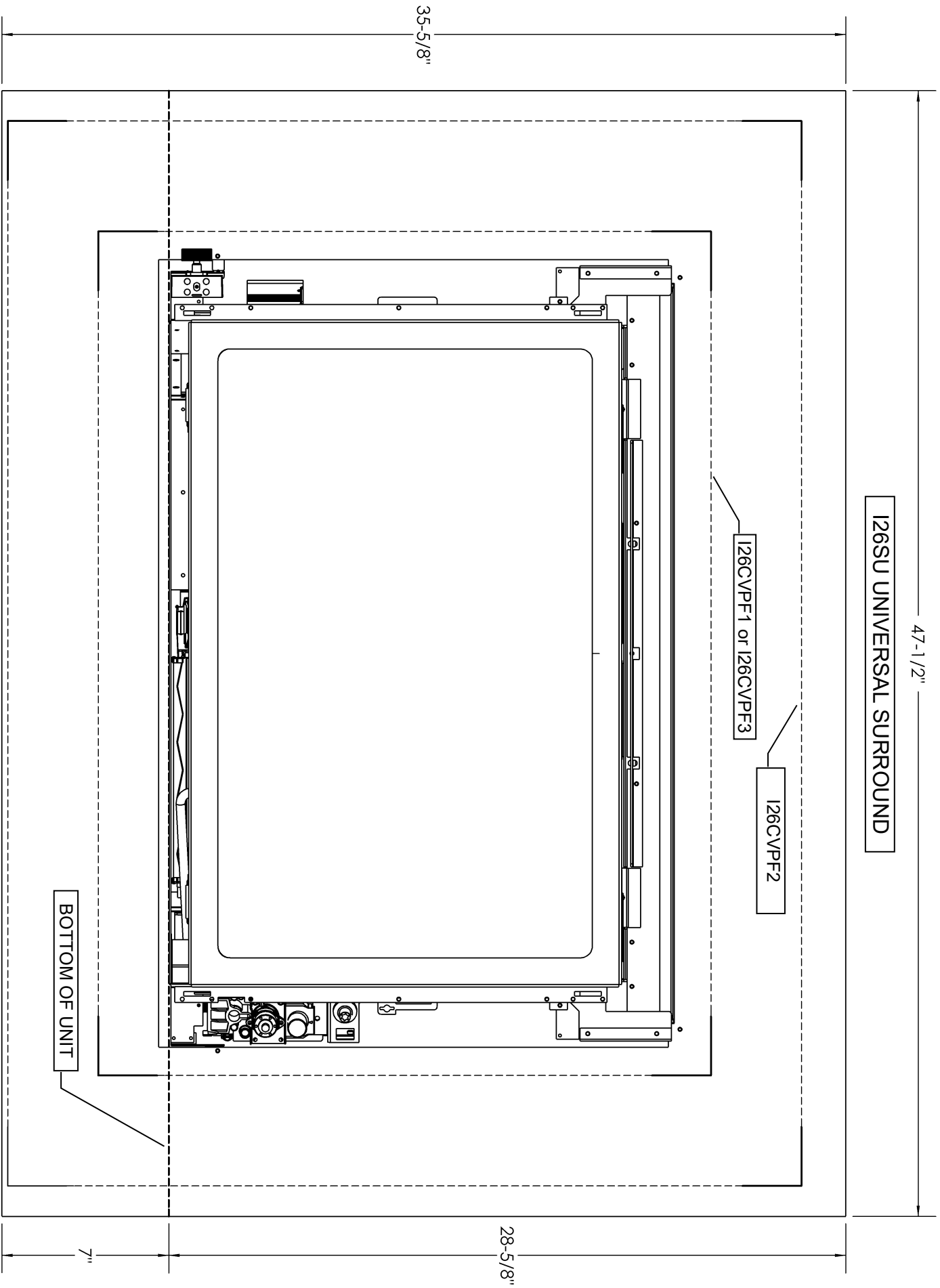

**I26CV1, I26CV2, I26CV3, - Clean View and Surround Attachment**  
**-Surround Installation**  
**-Clean View (CV) Attachment**  
**-Valve Access**

1. **Optional Surround Kit (I26S, I26SPF, I26SU)** is fastened to the insert by pulling up [4] Surround Mount Tabs on the unit and using [4] #6 screws provided with surround.
2. Insert the **Clean View (I26CV1 or I26CV3, I26CV2 or I26CVPF1 or I26CVPF3, I26CVPF2 or I26CVPF3)** Mounting Tab into the Clean View Mounting Slots (four [4] places) and lower the Clean View kit into place.
3. **Valve Access:** To access valve simply remove Clean View. Replace Clean View as per item [2] above once adjustments to valve have been completed.

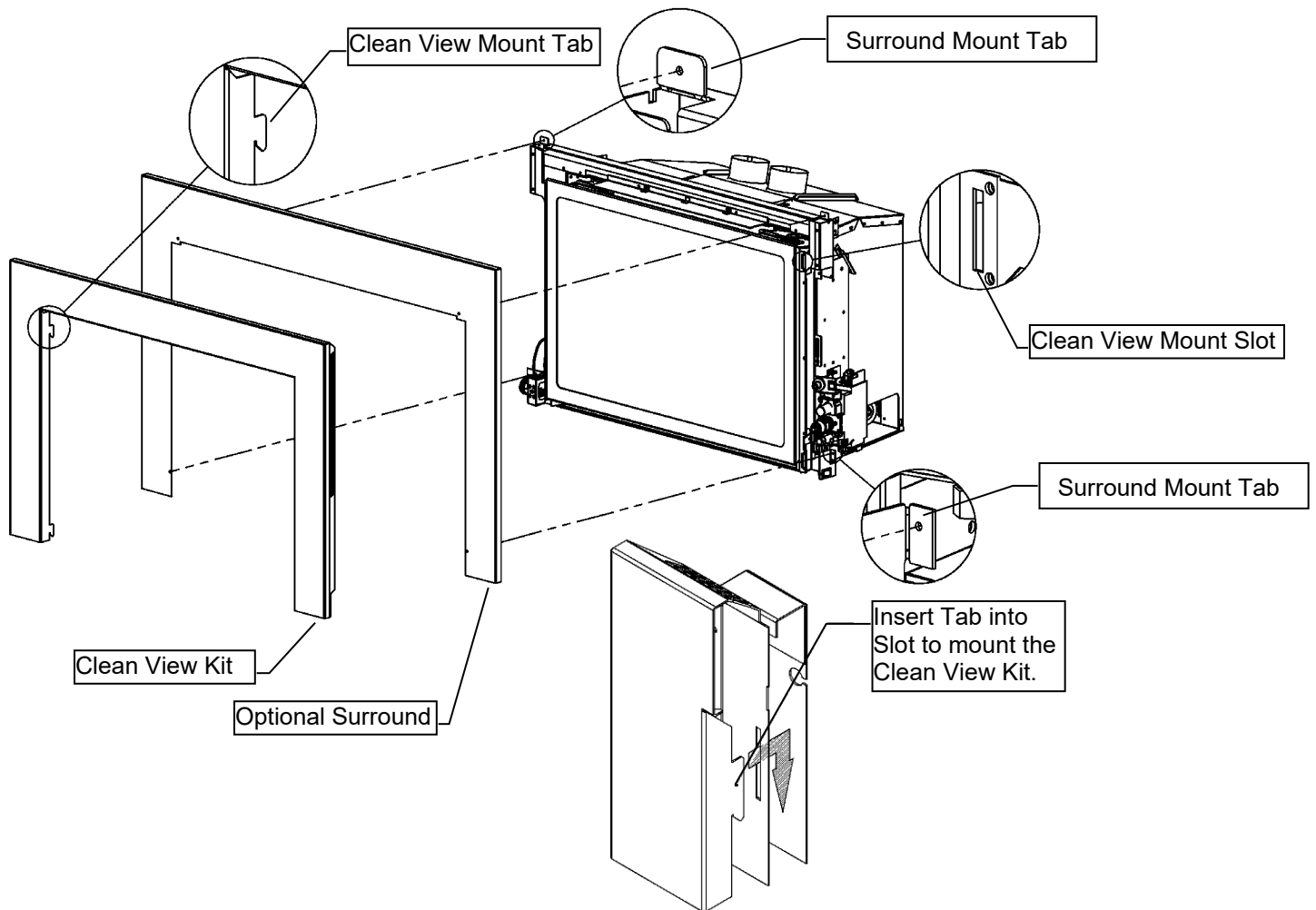

**NOTE: The Clean View Surround needs to be removed in order to access the Glass Door, access the valve, and service the unit.**

Valve positioned as per manufacturer's instructions.

Component List: I26S1 / I26SPF1 / I26SU Surround, [Qty 4] #6 Black Combo Screws

**Bend Up All 4 Mount Tabs**



Top Left



Top Right

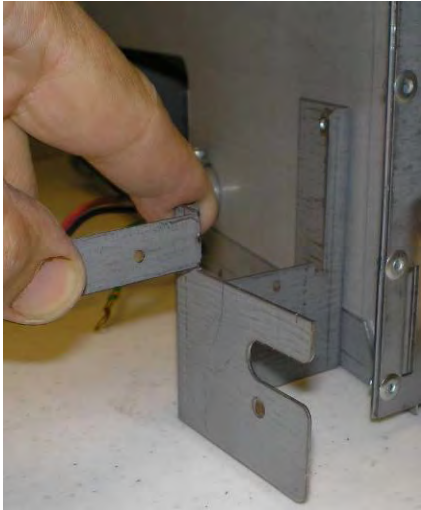

Bottom Left

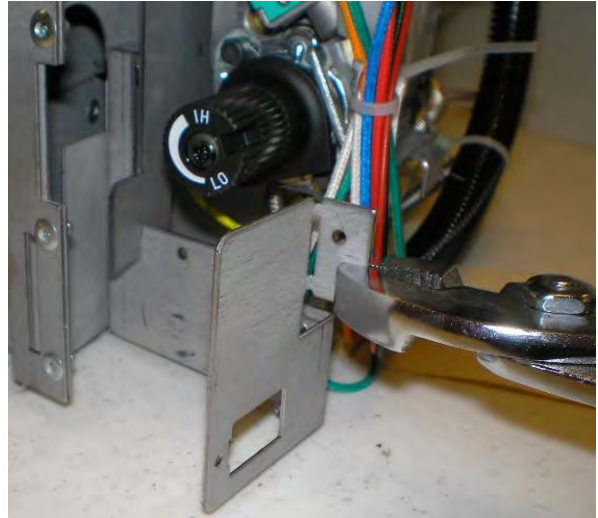

Bottom Right

Place Surround onto unit and line up holes in mount tabs with holes in Surround. Attach with screws provided.

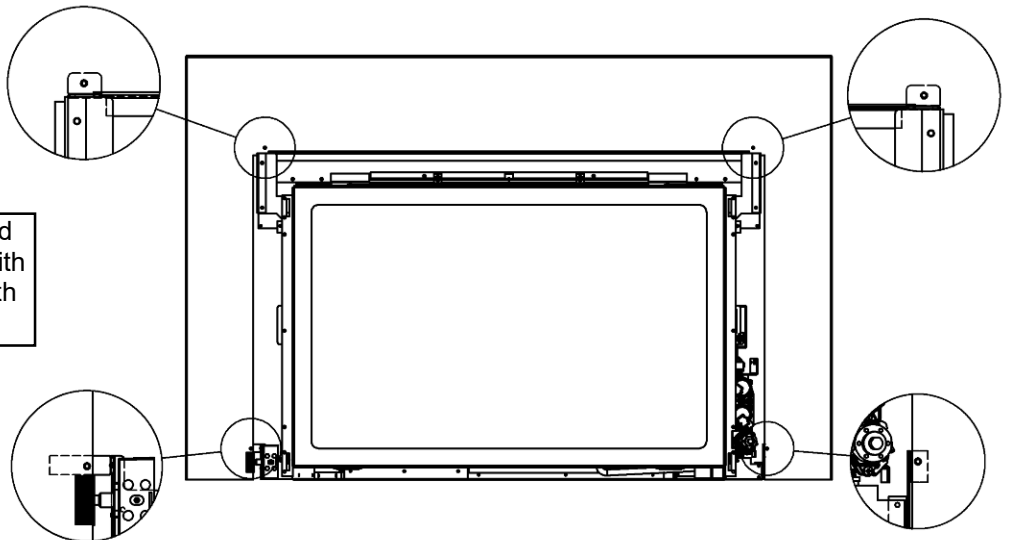

Component List:

- I26CV2 / I26CVPF2 Clean View
- On/ Off Switch Extension Bracket
- Fan Control Switch Extension Bracket
- [4] #6 Black Combo Screws

**Components In (As Shipped):**

**Fan Control Switch Bracket**



**1** Remove Fan Control Switch From Current Position.

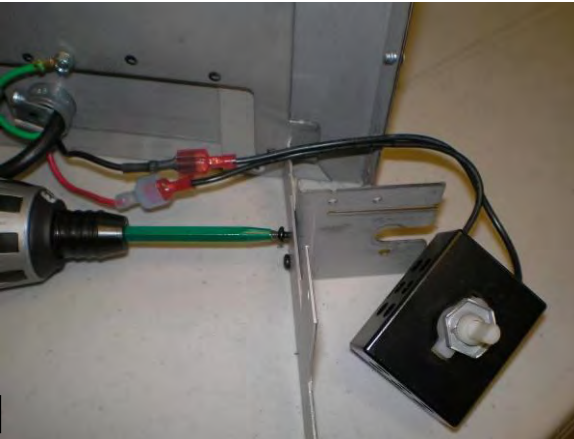

**2** Attach Fan Control Switch Extension Bracket using [2] #6 Combo Screws as shown.

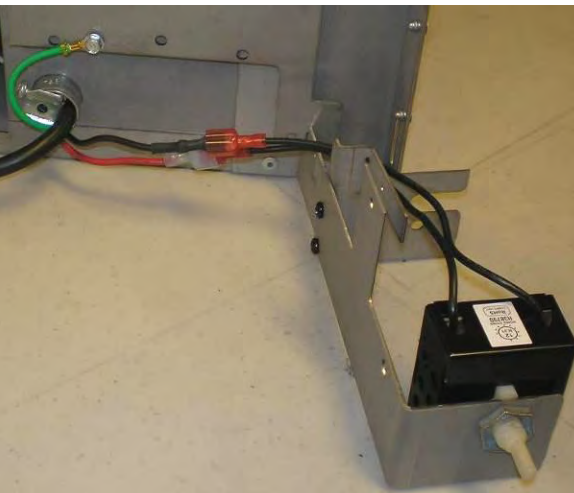

**3** Mount Switch & route wiring as shown.

**On/Off Switch Bracket**

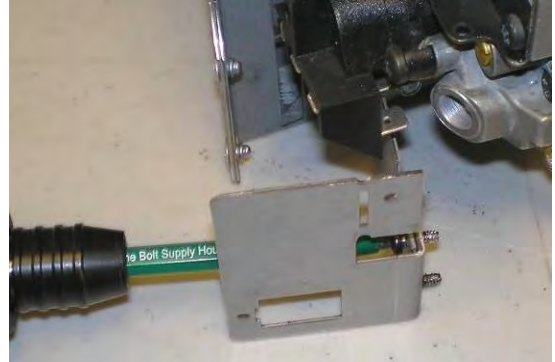

**1** Remove On/Off Switch and original mount bracket.

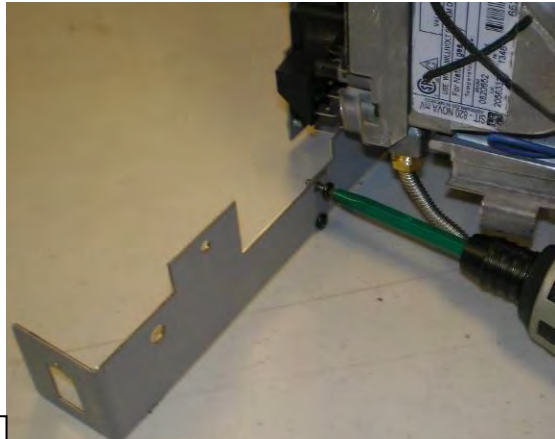

**2** Attach On/ Off Switch Extension Bracket using [2] #6 Combo Screws as shown.

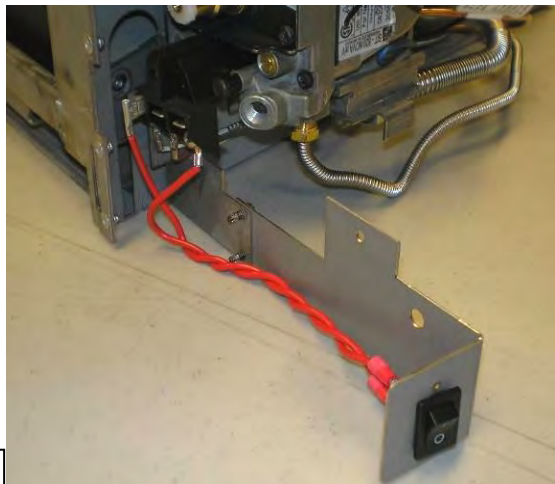

**3** Mount Switch & route wiring as shown.

Insert Mount Tabs into slots in unit and lower Clean View into place. Refer to Clean View Attachment.



## Components Out

### Fan Control Switch Bracket

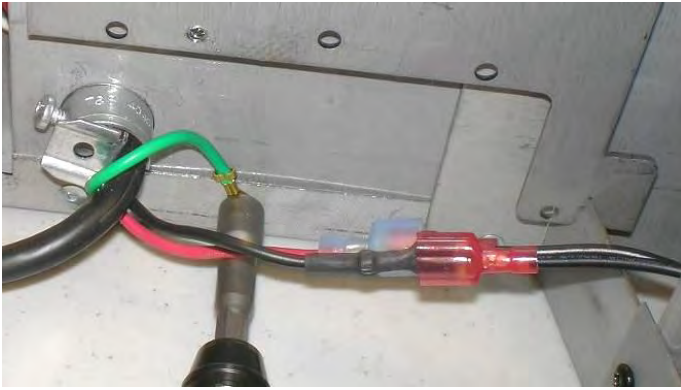

**NOTE:** If Ground is attached to Side Component Plate, remove and fasten to side of appliance with a DT Screw.

Remove Fan Control Switch From Current Position.



2

Attach Fan Control Switch Extension Bracket using [2] #6 Combo Screws.



3

Mount Switch & route wiring as shown.

### On/Off Switch Bracket



1

Remove On/Off Switch and original mount bracket.

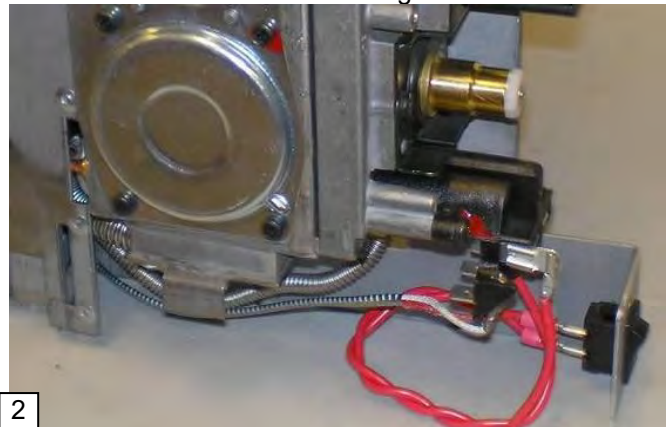

2

Attach On/ Off Switch Extension Bracket using [2] #6 Combo Screws as shown.



3

Mount Switch & route wiring as shown.

Insert Mount Tabs into slots in unit and lower Clean View into place. **Refer to Clean View Attachment.**



**IDV26PL Parts List:**

- 1 Back Panel
- 1 Right Side Panel
- 1 Left Side Panel

**To Remove:**

1. Remove **Log Supports**. Remove the [5] screws in the firebox top holding the **Baffle** in place.
2. **Remove Back Panel**. Unscrew and remove the Back Panel. Slide and tilt to remove. **NOTE:** If you will be installing a porcelain Back Liner, unscrew Back Panel Air Deflector and install on porcelain Back Liner.
3. **Remove Side Panels** (if present). Remove screw. Tilt and slide Side Panels out of fireplace.

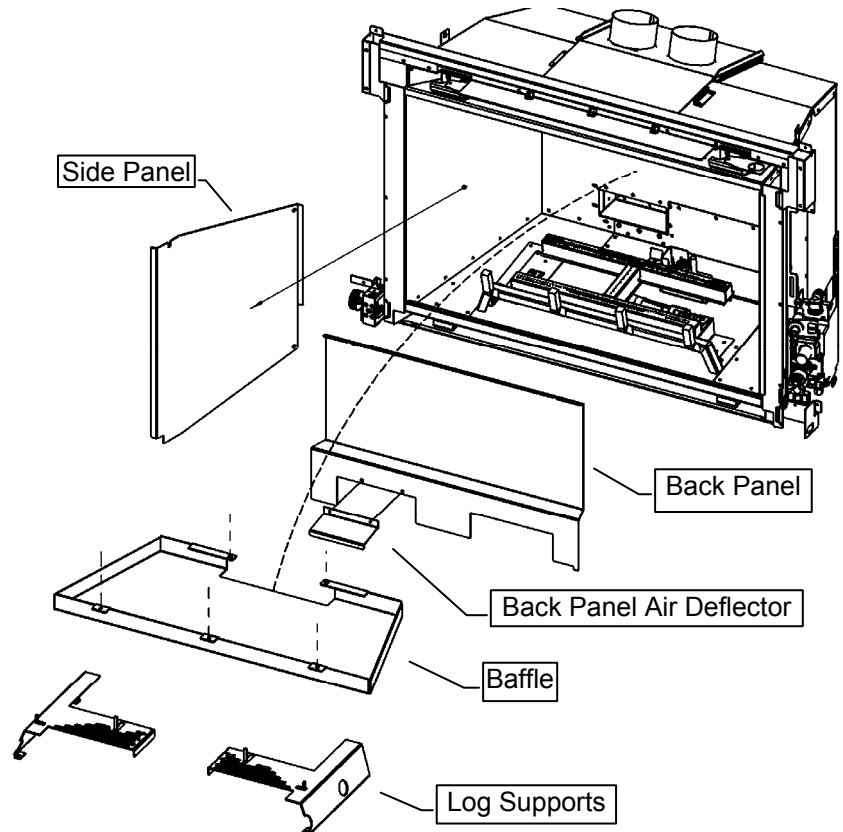
**To Install:**

1. **Install Side Panels**. If you are using Side Panels, install them first. Tilt and slide Side Panels into place. Secure with screw in side of firebox.
2. **Install Back Panel**. Ensure that Back Panel Air Deflector is in place on Back Panel (See Illustration). Place Back Panel up against the back of the Firebox and reinstall the [2] Screws in firebox top. Then slide lower Liner Retainer Clip (located on bottom of firebox behind burner) up to bottom of Back Panel & tighten.
3. **Replace Baffle**. Replace Baffle and proceed with Log or Rock/Glass Tray setup.

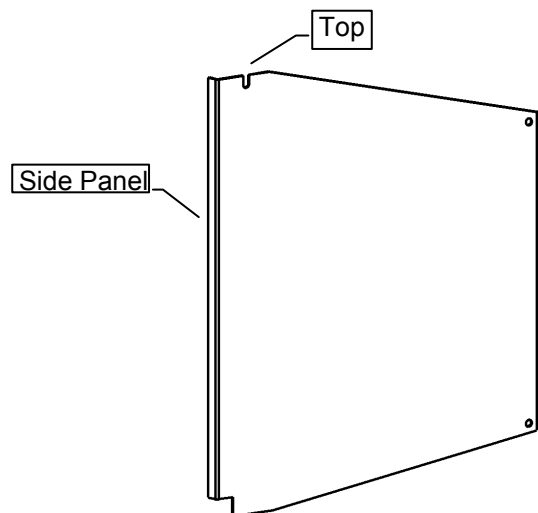
**Note: Warping and Discoloration of Porcelain or Painted Metal Liners Is Not Covered Under Warranty.**

Both Porcelain and Painted Metal Liners may discolor and warp during normal operation of your appliance. This is normal, and not considered a defect.

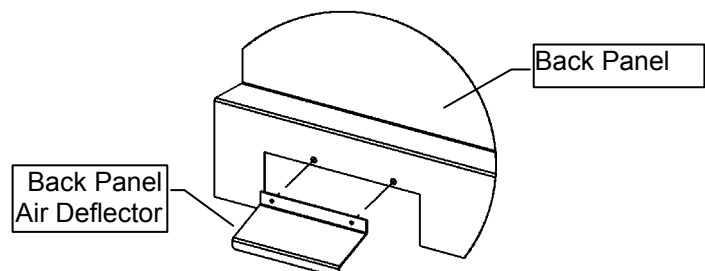

**IDV26RL Parts List:**

- 1 Back Panel
- 1 Right Side Panel
- 1 Left Side Panel

**To Install:**

1. **Remove the Baffle.** Remove the [5] screws in the firebox top holding the Baffle in place. Remove the [2] Liner Retainer Clips in the firebox top also.
2. **Install Back Panel.** Place Back Panel on the rear ledge inside the firebox.
3. **Install Side Panels.** Twist and rotate Side Panels into place. Secure with Liner Retainer Clips in top of firebox..
4. **Replace Baffle.** Replace Baffle and proceed with Log or Rock/Glass Tray setup.

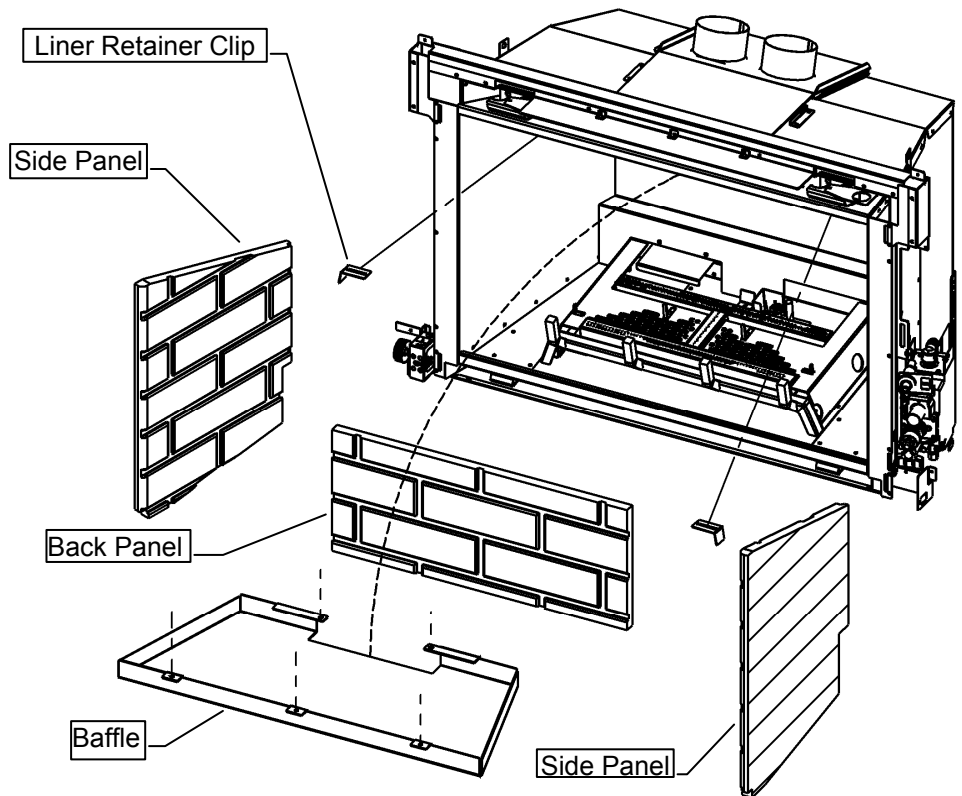

**Warning:** Failure to position the parts in accordance with these diagrams or failure to use only parts specifically approved with this appliance may result in property damage or personal injury.

**NOTE:** It is not necessary to disconnect pilot lines and gas supply line from valve to complete this procedure. **Care should be taken to ensure that the gas and pilot lines are not damaged during handling. These lines are fragile.**

**This procedure must be done Before the unit is inside the enclosure.**

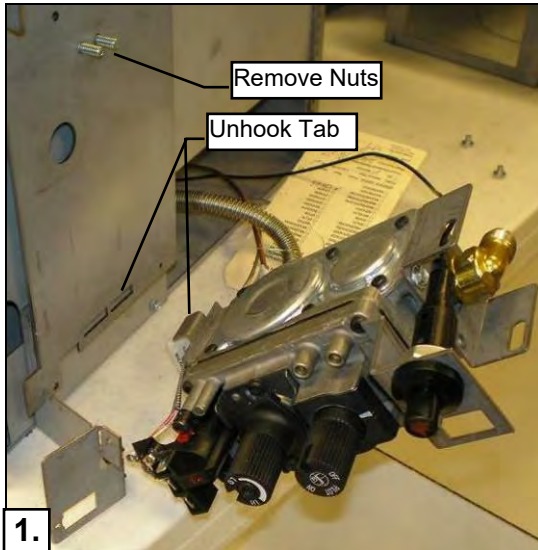

1. Remove [2] 3/8" nuts holding valve onto Component Panel. Unhook valve from Component Panel.

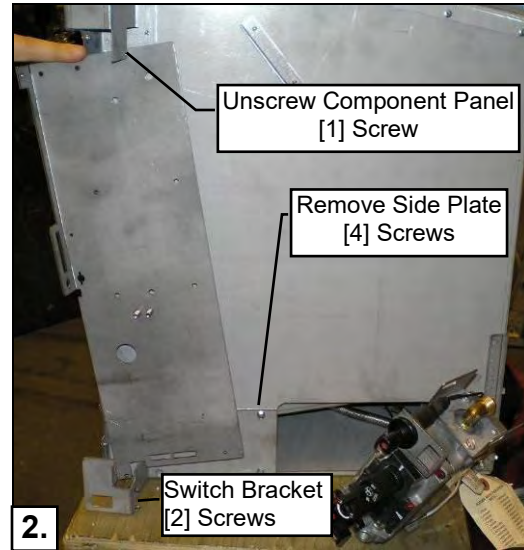

2. Remove Component Panel, Switch Bracket, and Side Plate.

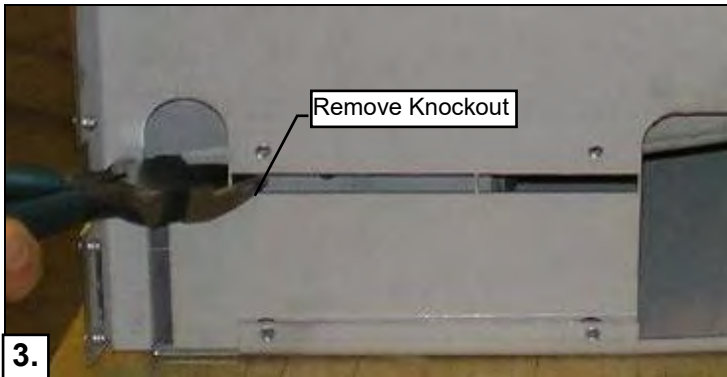

3. Remove knockout with side cutters, if present. Discard knockout.

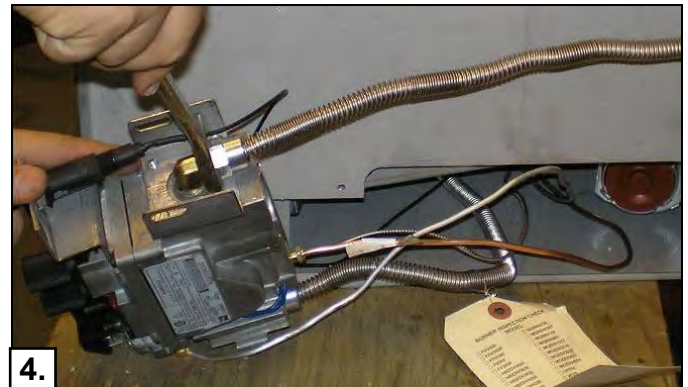

4. Connect flex to inlet side of valve. This can then be connected to the gas supply and routed through the channel inside the fireplace.

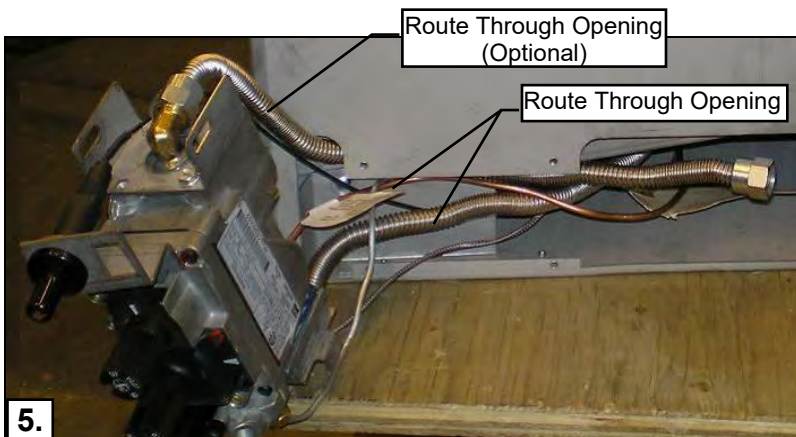

5. Route valve connections through the opening.

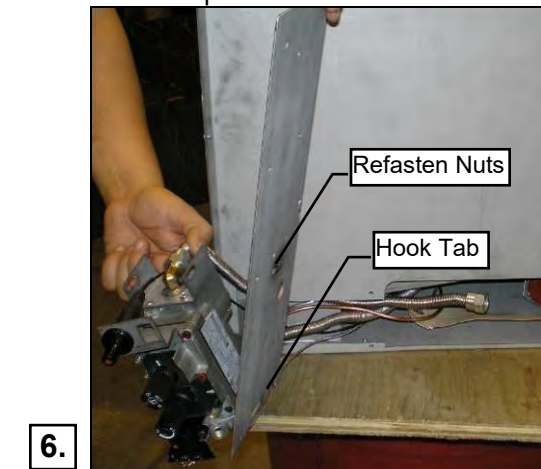

6. Mount Component Panel on opposite side of valve.



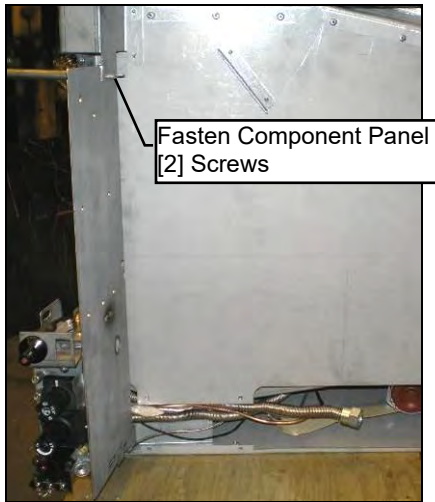

**7.** Fasten Component Panel at top.

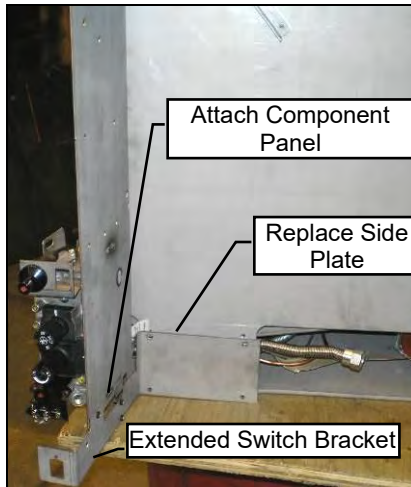

**8.** Replace Side Plate. Attach Component Panel and Extended Switch Bracket.

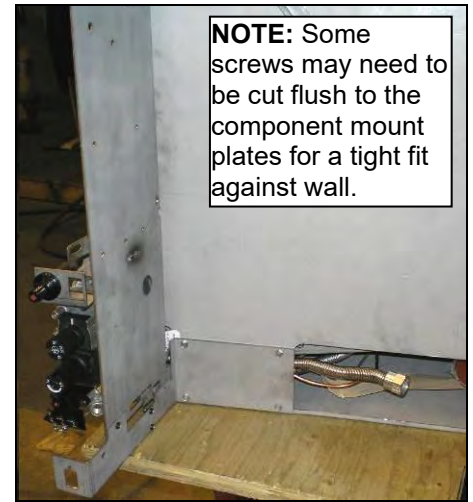

**9.** Procedure is complete.

**NOTE:** Some screws may need to be cut flush to the component mount plates for a tight fit against wall.

**IDV26 -IPI- -Control Components Outside the Opening- -COMPONENTS OUT-**

\*Refer to Millivolt section for more detailed photos & instructions.

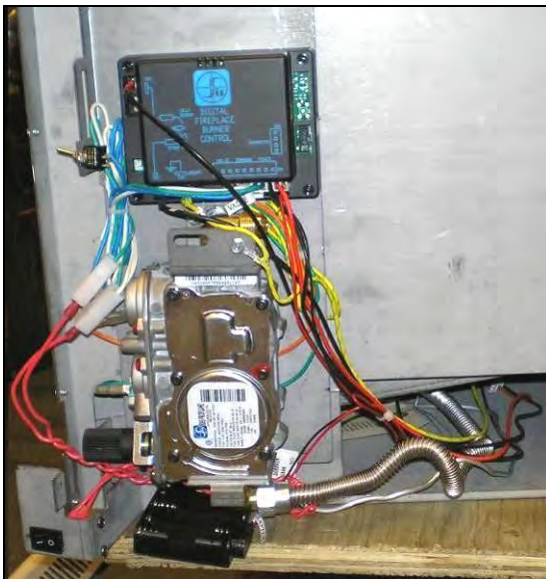

**1.** Ready to begin.

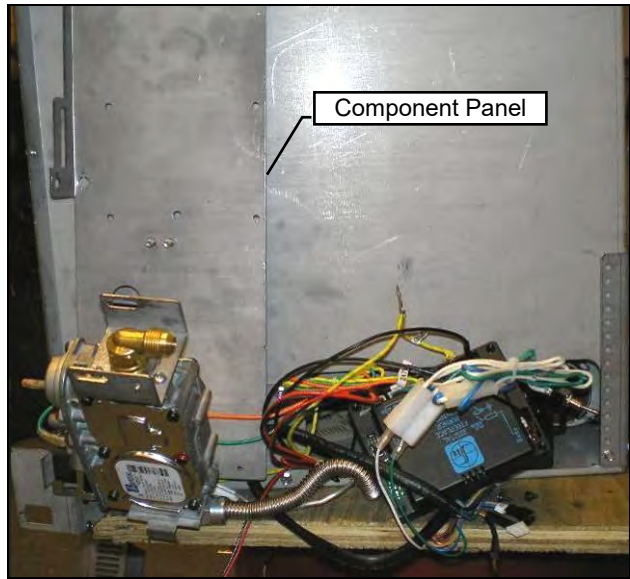

**2.** Remove All Components from Component Panel. Remove Component Panel from fireplace.

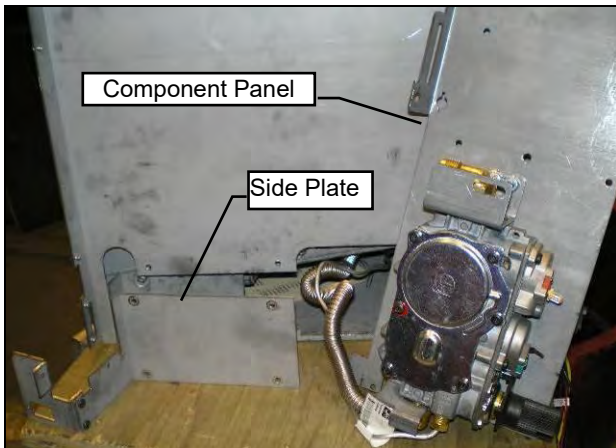

**3.** Remove Side Plate and knockout if present (see millivolt section). Place Component Panel on other side of valve.

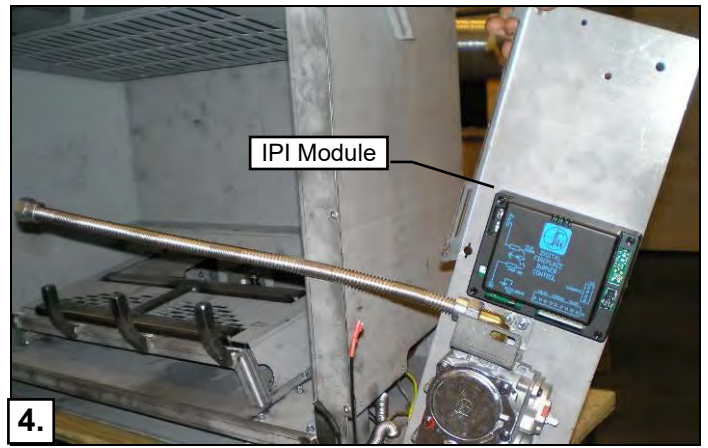

**4.** Connect flex to inlet side of valve. This can then be connected to the gas supply and routed through the channel inside the fireplace. (see millivolt section).



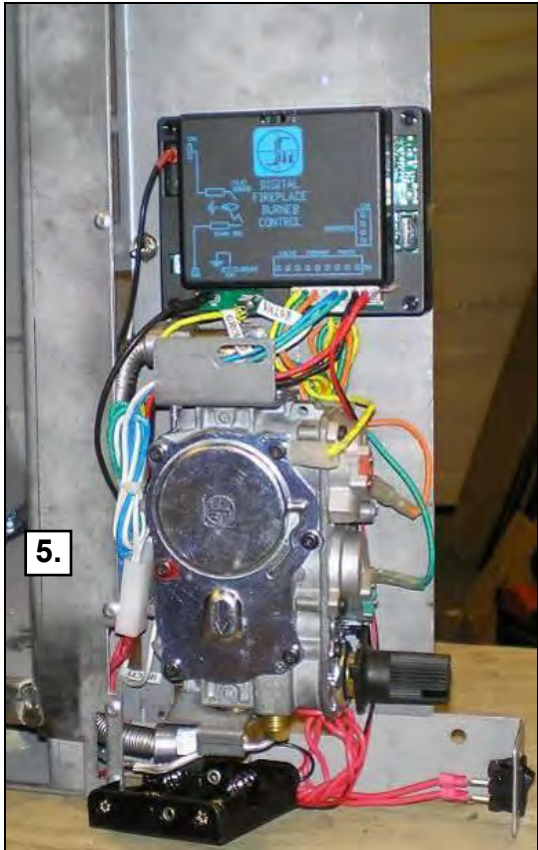

5.

Replace Side Plate. Fasten Component Panel at top & bottom. Attach Component Panel and Extended Switch Bracket (see millivolt section).

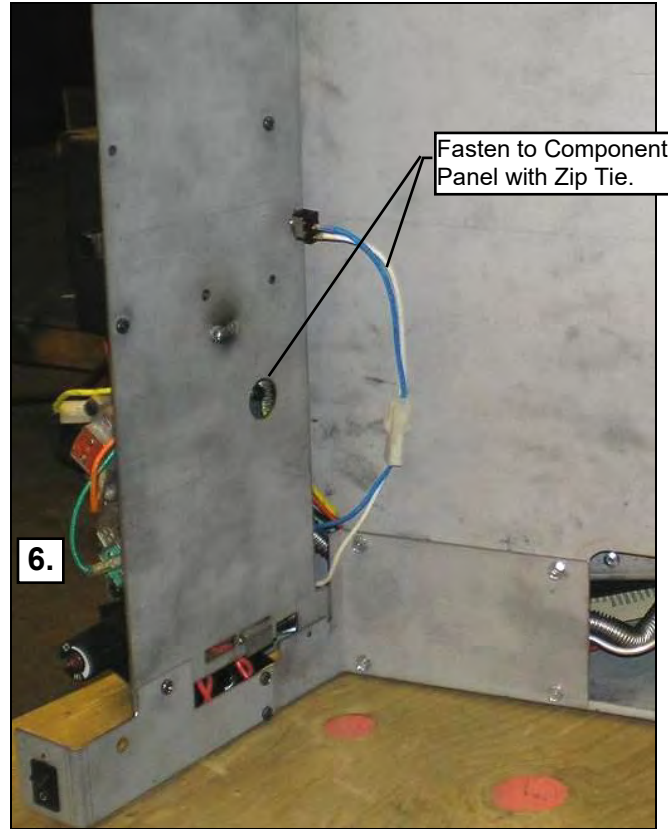

6.

Fasten to Component Panel with Zip Tie.

Procedure is complete.

**NOTE:** Some screws may need to be cut flush to the component mount plates for a tight fit against wall.



MILLIVOLT- COMPONENTS OUT



IPI- COMPONENTS OUT

**Warning:** Failure to position the parts in accordance with these diagrams or failure to use only parts specifically approved with this appliance may result in property damage or personal injury.

NOTE: It is not necessary to disconnect fan wiring to complete this procedure.  
This procedure must be done before the unit is inside the enclosure.

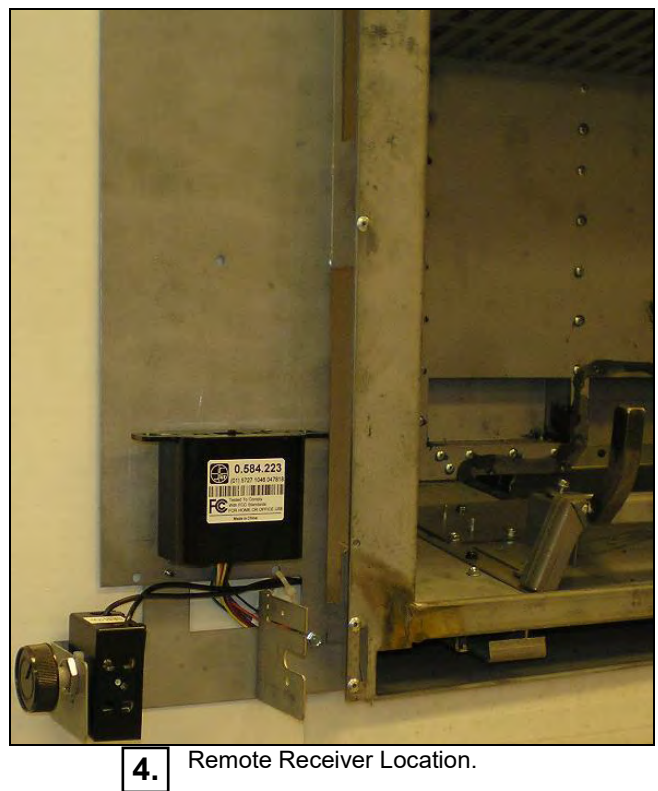
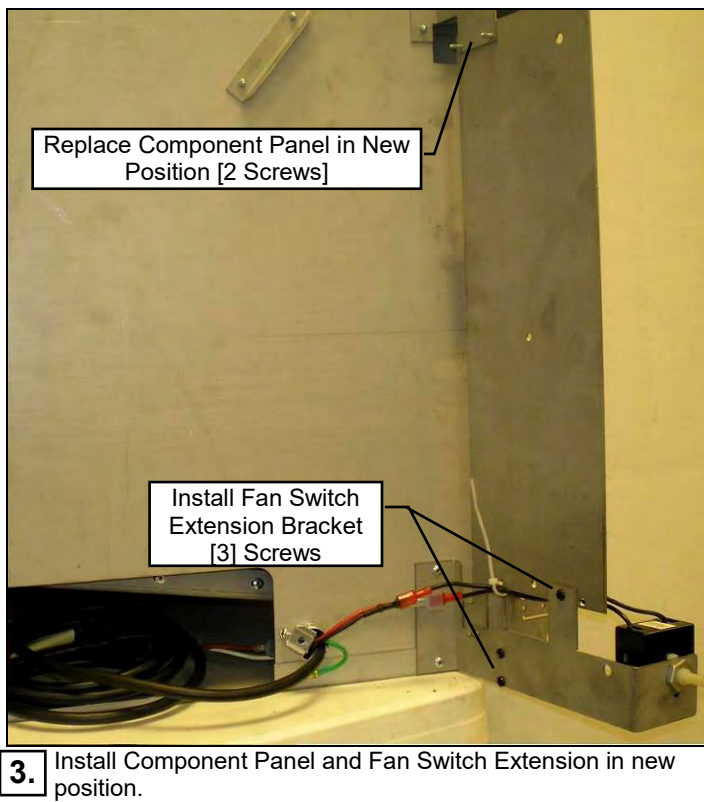
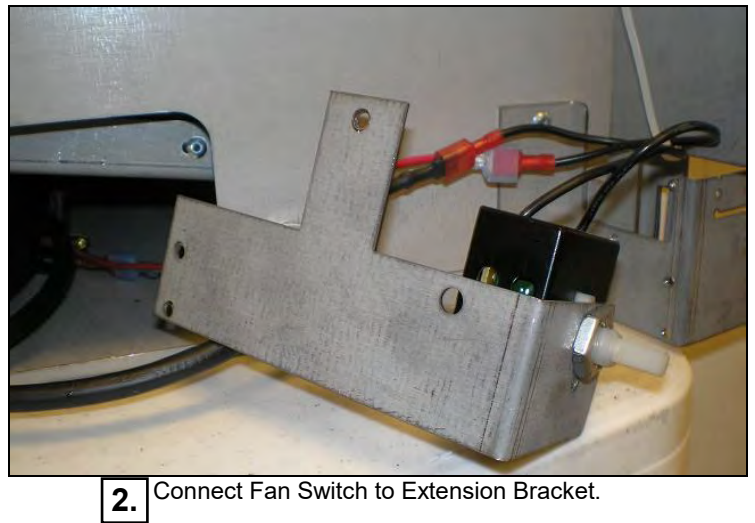
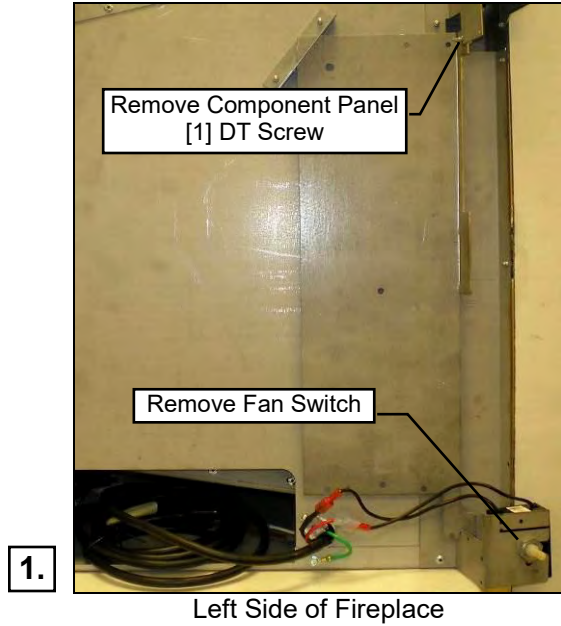



 **WARNING**
**Electrical Grounding Instructions**

This appliance is equipped with a three prong (grounding) plug for your protection against shock hazard and should be plugged directly into a properly grounded three-prong receptacle. Do not cut or remove the grounding prong from this.

**Before Servicing**

1. Ensure all power supply is shut off.
2. Label all wires prior to disconnecting when servicing control. Wiring errors can cause improper and dangerous operation.
3. For fan servicing: Vacuum and clean lint/dirt build-up on the fan blades and motor.

When resealing the Fan Access Panel, use High Temp Silicone or Millpac.

The fan can be accessed from the back of the unit (which is easiest on an uninstalled unit) or through the inside of the firebox.

- To remove or install the fan from the back of the unit, remove the Fan Access Cover from the back of the fireplace. The fan will be attached to this cover (See right).

**Thermodisk Location:** Note the location of the Thermodisk in the photograph below.

**Variable Speed Switch Location:** Note the location of the Variable Speed Switch in the illustration below.

- To remove or install the fan through the inside of the firebox, refer to the procedure below.

1. Remove Grate Bar Assembly, Burner Trim Plates, and Burner. Then remove the [5] screws in the firebox top holding the Baffle in place. Remove the Baffle. Then unscrew and remove the Back Panel.
2. Remove Fan Access Cover (15 screws). It is located on the back and bottom right hand corner. The fan area will now be exposed (See photo below).
3. Unscrew the [2] screws and remove fan. Fan needs to be twisted and rotated slightly. (See photo below).
4. Replace all components and seal Fan Access Cover and Thermodisk Plate with Millpac.
5. Verify proper operation after servicing.

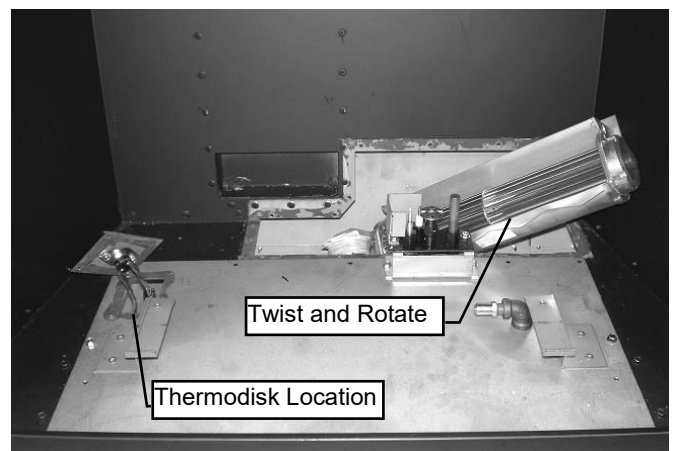
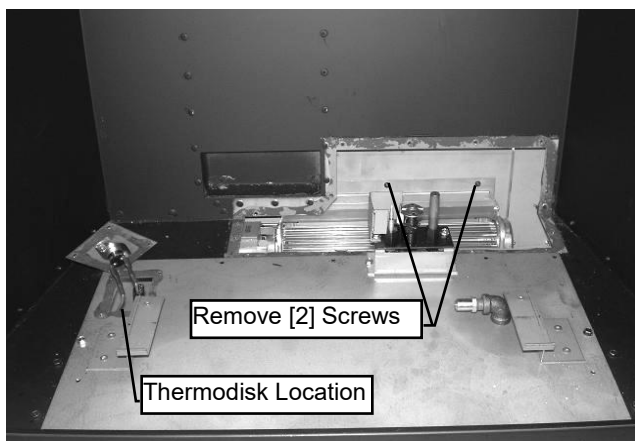
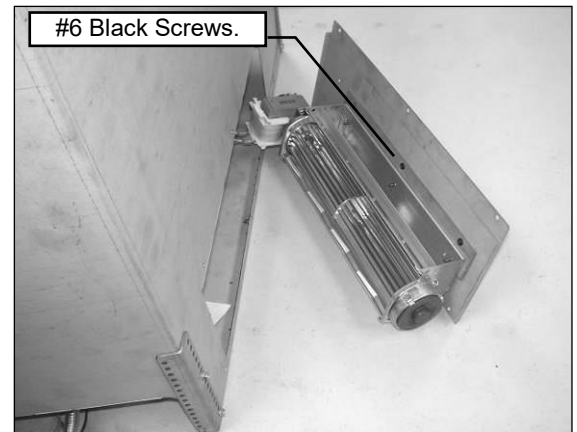
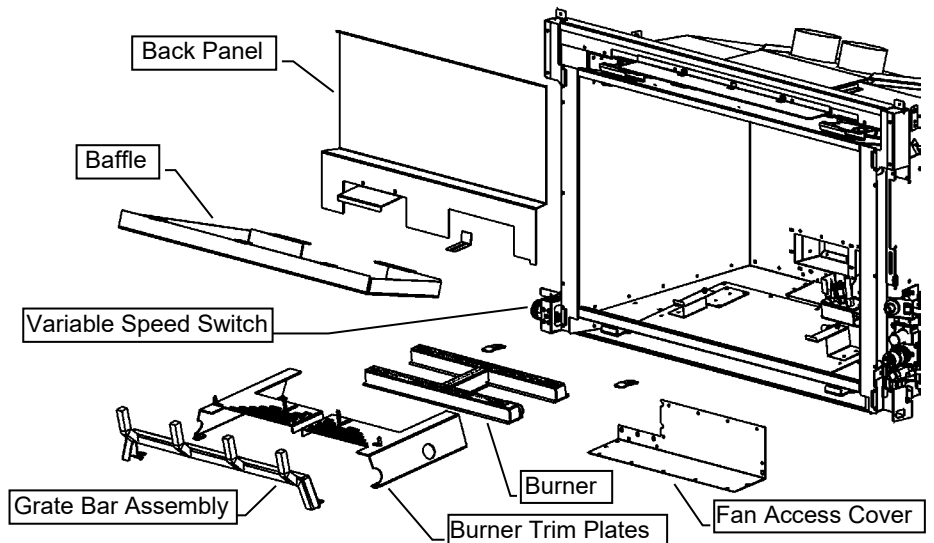

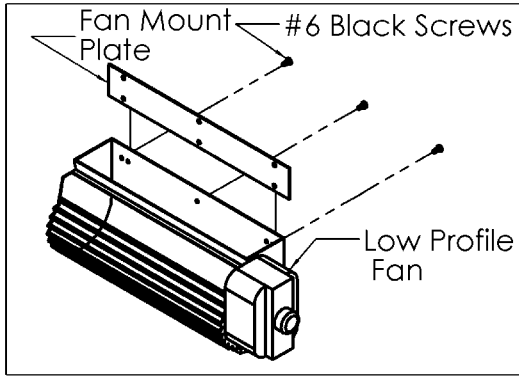

**Inside of Fireplace**

**Outside of Fireplace**

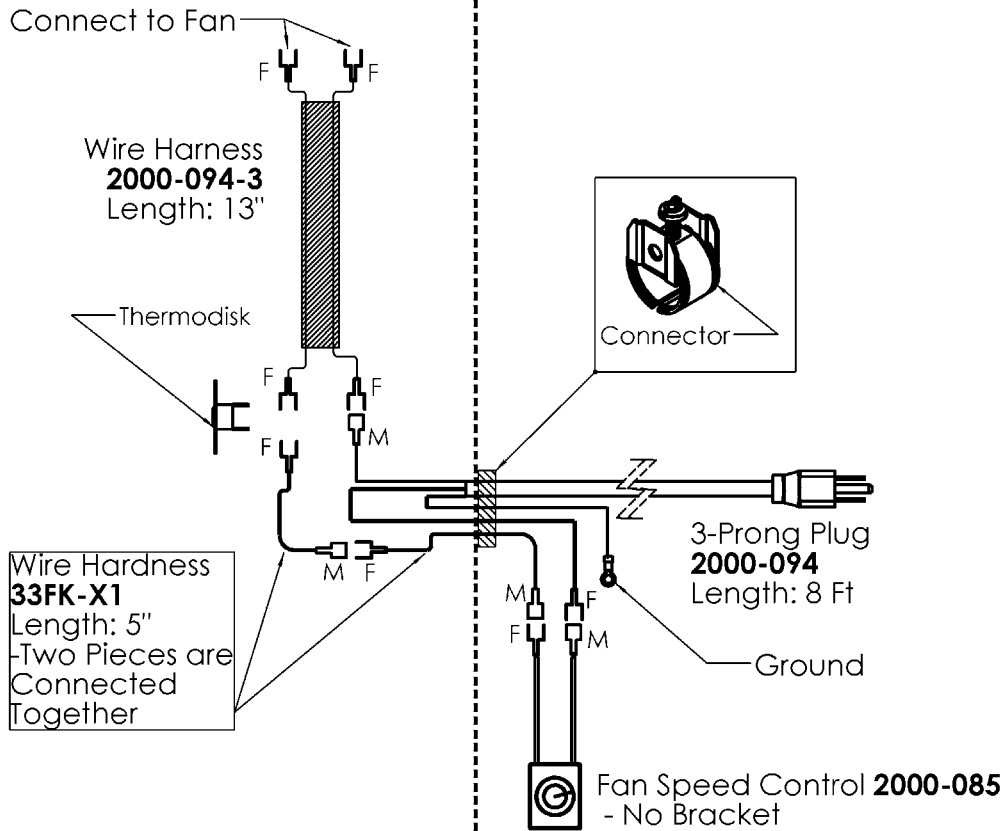

**Components In -Left Side of Unit**

**Components Out- Left Side of Unit**

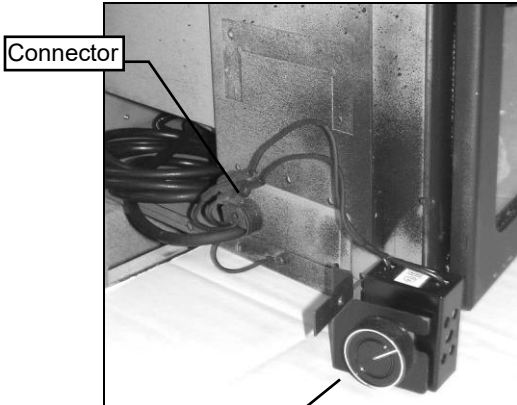

Variable Speed Switch

Variable Speed Switch



**Connecting to the Gas Valve**

The wiring harness for the Proflame GTM system has two wires labeled “TH” & “TPTH”. Connect the wires to the gas valve as labeled. (TH to TH and TPTH to TPTH). Additionally there is a connector labeled “Motor”. Connect this “Motor” connector to the stepper motor on the gas valve (if present).

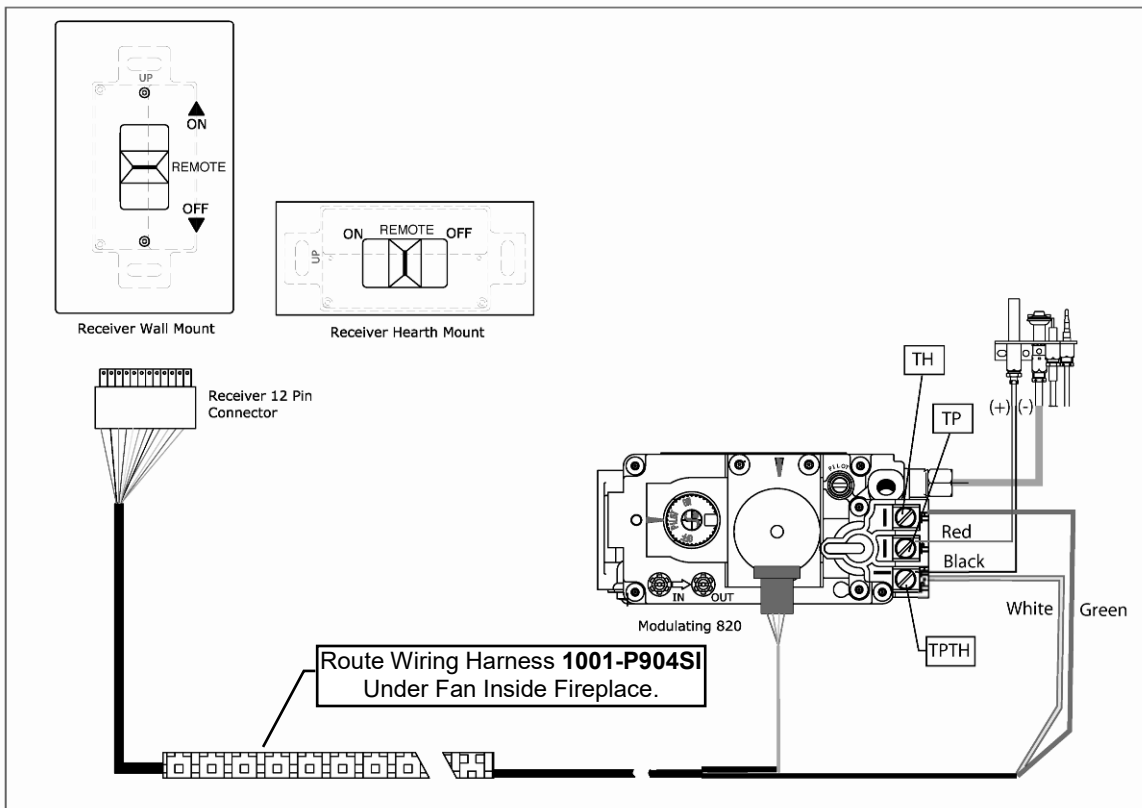

Left Side of Fireplace

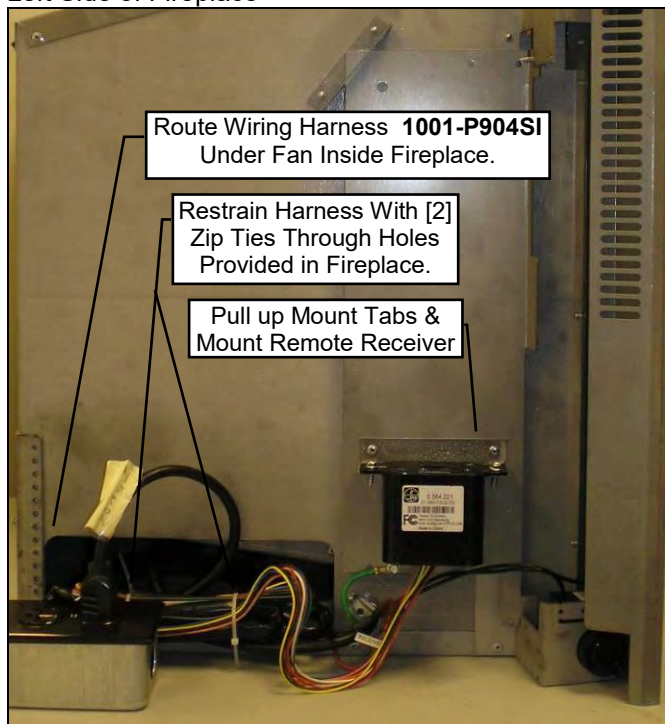

Components In (As Shipped)



Components Out Remote Receiver Location.

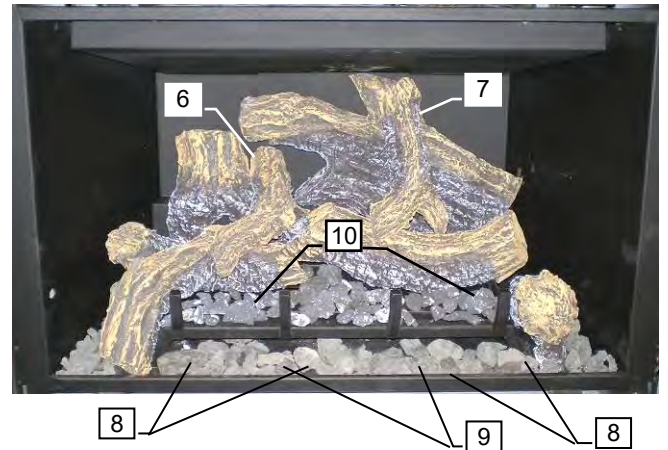
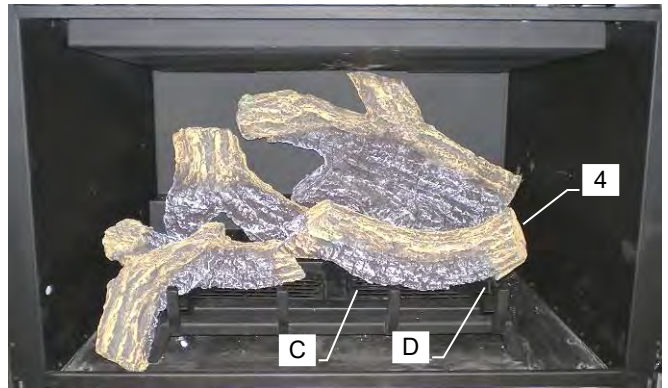
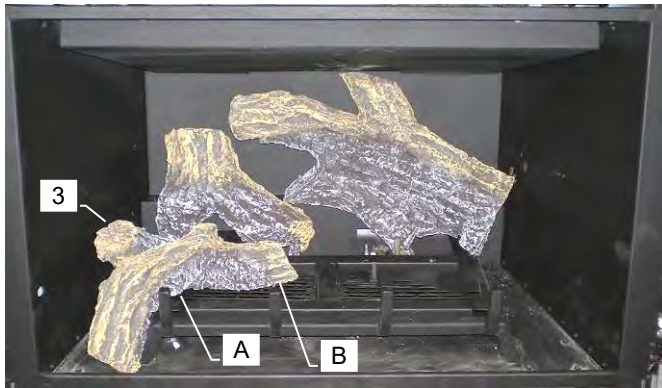
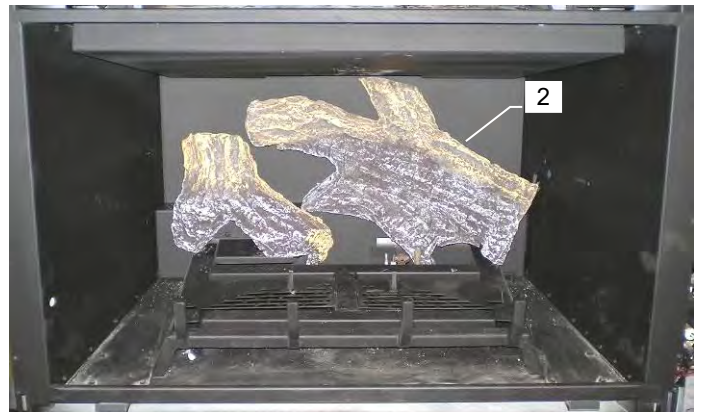
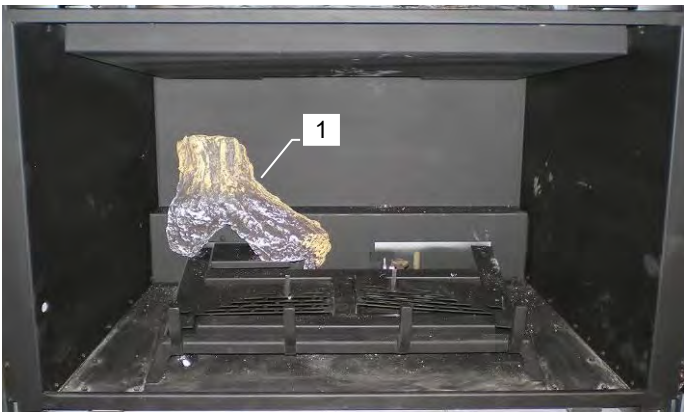
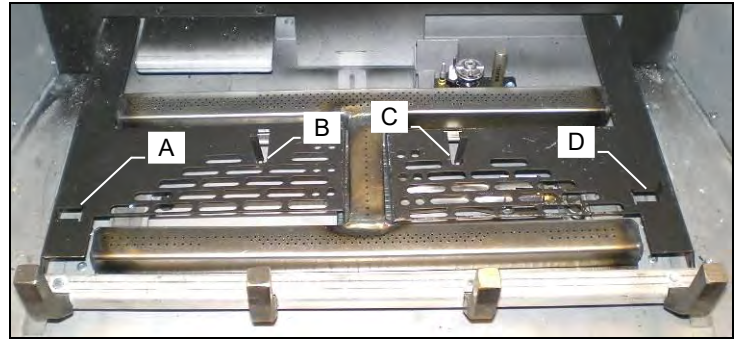

**WARNING:** Failure to position the parts in accordance with these diagrams or failure to use only parts specifically approved with this appliance may result in property damage or personal injury.



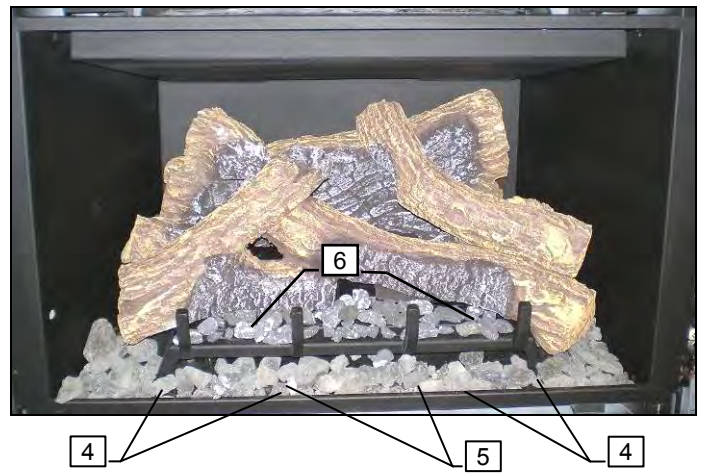
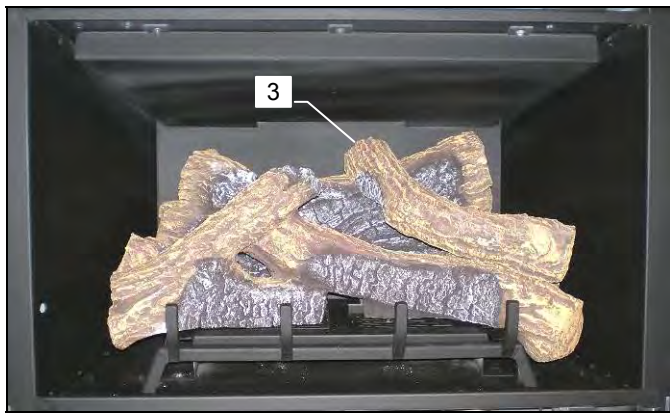
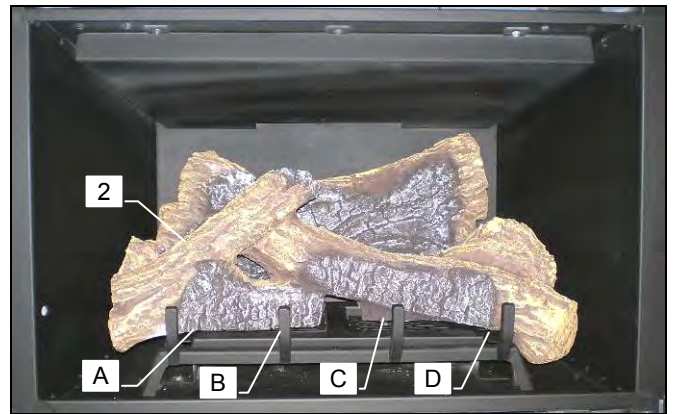
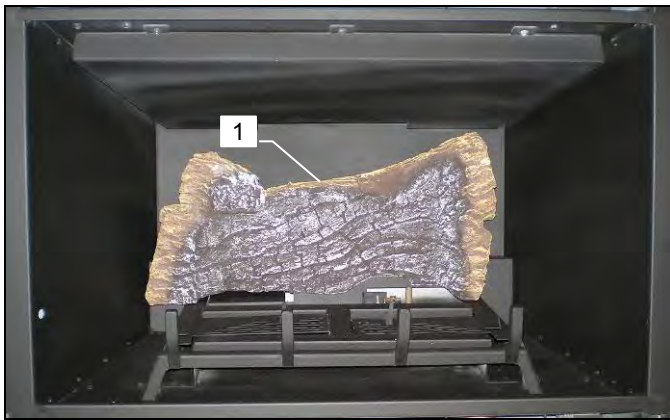
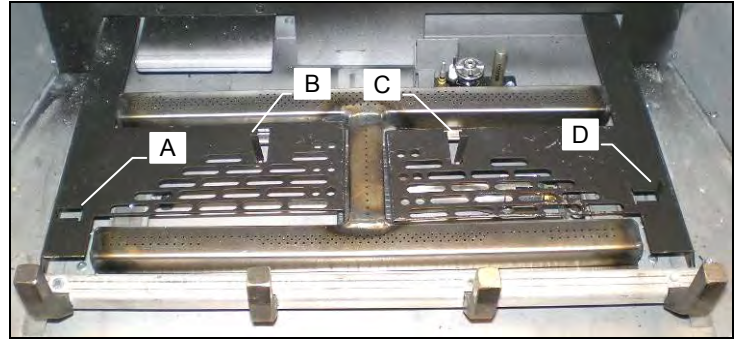

**⚠ WARNING:** Failure to position the parts in accordance with these diagrams or failure to use only parts specifically approved with this appliance may result in property damage or personal injury.

**⚠ CAUTION**

Before servicing the burner system ensure that the gas supply is turned OFF and disconnect all electrical connections to the appliance. Allow the appliance to cool to room temperature. Note that the pilot assembly may be hot in an intermittent or standing-pilot system—even if the main burner was never on. Exercise caution when working within the area. ALL WORK SHOULD BE PERFORMED BY A QUALIFIED AND CERTIFIED TECHNICIAN.

Remove glass door assembly and logs (if installed). Be careful with logs as they become fragile after being heated.

Remove log supports from burner assembly. The burner can now be removed.

**TO REMOVE H-BURNER/ORIFICE CHANGE** - Remove the two [2] screws holding the H-Burner in and slide it leftwards off the orifice.

**TO REMOVE ENTIRE BURNER ASSEMBLY**, see below.

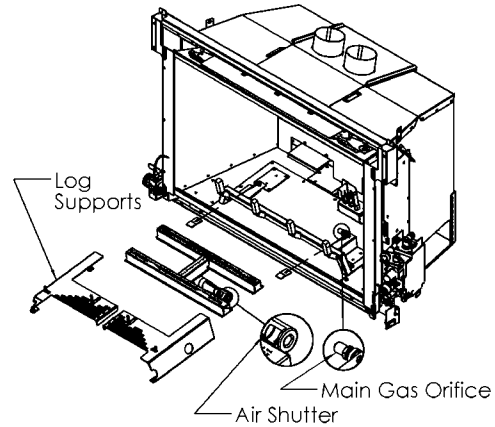

**Step 1:** Disconnect pilot lines and gas supply line from valve on the side of the unit. **NOTE: Care should be taken to ensure that the gas and pilot lines are not damaged during handling. These lines are fragile.**

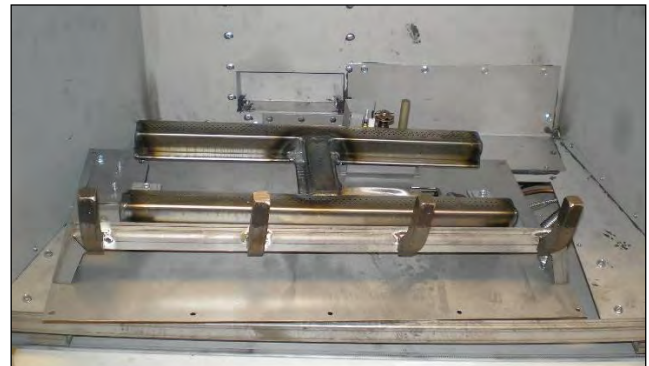

**Step 2:** Locate and remove the twelve [12] screws around the outside of the burner pan. This will remove the entire burner assembly.

To reinstall the burner assembly ensure the surfaces are cleaned, and old sealant material removed. Use high temp Millpac to seal and secure with the twelve [12] screws.

**Pilot Removal**

Disconnect pilot lines from valve as shown above. Remove fan access panel (Not necessary to remove fan) and use this space to draw pilot out from unit.

Installation is the reverse of these steps. Reseal pilot connections to burner pan with orange silicone.

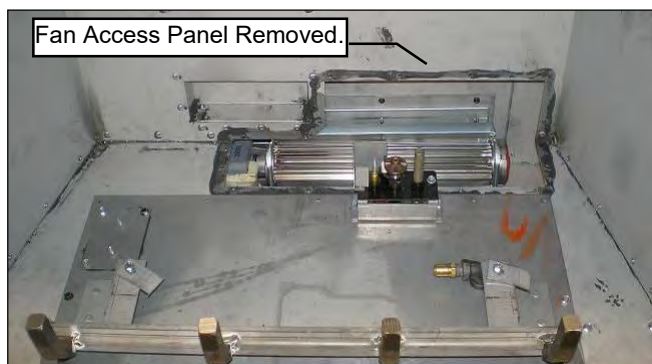
**Valve Removal**

Disconnect pilot lines and gas supply line from valve on the side of the unit. **NOTE: Care should be taken to ensure that the gas and pilot lines are not damaged during handling. These lines are fragile.**

Remove [2] 3/8" nuts holding valve onto Component Plate. Unhook valve from Component Plate.



## IDV26 Clearance to Combustible Mantels

Before installing any mantels it is important to determine the combustibility of its material(s). There are two types of mantel materials to consider: Combustible and Non-combustible.

A Combustible Mantel is one that consists of material(s) that may discolor, combust, or lose its integrity in the presence of heat. These types of mantel must strictly adhere to the dimensional requirements shown in the figures below. Conversely, a Non-combustible Mantel is one that is constructed with materials that can withstand temperatures above 250°F [121°C]. Non-combustible Mantels can be installed at any height above the fireplace opening and thus not restricted to the clearance requires. Check your local codes and regulations to determine whether your mantel is combustible or non-combustible.

Mantel Height From Bottom of Unit	
CV1 / CV2 / CV3	
<b>A</b>	35-3/8"
<b>B</b>	37-3/8"
<b>C</b>	39-3/8"
<b>D</b>	41-3/8"
<b>E</b>	43-3/8"
<b>F</b>	45-3/8"

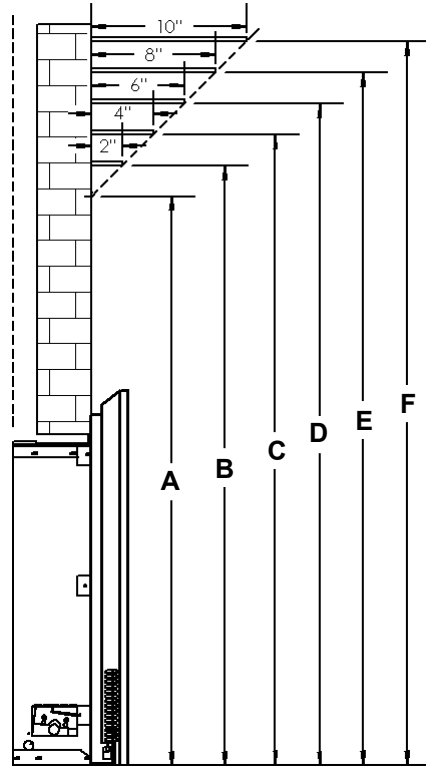

**⚠ WARNING:** Combustible objects must not be placed on a non-combustible mantel unless the non-combustible mantel meets the minimum height and width requirements for a combustible mantel.

**\*To reduce height of Combustible Mantel see Mantel Clearance Shield section.**

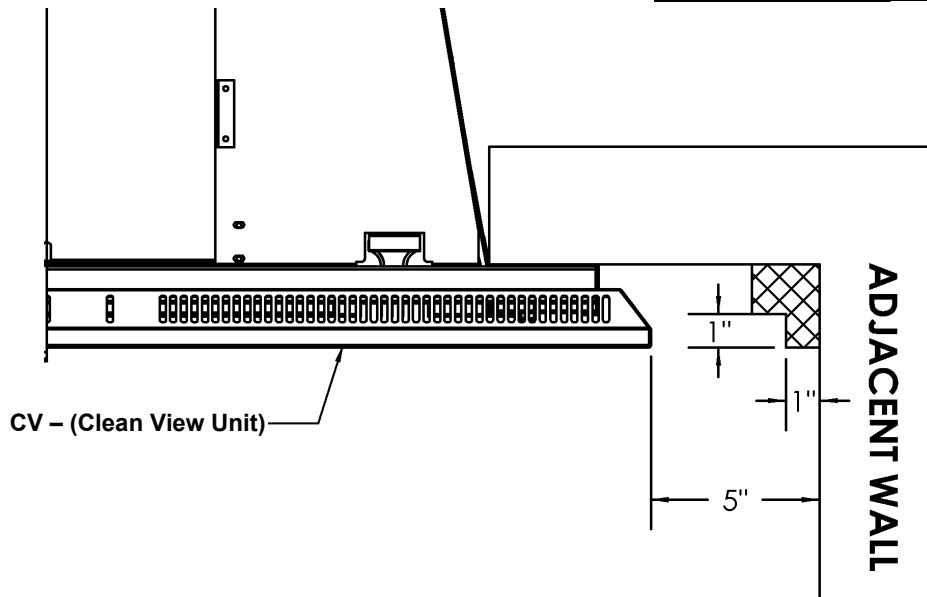



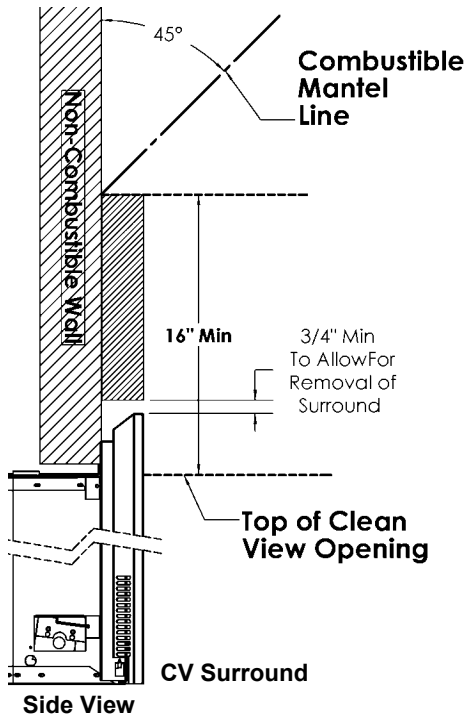

All wall coverings below Combustible Mantel Line **MUST** be Non-Combustible (e.g. steel studs and concrete board).

**\*To reduce height of Combustible Mantel see *Mantel Clearance Shield* section.**

**\*For more information see *Clearance to Combustible Mantels* Page.**

**Required Minimum Hearth**

IDV26 – 3/4" x 12-1/2" x 31" wide

**NOTE: Floor Under Appliance Must Be Non-Combustible**

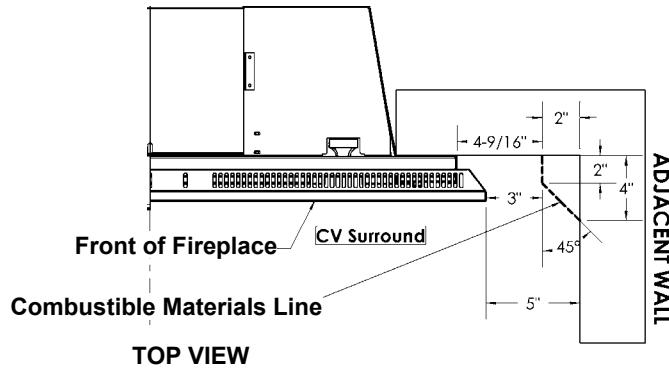

All wall coverings closer than Combustible Materials Line **MUST** be NON-Combustible.

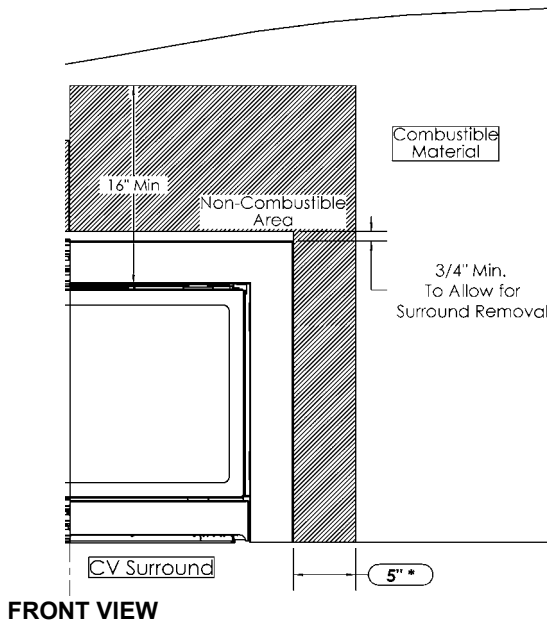

# I33CS -Mantel Clearance Shield- For IDV26 / IDV33 / IDV43

(Must be used with a CV, CV1 or CV3 and a backing Surround.)

**Contents of Kit:** [1] Mantel Clearance Shield c/w Screws

The Mantel Clearance Shield will reduce the required height of a Combustible Mantel by the following amounts:

**IDV26 - 6-7/8"**

**IDV33 - 10-5/8"**

**IDV36 - 10-1/8"**

**IDV43 - 10-1/8"**

See the chart below for required Combustible Mantel height when using the Mantel Clearance Shield.

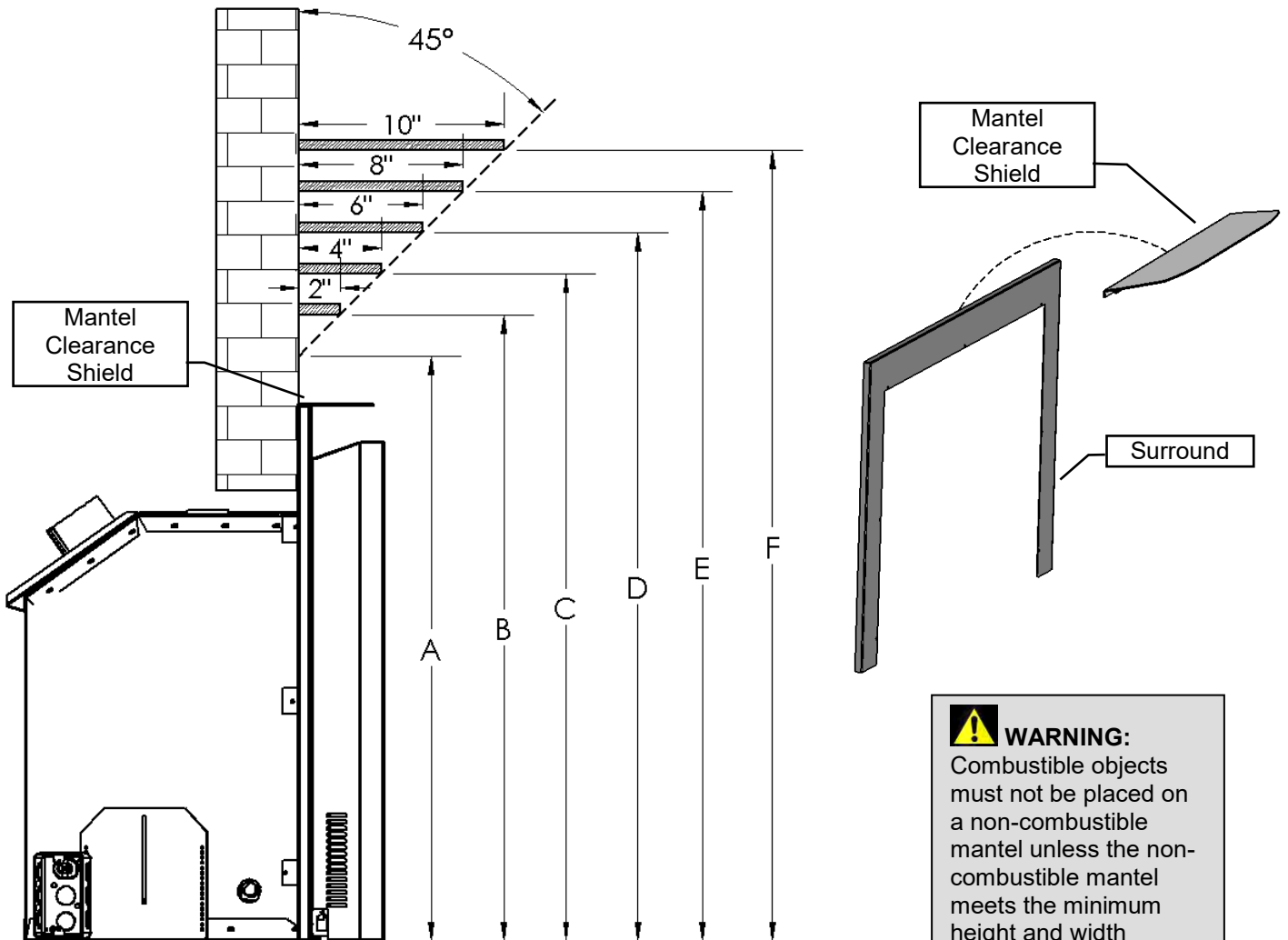

**⚠ WARNING:**  
 Combustible objects must not be placed on a non-combustible mantel unless the non-combustible mantel meets the minimum height and width requirements for a combustible mantel.

Mantel Height From Bottom of Unit (When Using Mantel Clearance Shield)				
	I26CV & I26S1	I33CV & I33SS1	I36CV & I36SS1	I43CV & I43S4432
<b>A</b>	28-1/2"	26-1/4"	34-1/2"	34-1/2"
<b>B</b>	30-1/2"	28-1/4"	36-1/2"	36-1/2"
<b>C</b>	32-1/2"	30-1/4"	38-1/2"	38-1/2"
<b>D</b>	34-1/2"	32-1/4"	40-1/2"	40-1/2"
<b>E</b>	36-1/2"	34-1/4"	42-1/2"	42-1/2"
<b>F</b>	38-1/2"	36-1/4"	44-1/2"	44-1/2"

## I33CS Mantel Clearance Shield Instructions

Contents of Kit: [1] Mantel Clearance Shield c/w Screws

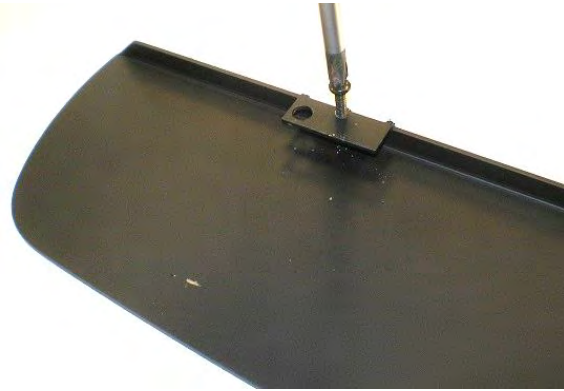
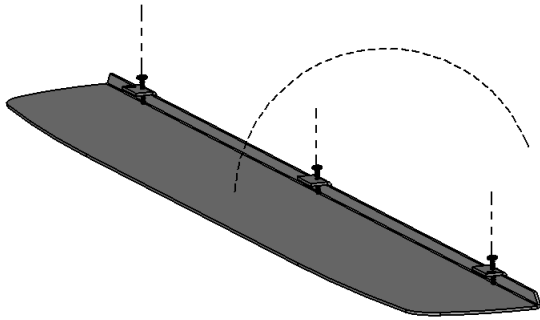

Place I33CS upside down on a protected surface. Loosen screws.

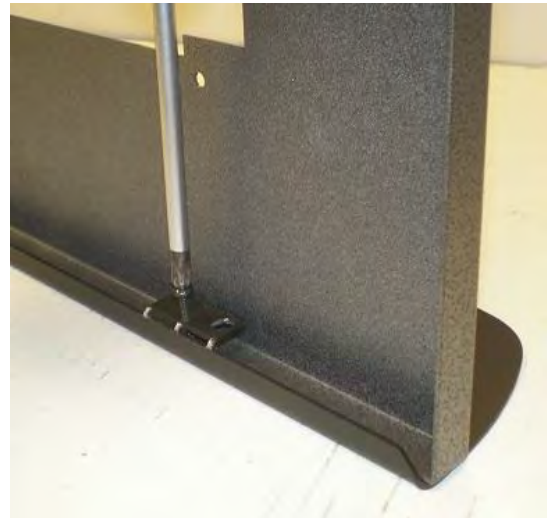
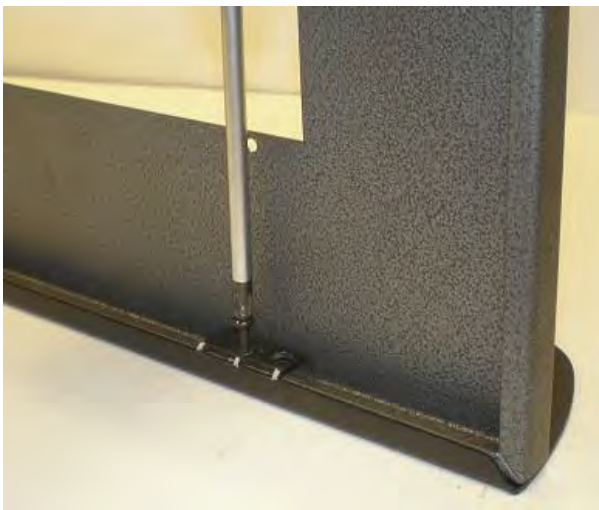

Center surround onto I33CS. Tighten screws to hold surround in place.

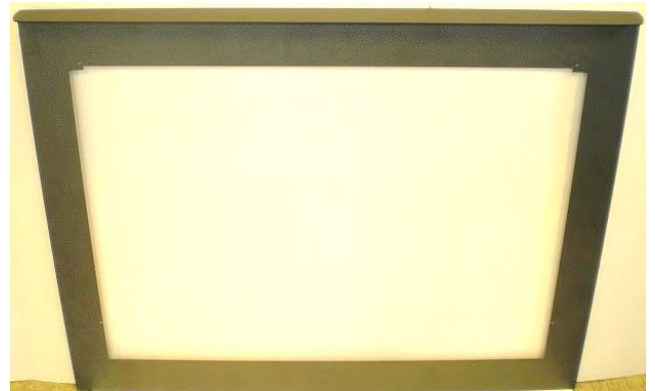

Surround is now ready to install onto fireplace.



## Leveling Instructions

When installing insert it may be necessary to support back of unit.

**IDV26:** There are two leveling legs at the back of the appliance. Remove screws and set to proper height. Replace screws.

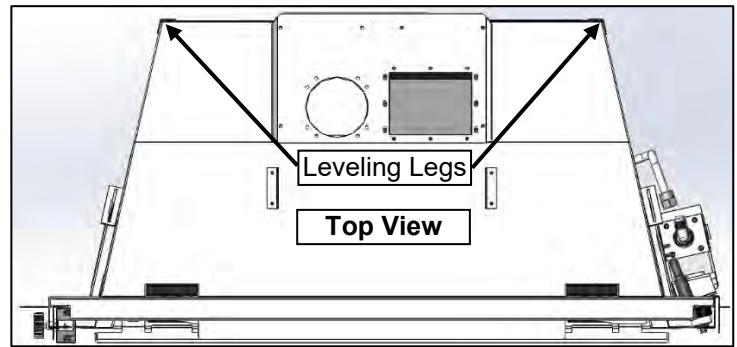
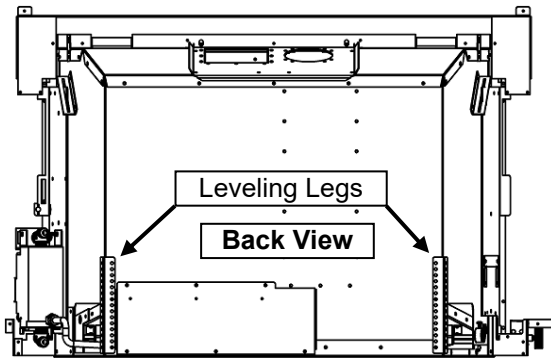

**IDV33 and IDV43:** There are two leveling legs at the front (for Flush Look installations) and two leveling plates at the back sides of the appliance. Remove screws and set to proper height. Replace screws.

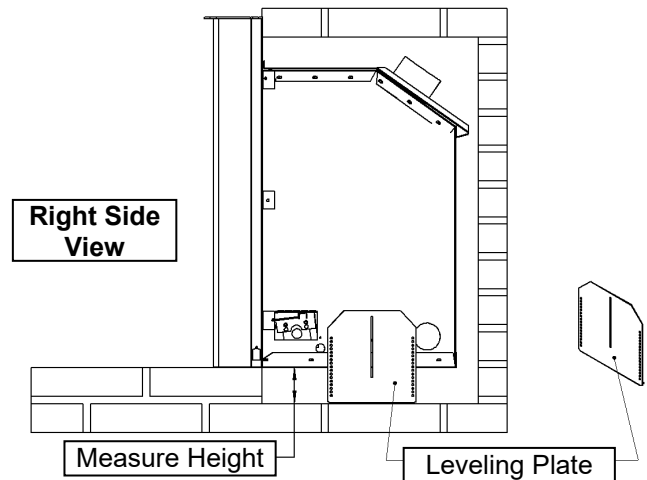
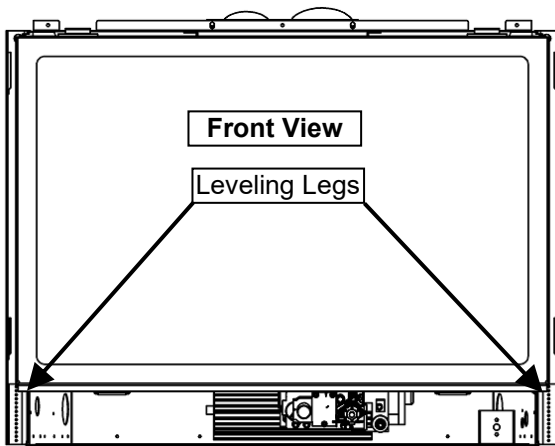

## Riser Kit Installation Instructions – Model No.: I33R40 / I33R44

1. Measure height required to make flush with base of unit (Fig. 1). If measurement is equal to the height of riser kit (2.5"), skip to Step 3. No adjustment will be required.
2. Adjust leveling legs to required height. See Fig. 3 (Detail A).
3. Locate mounting holes punched into base right and left of unit. Place riser assembly under front of insert and fasten to base with supplied screws, Fig. 2.

Fig. 1 - Side view.

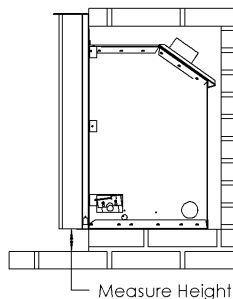
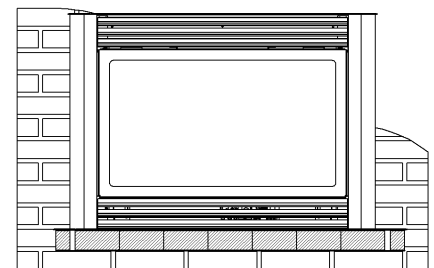

Fig. 2 - Front view with Riser Kit.



**⚠ WARNING:** Failure to position the parts in accordance with these diagrams or failure to use only parts specifically approved with this appliance may result in property damage or personal injury.

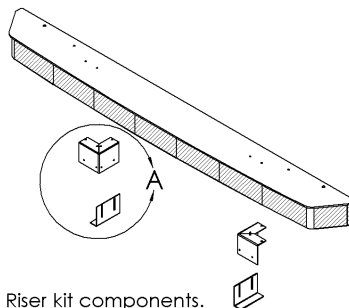
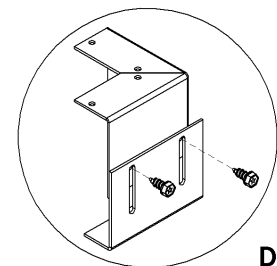

Fig. 3 - Riser kit components.



**DETAIL A**

### Glass Cleaning

It will be necessary to clean the glass periodically. During start-up condensation will form, and cause dust and lint to cling to the surface of the glass. Furthermore, the initial burn cures the paint but also leads to the deposit of a filmy residue. It is therefore recommended that the glass be cleaned two or three times, initially, with non-abrasive common household glass cleansers and warm water. After that, the glass can be cleaned two or three times a season depending on use.

### Warning and Cautions

- Do not clean when the glass is hot.
- Do not use abrasive cleaners.
- Using a substitute glass will void all product warranties.
- Do not strike or abuse glass. Care must be taken to avoid breakage of the glass.
- Do not operate this fireplace without the glass front or with a broken glass.

### REPLACEMENT GLASS

Only Robax ceramic or coated NeoCeram glass may be used for replacement. The glass must be a minimum of 5mm thick.

### Removal of the Glass Door

1. If this unit is a Clean View model then the Clean View Front must first be removed. Please refer to Front Face and Surround Attachment Installation page.
2. Remove the door by unlatching the two [2] top latches. To do so, simply place two fingers in the grooves and pull towards yourself while lifting the latch slightly upwards.
3. Once the top of the door is unlatched, pull it outwards and up to unlatch the bottom.
4. To re-install, place the Bottom Door Ledge into the Lower Latch assembly first. Then swing the door closed to seal it against the firebox cavity. Re-latch the Upper Latch assembly to secure the door to the appliance.
5. To replace glass, clean all materials from door frame. Using a high heat silicone (resistant to 500°F [260°C]) apply a bead of approximately 1/8" to all four sides of frame and insert glass with new gasket. The door frame should be on a flat surface with a small amount of weight pressing the glass into the silicone. Let everything dry for approximately 15 to 20 minutes. The door can be re-installed by following step 4.

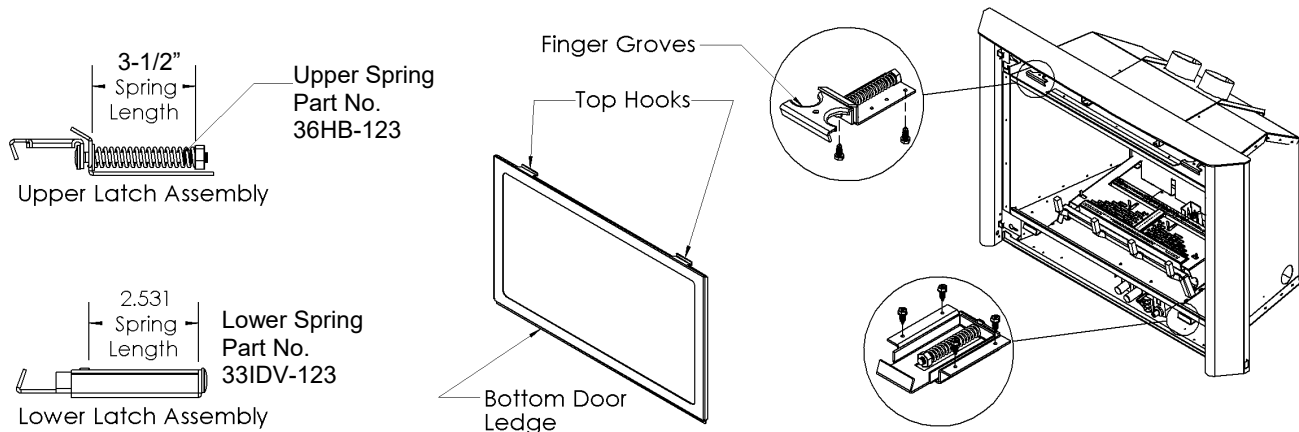

### Spring Replacement

Over time the spring may need to be replaced if tension is lost. Replace spring as follows:

1. Remove the top latches by unfastening the two [2] hex screws that secures it in place. They are located in the firebox.
2. Remove the bottom latches by unfastening the four [4] hex screws located in the firebox (beside the burner assembly). Once the screws are all removed, the latches will either fall or slide out.
3. To remove the spring, unfasten the one [1] lock nut holding it in place. **NOTE: When replacing a spring tighten the lock nut so that the total compression length is 3-1/2". This is critical for proper tension.**



**WARNING: No substitute materials may be used other than factory supplied components.**

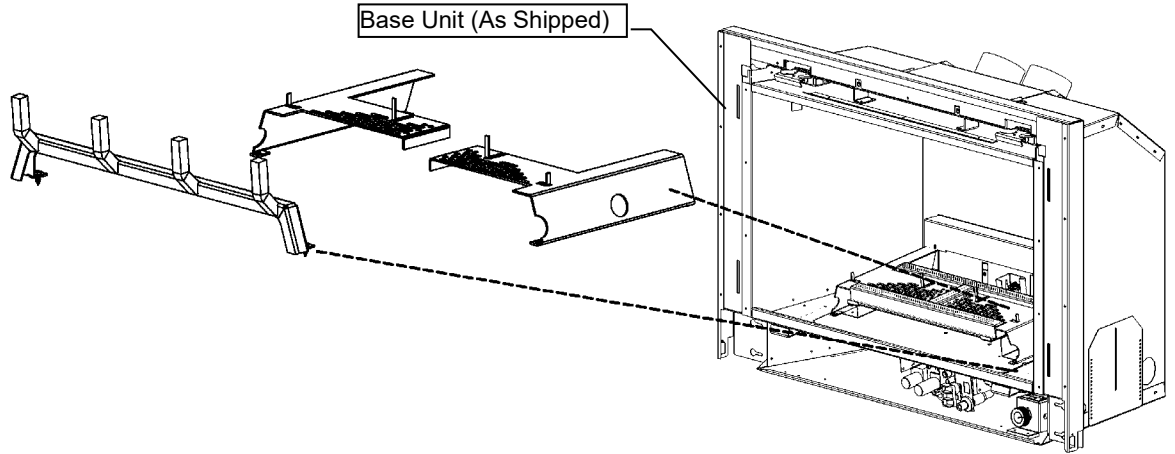

**Preparation:** Remove Grate Bar and replace screws. Remove Ember Plates. Do not remove existing Pilot Shield.

**Installation:** Place MQRSP4 or MQRSP8 over burner.

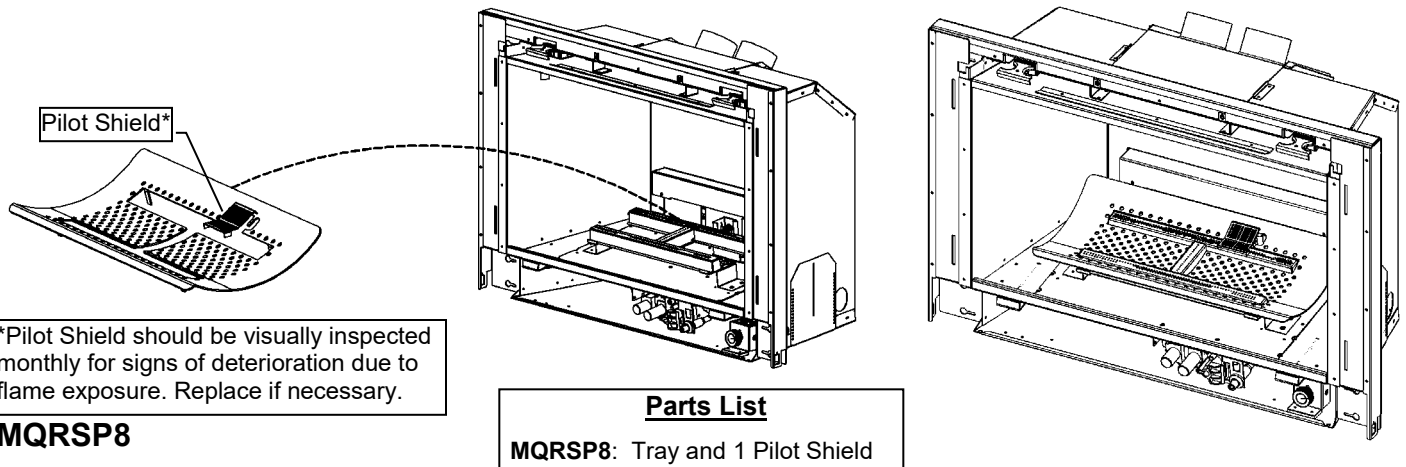
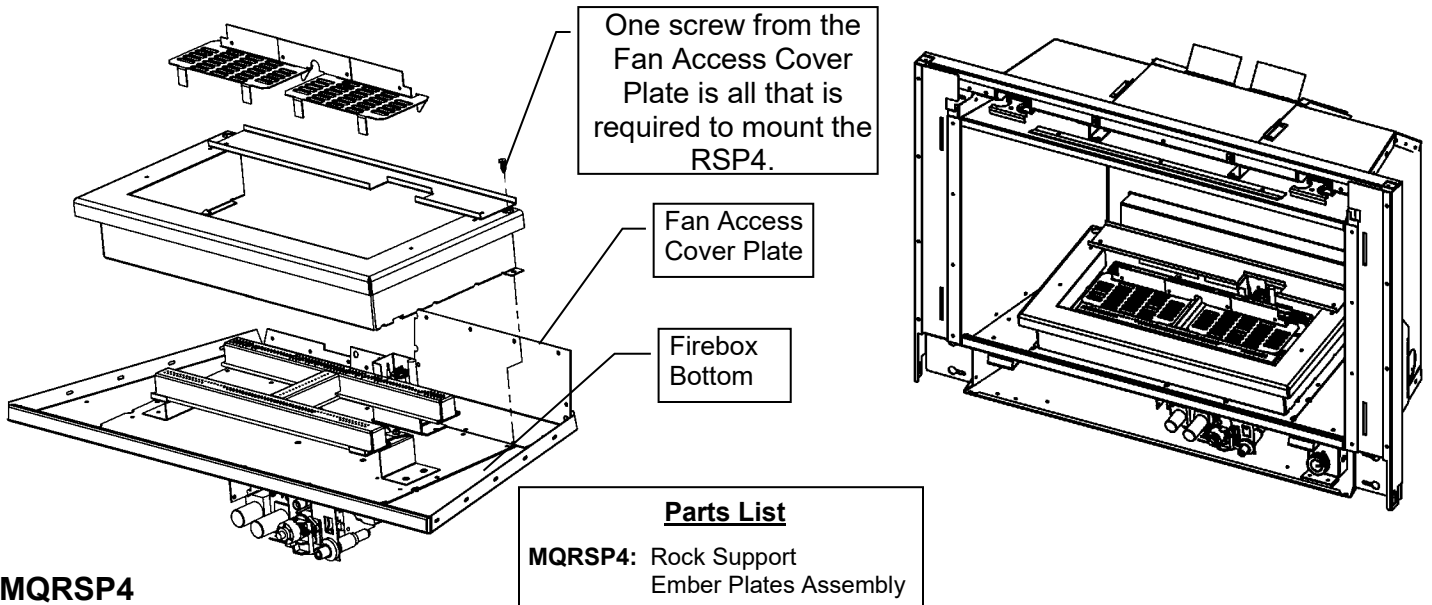



**MQRSP4 Parts List**  
 1Ea Rock Support  
 1Ea Ember Plates Assembly

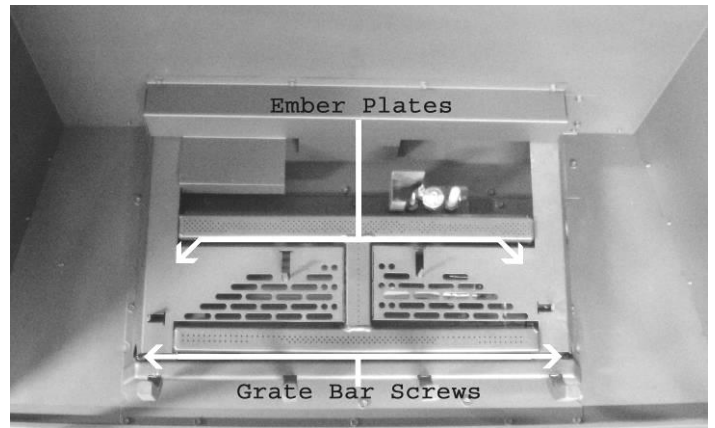

Remove the ember plates and the grate bar by removing the 2 left and right screws on the grate bar. Reinstall screws after removing parts.



Place the MQRSP4 Rock Platform and ember plates into place as shown in the illustration above.

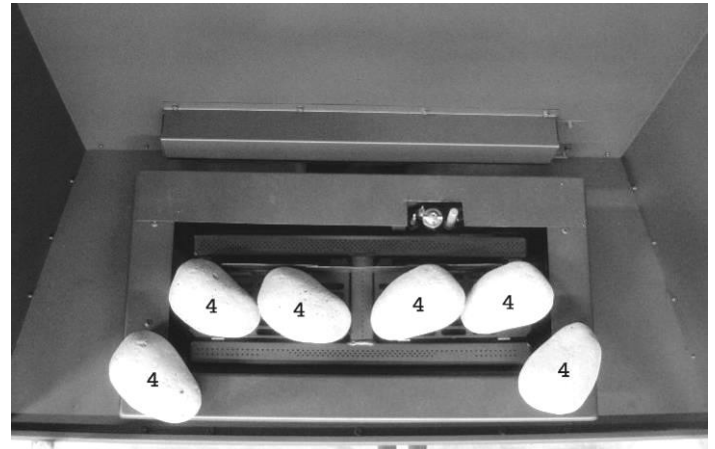

**Step 1:** Place Rocks #4 into position as shown. **Be sure not to place them directly over top of the burner tube.**

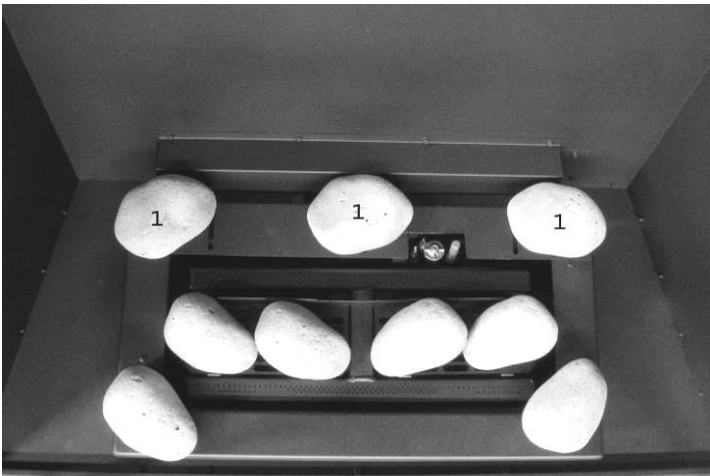

**Step 2:** Place Rocks #1 into position as shown above.

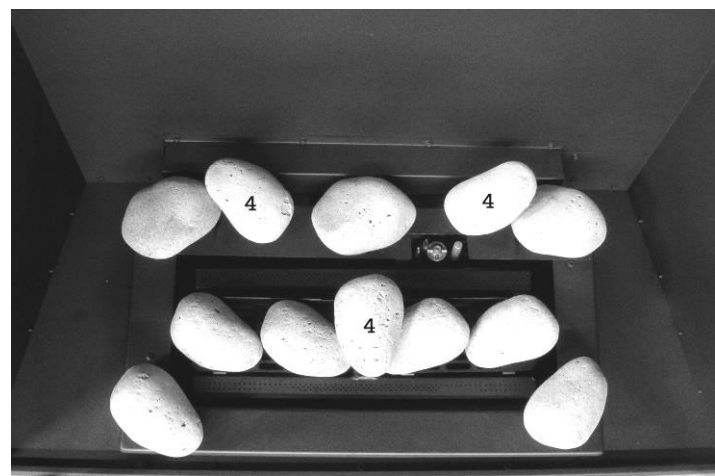

**Step 3:** Place Rocks #4 into position as shown above.

**WARNING:** Failure to position the parts in accordance with these diagrams or failure to use only parts specifically approved with this appliance may result in property damage or personal injury.



**MQROCK2/ MQROCK3 -MQRSP4 for IDV26 / IDV33 / IDV43 (continued)**

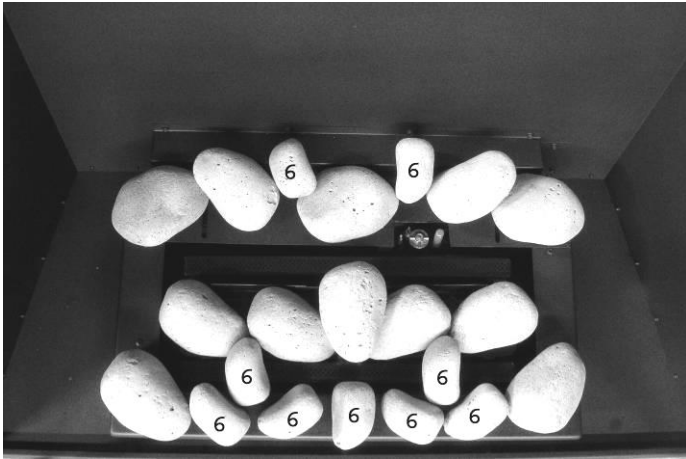

**Step 4:** Place Rocks #6 into position as shown above.

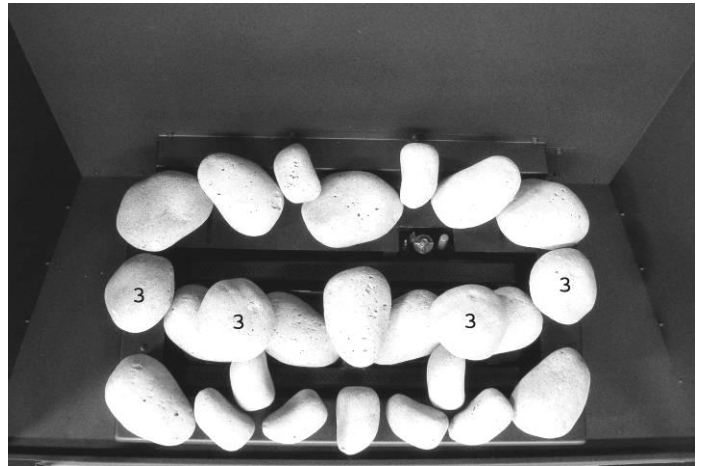

**Step 5:** Place Rocks #3 into position as shown above.

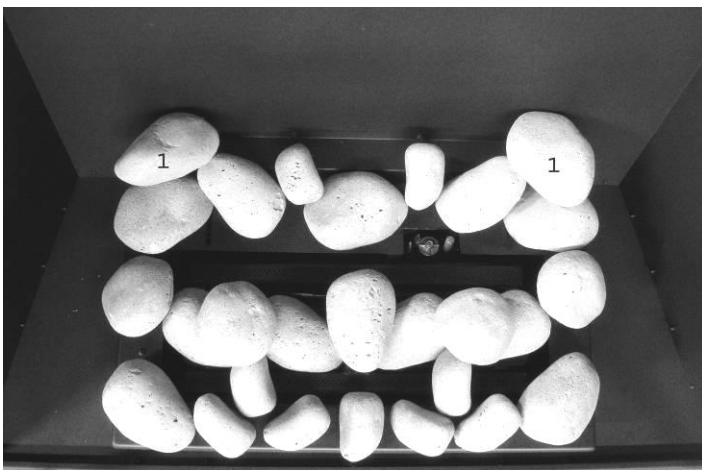

**Step 6:** Place Rocks #1 into position as shown above.



**Step 7:** Place Rocks #3 and #4 into position as shown above.



**Finished Rock Set and Burn**

**NOTE: If flame impingement on the rocks causes sooting then you may have to move, or remove, one or more rocks. DO NOT PLACE ROCKS DIRECTLY OVER TOP OF THE BURNER TUBE.**

Optional Decorative Stone Set.



Begin by placing larger stones inside burner tube area.



Place smaller stones around outside of burner tube.



Cover back and center of burner tube with assorted stones.



Add smaller stones to center.

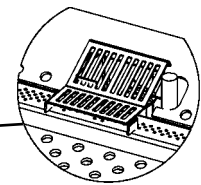

Pilot Area MUST be visible at ALL times.

Do Not stack or overlay when placing on Burner Tube. NOT ALL STONES WILL BE REQUIRED TO FILL TRAY. Spread glass or Lava Rock (supplied with unit) around firebox bottom.

\*Pilot Shield should be visually inspected monthly for signs of deterioration due to flame exposure. Replace if necessary.

**!** Verify ignition of pilot and main burner assembly after setup. Too many rocks over burner ports may cause sooting- remove rocks from over burner ports if this occurs.

**!** **WARNING:** Failure to position the parts in accordance with these diagrams or failure to use only parts specifically approved with this appliance may result in property damage or personal injury.

**MQ DEALER ONLY**

Spread glass or ember chunks onto tray and burner.

Ensure that layer of glass embers is not excessively thick as this will affect the flame pattern. See below.

**! WARNING**

Do not change or substitute the glass ember material provided with this fireplace. If replacing, use only replacement glass embers available from your local authorized dealer.

Pilot Shield\* Must Be Kept Clear.



**MQRSP8**



**RSP10 (With Glass Retainer in Place)**

**Note:** Do not place all the glass embers onto the tray. Only use what is necessary.

Use care when placing glass embers near the pilot area so as not block or have the glass fall over the crossover holes from the pilot to the burner, as delayed ignition can occur.

The following types of glass and other media are approved (Use of any other type other than listed below can alter the performance of the unit and is not covered under warranty.):

**Note:** Use only 1/2" glass material on the burner.

- **1/2" Ember Glass Material from American Fireglass**

Maximum amount for **MQRSP8** Natural Gas is 5 lbs, Propane units 5 lbs.

Maximum amount for **RSP10** Natural Gas is 15 lbs, Propane units 15 lbs.

- **MQ Ember**

Maximum amount for **MQRSP8** is 3 bags.

Not used on **RSP10**.

**Discoloration of glass media may occur . This is not covered under warranty.**

\*Pilot Shield should be visually inspected monthly for signs of deterioration due to flame exposure. Replace if necessary.



**WARNING:** Failure to position the parts in accordance with these diagrams or failure to use only parts specifically approved with this appliance may result in property damage or personal injury.



# RSP10 Glass Support Platform -Installation IDV26 / IDV33 / IDV43

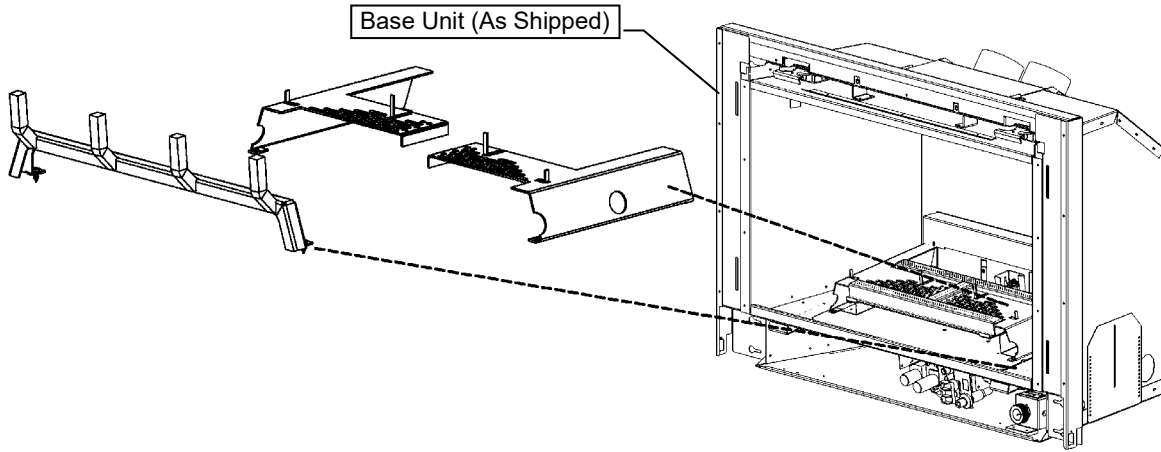

**Preparation:** Remove Grate Bar and replace screws. Remove Ember Plates. Do not remove existing Pilot Shield.

**Installation:** Install RSP10 by placing over burner. Use existing screws at front of firebox bottom to attach Glass Retainer.

## Parts List

**RSP10:** Tray and 1 Pilot Shield\*  
 Glass Retainer 25-1/2" for IDV33  
 Glass Retainer 30" for IDV43  
 15LBS Bronze Glass

\*Pilot Shield should be visually inspected monthly for signs of deterioration due to flame exposure. Replace if necessary.

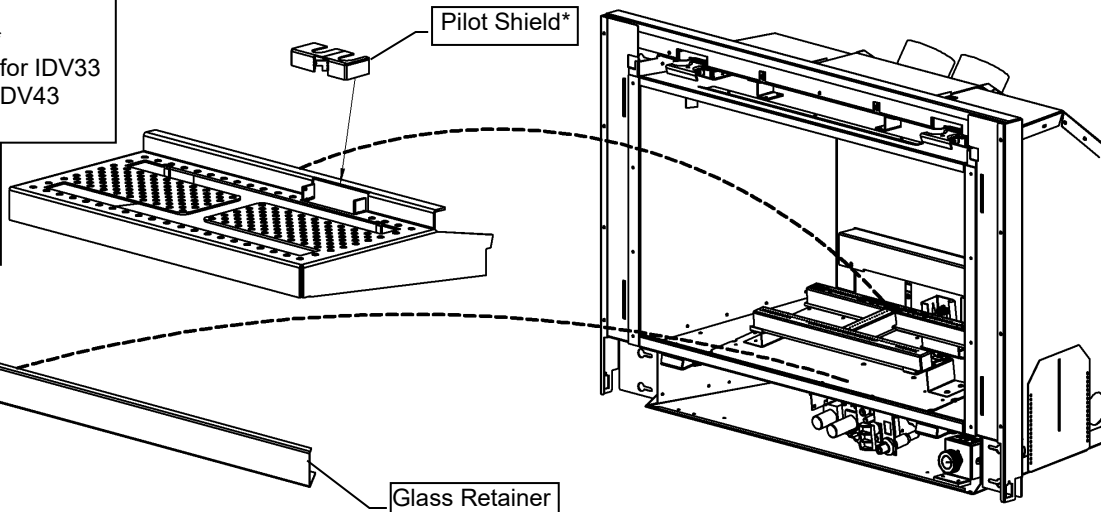

## RSP 10

Use existing screws to attach Glass Retainer.

Lava Rock supplied with unit may be used as a filler beneath Glass Embers on sides of firebox.

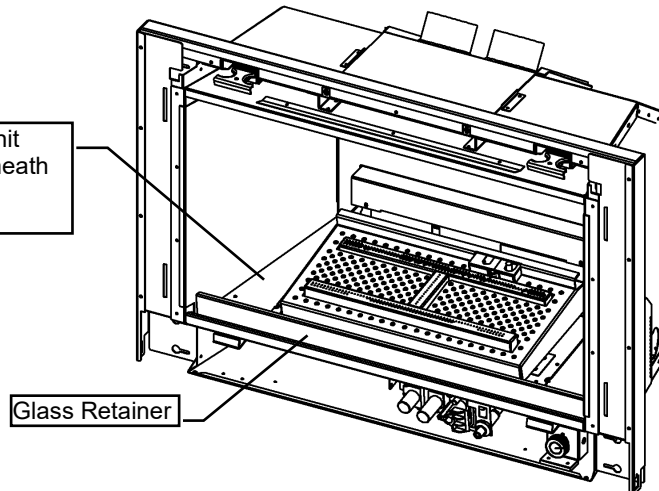

**WARNING:** Failure to position the parts in accordance with these diagrams or failure to use only parts specifically approved with this appliance may result in property damage or personal injury.

Place Glass Embers over tray and on firebox bottom (left and right). Do not cover pilot shield area. See Glass Ember Installation page for further details.



# Millivolt System, Lighting, and Burner Control

## FOR YOUR SAFETY READ BEFORE LIGHTING

**WARNING:** If you do not follow these instructions exactly, a fire or explosion may result causing property damage, personal injury or loss of life.

### BEFORE LIGHTING

- |  |  |
|--|--|
| <p>A This appliance has a pilot which must be lighted by hand. When lighting the pilot, follow these instructions exactly.</p> <p>B Smell all around the appliance area for gas. Be sure to smell next to the floor because some gas is heavier than air and will settle on the floor.</p> | <ul style="list-style-type: none"> <li>• Immediately call your gas supplier from a neighbour's phone. Follow the gas supplier's instructions.</li> <li>• If you cannot reach your gas supplier, call the fire department.</li> </ul> <p>C Use only your hand to push or turn the gas control knob. Never use tools. If the knob will not push in or turn by hand, don't try to repair it. Call a qualified technician. Force or attempted repair may result in a fire or explosion.</p> <p>D Do not use the appliance if any part has been under water. Immediately call a qualified service technician to inspect the appliance and to replace any part of the control system which has been under water.</p> |
|--|--|

### WHAT TO DO IF YOU SMELL GAS

- Do not try to light an appliance.
- Do not touch any electrical switch; do not use any phone in your building.

### LIGHTING INSTRUCTIONS

- |  |   |
|--|---|
| <ol style="list-style-type: none"> <li>1. Stop! Read the safety information above this label.</li> <li>2. Set the thermostat to lowest setting.</li> <li>3. Turn off all electrical power to the appliance.</li> <li>4. Locate valve under the burner assembly.</li> <li>5. If the control knob is not already in the off position, i.e. the word "OFF" in the 9 o'clock position, then push in the gas control knob slightly and turn ⤵ clockwise to "OFF". NOTE: Knob cannot be turned from "PILOT" to "OFF" unless knob is pushed in slightly. Do not use force.</li> <li>6. Wait five [5] minutes to clear out any gas. If you then smell gas. STOP! Follow "B" in the safety information above on this label. If you don't smell gas then go to the next step.</li> <li>7. Now push in the control knob slightly and turn ⤵ counter-clockwise to the "PILOT" position.</li> <li>8. Push in the control knob all the way and hold it. With the other hand push in the red igniter button until you hear a click. Now observe closely the pilot burner located on the rear center-left hand side of the main burner.</li> </ol> | <p>If a flame has appeared then continue to depress the control knob for 20 seconds. If the flame did not appear then continue to depress the red igniter button every 5 seconds until a flame is established. NOTE: If after 30 seconds a flame has not yet been established then turn the control knob back to the off position and repeat steps 5, 6 &amp; 7.</p> <ol style="list-style-type: none"> <li>9. Once the pilot has been established hold the control knob in the depressed position for approximately 25 seconds before releasing. If the flame goes out then repeat steps 7 and 8.             <ul style="list-style-type: none"> <li>• If the knob does not pop up when released, stop and immediately call your service technician or gas supplier.</li> <li>• If the pilot will not stay lit after several tries, turn the gas control to "OFF" and call your service technician.</li> </ul> </li> <li>10. Now turn the control knob to the "ON" position. The burner will not light unless the wall switch thermostat or remote control is turned "ON" or in the case of the thermostat there is a call for heat.</li> <li>11. Close the access door and turn all electrical power back to the appliance.</li> <li>12. The pilot must be turned off when the unit is not in use.</li> </ol> |
|--|---|

### TO TURN OFF THE APPLIANCE

- |  |  |
|--|--|
| <ol style="list-style-type: none"> <li>1. Set the thermostat to lowest setting.</li> <li>2. Turn off all electric power to the appliance if service is to be performed.</li> <li>3. Open the control access door.</li> </ol> | <ol style="list-style-type: none"> <li>4. Push in the gas control knob slightly and turn ⤵ clockwise to the "OFF" position. Do not force.</li> <li>5. Replace control access panel.</li> </ol> |
|--|--|

**NOTE:** Only one on/off device (manual on/off, remote control, or hard wired thermostat) should be connected to the appliance at any one time, this is most important when installing an insert or stove as the on/off rocker switch is installed at the factory.

Recommended Maximum Lead Length (Double Wire)  
When Using Wall Switch or Thermostat

Wire Size	Max. Length
14ga	100ft [30.4m]
16ga	64ft [19.5m]
18ga	40ft [12.1m]
20ga	25ft [7.6m]
22ga	15ft [4.5m]

**CAUTION: DO NOT WIRE 120V POWER TO MILLIVOLT SWITCHES OR THERMOSTAT.**

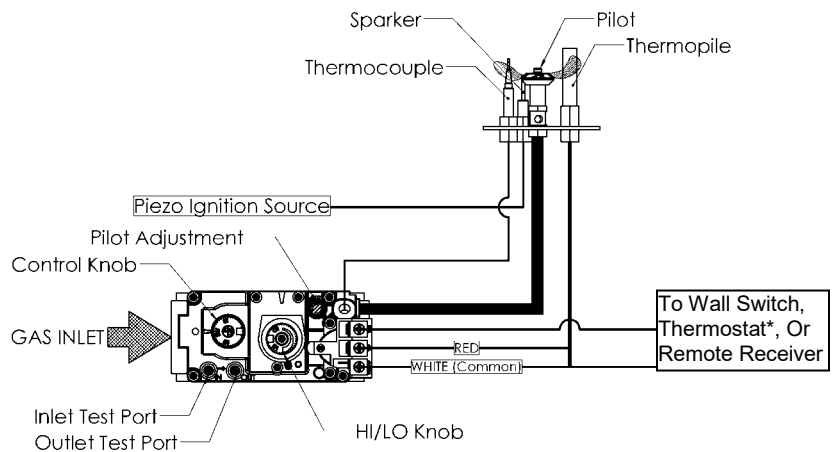

\*In the U.S.A. Thermostats are not permitted for Vented Gas Fireplaces (ANSI Z21.50b-2009 -Decorative).

## Troubleshooting the Gas Control System

### ⚠ WARNING

BEFORE DOING ANY GAS CONTROL SERVICE WORK, REMOVE THE GLASS FRONT.

NOTE: Before troubleshooting the gas control system, be sure external gas shut off is in the "On" position.

Problem	Possible Causes	Corrective Action
Spark igniter will not light.	Defective or misaligned electrode at pilot.	Check for spark at electrode and pilot: if no spark and electrode wire is properly connected, replace igniter.
	Defective igniter (push-button).	Using a match, light pilot. If pilot lights, turn off pilot and push the red button again. If pilot will not light - check gap at electrode and pilot should be 1/8" to 1/4" to have a strong spark.
Pilot will not stay lit after carefully following lighting instructions.	Defective thermocouple (flame switch where applicable).	Check pilot flame. Must impinge on generator and thermocouple. Clean and/or adjust pilot for maximum flame impingement on generator and thermocouple. Replace thermocouple if pilot will not hold. (Hand tight 1/8 turn on replacement)
	Defective valve magnet.	Replace valve, if pilot won't hold after the thermocouple is replaced.
Pilot burning, no gas to burner, valve knob "ON", and wall switch "ON".	Wall switch or wires defective.	Check wall switch and wires for proper connections. Jumper wire across terminals at wall switch. If burner comes on, replace defective wall switch. If okay, jumper wires, across wall switch wires at valve. If burner comes on, wires are faulty or connections are bad.
	Generator may not be generating sufficient voltage.	Check generator with millivolt meter. Take reading at generator terminals of gas valve. Should read 325 millivolts minimum while holding valve knob depressed in pilot position and wall switch "off" Replace faulty generator if reading is below specified minimum.
	Plugged burner orifice.	Check burner orifice for stoppage and remove.
	Defective automatic valve operator.	Remove wall switch wires from gas valve. Install jumper wires from top bottom terminals of gas valve. Turn valve on "ON". If main burner does not light, replace valve.
Frequent pilot outage problem.	Pilot flame may be too low or blowing (high) causing the pilot safety to drop out.	Clean and/or adjust pilot flame for maximum flame impingement on generator and thermocouple. *See NOTE below – Seven Day Timer
Flame lifts off burner and goes out in less than 30 seconds.	Inner 4" liner has come off flue or termination, flame is starving for oxygen.	Attach 4" liner to flue or termination using screws, silicone and clamps as stated in manual.
Flame lifts off burner on one side while the rest of the flame remains lit.	Improper installation of firebrick. Firebrick is likely leaning.	Be sure to position firebrick against firebox walls and be sure to use brick clips attached to the inner side of firebox.

**\*NOTE:** The pilot system for this appliance may be equipped with a **Seven Day Timer**, in which case the pilot flame will be extinguished if the main burner has not been turned ON for seven days.

This Seven Day Cycle is reset every time the main burner is cycled ON / OFF and the pilot remains lit.

If more than seven days has passed since the main burner has been cycled ON / OFF and the pilot is also out, follow the procedures described in this manual to light the pilot.

**NOTE: MILLIVOLT UNITS WITH 7 DAY TIMER** – When lighting pilot, the Pilot Knob must be pressed until a **BEEP** is heard. This procedure may take up to **TWO MINUTES**.

# Gas Line Installation

This gas appliance should be installed by a qualified installer in accordance with local building codes and with current CAN/CSA - B149.1 installation codes for Gas Burning appliances and equipment in Canada and the National Fuel Gas Code ANSI Z223 in the U.S.A.

## State of Massachusetts

For the state of Massachusetts a T-handle gas shut-off valve must be used on a gas appliance. This T-handle gas shut-off valve must be listed and approved by the state of Massachusetts. This is in reference to the state of Massachusetts state code CMR238.

1. The gas pipeline can be brought in through either the right or left side of the appliance. Knockouts are provided at these locations to allow for the gas pipe installation and testing of any gas connection.
2. The gas control inlet is 3/8" NPT. Typical installation layout for rigid pipe is shown at right.
3. When using copper or flex connector, use only approved fittings. Always provide a union so that gas line can be easily disconnected for burner or fan servicing. See gas specification for pressure details and ratings.
4. When a vertical section of gas pipe is required for the installation, a condensation trap is needed. See CAN/CSA-B149.1 for code details.
5. For natural gas, a minimum of 3/8" iron pipe with gas minimum pressure of 5.5" w.c. must be used for supply from the gas meter. Consult with the local gas utility if any questions arise concerning pipe sizes.
6. Ports are accessible for test gauge connection both on the inlet and outlet of the gas valve.
7. Turn the gas supply ON and check for leaks. **DO NOT USE OPEN FLAME FOR THIS PURPOSE.** Use an approved leak testing solution.
8. The appliance and its individual shutoff valve must be disconnected from the gas supply piping system during any pressure testing of that system at test pressures in excess of 1/2psig [3.5 kPa].
9. The appliance must be isolated from the gas supply piping system by closing its individual shutoff valve during any pressure testing of the gas supply piping system at test pressures equal to or less than 1/2psig [3.5 kPa].

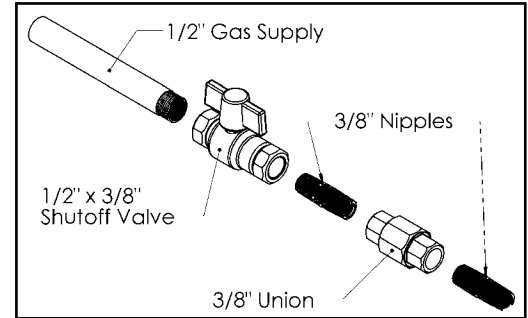

Shutoff valves installed in tubing systems shall be rigidly and securely supported independently of the tubing.

Note: The gas line connection may be made of 1/2" rigid pipe, 1/2" copper pipe or an approved flex connector. Since some municipalities have additional local codes, it is always best to consult your local authorities and the current CAN/CSA - B149.1 installation code in Canada or the National Fuel Gas code ANSI Z223.1 in the U.S.A.

**IMPORTANT: Check for gas leaks with a soap and water solution. DO NOT USE OPEN FLAME FOR LEAK TESTING.**

Models	IDV26N/NE/2	IDV26LP/LPE/2	IDV33N/NE/2	IDV33LP/LPE/2	IDV43N/NE/2	IDV43LP/LPE/2
<b>Fuel</b>	Natural Gas	Propane	Natural Gas	Propane	Natural Gas	Propane
<b>Gas Control</b>	Millivolt Adjustable					
<b>Maximum Input [BTU]</b>	28,500 HI 19,500 LO	28,000 HI 23,000 LO	31,000 HI 20,900 LO	28,500 HI 23,100 LO	34,250 HI 24,860 LO	30,030 HI 22,840 LO
<b>Orifice Size (0-4500ft)</b>	#37	#52	#35	#51	#32	#50
<b>Air Shutter</b>	3/16"	Fully Open	3/16"	1/2"	3/16"	1/2"
<b>Gas Inlet Size</b>	S.I.T. 820 Nova, 3/8" NPT					
<b>Gas Supply Pressure</b>	<b>Minimum</b>			<b>Normal</b>		<b>Maximum</b>
<b>Natural Gas</b>	4.5"			7"		9"
<b>Liquid Propane</b>	11"			11"		12"
<b>Manifold Pressure High</b>	3.5" w.c. [0.87kPa] <b>NG</b>			10" w.c. [2.61kPa] <b>LP</b>		
<b>Manifold Pressure Low</b>	1.6" w.c. [0.40kPa]			6.3" w.c. [1.57kPa]		

# Annual Inspection List for Determining Safe Operation of a Direct Vent Gas Fireplace

Refer to this checklist for proper maintenance, safe use, and operation.

See each section for more specific information.

1. Inspect and operate all pressure relief mechanisms (i.e., relief dampers, spring loaded door latches) installed on your appliance to verify relief mechanisms are free from obstruction to operate.

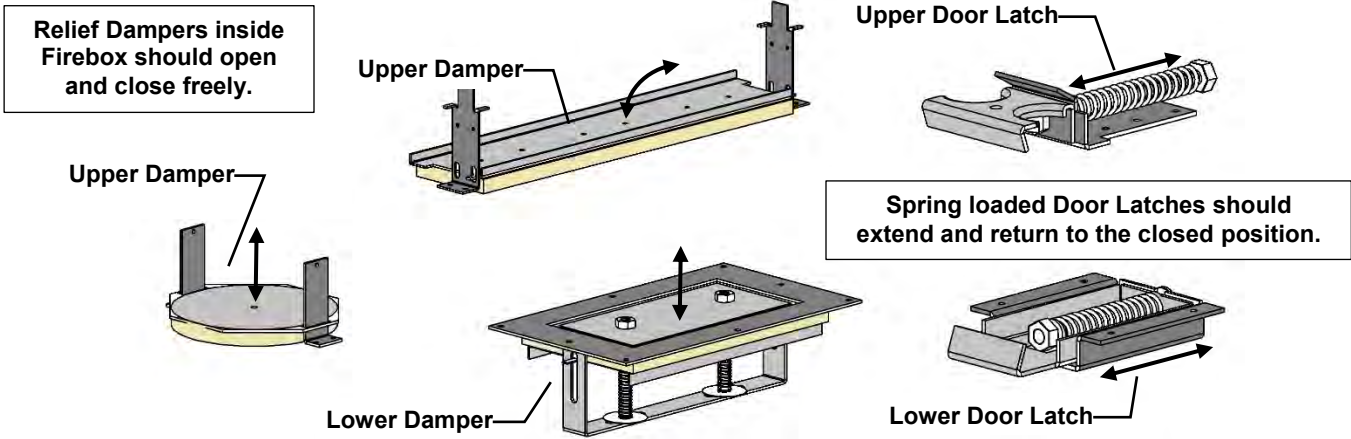

2. Clean glass window with a suitable fireplace glass cleaner. Abrasive cleaners must not be used. Be careful not to scratch the glass when cleaning.

3. Inspect the operation of the Pilot. Ensure that it is working properly.

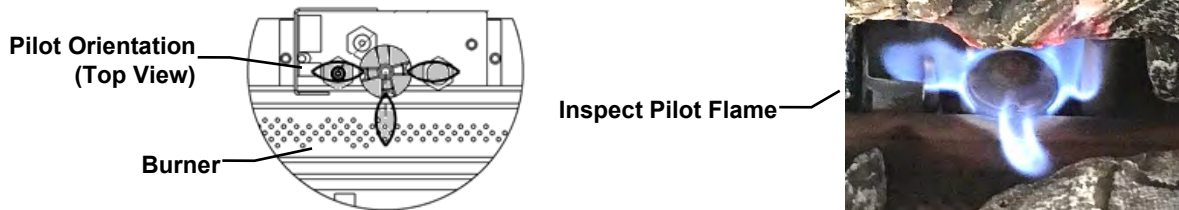

4. Inspect and ensure the lighting of the main burner occurs within 4 seconds of the main gas valve opening. Visual inspection should match that outlined in the appliance instruction manual (refer to **Monthly Flame Inspection**). Inspect primary air openings for blockage.

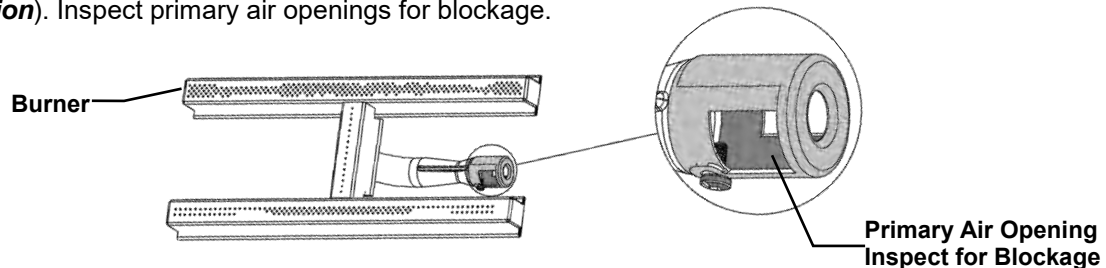

5. Inspect condition of vent and vent terminal for sooting or obstruction and correct if present.
6. Vacuum and clean any debris in the firebox that is not supposed to be there.
7. Test and measure the flame failure response time of the flame safety system. It must de-energize the safety shutoff in no more than 30 seconds.
 

**Procedure for Millivolt Units:** Turn on fireplace for 5 minutes. Shut off fireplace while listening to valve. A "click" should be heard within 30 seconds. This indicates the safety shutoff is working properly.

**Procedure for IPI Units:** Turn on fireplace and allow main burner to come on. Then disconnect Flame Sense wire from IPI Module (X3 Connection). The fireplace should shut down immediately.
8. Check all accessible gas-carrying tubes, connections, pipes and other components for leaks.



## Burner System Maintenance

It is recommended to annually inspect and clean the Burner System to prevent malfunction and / or sooting. This operation should be performed by your dealer or a qualified technician.

### ! -CAUTION-

Before servicing the burner system ensure that the gas supply is turned OFF and disconnect all electrical connections to the appliance. Allow the appliance to cool to room temperature. Note that the pilot assembly may be hot in an intermittent or standing-pilot system—even if the main burner was never on. Exercise caution when working within the area.

**-ALL WORK SHOULD BE PERFORMED BY A QUALIFIED AND CERTIFIED TECHNICIAN-**

### Monthly Flame Inspection

It is recommended to turn on the unit at least once a month and inspect the flame pattern to ensure there are no problems with the burner tube. The pilot flame should also be inspected monthly to ensure proper operation.



Flame should appear similar to the above picture.

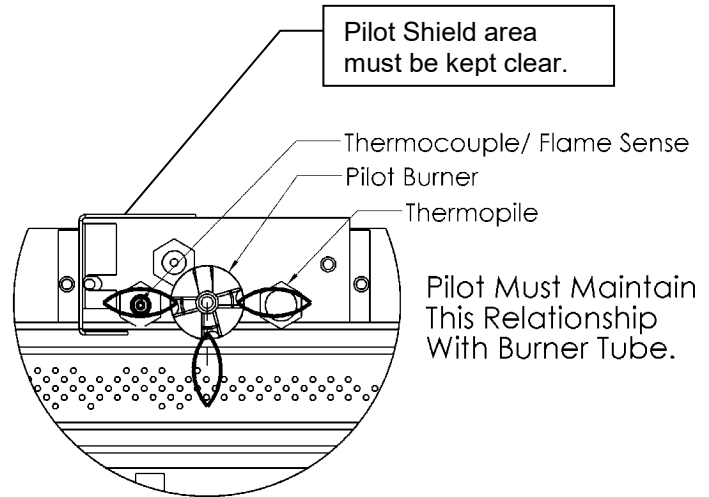

## Conversion Kit Instructions – PART A

Kit Number	Description	Pilot Orifice	Burner Orifice Brass (1000-255)	Brass Nipple	Air Shutter	Hi/Lo Regulator
26IDV-CKLP 33IDV-CKLP 43IDV-CKLP	LP Conversion -Millivolt-	1001-P167SI <b>#30</b> (977.167)	#52 #51 #50	1000-253closed 1000-253closed 1000-253closed	Fully Open 1/2" 1/2"	1001-P202SI 1001-P202SI 1001-P202SI
26IDV-CKNG 33IDV-CKNG 43IDV-CKNG	NG Conversion -Millivolt-	1001-P165SI <b>#51</b> (977.165)	#37 #35 #32	1000-253closed 1000-253closed 1000-253closed	3/16" 3/16" 3/16"	1001-P201SI 1001-P201SI 1001-P201SI
26IDV-CKLPI 26IDV-CKLP2 33IDV-CKLPI 33IDV-CKLP2 43IDV-CKLPI 43IDV-CKLP2	LP Conversion -IPI-	1001-P168SI <b>#35</b> (977.168)	#52 #52 #51 #51 #50 #50	1000-253closed 1000-253closed 1000-253closed 1000-253closed 1000-253closed 1000-253closed	Fully Open Fully Open 1/2" 1/2" 1/2" 1/2"	1002-P014SI 1002-P012SI 1002-P014SI 1002-P012SI 1002-P014SI 1002-P012SI
26IDV-CKNGI 26IDV-CKNG2 33IDV-CKNGI 33IDV-CKNG2 43IDV-CKNGI 43IDV-CKNG2	NG Conversion -IPI-	1001-P166SI <b>#62</b> (977.166)	#37 #37 #35 #35 #32 #32	1000-253closed 1000-253closed 1000-253closed 1000-253closed 1000-253closed 1000-253closed	3/16" 3/16" 3/16" 3/16" 3/16" 3/16"	1002-P016SI 1002-P013SI 1002-P016SI 1002-P013SI 1002-P016SI 1002-P013SI

Refer to "Gas Specifications Chart" for inlet pressures and input ratings. Clock meter to verify input rate. Place conversion label as close to converted gas control as possible. Refer to lighting instructions to verify the normal operating sequence of the ignition system. IMPORTANT: Always check for gas leaks with a soap and water solution. DO NOT USE OPEN FLAME FOR LEAK TESTING.

## Conversion Kit Instructions – PART A

### Caution:

The gas supply shall be shut off prior to disconnecting the electrical power, before proceeding with the conversion.

PLEASE CONFIRM THAT STEP 4 IS UNDERSTOOD BEFORE PROCEEDING WITH CONVERSION.

 **WARNING:** This conversion kit shall be installed by a qualified service agency in accordance with the manufacturer's instructions and all applicable codes and requirements of the authority having jurisdiction. If the information in these instructions is not followed exactly, a fire, explosion or production of carbon monoxide may result causing property damage, personal injury or loss of life. The qualified service agency is responsible for the proper installation of this kit. The installation is not proper and complete until the operation of the converted appliance is checked as specified in the manufacturer's instructions supplied with the kit.

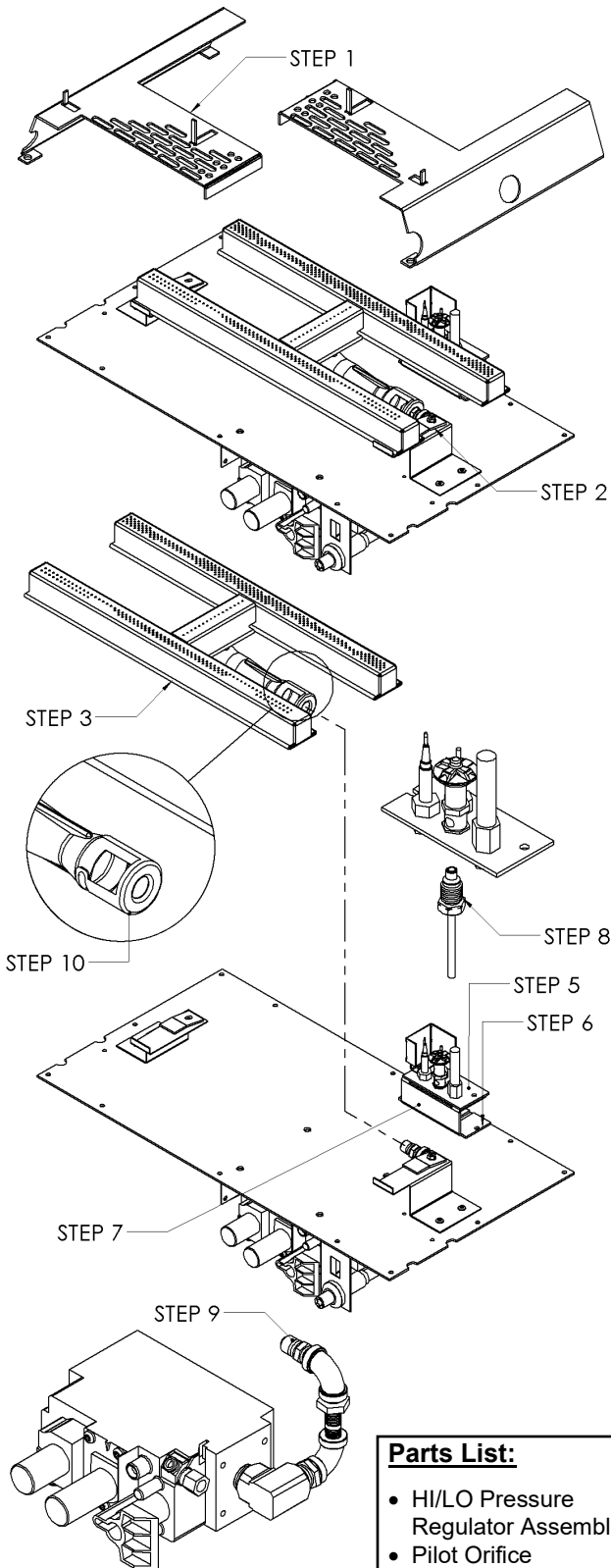

1. Remove the 2 ember plates from the burner. This step may not be required, depending on the type of burner assembly.
2. Loosen the 2 screws holding the burner in place.
3. Slide the burner to the left to expose the orifice.
4. **Before going any further you need to verify which pilot system is in use. If there is a spring clip below the pilot hood then proceed to STEP 5 in PART B.**
5. Remove the 2 screws that hold the pilot to the bracket.
6. Remove the 2 screws that attach the pilot bracket to the firebox bottom.
7. Remove the pilot bracket to expose the pilot assembly.
8. Remove the pilot tube and nut from the pilot assembly using a 10mm wrench; slide the tube and nut down. You may have to tap the pilot hood lightly to release the pilot orifice. Place new pilot orifice into the pilot assembly and reinstall the pilot tube and nut. Tighten with wrench. Reinstall pilot bracket at this time.
9. Remove main orifice using a 1/2" wrench and replace with new conversion orifice.
10. Adjust the primary air setting to the correct setting as specified in the manual or label plate. To adjust the air setting, loosen the screw on the side of the tube and rotate to the correct opening using a drill bit or tape measure. Retighten screw. Reinstall burner at this time reversing STEPS 3, 2 and 1.
11. Follow instructions supplied with the conversion HI/LO to convert the valve from one type of fuel to the other.
12. Check for gas leaks around the pilot burner tube and face of valve.
13. Attach conversion label to label plate on bottom of unit, writing information as needed.

### Parts List:

- HI/LO Pressure Regulator Assembly
- Pilot Orifice
- Burner Orifice
- Brass Nipple
- Instructions
- Conversion Kit Label



Instructions for converting SIT 190 series pilot burner injector from NG to PROPANE and from PROPANE to NG only. This information should be considered as supplemental to the Appliance Manufacturer's Instructions.

**WARNING! The installation of this conversion kit must only be undertaken by a qualified and certified gas appliance installer.**

1. Shut-off the gas supply to the appliance.
2. Allow the pilot burner to cool to room temperature.

**WARNING: Touching a hot pilot burner can result in injury.**

3. The pilot hood is held in place by spring. First remove the spring, then remove the hood by pulling it up from the pilot bracket (fig. 1).
4. Insert a 5/32" or 4 mm Allen wrench into the hexagonal key-way of the injector (fig. 2), and rotate it counter-clockwise until it is free of the injector journal.
5. Verify that the new injector is proper for the application. The injector size is stamped on the side of the injector near the top. Propane injectors have a groove machined around their circumference near the top, while NG injectors do not have a groove (fig. 4). Refer to the Appliance Manufacturer's instruction sheet for the proper injector size.
6. Insert the Allen wrench into the end of the injector. Then, insert the injector into injector journal, and rotate the injector clockwise until a torque of 9 lbf in (1.0 Nm) is achieved.
7. First replace the pilot hood by aligning the tab on the base of the hood with the slot in the side of the pilot journal, and push the hood down, onto the pilot bracket (fig. 3). The hood must sit squarely on the bracket for proper operation. Then replace the spring by pushing it on his seat (fig.3). Check to insure that the hood is properly seated onto the pilot bracket and that the spring is properly inserted onto his seat.
8. Restore the gas supply to the appliance, and ignite the pilot burner. Verify proper ignition and operation.



fig. 1

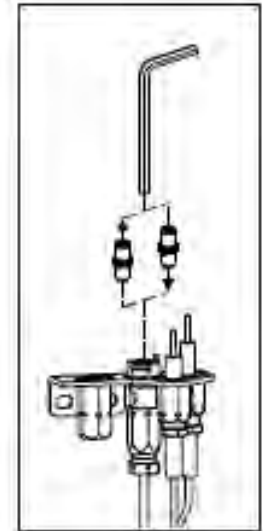

fig. 2

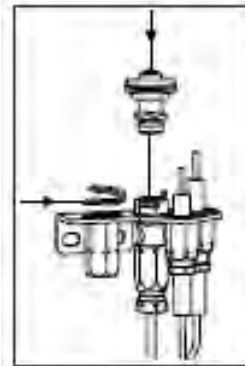

fig. 3

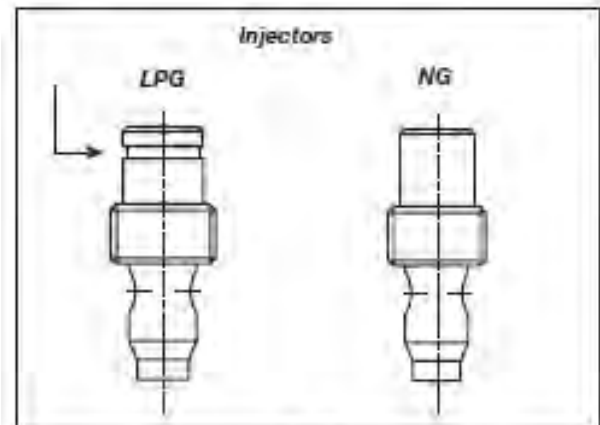

fig. 4

## WARNING!

This conversion kit must **ONLY** be applied as part of a conversion kit supplied by the **APPLIANCE MANUFACTURER** for the specific appliance, and type of gas, being converted.



# SIT GROUP

www.sitgroup.it

7.252.136

# installation instructions

## 820 NOVA mV

### Modulating Conversion Kit



**WARNING!**

The installation of this conversion kit must only be undertaken by a qualified and certified gas appliance installer.

**MODULATING PRESSURE REGULATOR CONVERSION KIT INSTALLATION OR REPLACEMENT INSTRUCTIONS.**

- 1 Turn control knob to the OFF position, and shut off the gas supply to the valve.
- 2 Using a Torx T20, or slotted screwdriver, remove and discard the three pressure regulator mounting screws (A), pressure regulator tower (B), and the spring and diaphragm assembly (C).  
(If applicable)
- 3 Insure that the rubber gasket (D) is properly positioned and install the new modulating pressure regulator assembly to the valve using the new screws (E) supplied with the kit. Tighten screws securely.  
(Reference torque = 25 In.Lb.)
- 4 Install the enclosed identification label (F) to the valve body where it can be easily seen.
- 5 Apply gas to system and re-light appliance according to manufacturers instructions.
- 6 With the main burner "ON", test the new pressure regulator assembly for leaks using a soap solution.
- 7 Relight the main burner in both the HI and LO positions, and verify proper burner ignition and operation.

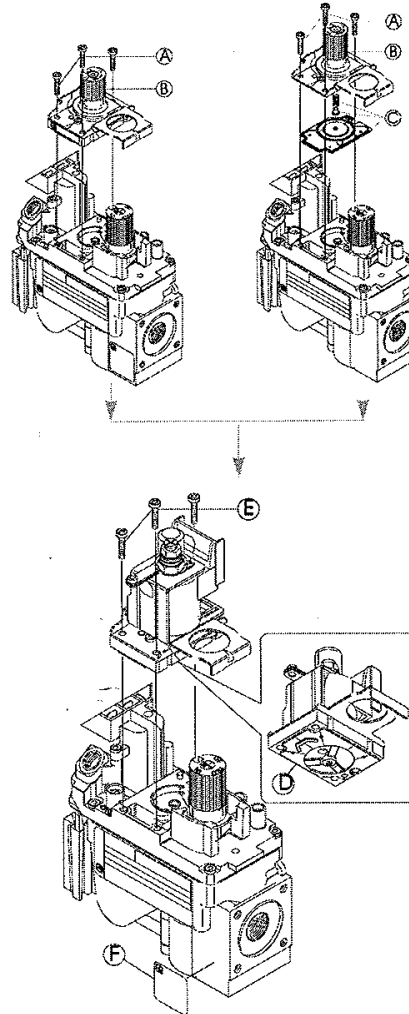

**WARNING!**

This modulating conversion kit must ONLY be applied as part of a conversion kit supplied by the APPLIANCE MANUFACTURER for the specific appliance, and type of gas, being converted.

**INSTALLER NOTICE.** These instructions must be left with appliance.



**SIT Group**



## IPI Proflame 1 -Remote Control Operation-

The Proflame GTM is configured to control the on/off main burner operation, its flame levels, and provides on/off and Smart \*thermostatic control of the appliance.

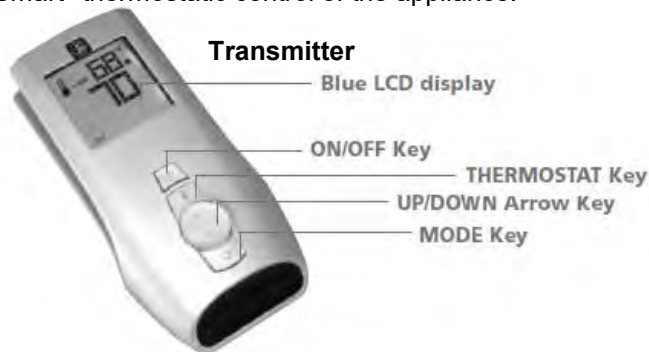

### Transmitter

The Transmitter is powered by 3 AAA type batteries. A Mode Key is provided to Index between the features and a \*thermostat Key is used to turn on/off or index through \*thermostat functions

### Remote Receiver

The Receiver connects directly to the gas valve and stepper motor with a wiring harness. The Receiver is powered by 4 AA type batteries. The Receiver three position slider switch can be set to one of three positions: ON (Manual Override), Remote (Remote control) or Off.

### Initializing the System for the first time

Install 4 AA batteries into the receiver battery bay. Install 3 AAA type batteries in the Transmitter battery bay. Place the 3 position slider switch in the "Remote" position. Insert the end of a paper clip into the hole marked "PRG" on the Receiver front cover. The Receiver will "beep" three (3) times to indicate that it is ready to synchronize with a Transmitter. Push the On button. The Receiver will "beep" four times to indicate the Transmitter's command is accepted. The system is now initialized.

### Temperature indication Display

With the system in the "OFF" position, press the \*thermostat Key and the Mode Key at the same time. Look at the LCD screen on the Transmitter to verify that a C or F is visible to the right of the Room Temperature display.

### Turn the Appliance On or Off

Press the ON/OFF Key on the Transmitter

### Remote Flame Control

The Proflame GTM has six (6) flame levels. Pressing the Down Arrow Key once will reduce the flame height by one step until the flame is turned off. The Up Arrow Key will increase the flame height each time it is pressed. If the Up Arrow Key is pressed while the system is on but the flame is off, the flame will come on in the high position.

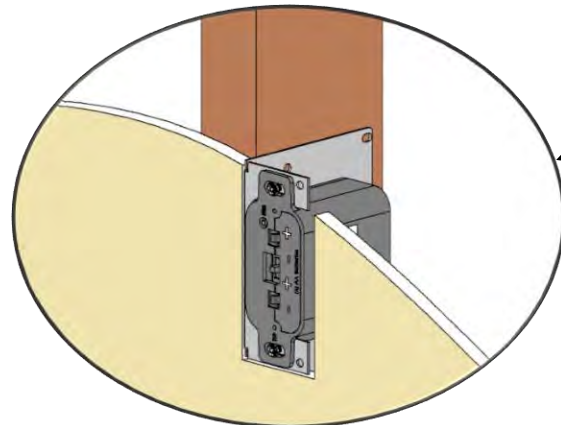

### Wall Mount Option

10ft. Extension Harness (Part No. 1001-P904SI) required.

- The Remote Receiver can be mounted on a vertical wall stud using the DCHS as a mounting bracket.
- Ensure that the face is protruding 1/2" so that the face plate will be flush on the face of the wall.
- Drywall cutout size is 2" wide by 4-1/8" tall.
- Must be installed within 10ft of valve assembly (6ft recommended).

### Room \*thermostat ( Transmitter Operation)

The Remote Control can operate as a room \*thermostat. To activate this function, press the \*thermostat Key. The LCD display on the Transmitter will change to show that the room \*thermostat is "ON" and the set temperature is now displayed. To adjust the set temperature, press the Up or Down Arrow Keys until the desired set temperature is displayed on the LCD screen of the Transmitter.

### Smart \*thermostat (Transmitter Operation)

The Smart \*thermostat function adjusts the flame height in accordance to the difference between the set point temperature and the actual room temperatures. As the room temperature gets closer to the set point the Smart Function will modulate the flame down. To activate this function, press the \*thermostat Key until the word "SMART" appears to the right of the temperature bulb graphic. To adjust the set temperature, press the Up or Down arrow Keys until the desired set point temperature is displayed.

### Key Lock Function

This function will lock the keys to avoid unsupervised operation. To activate this function, press the MODE and the UP Arrow Key at the same time. To de-activate this function, press the MODE and the UP Arrow Key at the same time.

### Low Battery Detection

**Transmitter** - When the Transmitter batteries are low, a Battery Icon will appear on the LCD display of the Transmitter.  
**Receiver** - When the Receiver batteries are low, No "beep" will be emitted from the Receiver when it receives an On/Off command from the Transmitter. When the batteries are replaced the "beep" will be emitted from the Receiver when the ON/OFF Key is pressed (See Initializing the System for the first time).

### Manual Bypass Of The Remote System

If the batteries of the Receiver or Transmitter are low or depleted, the appliance can be turned on manually by sliding the three position slider switch on the Receiver to the ON position. This will bypass the remote control feature and the appliance main burner will come on if the gas valve is in the "On" position.

# IPI Electronic Ignition System

## Overview

The IPI system is an advanced burner controller that provides you with the option of having either a Standing-Pilot, or an intermittent igniting system. This alternating mode is controlled by the CPI/IPI Switch (Continuous Pilot Ignition/Intermittent Pilot Ignition) located on the IPI System Box. The difference between a Standing-Pilot and an Intermittent-Pilot is in whether the pilot stays lit or shuts off:

In Standing-Pilot, the pilot assembly is lit by the IPI Main Module and continues to stay lit until 1) the CPI/IPI Switch is switched to the IPI position; 2) a loss of electrical power (battery and AC source), 3) the flame sensor loses its signal, 4) the fuel supply discontinues, or 5) the IPI Main Module malfunctions.

In the Intermittent-Pilot mode, the pilot shuts off when the appliance is not in use. The advantage of this mode is that fuel is not consumed when the fireplace is not operating.

**NOTE:** In some jurisdictions Intermittent-Pilot is required. That means the pilot cannot remain lit when the appliance is not operating.

## Components

The core of the IPI system is the Main Module and the IPI Valve. With these two components the system is able to operate a gas fireplace. There are also other components available to complement the IPI system.

**IPI System Cover:** Is essential in keeping the components at their proper operating temperatures. **DO NOT OPERATE THE APPLIANCE WITHOUT THIS COVER.**

**Modulating Servo Motor:** Is an add-on valve component that permits HI/LO functionality to be controlled by the remote. Contrary to this feature is a Manual HI/LO Control Knob. The Modulating Servo Motor requires the Remote system to be present.

**Backup Battery Pack:** This component permits the IPI system to operate without the need for an external AC Adapter power source. The advantage to using the battery backup is that in the case of a power failure, the appliance is still operable.

**Remote Receiver:** This component provides the capability of controlling the appliance with a wireless remote transmitter.

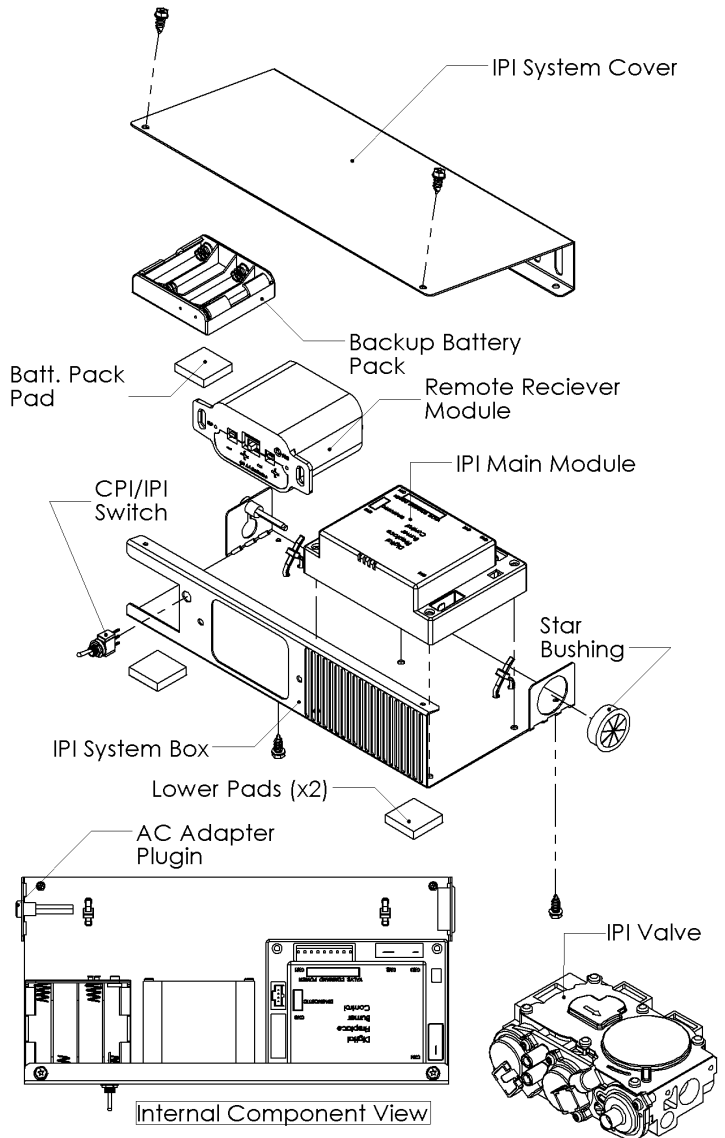

**NOTE:** In certain instances the IPI Main Module requires resetting. This can occur if the system is unable to ignite the pilot or the main burner in the allotted time period. The IPI is programmed to lockout all commands. To reset this lockout you must deplete the system of all electrical power. This means to remove the batteries from the Battery Pack, remove the batteries from the Remote Receiver (if applicable), and disconnect the AC Adapter from the system. Leave the power off for approximately 25 seconds to clear its lockout.

## Standing Pilot Mode for Colder Climates (Below Freezing)

For IPI models it may be necessary to set the appliance to Standing Pilot mode to maintain heat in the cavity. The purpose of this procedure is to prevent cold air from penetrating the chimney and then onto the living space. Therefore, when the internal temperature is slightly elevated the fireplace is able to freely exhaust its combustion and hence making it easier to startup.

**NOTE:** The pilot system for this appliance may be equipped with a Seven Day Timer, in which case the pilot flame will be extinguished if the main burner has not been turned ON for seven days. This Seven Day Cycle is reset every time the main burner is cycled ON / OFF and the pilot remains lit. If more than seven days has passed since the main burner has been cycled ON / OFF and the pilot is also out, follow the procedures described in this manual to light the pilot.

# IPI Electronic Ignition System

**NOTE:** The Remote Receiver module can also be located outside of the appliance to a maximum of 6ft away installed in a certified deep wall switch electrical box (2-3/4" depth). For this configuration an extension wiring harness (P/N: 1001-P904SI) is required.

**Electrical Supply in Series:** The entire IPI system can be powered by a single power source (i.e. by the AC Adapter). This is advantageous if you do not want to supply extra batteries. To achieve this simply connect the AC Adapter into the Remote Control wiring harness instead of the main IPI harness. From the Remote wiring harness, use its male plug-in connector and connect it to the female plug-in in the main IPI harness. Now the circuit is complete. So the way it works is that electrical power is supplied to the Remote Receiver module and then proceeds to the Main IPI module. Furthermore, note that a Backup Battery Pack is not required in this configuration. Instead, batteries in the Remote Receiver act as the backup supply.

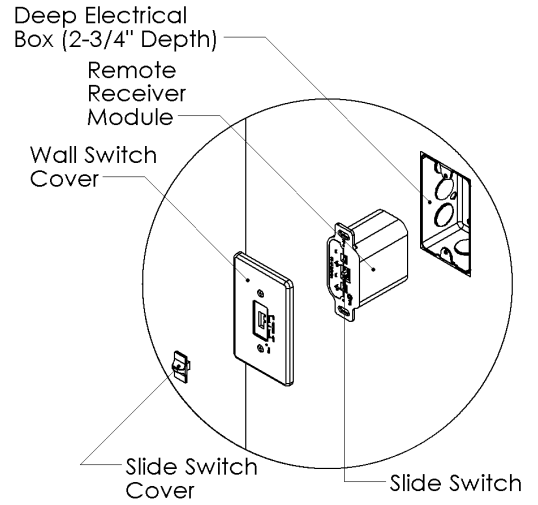

## Junction Box Location

The electrical junction box must be located on the outside of the appliance near the bottom as shown in the illustration to the right. Be sure to follow local electrical codes when install the junction box

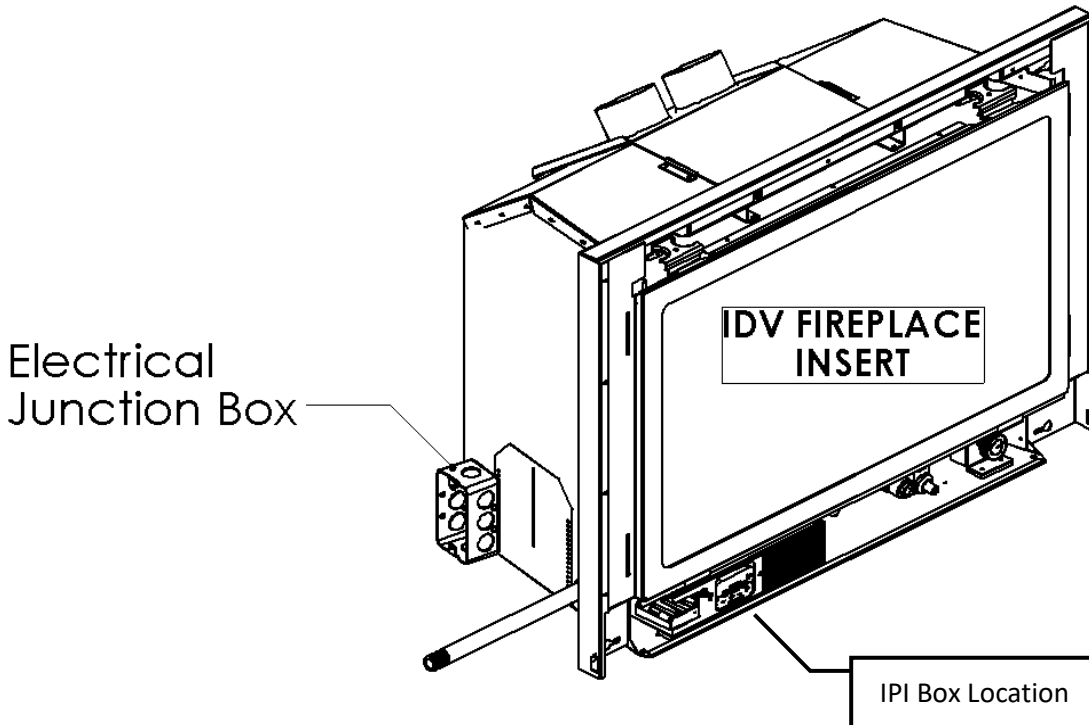

PART NO.	DESCRIPTION
1. 1006-P002SI	Valve IPI Hi/Lo NG
2. 1006-P003SI	Valve IPI Hi/Lo LP
3. 1002-P302SI	IPI Ignition Board
4. 1002-P047SI	Pilot Assembly-LP -24" Wire
5. 1002-P033SI	Pilot Assembly-NG -24" Wire
6. 1002-P850SI	AC Wall Adapter
7. 1002-P12BH	Battery Pack
8. 1001-P280SI	TC - Tubing W/Fittings 1/8 2.182.280
9. 1001-P166SI	TC - Orifice Pilot NG 977.166 #62 (IPI)
10. 1001-P168SI	TC - Orifice Pilot LP 977.168 #35 (IPI)

11. 1002-P012SI	IPI Stepper Kit - LP 907.012
12. 1002-P013SI	IPI Stepper Kit - NG 907.013
13. 1002-P014SI	IPI Reg Kit - LP Hi-Lo 907.014
14. 1002-P016SI	IPI Reg Kit - NG Hi-Lo 907.016
15. 1002-P017SI	TC - Electrode Cable & Sparker IPI 915.017 24"
16. 1002-P119SI	TC - Electrode Cable & Sparker IPI 35" (Infinite, ZCVRB47, VRB46)
17. 1002-P903SI	TC - Electrode Flame Sense IPI 007.253/915.903 24"
18. 1002-P910SI	TC - Electrode Flame Sense 35" (Infinite, ZCVRB47, VRB46)



**Proflame Transmitter**  
1001-P023SI

**NOTE:** Fan and / or Light Options are not available on some fireplaces.  
**Check with your dealer.**

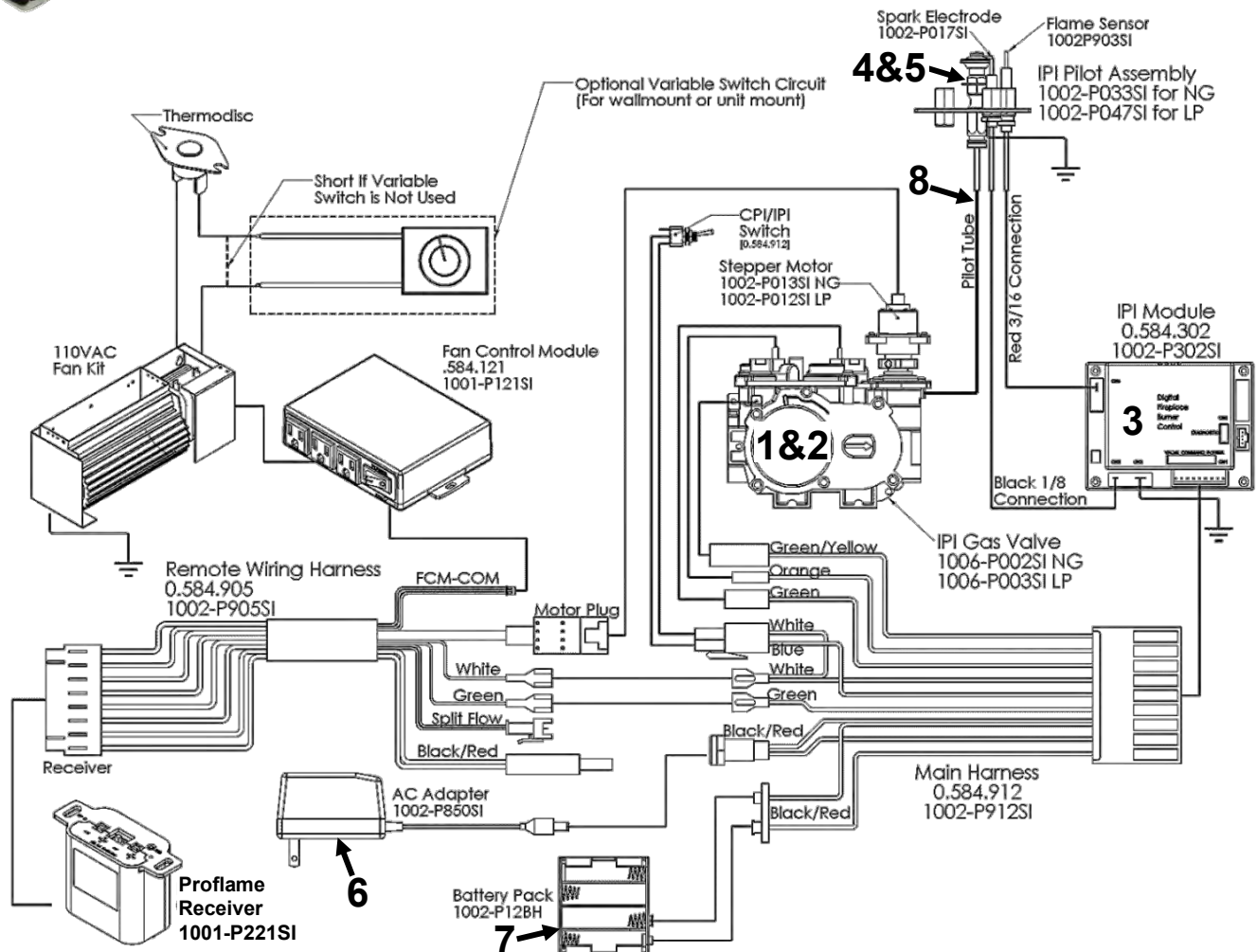



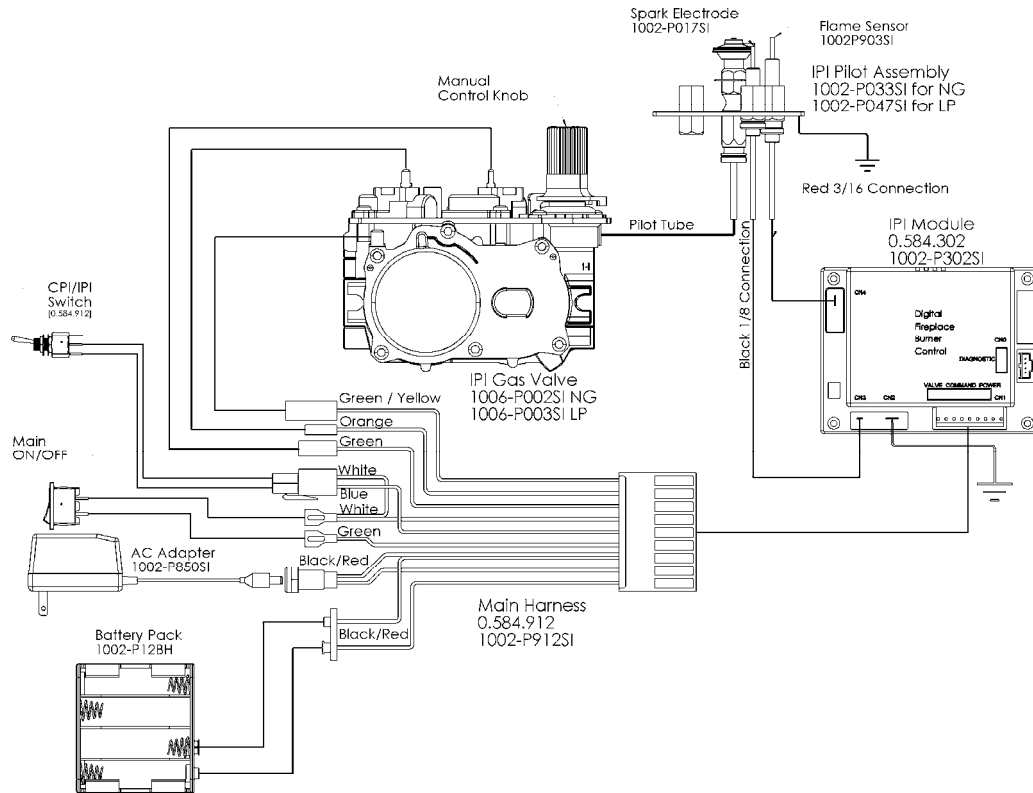

Configuration #1: Basic manual HI/LO and manual ON/OFF capabilities.

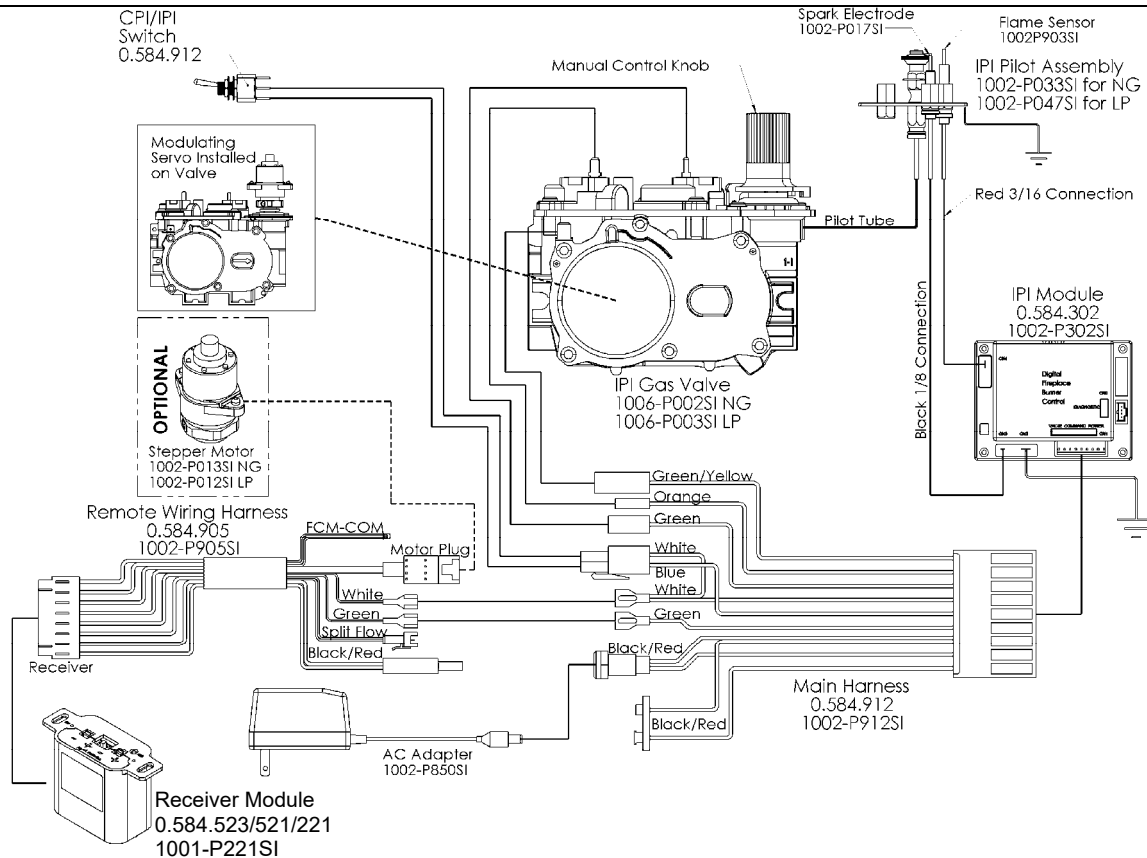

Configuration #2: Remote ON/OFF and manual HI/LO capabilities. OPTIONAL: For units with remote HI/LO capabilities, a modulating servo is required to be installed on the valve. The connectors to this servo must be connected to the Remote Harness as shown in the figure above.

# Operating the Receiver Without Batteries For GT / EGT / GTM / EGTM Remote Controls

-Wiring Harness P/N 1002-P906si required for both IPI & Millivolt systems.

-Millivolt Systems will also require Power Adapter P/N 1002-P850si.

The Remote Receiver & IPI or Millivolt system can be powered by the AC Adapter. This is advantageous if you do not want to use batteries. Simply connect the AC Adapter into the Remote Control Wiring Harness as per the diagrams below.

## IPI System EGTM

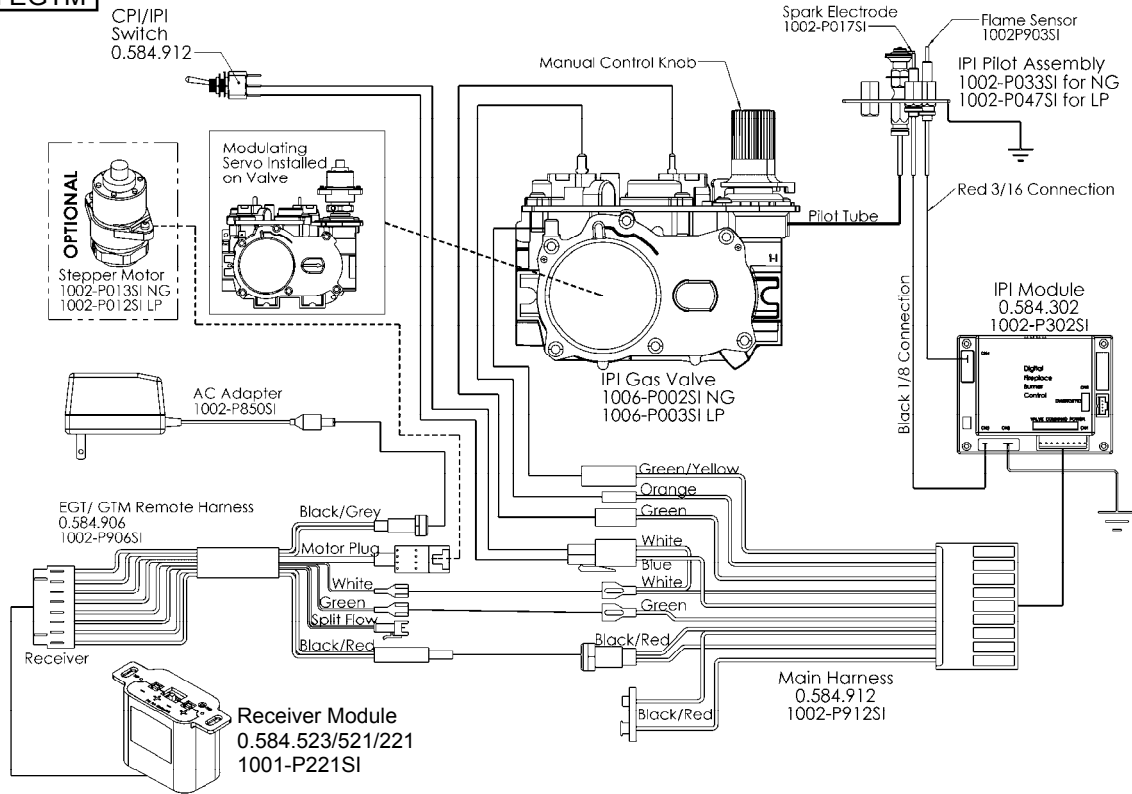

## Millivolt System GTM

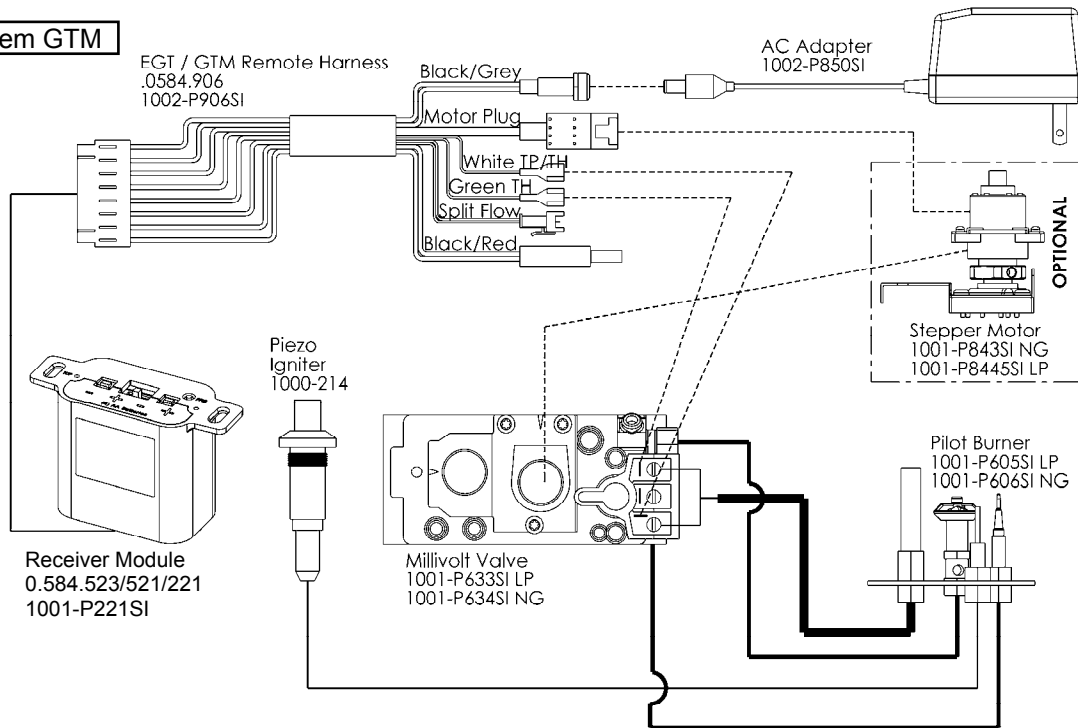

\*In the U.S.A. Thermostats are not permitted for Vented Gas Fireplaces (ANSI Z21.50b-2009 -Decorative).

## - Lighting Instructions - Intermittent Pilot Ignition System (IPI)

### FOR YOUR SAFETY READ BEFORE LIGHTING

**WARNING: If you do not follow these instructions exactly, a fire or explosion may result causing property damage, personal injury or loss of life.**

**Always light the pilot whether for the first time or if the gas supply has run out with the glass door opened or removed.**

#### BEFORE LIGHTING:

- A. This appliance is equipped with an ignition device which automatically lights the pilot. Do not try to light the pilot by hand.
  - B. **BEFORE OPERATING** smell around the appliance area for gas. Be sure to smell next to the floor because some gas is heavier than air and will settle on the floor.
- WHAT TO DO IF YOU SMELL GAS
- Do not try to light any appliance.
  - Do not touch any electric switch; do not use any phone in your building.
  - Immediately call your gas supplier from a neighbor's phone. Follow the gas supplier's instructions.
- C. Do not use this appliance if any part has been under water. Immediately call a qualified service technician to inspect the appliance and replace any part of the control system and any gas control which has been under water.
  - D. If the gas valve requires repair, call a qualified service technician. Force or attempted repair may result in a fire or explosion.

### OPERATING INSTRUCTIONS

1. Stop! Read the safety information above on this label.
2. Remove batteries from receiver, and/or Battery Backup Pack.
3. Turn off all electric power to the appliance.
4. This appliance is equipped with an ignition device which automatically lights the pilot. Do not try to light the pilot by hand.
5. Open the glass door.
6. Turn manual shutoff valve clockwise ↻ to off (Located behind the access panel).
7. Wait five (5) minutes to clear out any gas. Then smell for gas, including near the floor. If you smell gas, STOP! Follow "B" in the safety information above this label. If you do not smell gas, go to next step.
8. Turn manual shutoff valve counter-clockwise ↻ to on.
9. Close the glass door.
10. Turn on all electric power to the fireplace and re-install batteries into the Transmitter/Receiver, and/or Battery Backup Pack.
11. Turn "On" Switch that operates the Main Burner. If using a Remote Control refer to Remote Control Operation Manual for activation.
12. If the appliance will not operate, follow the instructions "To Turn Off Gas To Appliance" and call your service technician or gas supplier.

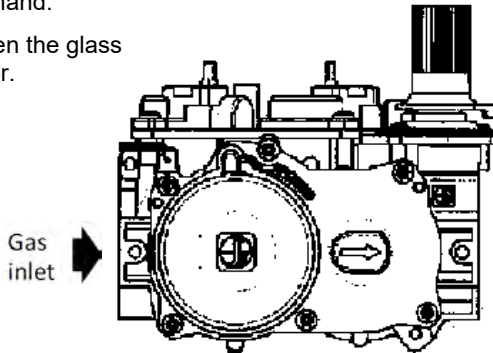

### TO TURN OFF GAS TO APPLIANCE

1. Turn off all electric power to the fireplace if service is to be performed, including removing batteries from Remote Transmitter/Receiver and/or Battery Backup Pack.
2. Remove control access panel.
3. Turn manual shutoff valve clockwise ↻ to off (Located behind the access panel).  
If alternate shut-off valve was installed it can be shut off instead of going through the fireplace to access the fireplace shutoff valve.
4. Replace control access panel.

**IPI PROFLAME 2 - COMPONENT PARTS**

PART NO.	DESCRIPTION
1. 1005-P001SI	Valve IPI Proflame PF2 885.001 NG - Stepper
2. 1005-P002SI	Valve IPI Proflame PF2 885.002 LP - Stepper
3. 1005-P325SI	Module IPI - Proflame 2 - 584.325
4. 1005-P924SI	Harness PF2 - 584.924
5. 1005-P042SI	Transmitter - PF2 - Black 584.042
6. 584-PWR-C	Wire Harness PF2 – Power Cord
7. 584-X4P	Terminal Block
8. 584-X10	Wire Harness PF2
9. 584-ACC01-C	Wire Harness PF2 - Fan/Light
10. 584-X8-B	Wire Harness PF2 - Optional Reset Harness
11. 584-X12	Optional Power Vent Harness

**NOTE:** Fan and / or Light Options are not available on some fireplaces.  
**Check with your dealer.**

**IPI - PF1 and PF2 Common Components**

PART NO.	DESCRIPTION	
12. 1002-P033SI	TC - Pilot Burner IPI (Assembled) NG 199.033	
13. 1002-P047SI	TC - Pilot Burner IPI (Assembled) LP 199.047	
14. 1001-P166SI	TC - Orifice Pilot NG 977.166 #62 (IPI)	
15. 1001-P168SI	TC - Orifice Pilot LP 977.168 #35 (IPI)	
16. 1001-P280SI	TC - Tubing W/Fittings 1/8 2.182.280	
17. 1002-P012SI	IPI Stepper Kit - LP 907.012	<b>P2 CONVERSION</b>
18. 1002-P013SI	IPI Stepper Kit - NG 907.013	
19. 1002-P014SI	IPI Reg Kit - LP Hi-Lo 907.014	<b>P1 CONVERSION</b>
20. 1002-P016SI	IPI Reg Kit - NG Hi-Lo 907.016	
21. 1002-P017SI	TC - Electrode Cable & Sparker IPI 915.017 24"	
22. 1002-P119SI	TC - Electrode Cable & Sparker IPI 35" (Infinite, ZCVRB47, VRB46)	
23. 1002-P12BH	IPI Battery Housing 12bh347-Gr	
24. 1002-P903SI	TC - Electrode Flame Sense IPI 007.253/915.903 24"	
25. 1002-P910SI	TC - Electrode Flame Sense 35" (Infinite, ZCVRB47, VRB46)	

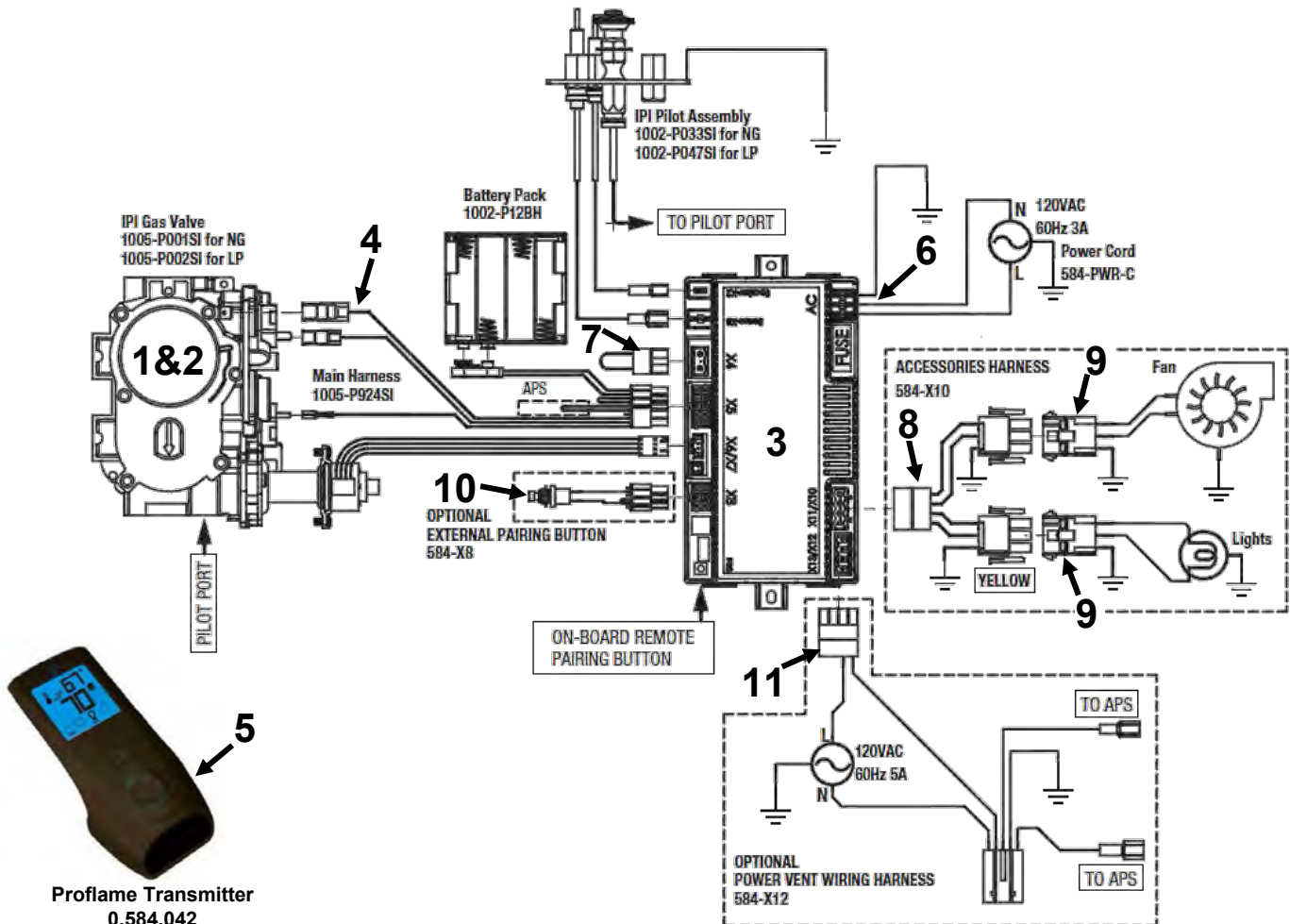



# Proflame 2 IFC Module and Remote Control

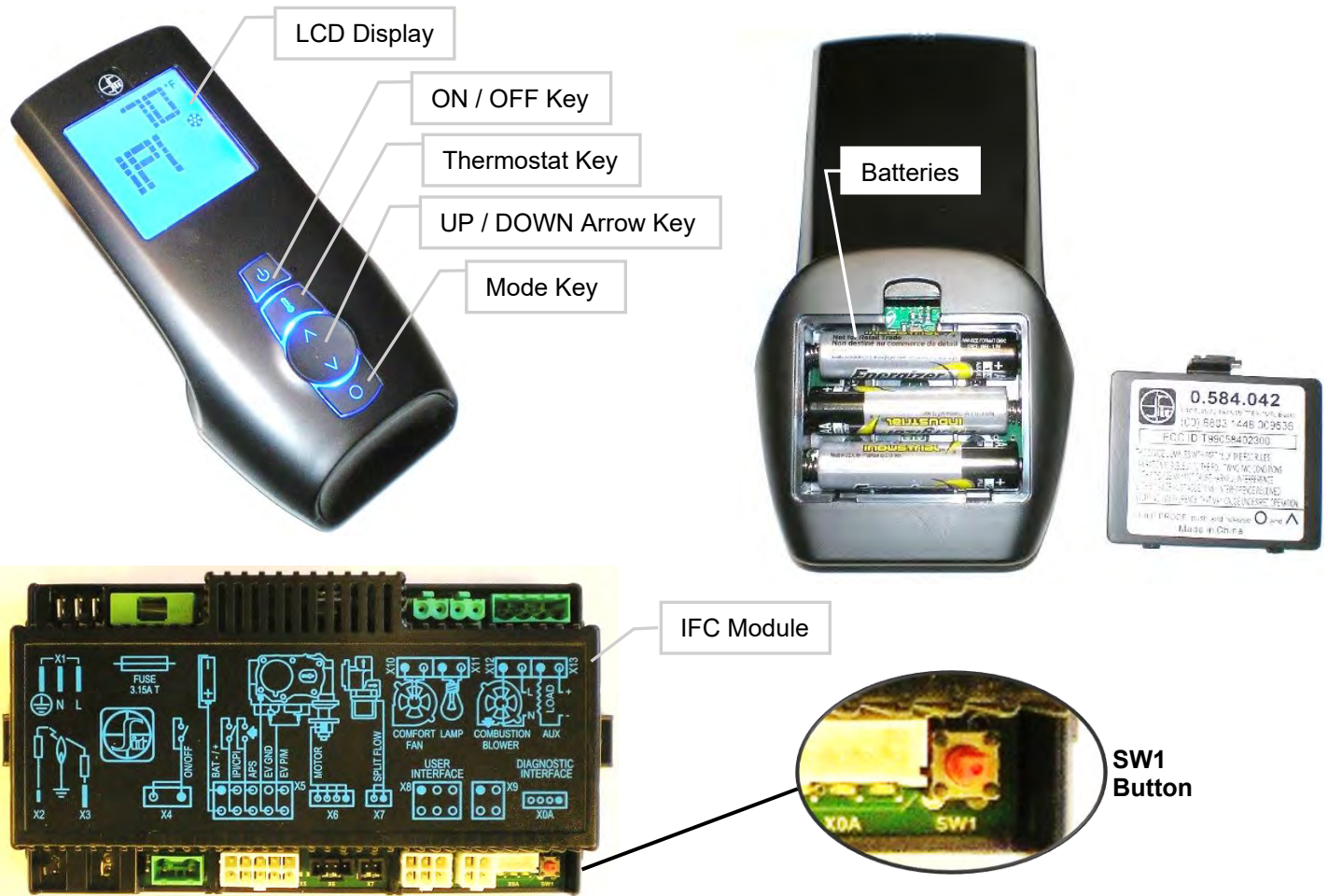

## Pairing Remote Control:

- Install the 3 AAA type batteries in the battery bay, located on the base of the Remote Control. Note polarity of the batteries and insert them as indicated.
- Connect the AC power supply to the IFC Module.
- Press the SW1 button on the IFC Module so the IFC will “beep” and a red LED is illuminated to indicate that the IFC Module is ready to synchronize with a Remote Control within 10 seconds. With the batteries already installed in the Remote Control, push the ON button. The receiver will “beep” four times to indicate the Remote Control’s command is accepted.

The system is now initialized.

## Resetting Proflame 2 IFC Module for Manual Use

If the transmitter gets misplaced, is broken, or is no longer wanted the PF2 Module can be reset to a manual system. A manual on/off switch or thermostat may be installed at the X4 connector (this connection is Jumped at the factory) no power is required.

The following sequence must be followed to reset the PF2 Module:

- Press the Red **SW1** button until you hear three beeps.

- Within 10 seconds press the **SW1** button again until you hear it beep.
- The PF2 Module may now be turned on/off manually (x4 connector) by a switch (not supplied), the pilot will remain on CPI (continuous pilot ignition) mode, all other functions of main burner, fan and lights will be on the high setting.

## Fan Startup and Shutdown Timings:

Fan setting is started with a delay of 5 minutes from the fireplace ignition and stopped with a delay of 12 minutes from the fireplace switching off.

## Low Battery Power Detection

When the Remote Control’s batteries are low, a Battery Icon will appear on the LCD display before all power is lost. When the batteries are replaced this icon will disappear.

## Battery Backup

The PF2 module is powered by line voltage (AC) with provision of battery backup in case of main power loss. Fans and lighting features will not function with the PF2 Module is powered by battery backup. It is recommended that the 4 x AA batteries are changed before each heating season.

## Cold Climates – CPI Setting - Proflame 2 Remote Control

Use the **CPI setting** during cold weather, otherwise the fireplace may have a hard time starting up and establishing a flame. The **CPI** (Continuous Pilot Ignition) setting will keep the firebox and fireplace exhaust vent warm during cold weather. When the firebox and exhaust vent are warm, exhaust gasses will readily flow out of the firebox.

If the firebox and venting are too cold, there is resistance due to the heavy cushion of cold air, and combustion gasses may not rise into the exhaust vent, thus causing the fireplace to cycle or **Lockout** (if this happens see **Lockout Reset Procedures** below).

**NOTE:** The pilot system for this appliance may be equipped with a **Seven Day Timer**, in which case the pilot flame will be extinguished if the main burner has not been turned ON for seven days. This Seven Day Cycle is reset every time the main burner is cycled ON / OFF and the pilot remains lit. If more than seven days has passed since the main burner has been cycled ON / OFF and the pilot is also out, follow the procedures described in this manual to light the pilot.



### To switch from IPI to CPI Mode:

1. Turn the fireplace OFF using the **ON / OFF Key**.

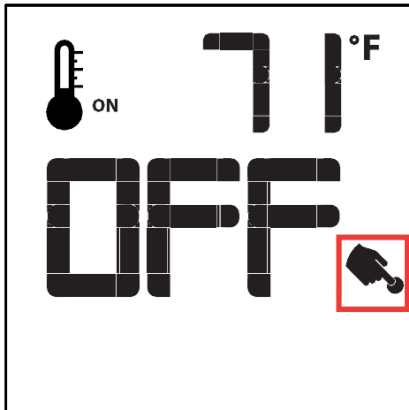

2. Press the **Mode Key**. Display will appear as below.

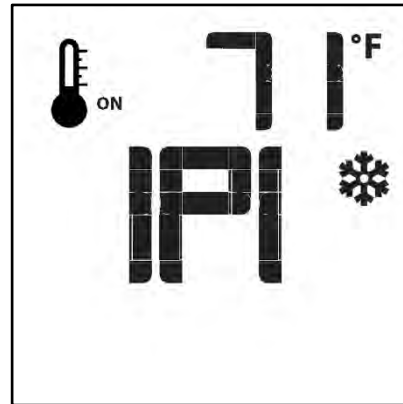

3. Press UP on the **UP / DOWN Arrow Key**. Display will show **CPI**.

The module in the fireplace will beep once to confirm command.

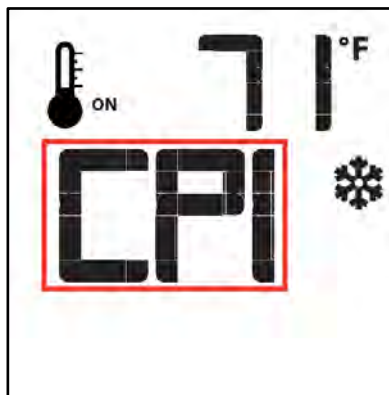

### TO RETURN TO IPI (INTERMITTENT PILOT) MODE:

Repeat steps one and two, and then press DOWN on the **UP / DOWN Arrow Key**.

The module in the fireplace will beep once to confirm command.

## Lockout Reset Procedures – Proflame 2

If the fireplace has cycled too many times in a short period of time, it will shut down and become unresponsive to any new command.

The LED light on the Proflame 2 module in the fireplace will be flashing red.

This condition is a **Lockout** state.

### Lockout Reset Procedure:

1. Disconnect power from the Proflame 2 module in the fireplace for 10 seconds. This includes removing the backup batteries.
2. Once the 10 second interval has passed, reconnect power and reinstall backup batteries. The pilot should now try to light.
3. If the fireplace does not come on, call your fireplace technician.

## Proflame 2 Remote Control

### Remote-Flame Control

The proflame has six (6) flame levels. With the system on, and the flame level at the maximum in the appliance, pressing the Down Arrow Key once will reduce the flame height by one step until the flame is turned off.

The Up Arrow Key will increase the flame height each time it is pressed. If the Up Arrow Key is pressed while the system is on but the flame is off, the flame will come on in the high position. ( Fig. 7 & 8 ) A single "beep" will confirm reception of the command.



Fig. 7: Flame Off

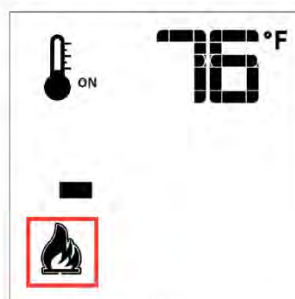

Flame Level 1

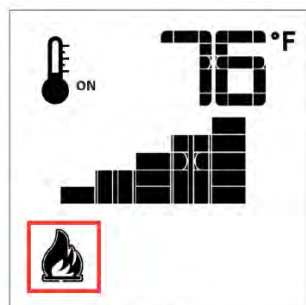

Fig. 8: Flame level 5



Flame Level Maximum

### Room Thermostat ( Transmitter Operation)

The Remote Control can operate as a room thermostat. The thermostat can be set to a desired temperature to control the comfort level in a room.

To activate this function, press the Thermostat Key (Fig. 1). The LCD display on the Transmitter will change to show that the room thermostat is "ON" and the set temperature is now displayed (Fig. 9). To adjust the set temperature, press the Up or Down Arrow Keys until the desired set temperature is displayed on the LCD screen of the Transmitter.

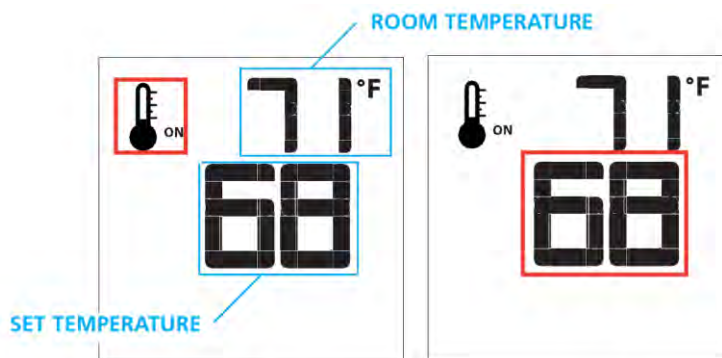

Fig. 9

Fig. 10



## Smart Thermostat (Transmitter Operation)

The Smart Thermostat function adjusts the flame height in accordance to the difference between the set point temperature and the actual room temperatures. As the room temperature gets closer to the set point the Smart Function will modulate the flame down. To activate this function, press the Thermostat Key (Fig. 1) until the word "SMART" appears to the right of the temperature bulb graphic (Fig. 11).

To adjust the set temperature, press the Up or Down Arrow Keys until the desired set temperature is displayed on the LCD screen of the Transmitter (Fig. 12).

**Note:**  
When Smart Thermostat is activated, manual flame height adjustment is disabled.

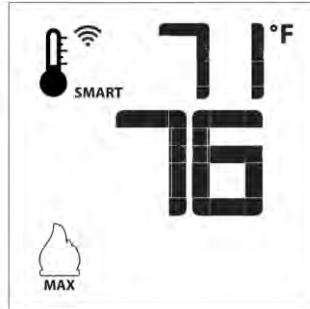

Fig. 11: Smart flame function



Fig. 12

## Fan Speed Control

If the appliance is equipped with a hot air circulating fan, the speed of the fan can be controlled by the Proflame system. The fan speed can be adjusted through six (6) speeds. To activate this function use the Mode Key (fig.1) to index to the fan control icon (Fig. 13). Use the Up/Down Arrow Keys (Fig.1) to turn on, off or adjust the fan speed (fig. 14). A single "beep" will confirm reception of the command.



Fig. 13

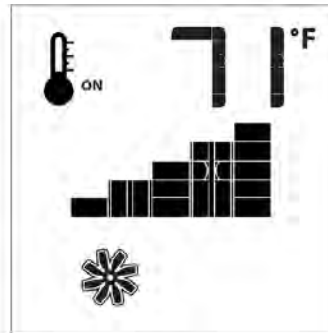

Fig. 14

## Remote dimmer control (Light)

The auxiliary function controls the AUX power outlet by the dimmable light control. To activate this function use the Mode Key (fig. 1) to index to the AUX icon (fig. 15 & 16).

The intensity of the output can be adjusted through six (6) levels. Use the Up/Down Arrow Keys (Fig.1) adjust the output level (fig. 16). A single "beep" will confirm reception of the command.

**Note:**  
This function is only available in Room Thermostat or Smart Thermostat Control Mode.



Fig. 15

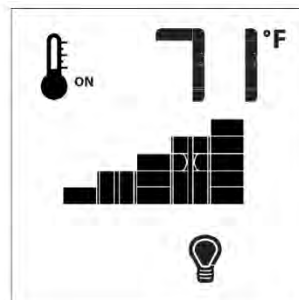
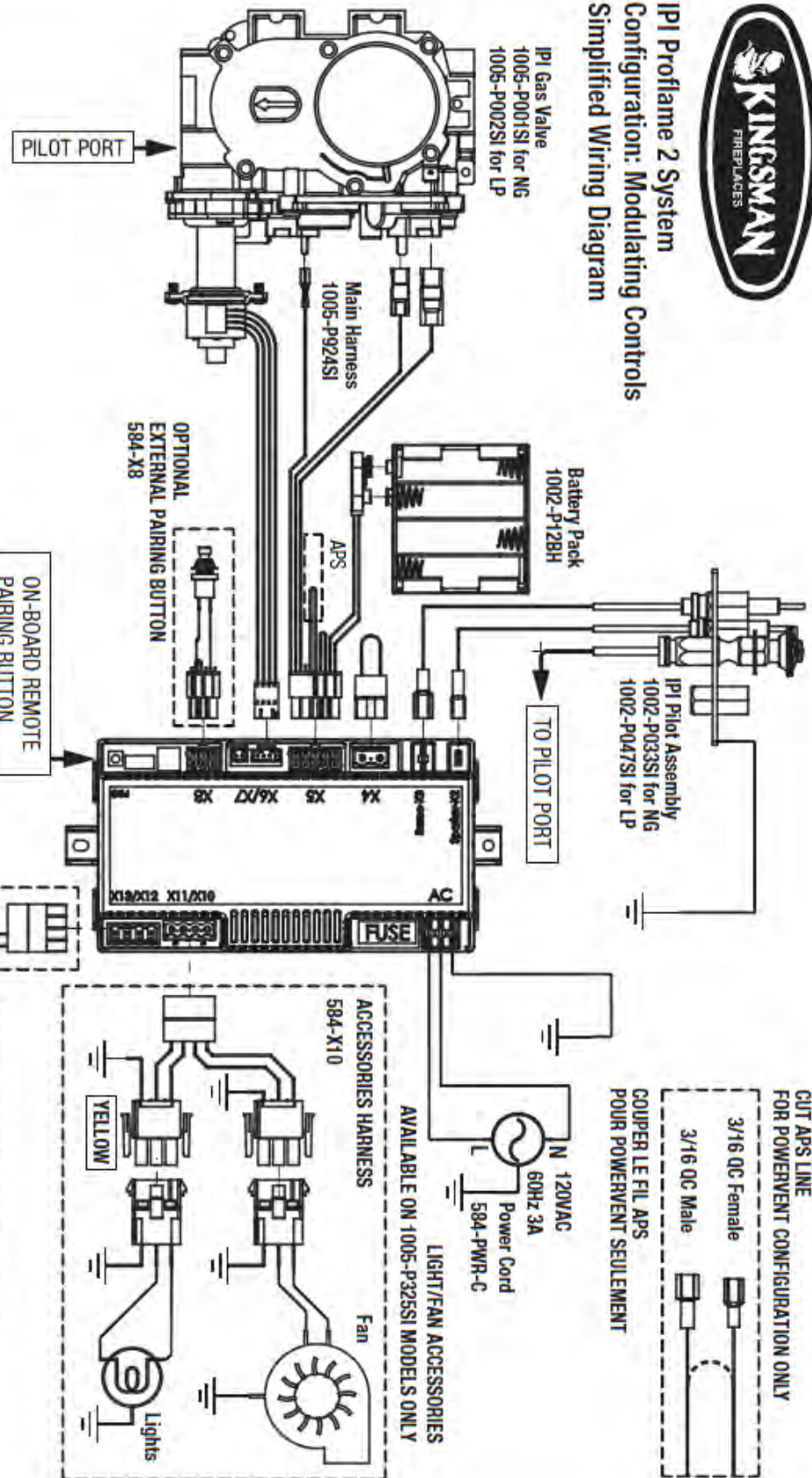

Fig. 16





# IPI Proflame 2 System Configuration: Modulating Controls Simplified Wiring Diagram



Manufactured by: Kingsman Fireplaces  
2340 Logan Avenue  
Winnipeg, MB R2R 2V3

For use with all Kingsman manufactured IPI Proflame 2 models, for all types of gas noted on rating plate. Supply 120VAC 60Hz 3A, 6 volts battery backup.

Pour utilisation avec tous les modèles IPI Proflame 2 fabriqués par Kingsman, pour tous les types de gaz noté sur la plaque signalétique. Voltage d'alimentation: 120VAC 60Hz 3A et 6 volts pour le bloc-piles de secours.

This component should be installed by a qualified service agency.  
Cette composante doit être installée par une entreprise de service qualifiée.

Part #1005-P2SC4H

**PARTS LIST:**

- [1] – Co-linear termination
- [8] - #8 washers
- [8] - #8 x 1 PH Quad
- [8] - #8-18 x 3/4" PH DT
- [1] – Tube Millpac Black

**Vertical Venting in Cold Climates**

In cold climate conditions where temperatures go below -10°C [14°F], we recommend that the chase be insulated and where the vent pipe enters into the attic space that the pipe be wrapped with an insulated Mylar sleeve. This will increase the temperature of the vent and help the appliance to vent properly in cold weather conditions.

It is also important in vertical vented direct vent appliances that the appliance be operated daily during the winter months as this will help stop the Termination from freezing up. We recommend using a thermostat set at room temperature to allow the unit to cycle.

For IPI models it may be necessary to set the appliance to Standing Pilot mode to maintain heat in the cavity. The purpose of this procedure is to prevent cold air from penetrating the chimney and then onto the living space. Therefore, when the internal temperature is slightly elevated the fireplace is able to freely exhaust its combustion and hence making it easier to startup.

This appliance must not be connected to a chimney flue serving a separate solid-fuel burning appliance.

This appliance is approved with Kingsman Flex Vent System (as listed in the manual) or MG Duravent flex pipe system.

All venting lining products must be approved and installed according to the vent manufacturers installation instructions. All vent liners must terminate in a rain cap to prevent debris and rain from entering the vent and possibly damaging the appliance or creating an unsafe condition. The area between the existing chimney and liner must be capped off for the same reasons as above and to reduce the chances of venting problems and corrosion of the vent.

If this fireplace insert is to be used to replace an existing fireplace insert the existing vent liner must be of the proper size and if so must be inspected for obstructions, damage and/or corrosion. Replacement must be done as necessary.

Before any vent liner is run through a chimney or other approved venting system, chimney must be inspected, cleaned and repaired if necessary. A chimney which was used for a solid fuel fireplace must be professionally cleaned in order to reduce corrosion of the vent or other possible safety hazards.

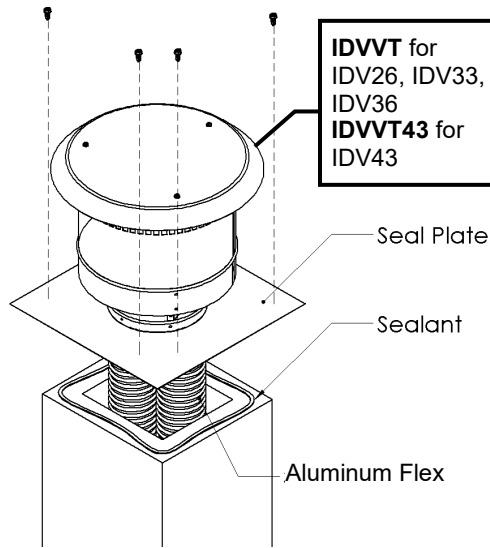

**IDVVT for IDV26, IDV33, IDV36  
IDVVT43 for IDV43**

**Installation of Vertical Termination**

1. Before attaching the flex vents to the termination, you will have to determine how the cap will be attached to the existing chimney crown, clay lined chimney or wood stove vent pipe. The Seal Plate of the termination may be cut, notched and formed to make a good seal to the existing vent or be left flat.
2. Using a high quality sealing compound (RTV Silicone) place a bead of sealant onto the vent or chimney top. This will provide a seal against water and rain from entering the existing flue.
3. Attach the vent pipes to the termination with Millpac and [4] screws and washers per pipe joint. Be sure to label the exhaust and intake flex pipes. Make sure not to connect the exhaust to the intake or vice versa. Lower the termination and vent pipe down the vent and screw the seal plate to the chimney crown, clay tile chimney, or wood stove vent. It may be necessary to predrill holes into the chimney crown (depending on material) [8 screws].

	Vertical (rise)	Horizontal (run)
Min.	12ft [3.7m]	0ft [0m]
Max.	40ft [12.2m]	2ft [0.6m]

Venting System for IDV26, IDV33, IDV36	
<b>IDVVT</b>	Vertical Vent Termination
<b>IDVFK25</b>	Flex Pipe kit ([Qty 2] 3" x 25ft unexpanded flex pipes complete with Millpac and screws.)
<b>#46DVA-CL33</b>	MG Duravent Kit (Termination cap and [2] pieces of aluminum flex 35' long)

Venting System for IDV43	
<b>IDVVT43</b>	Vertical Vent Termination
<b>I43FK25</b>	Flex Pipe kit ([Qty 1] 3" x 25ft Intake, [Qty 1] 4" x 25ft exhaust) Unexpanded flex pipes complete with Millpac and screws.
<b>46DVA-CL34</b>	MG Duravent Kit (Termination cap and [2] pieces of aluminum flex 35' long)

**⚠ WARNING:** Failure to position the parts in accordance with these diagrams or failure to use only parts specifically approved with this appliance may result in property damage or personal injury.

**Cutting any sheet-metal parts of the fireplace, in which the gas fireplace insert is to be installed, is prohibited.**

## IDV26 / IDV33 / IDV43 Installation of Vent Pipe

1. Remove the Top Filler and adapter plate from the unit by removing the five [5] screws as shown below. (Fig. 3) Attach the vent pipes to the termination with Millpac and 4 screws per pipe joint. Be sure to label the exhaust and intake flex pipes. Make sure not to connect the exhaust to the intake or vice-versa. Lower the termination and vent pipe down the vent and screw and seal plate to the chimney crown, clay tile chimney or wood stove vent. It may be necessary to pre-drill holes into the chimney crown (depending on material) (8 screws).
2. The two vent pipes should now be hanging in the existing fireplace. Attach the adapter to the two suspended vent pipes with Millpac and screws. Let the adapter hang in place until the unit is ready to be positioned.
3. Slide the unit into place carefully. Ensure that the adapter slides along the top of the unit, in between the guides, and check that it remains flat. (Fig. 2)
4. Once the unit is slid back into position use the two screws previously removed to secure the adapter plate. When tightening the adapter plate check to make sure the plate is flat to the unit and the rear catch lock is engaged over the rear tab of unit. (Fig. 2 & 3)
5. For I33CV/I43CV models only: Reattach the Top Filler (Fig. 1A) with three [3] screws before installing the I33CV/I43CV Fronts.
6. When using the I33LK/I43LK unit discard the Top Filler Panel and attach the I33LK/I43LK Front as per the instructions shown in the Front Face Attachment Installation section.
7. Use Millpac to seal the vent pipe joints and ensure that it is free of any leakage.

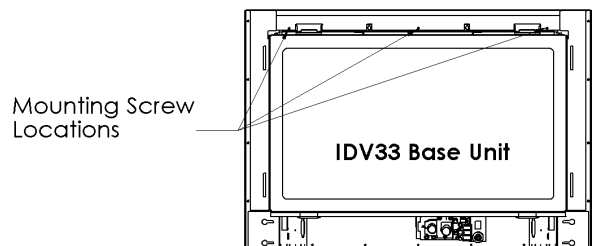
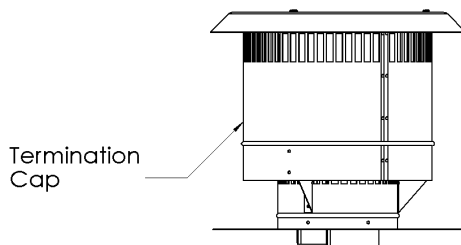

Fig. 1A - Base unit.

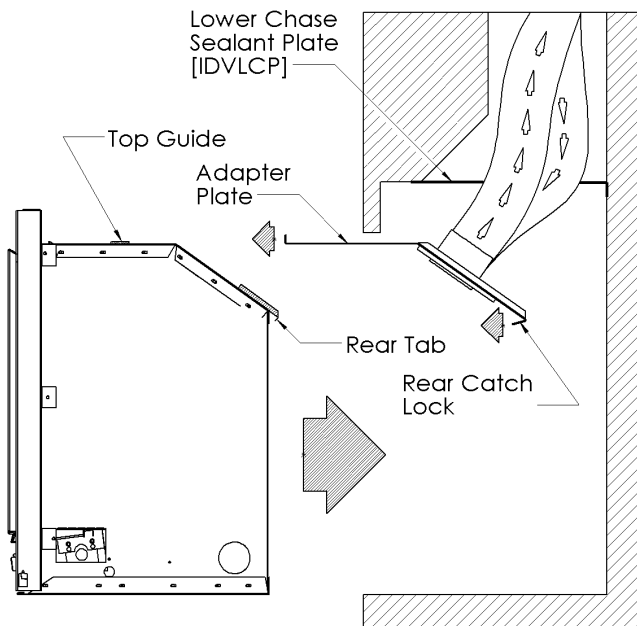

Fig. 2 - Base unit chimney venting install.

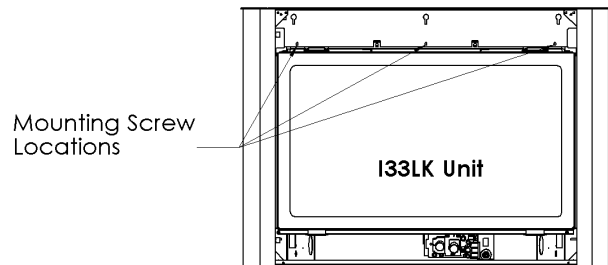

Fig. 1B - Louver kit unit.

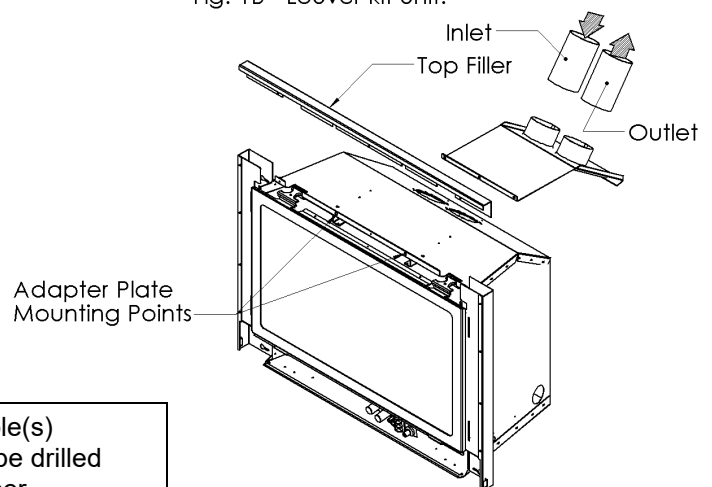

Fig. 3 - Remove top filler to install venting adapter.

**NOTE:** If the factory-built fireplace has no gas access hole(s) provided, an access hole of 1.5in [37.5mm] or less may be drilled through the lower sides or bottom of the firebox in a proper workmanship like manner. This access hole must be plugged with non-combustible insulation after the gas supply line has been installed.

## If You Live in A Cold Climate Zone and Your Chimney Is On The Side Of Your House

In cold climates, especially where the chimney is located on the outside of the home it may be necessary to insulate the chimney cavity with NON-COMBUSTIBLE insulation such as Thermafiber or Roxul insulation. This will keep the chimney cavity warm and avoid cold start ignition problems.

**FOLLOW ALL LOCAL CODES.**

NON-COMBUSTIBLE INSULATION  
(Thermafiber, Roxul, etc.)

IDVLCP  
(Seal this plate with RTV Red Silicone.)

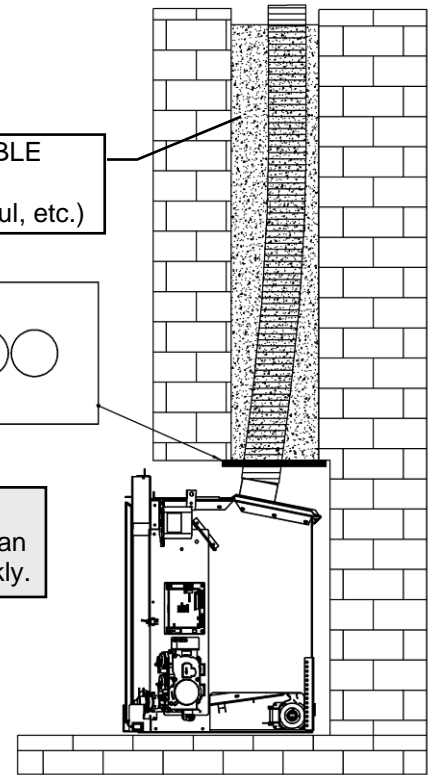
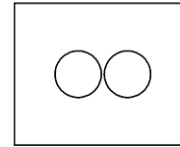

### -Vertical Venting Runs Taller Than 15 Feet-

We recommend that the pilot be left on at all times for vertical venting runs taller than 15 feet. This will maintain a slight draft in the vent, allowing the burner to light quickly.

The pilot should be lit ½ hour before turning on appliance.  
The pilot should be left on during the heating season.

## PROFLAME 1 IPI (Intermittent Pilot Ignition) Appliances Cold Climate Mode

For (IPI) Intermittent Pilot ignition appliances in colder climates (below freezing) it will be necessary to have the continuous pilot (cold climate mode) operation turned on where a heated chimney is needed to maintain the draft to ensure proper operation.

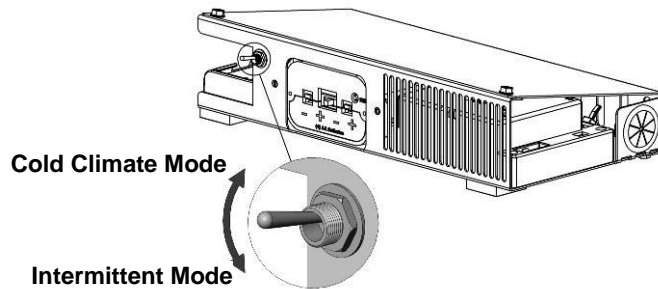

This appliance may run with the pilot continuously running (cold climate mode) or in intermittent mode. For most homeowners, the intermittent mode is preferred (as this saves fuel). However, in some situations the homeowner may prefer to switch the appliance to cold climate mode. The most typical reasons for switching to cold climate mode are:

- Cold Conditions (below freezing) – you may notice that the burner does not light quickly, and the flames lift off the burner. If this is the situation, we recommend you switch to continuous pilot/cold climate mode. This will keep the cavity warm and will create a slight draft in the vent, allowing for the burner to light quickly and draft correctly.
- Condensation on Glass after Startup – certain installations may encounter excessive fogging on the window after startup (not just the first time the appliance was started). This is normal but may be remedied or reduced by switching the appliance to cold climate mode.
- Cold Glass or Hearth area – in cold conditions you may notice that the floor, hearth area and glass become cold. To remedy this, switch the appliance to cold climate mode.
- Frequent On/Off Operation – if you are frequently turning the appliance on and off, you may wish to leave it in cold climate mode. This allows the burner to turn on more quickly, without the pilot ignition sequence.



## IDV26 Parts List

### Part No. Description

#### Fireplace Base Unit

IDV26N [Millivolt]	INSERT DIRECT VENT FIREPLACE
IDV26NE [IPI]	Natural Gas 30,000 BTU
IDV26NE2 [IPI]	INSERT DIRECT VENT FIREPLACE Natural Gas 30,000 BTU, c/w Remote Control
IDV26LP [Millivolt]	INSERT DIRECT VENT FIREPLACE
IDV26LPE [IPI]	Liquid Propane 30,000 BTU
IDV26LPE2 [IPI]	INSERT DIRECT VENT FIREPLACE Liquid Propane 30,000 BTU, c/w Remote Control

#### Fireplace Requirements (Required for Each Unit)

#### Log Sets & Glass Support Platforms

MQLOGF26	7 Piece Log Set
LOGF27	3 Piece Log Set
RSP10	Glass Support Platform with bronze glass
36IDV-204	Pilot Shield for RSP10

#### Marquis Cappella Options

MQRSP4	Rock Support Platform (IDV26 / IDV33 / IDV43)
MQROCK2	Rock Set - Contemporary Collection - Natural
MQROCK3	Rock Set - Contemporary Collection - Multi- Colored
MQRSP8	Glass Support Platform (IDV26 / IDV33 / IDV43)
36IDV-205	Pilot Shield for MQRSP8
MQG5W	Decorative Glass - 1/2" White - 5lbs
MQG5A	Decorative Ember Glass - 1/2" Azuria (Light Blue) - 5 lbs
MQG5C	Decorative Ember Glass - 1/2" Bronze - 5 lbs
MQEMBER3	Ember Chunks - (3 bags)
MQSTONE	Decorative Stones

#### Front Face Attachments

I26CV1BL	Clean View Front [Black]
I26CV3BL	Clean View Front [Black]
I26CVPF1BL	Clean View Front - Picture Frame [Black]
I26CV2BL	Clean View Front -Wide [Black]
I26CVPF2BL	Clean View Front - Picture Frame -Wide [Black]

#### I26CV Surround Kits for Clean View

I26S1BL	Straight Surround Back Extension [Black]
I26SPF1BL	Picture Frame Surround Extension [Black]
I26SU	Universal (for custom applications)
IDV26CSS	Safety Screen Replacement

#### Brick and Porcelain Liners

IDV26RL	Brick Liner
IDV26PRL	Porcelain Liner

#### IDV26 Conversion Kits

26IDV-CKNG	Conversion Kit Natural Gas (IDV26N) [Millivolt]
26IDV-CKLP	Conversion Kit - Liquid Propane (IDV26LP) [Millivolt]

26IDV-CKNGI	Conversion Kit Natural Gas (IDV26NE) [IPI]
-------------	---

26IDV-CKLPI	Conversion Kit - Liquid Propane (IDV26LPE) [IPI]
-------------	---

26IDV-CKNG2	Conversion Kit Natural Gas Proflame 2
-------------	---------------------------------------

26IDV-CKLP2	Conversion Kit Propane Proflame 2
-------------	-----------------------------------

#### Fan

26IDV-P260	Blower Motor (Replacement) QLK45
------------	----------------------------------

#### Riser Kits

I33R40	2-1/2" Riser for use with I33S4028B and I36S3931B
--------	--

I33R44	2-1/2" Riser for use with I33S4430B and I36S4432B
--------	--

#### Mantel Clearance Shield

I33CS	Mantel Clearance Shield <b>For IDV26 / IDV33 / IDV43</b> (Must be used with a CV and I26S1 or I26SPF1 / I33SS1 / I36SS1 Surrounds)
-------	---

#### Other Accessories

Z2MT	Thermostat Digital - Vertical Wall Mount - MV/PF1
------	--

Z80PT	Thermostat Programmable Digital Millivolt Wall Mount (1F80-40)
-------	---

DCHS	Remote Control Heat Shield
------	----------------------------

GTRC	Remote Control Millivolt (Thermostat)
------	---------------------------------------

GTMRCN	Remote Control Millivolt (Thermostat/Modulating – NG)
--------	--

GTMRCP	Remote Control Millivolt (Thermostat/Modulating – LP)
--------	--

1001-P904SI	Remote Receiver Extension Harness (GT Series Remotes Only)-10ft.
-------------	---

EGTRC	Remote Control IPI (Thermostat)
-------	---------------------------------

EGTMRCN	Remote Control IPI (Thermostat/Modulating – NG)
---------	--

EGTMRCP	Remote Control IPI (Thermostat/Modulating – LP)
---------	--

#### Millivolt Replacement Burner Assembly / Burner

33IDV-BNGSI	Millivolt Burner Assembly [NG] c/w Valve System (For use on IDV33N only)
-------------	--

33IDV-BLPSI	Millivolt Burner Assembly [LP] c/w Valve System (For use on IDV33LP and IDV43LP)
-------------	--

36IDV-BNGSI	Millivolt Burner Assembly [NG] – c/w Valve System (For use on IDV43N only)
-------------	--

33IDV-200A	H-Burner (For use on IDV33/IDV43 only)
------------	---

#### Valve System Parts - New Top convertible SIT (Millivolt)

1000P-136WR	Thermopile GOAI-524
-------------	---------------------

1001-P069SI	Electrode Sparker & wire 915.069 TC SIT
-------------	--

1001-P216SI	Thermocouple 290.216 TC SIT
-------------	-----------------------------

1001-P165SI	Orifice Pilot NG 977.165 TC SIT
-------------	---------------------------------

1001-P167SI	Orifice Pilot LP 977.167 TC SIT
-------------	---------------------------------

1001-P633SI	Valve Nova LP Hi/Lo 0820633
-------------	-----------------------------

1001-P634SI	Valve Nova NG Hi/Lo 0820634
-------------	-----------------------------

1001-P713SI	Pilot Burner LP 199.713 TC SIT
-------------	--------------------------------

1001-P714SI Pilot Burner NG 199.714 TC SIT

### **IPI Electronic Ignition Parts**

1006-P002SI	IPI Valve System HI/LO [NG]
1006-P003SI	IPI Valve System HI/LO [LP]
1002-P047SI	Pilot Assembly [LP]
1002-P033SI	Pilot Assembly [NG]
1002-P017SI	Spark Electrode with Wire
1002-P903SI	Electrode Flame Sensor
1002-P302SI	IPI Main Module Board
1002-P850SI	AC Wall Adapter
1002-P12BH	Battery Pack
1002-P912SI	Wiring Harness
1001-P166SI	IPI Pilot Orifice #62 [NG]
1001-P168SI	IPI Pilot Orifice #35 [LP]
1002-P013SI	Modulating Servo Motor [NG]
1002-P012SI	Modulating Servo Motor [LP]
1002-P016SI	Manual HI/LO Regulator [NG]
1002-P014SI	Manual HI/LO Regulator [LP]

### **Miscellaneous Parts**

1000-150 GE	#Silicone GE Red IS806 #736
1000-150 MP	#Hi-Temp Millpac Sealant 840099
1000-214	#Piezo-Igniter 1244-17 MARK 21
1000-215	#PAL Nut (18mm x 1.5mm) Blk (1364.03)
1000-216	Gold Contact ON/OFF Switch
1000-255	#Orifice Brass - #35 Natural Gas
1000-255	#Orifice Brass - #51 Liquid Propane
350-EMBER	#Embers
DVI26-310	#Ceramic Robax Glass (For IDV26 – 27-1/2" x 17-1/4")
2000-080	#Thermodisc 2450 (For Blower)
2000-085	#Control Variable Speed KBWC-13BV
26IDV-106A	#Adapter Plate Complete –IDV26
26IDV-301	Door Frame IDV26
33IDV-123	#Replacement Spring for Door Latch (Lower)
36HB-123	#Replacement Spring for Door Latch (Upper)
33IDV-123A	Latch Assembly (Lower)
33IDV-123AU	Latch Assembly (Upper)
OFP42SA	Spark Assist
FP15GC	Stainless Steel Gas Connector

### **IDV26 Venting**

<b>Part No.</b>	<b>Description</b>
IDVVT36	Vertical Termination – Collinear 3"/3"
IDVFK25	3" Diameter [2Ea] Unexpanded 25ft Flex Pipe, Screws/Washers, Millpac
IDVLCP	Lower Chase Sealant Plate
ZDV3FC	Flex Connectors 3" Diameter



## LIMITED LIFETIME WARRANTY

This Limited Lifetime Warranty applies only while the unit remains at the site of the original installation and only if the unit is installed inside the continental United States, Alaska, Hawaii, and Canada. The warranty applies only if the unit is installed and operated in accordance with the printed instructions and in compliance with applicable installation and building codes and good trade practices.

### BASIC ONE YEAR WARRANTY

During the first year after installation of the appliance, we will provide a replacement for any component part of your unit found to be defective in materials or workmanship, including labour costs. Repair work requires prior approval by Kingsman, labour costs are based on a predetermined rate schedule and any repair work must be done through an authorized Kingsman dealer.

(Excluded Components: Accent Light Bulbs, Gasketing and Paint)

### LIMITED LIFETIME WARRANTY

The heat exchanger, combustion chamber and burner of every Kingsman product excluding the Outdoor Firepit are warranted against materials or workmanship during the period the product is owned by the original owner. The part to be replaced must be returned to our distributor in exchange for the replacement part. Any labor, material, freight and/or handling charges associated with any repair or replacement pursuant to this Limited Lifetime Warranty will not be covered by this warranty.

### GENERAL TERMS

In lieu of providing a replacement part, we may, at our option, provide the distributor's component purchase price from us or a credit equal to the distributor's component purchase price from us toward the purchase of any new unit which we distribute. If a credit is given in lieu of a replacement part, the rating plate from the unit being replaced must be submitted on a warranty claim, and the unit being replaced must be made available to our distributor for disposition.

In establishing the date of installation for any purpose, including determination of the starting date for the term of this Limited Lifetime Warranty, reasonable proof of the original installation date must be presented\*, otherwise the effective date will be based upon the date of manufacture plus thirty (30) days.

We will not be responsible for and you, the user, will pay for: (a) damages caused by accident, abuse, negligence, misuse, riot, fire, flood, or Acts of God (b) damages caused by operating the unit where there is a corrosive atmosphere containing chlorine, fluorine, or any other damaging chemicals (other than in a normal residential environment) (c) damages caused by any unauthorized alteration or repair of the unit affecting its stability or performance (d) damages caused by improper matching or application of the unit or the unit's components (e) damages caused by failing to provide proper maintenance and service to the unit (f) any expenses incurred for erecting, disconnecting or dismantling the unit (g) parts or supplies used in connection with service or maintenance (h) damage repairs, inoperation or inefficiency resulting from faulty installation or application (i) electricity or fuel costs or any increase in electricity or fuel cost whatsoever including additional or unusual use of supplemental electric heat.

We shall not be liable for any incidental, consequential, or special damages or expenses in connection with any use or failure of this unit. We have not made and do not make any representation or warranty of fitness for a particular use or purpose, and there is no implied condition of fitness for a particular use or purpose. We make no express warranties except as stated in this Limited Lifetime Warranty. No one is authorized to change this Limited Lifetime Warranty or to create for us any other obligation or liability in connections with this unit. Any implied warranties shall last for one year after the original installation. Some states and provinces do not allow the exclusion or limitation of incidental or consequential damages or do not allow limitations on how long an implied warranty or condition lasts, so the above limitations or exclusions may not apply to you. The provisions of this limited warranty are in additions to and not a modification of or subtraction from any statutory warranties and other rights and remedies provided by law.

Save this certificate. It gives you specific legal rights, and you may also have other rights which may vary from state to state and province to province.

In the event your unit needs servicing, contact your dealer or contractor who installed or serviced your unit. When requesting service, please have the model and serial number from each unit readily available. If your dealer needs assistance, the distributor is available for support and we, in turn support the distributor's efforts.

Fill in the installation date and model and serial numbers of the unit in the space provided below and retain this limited warranty for your files.

Model No. \_\_\_\_\_ Serial No. \_\_\_\_\_ Date installed \_\_\_\_\_

Dealer or Contractor Name: \_\_\_\_\_

\*To receive advantage of your warranty, you must retain the original records that can establish the installation date of your unit.