



# INSTALLATION MANUAL

## Ascent™ BX36

### SAFETY INFORMATION

#### ! WARNING

##### FIRE OR EXPLOSION HAZARD

Failure to follow safety warnings exactly could result in serious injury, death, or property damage.

- Do not store or use gasoline or other flammable vapors and liquids in the vicinity of this or any other appliance.

##### - WHAT TO DO IF YOU SMELL GAS:

- Do not try to light any appliance.
- Do not touch any electrical switch; do not use any phone in your building.
- Immediately call your gas supplier from a neighbour's phone. Follow the gas supplier's instructions.
- If you cannot reach your gas supplier, call the fire department.

- Installation and service must be performed by a qualified installer, service agency, or the supplier.

This appliance may be installed in an aftermarket, permanently located, manufactured home (USA only) or mobile home, where not prohibited by local codes.

This appliance is only for use with the type of gas indicated on the rating plate. This appliance is not convertible for use with other gases, unless a certified kit is used.

##### INSTALLER:

Leave this manual with the appliance

##### CONSUMER:

Retain this manual for future reference

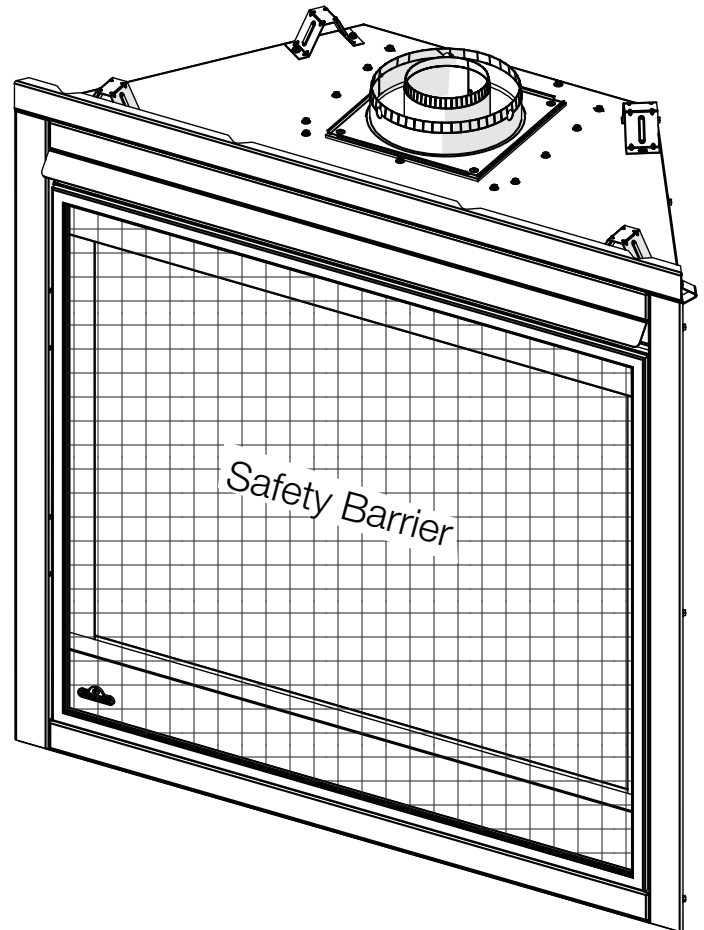

**FOR INDOOR USE ONLY**

**CERTIFIED TO THE CANADIAN AND AMERICAN NATIONAL STANDARDS:  
CSA 2.22 AND ANSI Z21.50 FOR VENTED DECORATIVE GAS APPLIANCES**



**PLACE BARCODE LABEL ON THE  
OWNER'S MANUAL**

Wolf Steel Ltd., 24 Napoleon Rd., Barrie, ON, L4M 0G8 Canada / 103 Miller Drive, Crittenden, Kentucky, USA, 41030  
Phone 1 (866) 820-8686 • www.napoleon.com • hearth@napoleon.com

## ! WARNING

- **This appliance is hot when operated and can cause severe burns if contacted.**
- **Any changes or alterations to this appliance or its controls can be dangerous and is prohibited.**
- Do not operate appliance before reading and understanding operating instructions. Failure to operate appliance according to operating instructions could cause fire or injury.
- Ensure the glass door is opened or removed when lighting the pilot for the first time and when the gas supply has run out.
- Risk of fire or asphyxiation, do not operate appliance with fixed glass removed and never obstruct the front opening of the appliance.
- Do not connect 110 volts to the control valve, with the exception of models; GSST8 and GT8.
- Risk of burns. The appliance should be turned off and cooled before servicing.
- Do not install damaged, incomplete or substitute components.
- Risk of cuts and abrasions. Wear protective gloves, protective footwear, and safety glasses during installation. Sheet metal edges may be sharp.
- Do not burn wood or other materials in this appliance.
- Provide adequate ventilation and combustion air. Provide adequate accessibility clearance for servicing and operating the appliance.
- High pressure will damage valve. Disconnect gas supply piping before pressure testing gas line at test pressures above 1/2 psig. Close the manual shut-off valve before pressure testing gas line at test pressures equal to or less than 1/2 psig (35mb).
- The appliance must not be operated at temperatures below freezing (32°F / 0°C). Allow the appliance to warm to above freezing prior to operation, with the exception of models; GSS36, GSS42; these appliances are suitable for 0°F / -18°C.
- **Children and adults should be alerted to hazards of high surface temperature and should stay away to avoid burns or clothing ignition.**
- **Young children should be carefully supervised when they are in the same room as the appliance. Toddlers, young children and others may be susceptible to accidental contact burns. A physical barrier is recommended if there are at risk individuals in the house. To restrict access to an appliance or stove, install an adjustable safety gate to keep toddlers, young children and other at risk individuals out of the room and away from hot surfaces.**
- **Clothing or other flammable material should not be placed on or near the appliance.**
- **Due to high temperatures, the appliance should be located out of traffic and away from furniture and draperies.**
- Furniture or other objects must be kept a minimum of 4 feet (1.22m) away from the front of the appliance.
- Ensure you have incorporated adequate safety measures to protect infants/toddlers from touching hot surfaces.
- Even after the appliance is off, it will remain hot for an extended period of time.
- Check with your local hearth specialty dealer for safety screens and hearth guards to protect children from hot surfaces. These screens and guards must be fastened to the floor.
- **Any safety screen, guard or barrier removed for servicing the appliance, must be replaced prior to operating the appliance.**
- It is imperative that the control compartments, burners and circulating blower and its passageway in the appliance and venting system are kept clean. The appliance and its venting system should be inspected before use and at least annually by a qualified service person. More frequent cleaning may be required due to excessive lint from carpeting, bedding material, etc. The appliance area must be kept clear and free from combustible materials, gasoline and other flammable vapors and liquids.
- If the appliance shuts off, do not re-light until you provide fresh air. If appliance keeps shutting off, have it serviced. Keep burner and control compartment clean.
- Under no circumstances should this appliance be modified.
- Do not allow wind or fans to blow directly into the appliance. Avoid any drafts that alter burner flame patterns.

# DANGER

**HOT GLASS WILL CAUSE BURNS.**

**DO NOT TOUCH GLASS UNTIL COOLED.**

**NEVER ALLOW CHILDREN TO TOUCH GLASS.**

A barrier designed to reduce the risk of burns from the hot viewing glass is provided with this appliance and must be installed for the protection of children and other at-risk individuals.

**! WARNING**

- Do not use a blower insert, heat exchanger insert or other accessory not approved for use with this appliance.
- This appliance must not be connected to a chimney flue pipe serving a separate solid fuel burning appliance.
- Do not use this appliance if any part has been under water. Immediately call a qualified service technician to inspect the appliance and to replace any part of the control system and any gas control which has been under water.
- Do not operate the appliance with the glass door removed, cracked or broken. Replacement of the glass should be done by a licensed or qualified service person, if equipped.
- Do not strike or slam shut the appliance glass door, if equipped.
- **Only doors / optional fronts certified with the appliance are to be installed on the appliance.**
- Keep the packaging material out of reach of children and dispose of the material in a safe manner. As with all plastic bags, these are not toys and should be kept away from children and infants.
- Carbon or soot should not occur in a vent free appliance as it can distribute into the living area of your home. If you notice any signs of carbon or soot, immediately turn off your appliance and arrange to have it serviced by a qualified technician before operating it again.
- If equipped, the screen must be in place (closed) when the appliance is in operation.
- When equipped with pressure relief doors, they must be kept closed while the appliance is operating to prevent exhaust fumes containing carbon monoxide, from entering into the home. Temperatures of the exhaust escaping through these openings can also cause the surrounding combustible materials to overheat and catch fire.
- Carbon monoxide poisoning may lead to death; early signs of carbon monoxide poisoning resemble the flu, with headache, dizziness and/or nausea. If you have these signs, the appliance may not be working properly. Get fresh air at once! Have appliance serviced. Some people; pregnant women, persons with heart or lung disease, anemia, those under the influence of alcohol, those at high altitudes are more affected by carbon monoxide than others. Failure to keep the primary air opening(s) of the burner(s) clean may result in sooting and property damage.
- As with any combustion appliance, we recommend having your appliance regularly inspected and serviced as well as having a Carbon Monoxide Detector installed in the same area to defend you and your family against Carbon Monoxide (not applicable for outdoor appliances).
- Ensure clearances to combustibles are maintained when building a mantel or shelves above the appliance. Elevated temperatures on the wall or in the air above the appliance can cause melting, discolouration or damage to decorations, a TV or other electronic components.
- **For appliances equipped with a safety barrier; if the barrier becomes damaged, the barrier shall be replaced with the manufacturer's barrier for this appliance.**
- **Installation and repair should be done by a qualified service person. It is imperative that control compartments, burners and circulating air passageways of the appliance be kept clean.**
- For outdoor products only: this appliance must not be installed indoors or within any structure that prevents or inhibits the exhaust gases from dissipating in the outside atmosphere.
- If applicable, the millivolt version of this appliance uses and requires a fast acting thermocouple. Replace only with a fast acting thermocouple supplied by Wolf Steel Ltd.

**! WARNING:** This product can expose you to chemicals including lead and lead compounds, which are known to the State of California to cause cancer, and chemicals including carbon monoxide, which are known to the State of California to cause birth defects or other reproductive harm. For more information, go to [www.P65Warnings.ca.gov](http://www.P65Warnings.ca.gov).

**! WARNING !**

**FIRE RISK HAZARD / DELAYED IGNITION**

**High supply pressure will damage the valve / controls.**



Disconnect the appliance main gas valve/control from the supply piping when pressure testing that system at pressures in excess of 1/2 psi (3.5 kPa).

Isolate the appliance with it's shut off valve during any pressure testing of the supply piping at pressures equal to or less than 1/2 psi (3.5 kPa).

# table of contents

<b>1.0</b>	<b>general information</b>	<b>5</b>	5.3	electronic wiring diagram	42
1.1	rates and efficiencies	5	5.4	battery back-up installation	43
1.2	installation overview	6	5.5	initializing the transmitter for the first time	44
1.3	rating plate information	8	5.6	wiring diagram	45
1.4	mobile home installation	8	5.7	light & blower assembly wiring diagrams	46
1.5	dimensions	9	<b>6.0</b>	<b>gas installation</b>	<b>47</b>
1.6	optional heat management system	10	<b>7.0</b>	<b>nauling tab installation</b>	<b>47</b>
<b>2.0</b>	<b>venting requirements</b>	<b>11</b>	<b>8.0</b>	<b>operation</b>	<b>48</b>
2.1	typical vent installation	12	8.1	pilot on demand	49
2.2	special vent installations	14	<b>9.0</b>	<b>finish framing</b>	<b>50</b>
2.2.1	periscope termination	14	9.1	flush	50
2.2.2	corner termination	14	9.2	recess	51
2.3	minimum air terminal location clearances	15	<b>10.0</b>	<b>finishing</b>	<b>52</b>
2.4	venting application flow chart	16	10.1	safety barrier / door removal and installation	52
2.5	definitions	16	10.2	front hood installation	53
2.6	elbow vent length values	17	10.3	non-combustible facing material	54
2.7	top exit horizontal termination	17	10.4	minimum mantel clearances	55
2.8	rear exit horizontal termination	19	10.5	clearances around appliance (TV and valuable objects)	56
2.9	top and rear exit vertical termination	21	10.6	log placement	57
2.10	rear exit	23	10.7	glowing embers	59
2.11	rear exit shield (for rear vent only)	24	10.8	charcoal embers	59
2.12	top exit	25	10.9	logo placement	59
<b>3.0</b>	<b>rough framing</b>	<b>26</b>	10.10	glass media placement	59
3.1	minimum framing dimensions	27	<b>11.0</b>	<b>adjustments</b>	<b>60</b>
3.2	minimum enclosure clearances	28	11.1	pilot burner adjustment	60
<b>4.0</b>	<b>venting installation</b>	<b>33</b>	11.2	venturi adjustment	60
4.1	horizontal installation	34	11.3	flame characteristics	61
4.2	vertical installation	35	<b>12.0</b>	<b>maintenance</b>	<b>62</b>
4.3	using either flexible or rigid vent components	36	12.1	annual maintenance	62
4.3.1	horizontal air terminal installation	36	12.2	door glass replacement	63
4.3.2	vertical air terminal installation	37	12.3	care of glass	63
4.3.3	appliance vent connection	37	12.4	night light replacement	64
4.3.4	horizontal air terminal installation	38	12.5	blower replacement	64
4.3.5	vertical air terminal installation	39	<b>13.0</b>	<b>replacement parts</b>	<b>65</b>
4.4	vertical through existing chimney	40	13.1	overview	66
4.4.1	restricting vertical vents	41	13.2	valve train assembly	67
<b>5.0</b>	<b>electrical information</b>	<b>42</b>	<b>14.0</b>	<b>troubleshooting</b>	<b>68</b>
5.1	hard wiring connection	42	<b>15.0</b>	<b>warranty</b>	<b>71</b>
5.2	receptacle wiring diagram	42			

## note:

The information throughout this manual is believed to be correct at the time of printing. Wolf Steel Ltd. reserves the right to change or modify any information within this manual at any time without notice. Changes, other than editorial, are denoted by a vertical line in the margin.



# Installer: please fill out appliance checklist in the Owner's manual.

## 1.0 general information

When the appliance is installed at elevations above 4,500ft (1372m), and in the absence of specific recommendations from the local authority having jurisdiction, the certified high altitude input rating shall be reduced at the rate of 4% for each additional 1,000ft (305m). Expansion / contraction noises during heating up and cooling down cycles are normal and are to be expected. Change in flame appearance from “HI” to “LO” is more evident in natural gas than in propane.

This appliance is approved for bathroom, bedroom and bed-sitting room installations and is certified for mobile home installation.

**This appliance is only for use with the type of gas indicated on the rating plate. This appliance is not convertible for use with other gases, unless a certified kit is used.**

**note:**

**A barrier designed to reduce the risk of burns from the hot viewing glass is provided with the appliance and must be installed.**

The protective wrap on plated parts is best removed when the assembly is at room temperature but this can be improved if the assembly is warmed, using a hair dryer or similar heat source.

**This appliance is a decorative product. It is not a source of heat and not intended to burn solid fuel.**



Batteries must be disposed of according to the local laws and regulations. Some batteries may be recycled, and may be accepted for disposal at your local recycling center. Check with your municipality for recycling instructions.

## 1.1 rates and efficiencies

Fuel Type	Natural Gas	Propane
Altitude (FT)	0-4,500	
Max. Input (BTU/hr)	26,000	25,000
Min. Inlet Gas Supply Pressure	4.5" w.c. (11mb)	11" w.c. (27mb)
Max. Inlet Gas Supply Pressure	7" w.c. (17mb)*	13" w.c. (32mb)
Manifold Pressure (Under Flow Confictions)	3.5" w.c. (9mb)	10" w.c. (25mb)

\*Max. inlet pressure not to exceed 13" w.c. (32mb).

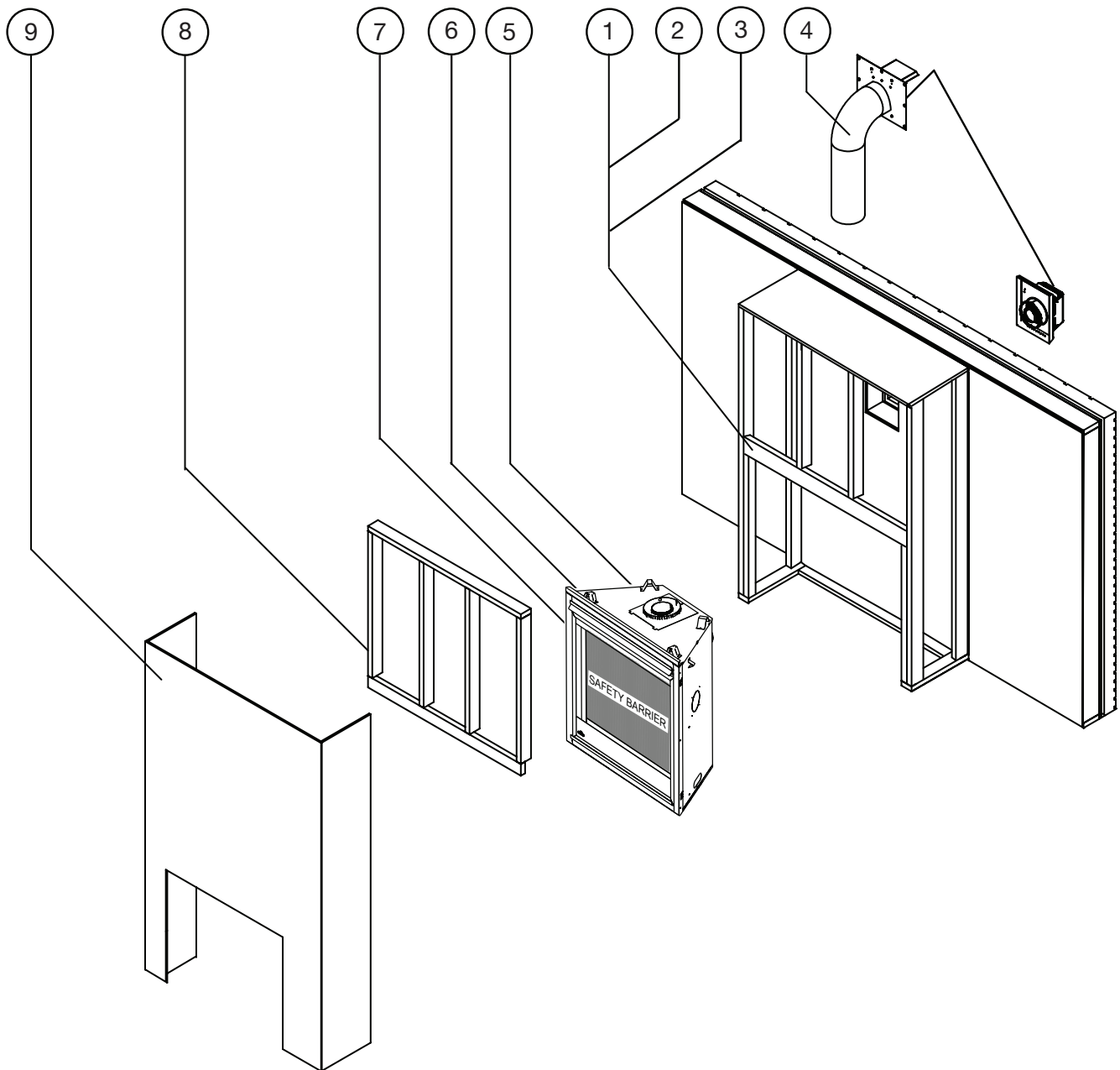

### Recommended installation steps:

1. Determine venting requirements before deciding the final location of the appliance.
2. Install rough framing (see “rough framing” section).

#### note:

For Universal Heat Management installation steps, refer to the leaflet provided with the Universal Heat Management kit. Start Universal Heat Management installation before placing appliance in its final position.

3. Place the appliance in its final position.
4. Install appliance venting (see “venting installation” section).
5. Install all electrical wirings (see “electrical information” section).
6. Install gas lines (see “gas installation” section).
7. Test appliance.
8. Complete framing (see “finish framing” section).
9. Complete finishing (see “finishing” section).

**! WARNING**

- Always light the pilot whether for the first time or if the gas supply has run out, with the glass door opened or removed.
- Provide adequate clearance for servicing and operating the appliance.
- Provide adequate ventilation.
- Never obstruct the front opening of the appliance.
- Objects placed in front of the appliance must be kept a minimum of 48" (121.9cm) from the front face of the appliance.
- Surfaces around and especially above the appliance can become hot. Avoid contact when appliance is operating.
- Fire risk. Explosion hazard.
- High pressure will damage valve. Disconnect gas supply piping before pressure testing gas line at test pressures above 1/2 PISG (35mb). Close the manual shut-off valve before pressure testing gas line at test pressures equal to or less than 1/2 PISG (35mb).
- Use only Wolf Steel approved optional accessories and replacement parts with this appliance using non-listed accessories (blowers, doors, louvres, trims, gas components, venting components, etc.) could result in a safety hazard and will void the warranty and certification.
- The appliance must not be operated at temperatures below freezing (32°F/0°C). Allow the appliance to warm to above freezing prior to operation.

**THIS GAS APPLIANCE MUST BE INSTALLED AND SERVICED BY A QUALIFIED INSTALLER** to conform with local codes. Installation practices vary from region to region and it is important to know the specifics that apply to your area, for example in the state of Massachusetts:

- This product must be installed by a licensed plumber or gas fitter when installed within the commonwealth of Massachusetts.
- The appliance damper must be removed or welded in the open position prior to installation of an appliance insert or gas log.
- The appliance off valve must be a "T" handle gas cock.
- The flexible connector must not be longer than 36 inches (0.9m).
- A carbon monoxide detector is required in all rooms containing gas fired appliances.
- The appliance is not approved for installation in a bedroom or bathroom unless the unit is a direct vent sealed combustion product.

The installation must conform with local codes or, in absence of local codes, the National Gas and Propane Installation Code CSA B149.1 in Canada, or the National Fuel Gas Code, ANSI Z223.1 / NFPA 54 in the United States. Suitable for mobile home installation if installed in accordance with the current standard CAN/CSA Z240MH Series, for gas equipped mobile homes, in Canada or ANSI Z223.1 and NFPA 54 in the United States.

The appliance and its individual shutoff valve must be disconnected from the gas supply piping system during any pressure testing of that system at test pressures in excess of 1/2 psig (35 mb).

The appliance must be isolated from the gas supply piping system by closing its individual manual shutoff valve during any pressure testing of the gas supply piping system at test pressures equal to or less than 1/2 psig (35 mb). When installed with a blower or fan, the junction box must be electrically connected and grounded in accordance with local codes. In the absence of local codes, use the current CSA C22.1 Canadian Electrical Code in Canada or the ANSI / NFPA 70 National Electric Code in the United States. In the case where the blower is equipped with a power cord, it must be connected into a properly grounded receptacle. The grounding prong must not be removed from the cord plug.

The following does not apply to inserts; as long as the required clearance to combustibles is maintained, the most desirable and beneficial location for an appliance is in the center of a building, thereby allowing the most efficient use of the heat created. The location of windows, doors and, the traffic flow in the room where the appliance is to be located should be considered. If possible, you should choose a location where the vent will pass through the house without cutting a floor or roof joist. If the appliance is installed directly on carpeting, vinyl tile or other combustible material other than wood flooring, the appliance shall be installed on a metal or wood panel extending the full width and depth, unless otherwise tested.



We suggest that our gas hearth products be installed and serviced by professionals who are certified in the U.S. by the National Fireplace Institute® (NFI) as NFI Gas Specialists

# general information

## 1.3 rating plate information

Certified to Canadian and American National Standards: **CSA 2.22-XXXX / ANSI Z21.50-XXXX for Vented Decorative Gas Appliances**  
 Certifié selon les normes Nationales Canadiennes et Américaines: **CSA 2.22-XXXX / ANSI Z21.50-XXXX pour les Appareils à gaz décoratif à évacuation**

Direct vent, vented gas fireplace. Approved for bedroom, bathroom and bed-sitting room installation. Suitable for mobile home installation, if installed in accordance with the current standard CAN / CSA Z240MH Series gas equipped mobile homes in Canada, or, in the United States, the *Manufactured Home Construction and Safety Standard, Title 24 CFR, Part 3280*. When this US Standard is not applicable, use the *Standard for Fire Safety Criteria for Manufactured Home Installations, Sites and Communities, ANSI / NFPA 501A*. This appliance must be installed in accordance with local codes, if any; if none, follow the current ANSI Z223.1 or CSA B149. **For use with barrier WXXX-XXXX. Follow installation instructions.**  
 Foyer à gaz ventilé. Homologué pour installation dans une chambre à coucher, une salle de bain et un studio. Approuvé pour installation dans une maison mobile si son installation conforme aux exigences de la norme CAN / CSA Z240MH Série de maisons mobile équipées au gaz en vigueur au Canada, ou, aux États-Unis selon la norme *24 CFR, Part 3280, Manufactured Home Construction and Safety Standard*. Dans le cas où cette norme d'États-Unis n'est pas pertinente, utiliser la norme *NFPA 501A, Fire Safety Criteria for Manufactured Home Installations, Sites and Communities*. Installer l'appareil selon les codes ou règlements locaux ou, en l'absence de tels règlements, selon les codes d'installation ANSI Z223.1 ou CSA B149 en vigueur. **Utiliser uniquement avec l'écran WXXX-XXXX. Suivre les instructions d'installation.**

**REFERENCE# 161746**

9700539 (WSL)     4001658 (NAC)     4001657 (NGZ)     4001659 (WUSA)

**MODEL / MODÈLE**

XXXX     XXXX     XXXX     XXXX  
 XXXX     XXXX     XXXX     XXXX

Altitude Input     XXXX     XXXX     XXXX     XXXX  
 Reduced Input     XXXX     XXXX     XXXX     XXXX

Manifold Pressure: 3.5" w.c. (NG)     XXXX     XXXX     XXXX     XXXX  
 Minimum Supply Pressure: 4.5" w.c. (NG)     XXXX     XXXX     XXXX     XXXX  
 Maximum Supply Pressure: 7" w.c. (NG)     XXXX     XXXX     XXXX     XXXX

Pression au Collecteur: 3.5" d'une colonne d'eau (GN)     XXXX     XXXX     XXXX     XXXX  
 Pression d'Alimentation Min.: 4.5" d'une colonne d'eau (GN)     XXXX     XXXX     XXXX     XXXX  
 Pression d'Alimentation Max.: 7" \*\* d'une colonne d'eau (GN)     XXXX     XXXX     XXXX     XXXX

Manifold Pressure: 10" w.c. (P)     XXXX     XXXX     XXXX     XXXX  
 Minimum Supply Pressure: 11" w.c. (P)     XXXX     XXXX     XXXX     XXXX  
 Maximum Supply Pressure: 13" w.c. (P)     XXXX     XXXX     XXXX     XXXX

Pression au Collecteur: 10" d'une colonne d'eau (P)     XXXX     XXXX     XXXX     XXXX  
 Pression d'Alimentation Min.: 11" d'une colonne d'eau (P)     XXXX     XXXX     XXXX     XXXX  
 Pression d'Alimentation Max.: 13" \*\* d'une colonne d'eau (P)     XXXX     XXXX     XXXX     XXXX

\*\* Maximum inlet pressure not to exceed 13"  
 \*\* Pression d'alimentation maximale ne devrait pas dépasser 13"

**Minimum clearance to combustible materials:**  
 Top, sides & back: per standoff spacers for framing and finishing materials. For non-combustible framing and finishing materials, see installation manual.  
 Dessus, côtés et arrière: selon les espacements de dégagements pour les matériaux d'ossature selon le manuel du propriétaire pour les matériaux de finition.

Top X"    Dessus X"  
 Floor X"    Plancher X"  
 Sides X"    Côtés X"  
 Back X"    Arrière X"

Vent top X"    Dessus du conduit d'évent X"  
 Vent sides & bottom X"    Côtés et dessous du conduit d'évent X"  
 Recessed depth X"    Profondeur d'encastrement face X"

\*\*\* Mantel X" from appliance opening  
 \*\*\* Tablette X" de l'ouverture de l'appareil

\*\*\*\* Maximum horizontal extension:  
 \*\*\*\* Extension horizontale maximale: X"  
 X": See installation manual for greater extensions, minimum vent lengths and maximum vent lengths.  
 Référez au manuel d'installation pour des extensions plus grandes, les longueurs d'évacuation minimales et maximum.

Electrical rating: 115V, 60HZ. Less than 12 amperes.  
 Spécifications électriques: 115V, 60HZ. Moins de 12 ampères.

**VENTED DECORATIVE GAS APPLIANCE: NOT A SOURCE OF HEAT, NOT INTENDED FOR USE AS A HEATING APPLIANCE, NOT FOR USE WITH SOLID FUEL.**  
**APPAREIL À GAZ DÉCORATIF À ÉVACUATION: N'EST PAS UNE SOURCE DE CHALEUR; N'EST PAS DESTINÉ À ÊTRE UTILISÉ COMME UN APPAREIL DE CHAUFFAGE; NE CONVIENT PAS AUX COMBUSTIBLES SOLIDES.**

**FOR USE WITH GLASS DOORS CERTIFIED WITH THIS APPLIANCE ONLY. POUR UTILISATION UNIQUEMENT AVEC LES PORTES EN VERRE CERTIFIÉES AVEC L'APPAREIL.**

For natural gas when equipped with No. XX drill size orifice.  
 For propane when equipped with No. XX drill size orifice.  
 Convient au gaz naturel quand l'appareil est muni d'un injecteur de diamètre no. XX.  
 Convient au propane quand l'appareil est muni d'un injecteur de diamètre no. XX.

**WARNING:** Do not add any material to the appliance which will come in contact with the flames, other than that supplied by the manufacturer with the appliance.  
**AVERTISSEMENT:** N'ajoutez pas à cet appareil aucun matériau devant entrer en contact avec les flammes autre que celui qui est fourni avec cet appareil par le fabricant.

The appliance must be vented using the appropriate Napoleon vent kits. See installation manual for venting specifications. Proper reinstallation and resealing is necessary after servicing the vent-air intake system.  
 L'appareil doit être ventilé à l'aide de l'ensemble d'évacuation propre à Napoleon. Référez au manuel d'installation pour les spécifications d'évacuation. Il est nécessaire de bien réinstaller et resceller l'évacuation après avoir exécuté l'entretien du système de prise d'air.

Serial Number / N° de Série: XXXX    W385-XXXX

**WOLF STEEL LTD.** 24 Napoleon Road, Barrie, ON, L4M 0G8 Canada

This illustration is for reference only. Refer to the rating plate on the appliance for accurate information.

### note:

The rating plate must remain with the appliance at all times. It must not be removed.

## 1.4 mobile home installation

This appliance must be installed in accordance with the manufacturer's instructions and the Manufactured Home Construction and Safety Standard, Title 24 CFR, Part 3280, in the United States or the Mobile Home Standard, CAN/CSA Z240 MH Series, in Canada. This appliance is only for use with the type(s) of gas indicated on the rating plate.

This mobile/manufactured home listed appliance comes factory equipped with a means to secure the appliance. Built in appliances are equipped with 1/4" (6.4mm) diameter holes located in the front left and right corners of the base. Use appropriate fasteners, inserted through the holes in the base to secure. For free standing products contact your local authorized dealer / distributor for the appropriate securing kit. For mobile home installations, the appliance must be fastened in place. It is recommended that the appliance be secured in all installations. Always turn off the pilot and the fuel supply at the source, prior to moving the mobile home. After moving the mobile home and prior to lighting the appliance, ensure that the logs are positioned correctly.

This appliance is certified to be installed in an aftermarket permanently located, manufactured (mobile) home, where not prohibited by local codes. This appliance is only for use with the type of gas indicated on the rating plate. This appliance is not convertible for use with other gases, unless a certified kit is used.

### Conversion Kits

This appliance is field convertible between Natural Gas (NG) and Propane (P). To convert from one gas to another, consult your Authorized dealer/distributor.

1.5 dimensions

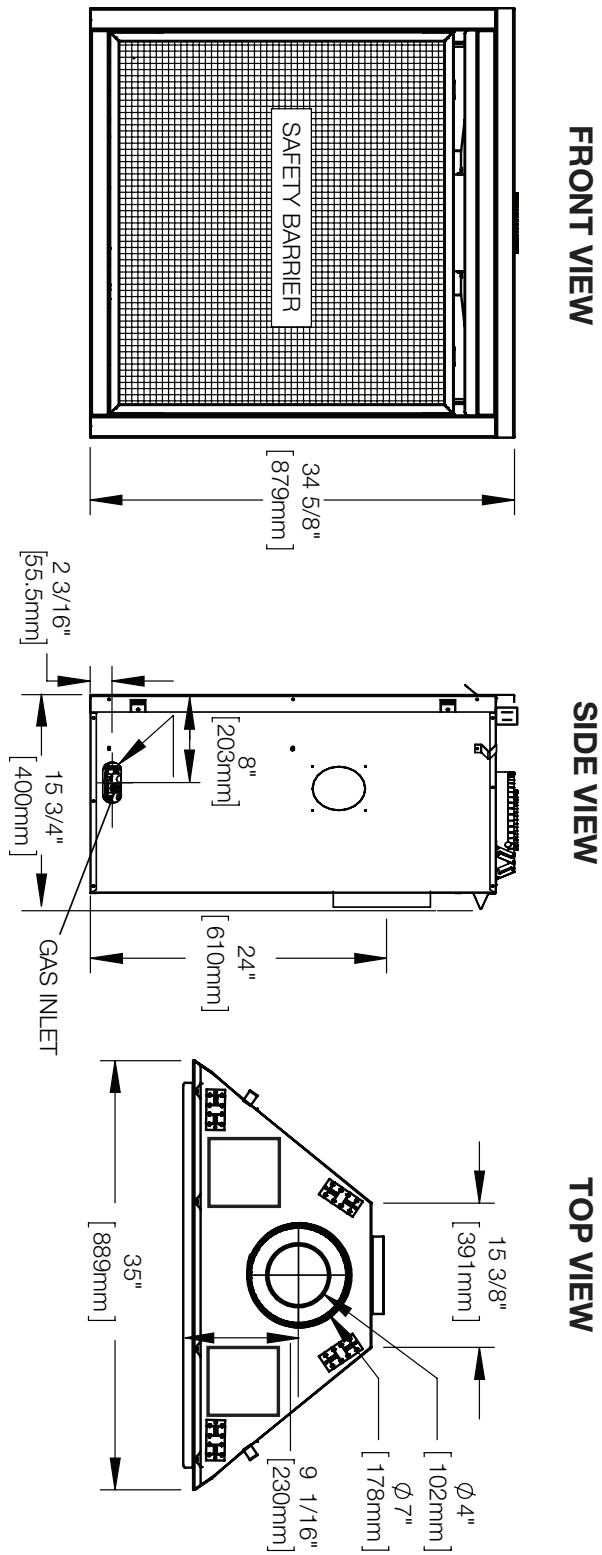



# general information

## 1.6 optional heat management system

The Universal Heat Management system is an optional gravity vent kit that allows you to manage the heat produced by the appliance at and around the fireplace.

We recommend installing the Universal Heat Management system kit during the installation of the appliance **BEFORE** the gas is installed.

For more information, contact your local authorized dealer.

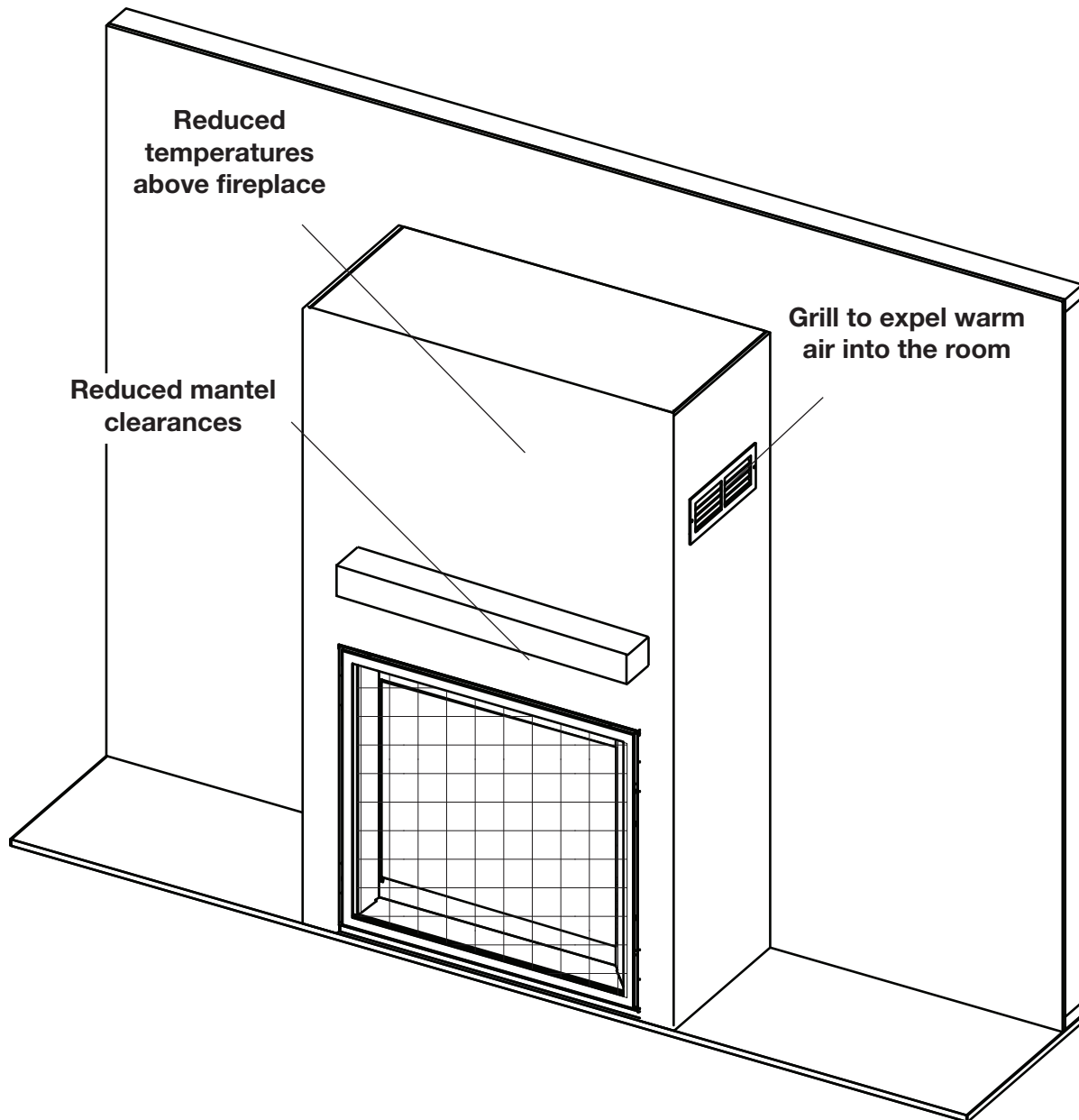

### WARNING

- Risk of fire. Maintain specified air space clearances to vent pipe and appliance.
- The vent system must be supported every 3'(0.9m) for both vertical and horizontal runs. Use support ring assembly W010-0067 or equivalent non-combustible strapping to maintain the minimum clearance to combustibles for both vertical and horizontal runs. Spacers are attached to the inner pipe at predetermined intervals to maintain an even air gap to the outer pipe. This gap is required for safe operation. A spacer is required at the start, middle, and end of each elbow to ensure this gap is maintained. These spaces must not be removed.

**This appliance uses a 4" (102mm) exhaust / 7" (178mm) air intake vent pipe system. Refer to the section applicable to your installation.**

For safe and proper operation of the appliance, follow the venting instructions exactly. Deviation from the minimum vertical vent length can create difficulty in burner start-up and/or carboning. Under extreme vent configurations, allow several minutes (5-15) for the flame to stabilize after ignition. Although not a requirement, it is recommended for vent lengths that pass through unheated spaces (attics, garages, crawl spaces) be insulated with the insulation wrapped in a protective sleeve to minimize condensation. Provide a means for visually checking the vent connection to the appliance after the appliance is installed. Use a firestop, vent pipe shield or attic insulation shield when penetrating interior walls, floor or ceiling.

The vent terminal may be painted with a high temperature paint to match exterior colours. Use an outdoor paint suitable for 400°F (200°C). Application and performance of paint is the consumer's responsibility. Spot testing is recommended.

#### note:

If for any reason the vent air intake system is disassembled, re-install per the instructions provided for the initial installation.

This appliance must be installed with a continuous connection of exhaust and air intake vent pipes. Utilizing alternate constructions such as a chimney as part of the vent system is not permitted.

Use only Wolf Steel, Metal-Fab, BDM, Simpson Dura-Vent, or Selkirk Direct Temp venting components. Minimum and maximum vent lengths, for both horizontal and vertical installations, clearances from vent pipes to combustibles and air terminal locations as set out in this manual apply to all vent systems and must be adhered to. For Metal-Fab, BDM, Simpson Dura-Vent, or Selkirk Direct Temp, follow the installation procedure provided with the venting components or on the website for your venting supplier.

A starter adaptor must be used with the following vent systems and may be purchased through Wolf Steel or from the corresponding supplier listed below:

Venting System	Manufacturer	Starter Adapter Part Number	Supplier	Website
SureSeal	Metal-Fab	4DNA	Wolf Steel	www.mtlfab.com
Direct Vent Pro	Simpson DuraVent	W175-0053	Wolf Steel	www.duravent.com
Pro-Form	BDM	DVR6-STA7	BDM	www.dalsinmfg.com
Direct Temp	Selkirk	4DT-AAN	Selkirk	www.selkirkcorp.com
Ventis	Olympia Chimney and Venting	VDV-NA04-47F	Olympia Chimney and Venting	www.olympiachimney.com

Connections made by means of an adaptor at the appliance, as well as the connection at the vent terminal must be sealed. RTV sealant may be used on both the inner exhaust and outer intake vent pipe joints of all other approved vent systems, except for the exhaust vent pipe connection to the appliance flue collar which must be sealed using the black high temperature sealant Mill Pac.

For all vent systems is strongly recommend for all installations but required when power venting the appliance, that the outer air intake joints are sealed using either high temperature silicone (RTV) or a suitable aluminum tape that covers each joint in the vent system entirely around its circumference. This will ensure the best performance in every application and avoids performance or condensation concerns that may occur in "tightly" constructed homes, particularly those in cold climates.

When using Wolf Steel venting components, use only approved Wolf Steel rigid / flexible components with the following termination kits: wall terminal kit **GD-222**, **GD-222R**, **ST47U** or 1/12 to 7/12 pitch roof terminal kit **GD-110**, 8/12 to 12/12 roof terminal kit **GD-111**, flat roof terminal kit **GD-112** or periscope kit **GD-201** (for wall penetration below grade). With flexible venting, in conjunction with the various terminations, use either the 5 foot (1.5m) vent kit **GD-220** or the 10 foot (3.1m) vent kit **GD-330**. For stoves only: wall terminal kit **GD-175** (venting included).

**For optimum flame appearance and appliance performance, keep the vent length and number of elbows to a minimum.**

**The air terminal must remain unobstructed at all times. Examine the air terminal at least once a year to verify that it is unobstructed and undamaged.**

**Rigid and flexible venting systems must not be combined. Different venting manufacturer components must not be combined.**



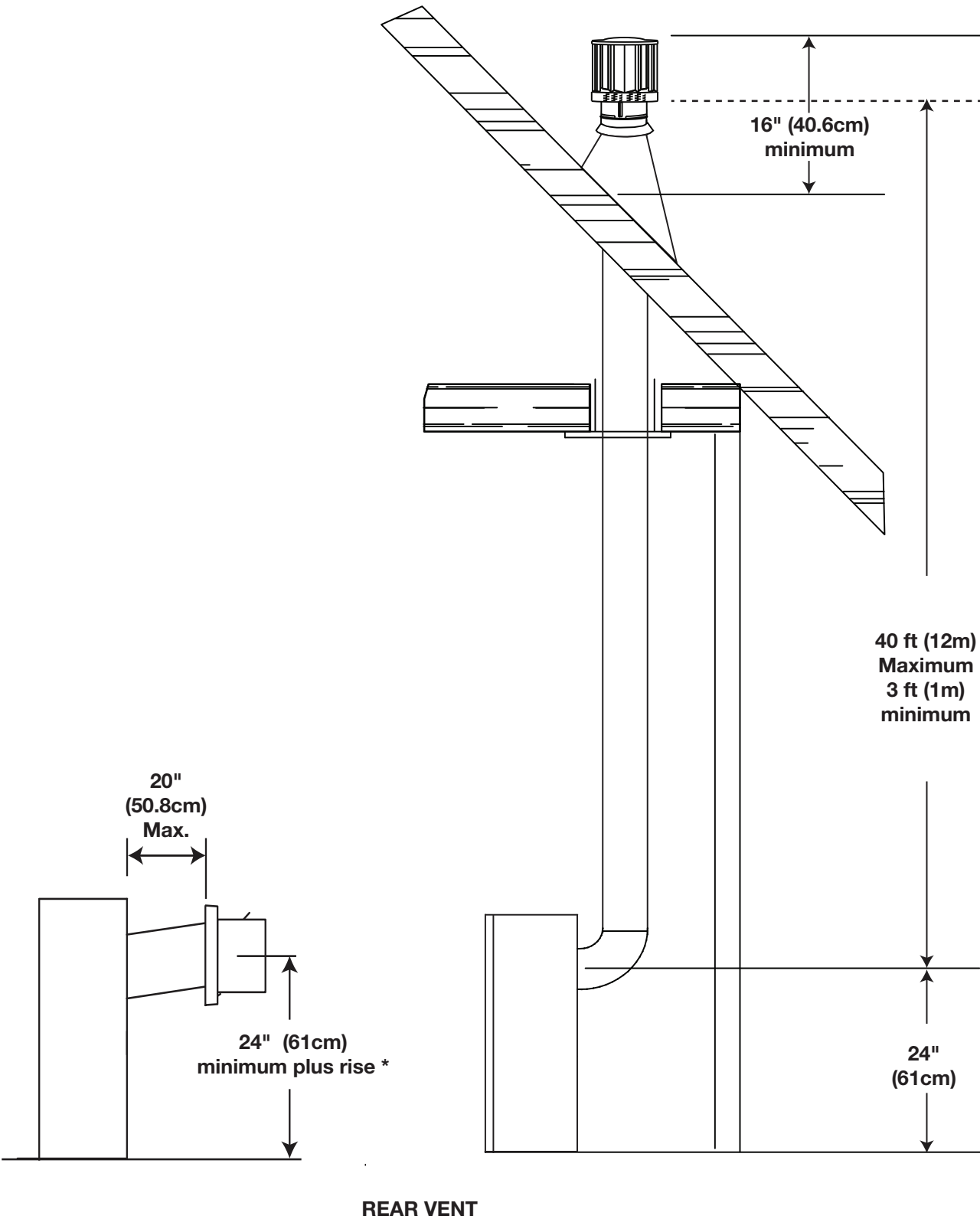

\* See "venting" section

# venting requirements

## 2.2 special vent installations

### 2.2.1 periscope termination

Use the periscope kit to locate the air termination above grade. The periscope must be installed so that when final grading is completed, the bottom air slot is located a minimum 12" (305mm) above grade. The maximum allowable vent length (including both rise and run) is 10' (3m) for a fireplace and 8' (2m) for a stove. An insulation sleeve is illustrated in the top vent image below, use only when supplied with the appliance. (The insulation sleeve is not required with a stove appliance)

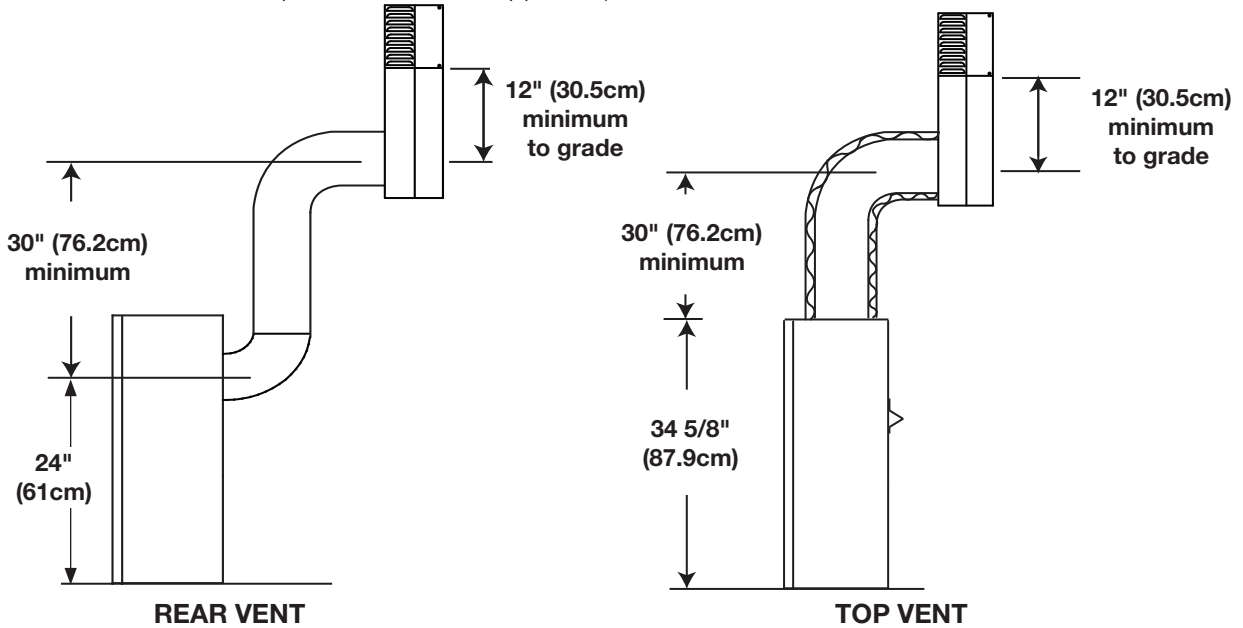

### 2.2.2 corner termination

The maximum vent length for a corner installation is 20" (50.8cm) of horizontal run, in addition to the 45° offset. In this case zero rise is acceptable. When using rigid venting, it is required to maintain a 6" (152mm) rise. When using flexible venting, see illustrations below.

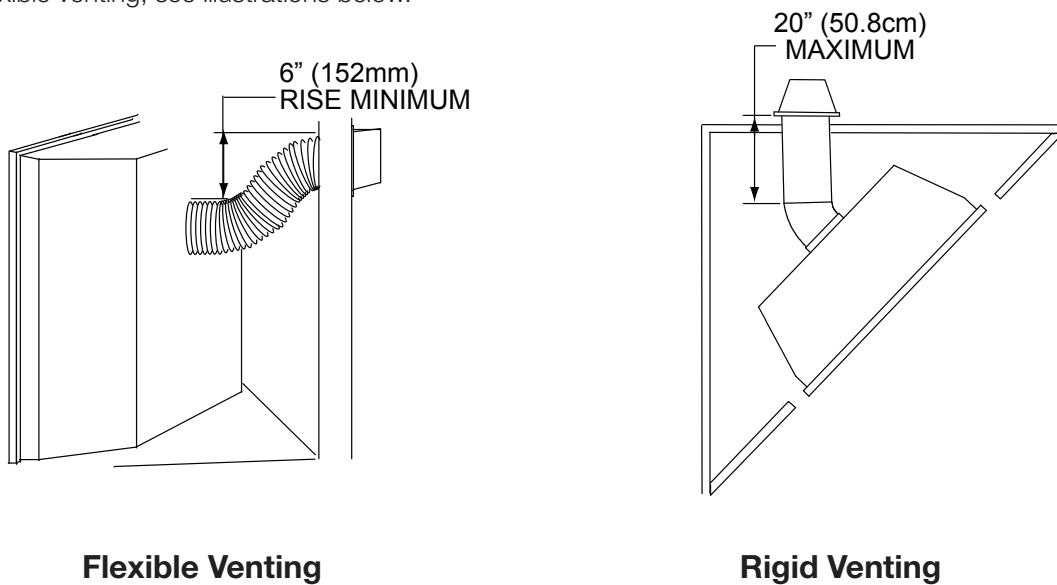

BX36-1 Required Rise	
Rear Vent Corner	6" (152mm)



**2.3 minimum air terminal location clearances**

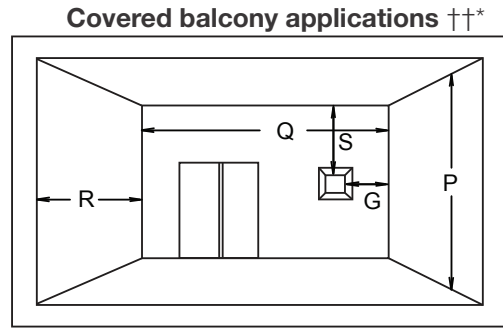
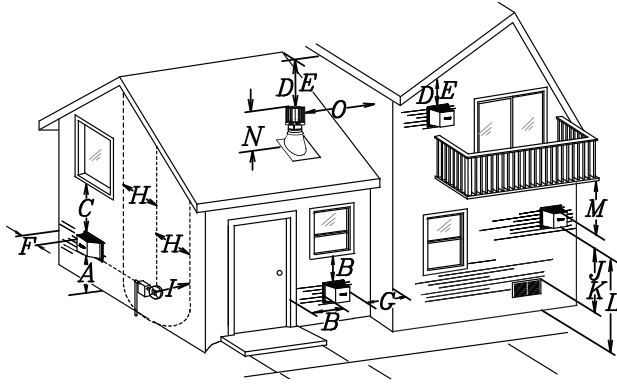

$Q_{MIN} = 3 \text{ feet}$ (0.9m)	$R_{MAX} = 2 \times Q_{ACTUAL}$	$R_{MAX} \leq 15 \text{ feet}$ (4.6m)
--------------------------------------	---------------------------------	--

	INSTALLATIONS		note:
	CANADA	U.S.A.	
<b>A</b>	12" (30.5cm)	12" (30.5cm)	Clearance above grade, veranda porch, deck or balcony.
<b>B</b>	12" (30.5cm) <sup>Δ</sup>	9" (229mm) <sup>Δ</sup>	Clearance to windows or doors that open.
<b>C</b>	12" (30.5cm)*	12" (30.5cm)*	Clearance to permanently closed windows.
<b>D</b>	18" (45.7cm)**	18" (45.7cm)**	Vertical clearance to ventilated soffits located above the terminal within a horizontal distance of 2' (0.6m) from the center line of the terminal.
<b>E</b>	12" (30.5cm)**	12" (30.5cm)**	Clearance to unventilated soffit.
<b>F</b>	0" (0mm)	0" (0mm)	Clearance to an outside corner wall.
<b>G</b>	0" (0mm)***	0" (0mm)***	Clearance to an inside <b>non</b> -combustible corner wall or protruding <b>non</b> -combustible obstructions (chimney, etc.).
	2" (51mm)***	2" (51mm)***	Clearance to an inside combustible corner wall or protruding combustible obstructions (vent chase, etc.).
<b>H</b>	3'(0.9m)	3'(0.9m)****	Clearance to each side of the center line extended above the meter / regulator assembly to a maximum vertical distance of 15' (4.6m).
<b>I</b>	3' (0.9m)	3' (0.9m)****	Clearance to a service regulator vent outlet.
<b>J</b>	12" (30.5cm)	9" (229mm)	Clearance to a non-mechanical air supply inlet to the building or a combustion air inlet to any other appliance.
<b>K</b>	6' (1.8m)	3' (0.9m) †	Clearance to a mechanical air supply inlet.
<b>L</b>	7' (2.1m) ‡	7' (2.1m) ****	Clearance above a paved sidewalk or paved driveway located on public property.
<b>M</b>	12" (30.5cm)††	12" (30.5cm)****	Clearance under a veranda, porch, deck or overhang.
<b>N</b>	16" (40.6cm)	16" (40.6cm)	Clearance above the roof.
<b>O</b>	2' (0.6m)†*	2' (0.6m) †*	Clearance from an adjacent wall including neighbouring buildings.
<b>P</b>	8' (2.4m)	8' (2.4m)	Roof must be <b>non</b> -combustible without openings.
<b>Q</b>	3' (0.9m)	3' (0.9m)	See chart for wider wall dimensions.
<b>R</b>	6' (1.8m)	6' (1.8m)	See chart for deeper wall dimensions. The terminal shall not be installed on any wall that has an opening between the terminal and the open side of the structure.
<b>S</b>	12" (30.5cm)	12" (30.5cm)	Clearance under a covered balcony

Δ The terminal shall not be located less than 6 feet under a window that opens on a horizontal plane in a structure with three walls and a roof.

\* Recommended to prevent condensation on windows and thermal breakage

\*\* It is recommended to use a heat shield and to maximize the distance to vinyl clad soffits.

\*\*\* The periscope requires a minimum 18 inches clearance from an inside corner.

\*\*\*\* This is a recommended distance. For additional requirements, check local codes.

† 3 feet above if within 10 feet horizontally.

‡ A vent shall not terminate where it may cause hazardous frost or ice accumulations on adjacent property surfaces.

†† Permitted only if the veranda, porch, or deck is fully open on a minimum of two sides beneath the floor.

†\* Recommended to prevent recirculation of exhaust products. For additional requirements, check local codes.

††\* Permitted only if the balcony is fully open on a minimum of one side.

**note:**

Clearances are to be in accordance with local installation codes and the requirements of the gas supplier. In their absence, clearances are to be as listed above and are based on national codes.

# venting requirements

## 2.4 venting application flow chart

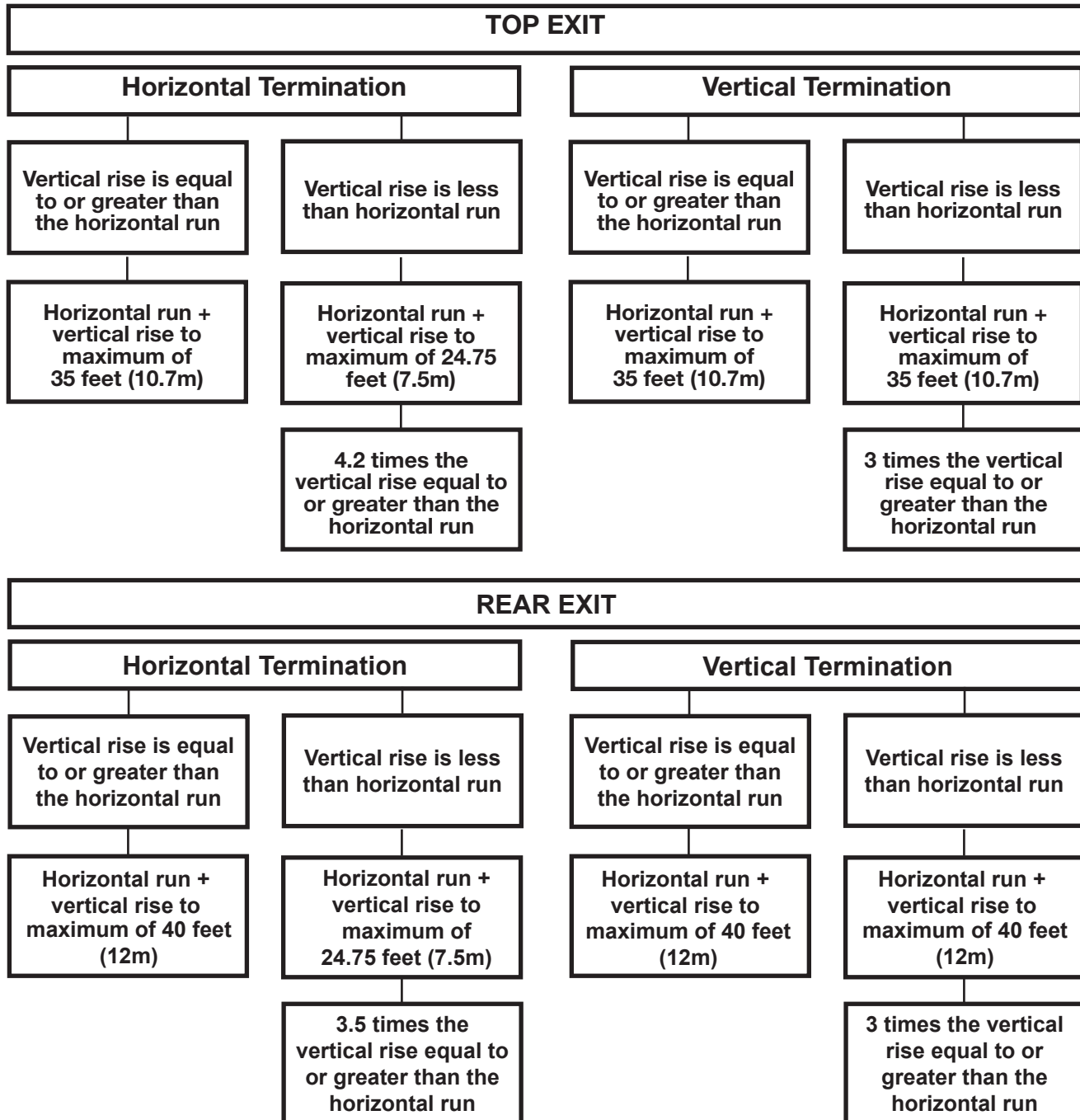

## 2.5 definitions

For the following symbols used in the venting calculations and examples are:

> - greater than

≥ - equal to or greater than

< - less than

≤ - equal to or less than

$H_T$  - total of both horizontal vent lengths ( $H_r$ ) and offsets ( $H_o$ ) in feet

$H_R$  - combined horizontal vent lengths in feet

$H_O$  - offset factor: .03 (total degrees of offset - 90°) in feet

$V_T$  - combined vertical vent lengths in feet

## 2.6 elbow vent length values

	<b>FEET</b>	<b>INCHES</b>	<b>MILLIMETERS</b>
1°	0.03	0.5	12.7
15°	0.45	6.0	152.4
30°	0.9	11.0	279.4
45°	1.35	16.0	406.4
90°*	2.7	32.0	812.8

\* The first 90° offset has a zero value and is shown in the formula as - 90°

## 2.7 top exit horizontal termination

$$(H_T) \leq (V_T)$$

Simple venting configuration (only one 90° elbow)

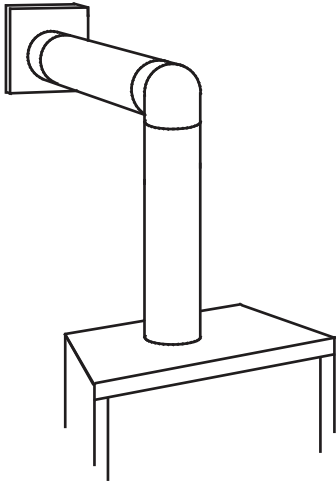

See graph to determine the required vertical rise  $V_T$  for the required horizontal run  $H_T$ .

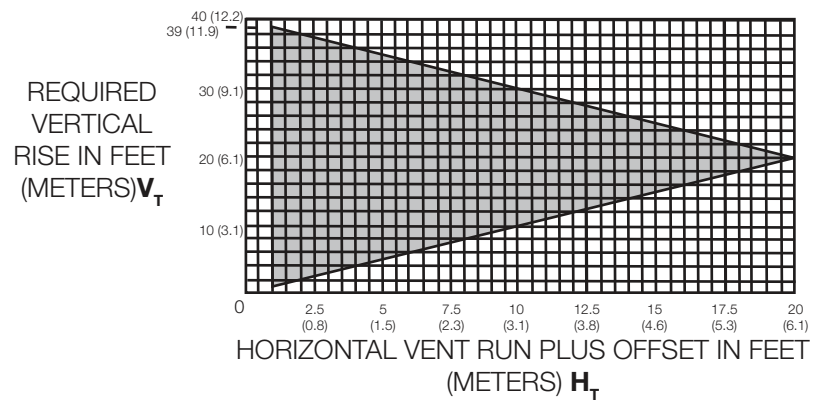

The shaded area within the lines represents acceptable values for  $H_T$  and  $V_T$

For vent configurations requiring more than one 90° elbow, the following formulas apply:

**Formula 1:**  $H_T \leq V_T$

**Formula 2:**  $H_T + V_T \leq 40$  feet (12.2m)

**Example:**

$V_1 = 3$  FT (0.9m)

$V_2 = 8$  FT (2.4m)

$V_T = V_1 + V_2 = 3$  FT (0.9m) + 8 FT (2.4m) = 11 FT (3.4m)

$H_1 = 2.5$  FT (0.8m)

$H_2 = 2$  FT (0.6m)

$H_R = H_1 + H_2 = 2.5$  FT (0.8m) + 2 FT (0.6m) = 4.5 FT (1.4m)

$H_O = .03$  (three 90° elbows - 90°) = .03 (270° - 90°) = 5.4 FT (1.7m)

$H_T = H_R + H_O = 4.5$  FT (1.4m) + 5.4 FT (1.6m) = 9.9 FT (3m)

$H_T + V_T = 9.9$  FT (3m) + 11 FT (3.4m) = 20.9 FT (6.4m)

**Formula 1:**  $H_T \leq V_T$   
 $9.9$  FT (3m)  $\leq$  11 FT (3.4m)

**Formula 2:**  $H_T + V_T \leq 40$  FT (12.2m)  
 $20.9$  FT (6.4m)  $\leq$  40 FT (12.2m)

Since both formulas are met, this vent configuration is acceptable.

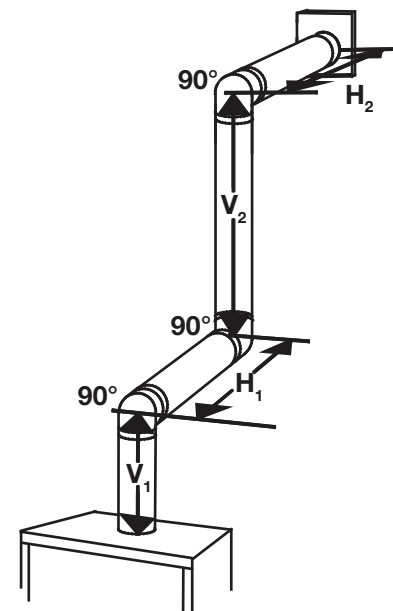

# venting requirements

$(H_T) > (V_T)$

Simple venting configuration  
(only one 90° elbow)

See graph to determine the required vertical rise  $V_T$  for the required horizontal run  $H_T$ .

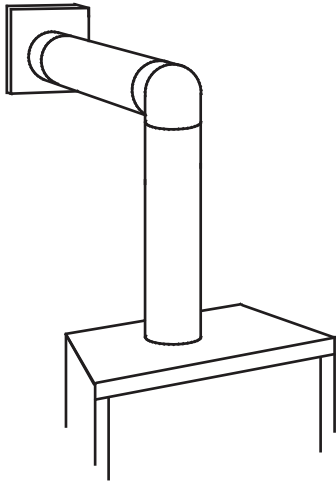

REQUIRED VERTICAL RISE IN INCHES (CENTIMETERS)  $V_T$

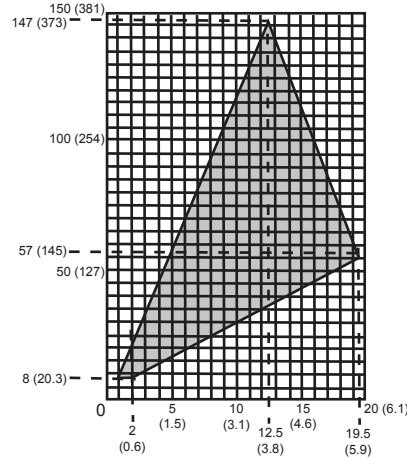

HORIZONTAL VENT RUN PLUS OFFSET IN FEET (METERS)  $H_T$   
The shaded area within the lines represents acceptable values for  $H_T$  and  $V_T$

For vent configurations requiring more than one 90° elbow, the following formulas apply:

Formula 1:  $H_T \leq 4.2 V_T$

Formula 2:  $H_T + V_T \leq 24.75 \text{ feet (7.5m)}$

Example:

$V_1 = V_T = 6 \text{ FT (1.8m)}$

$H_1 = 3 \text{ FT (0.9m)}$

$H_2 = 5 \text{ FT (1.5m)}$

$H_R = H_1 + H_2 = 3 \text{ FT (0.9m)} + 5 \text{ FT (1.5m)} = 8 \text{ FT (2.4m)}$

$H_O = .03 \text{ (two } 90^\circ \text{ elbows - } 90^\circ) = .03 \text{ (} 180^\circ - 90^\circ) = 2.7 \text{ FT (0.8m)}$

$H_T = H_R + H_O = 8 \text{ FT (2.4m)} + 2.7 \text{ FT (0.8m)} = 10.7 \text{ FT (3.3m)}$

$H_T + V_T = 10.7 \text{ FT (3.3m)} + 6 \text{ FT (1.8m)} = 16.7 \text{ FT (5.1m)}$

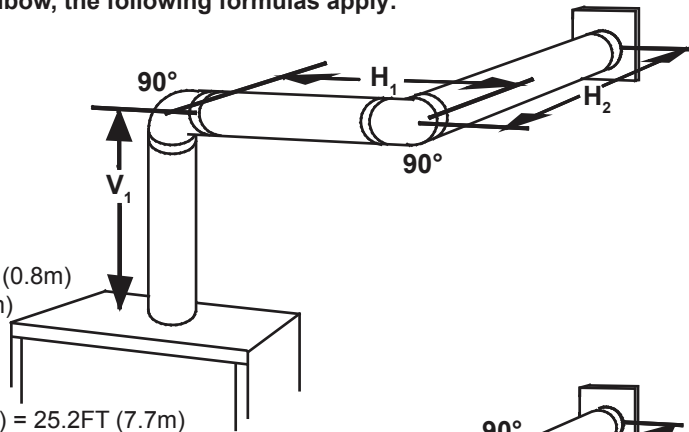

Formula 1:  $H_T \leq 4.2 V_T$   
 $4.2 V_T = 4.2 \text{ FT (1.3m)} \times 6 \text{ FT (1.8m)} = 25.2 \text{ FT (7.7m)}$

Formula 2:  $H_T + V_T \leq 24.75 \text{ FT (7.5m)}$   
 $16.7 \text{ FT (5.1m)} \leq 24.75 \text{ FT (7.5m)}$

Since both formulas are met, this vent configuration is acceptable.

Example:

$V_1 = 4 \text{ FT (1.2m)}$

$V_2 = 1.5 \text{ FT (0.5m)}$

$V_T = V_1 + V_2 = 4 \text{ FT (1.2m)} + 1.5 \text{ FT (0.5m)} = 5.5 \text{ FT (1.7m)}$

$H_1 = 2 \text{ FT (0.6m)}$

$H_2 = 1 \text{ FT (0.3m)}$

$H_3 = 1 \text{ FT (0.3m)}$

$H_4 = 1.5 \text{ FT (0.5m)}$

$H_R = H_1 + H_2 + H_3 + H_4 = 2 \text{ FT (0.6m)} + 1 \text{ FT (0.3m)} + 1 \text{ FT (0.3m)} + 1.5 \text{ FT (0.5m)} = 5.5 \text{ FT (1.7m)}$

$H_O = .03 \text{ (four } 90^\circ \text{ elbows - } 90^\circ) = .03 \text{ (} 360^\circ - 90^\circ) = 8.1 \text{ FT (2.5m)}$

$H_T = H_R + H_O = 5.5 \text{ FT (1.7m)} + 8.1 \text{ FT (2.5m)} = 13.6 \text{ FT (4.2m)}$

$H_T + V_T = 13.6 \text{ FT (4.2m)} + 5.5 \text{ FT (1.7m)} = 19.1 \text{ FT (5.8m)}$

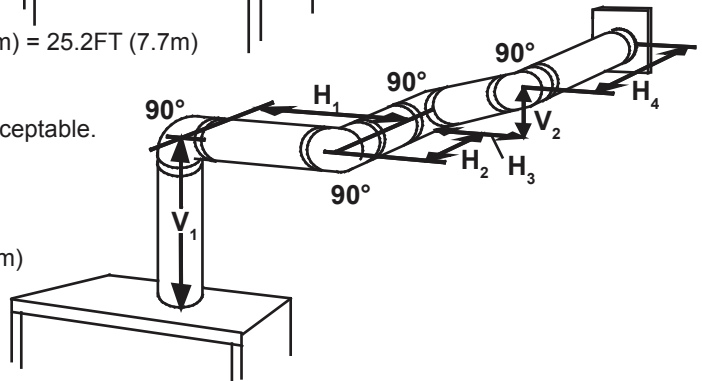

Formula 1:  $H_T \leq 4.2 V_T$   
 $4.2 V_T = 4.2 \text{ FT (1.3m)} \times 5.5 \text{ FT (1.7m)} = 23.1 \text{ FT (7m)}$   
 $13.6 \text{ FT (4.2m)} \leq 23.1 \text{ FT (7m)}$

Formula 2:  $H_T + V_T \leq 24.75 \text{ FT (7.5m)}$   
 $19.1 \text{ FT (5.8m)} \leq 24.75 \text{ FT (7.5m)}$

Since both formulas are met, this vent configuration is acceptable.

2.8 rear exit horizontal termination

$(H_T) \leq (V_T)$

Simple venting configuration  
(only two 90° elbows)

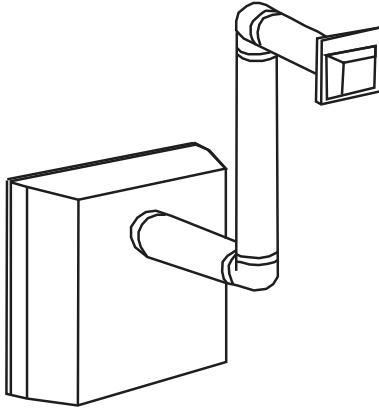

See graph to determine the required vertical rise  $V_T$  for the required horizontal run  $H_T$ .

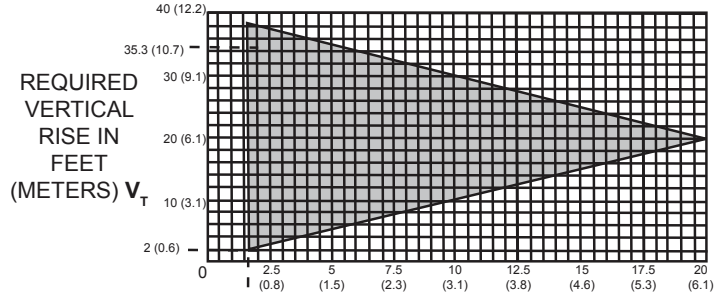

HORIZONTAL VENT RUN PLUS OFFSET IN FEET (METERS)  $H_T$   
The shaded area within the lines represents acceptable values for  $H_T$  and  $V_T$

For vent configurations requiring more than two 90° elbows, the following formulas apply:

Formula 1:  $H_T \leq V_T$

Formula 2:  $H_T + V_T \leq 40 \text{ feet (12.2m)}$

Example:

$V_1 = 9 \text{ FT (2.7m)}$

$V_2 = 6 \text{ FT (1.8m)}$

$V_T = V_1 + V_2 = 9\text{FT (2.7m)} + 6\text{FT (1.8m)} = 15\text{FT (4.6m)}$

$H_1 = 3 \text{ FT (0.9m)}$

$H_2 = 2 \text{ FT (0.6m)}$

$H_3 = 1.5 \text{ FT (0.5m)}$

$H_R = H_1 + H_2 + H_3 = 3\text{FT (0.9m)} + 2\text{FT (0.6m)} + 1.5\text{FT (0.5m)} = 6.5\text{FT (2m)}$

$H_o = .03 (\text{four } 90^\circ \text{ elbows} - 90^\circ) = .03 (360^\circ - 90^\circ) = 8.1 \text{ FT (2.5m)}$

$H_T = H_R + H_o = 6.5\text{FT (2m)} + 8.1\text{FT (2.5m)} = 14.6\text{FT (4.5m)}$

$H_T + V_T = 14.6\text{FT (4.5m)} + 15\text{FT (4.6m)} = 29.6 \text{ FT (9m)}$

Formula 1:  $H_T \leq V_T$   
 $14.6 \text{ FT (4.5m)} \leq 15 \text{ FT (4.6m)}$

Formula 2:  $H_T + V_T \leq 40 \text{ FT (12.2m)}$   
 $29.6 \text{ FT (9m)} \leq 40 \text{ FT (12.2m)}$

Since both formulas are met, this vent configuration is acceptable.

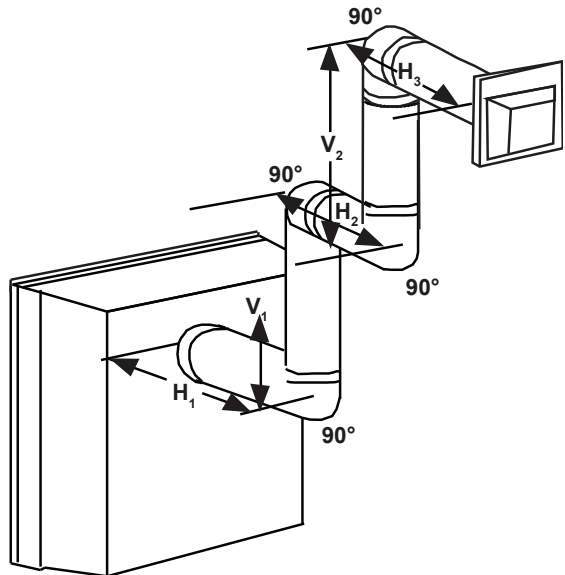



$$(H_T) > (V_T)$$

**Simple venting configuration**  
(only two 90° elbows)

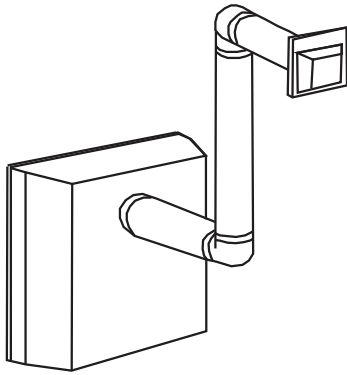

See graph to determine the required vertical rise  $V_T$  for the required horizontal run  $H_T$ .

REQUIRED  
VERTICAL RISE IN  
FEET  
(METERS)  $V_T$

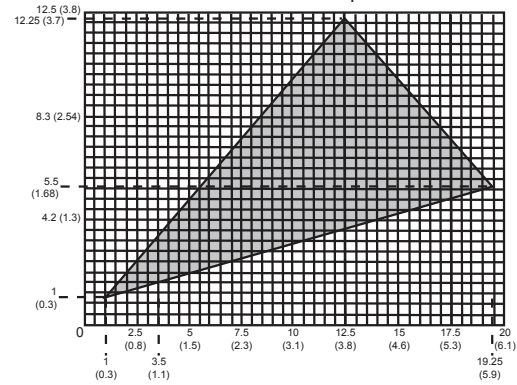

HORIZONTAL VENT RUN PLUS OFFSET IN FEET (METERS)  $H_T$   
The shaded area within the lines represents acceptable values for  $H_T$  and  $V_T$ .

For vent configurations requiring more than two 90° elbows, the following formulas apply:

**Formula 1:**  $H_T \leq 3.5V_T$

**Formula 2:**  $H_T + V_T \leq 24.75$  feet (7.5m)

**Example:**

$V_1 = 4$  FT (1.2m)

$V_2 = 1.5$  FT (0.5m)

$V_T = V_1 + V_2 = 4$  FT (1.2m) + 1.5 FT (0.5m) = 5.5 FT (1.7m)

$H_1 = 2$  FT (0.6m)

$H_2 = 1$  FT (0.3m)

$H_3 = 1$  FT (0.3m)

$H_4 = 1.5$  FT (0.5m)

$H_R = H_1 + H_2 + H_3 + H_4 = 2$  FT (0.6m) + 1 FT (0.3m) + 1 FT (0.3m) + 1.5 FT (0.5m) = 5.5 FT (1.7m)

$H_O = .03$  (four 90° elbows + one 45° elbow - 90°)

$= .03$  (90 + 90 + 90 + 90 + 45 - 90) = 9.45 FT (2.9m)

$H_T = H_R + H_O = 5.5$  FT (1.7m) + 9.45 FT (2.9m) = 14.95 FT (4.6m)

$H_T + V_T = 14.95$  FT (4.6m) + 5.5 FT (1.7m) = 20.45 FT (6.2m)

**Formula 1:**  $H_T \leq 3.5V_T$   
 $3.5V_T = 3.5$  FT (1.1m) x 5.5 FT (1.7m) = 19.25 FT (5.9m)  
 $14.95$  FT (4.6m)  $\leq$  19.25 FT (5.9m)

**Formula 2:**  $H_T + V_T \leq 24.75$  FT (7.5m)  
 $20.45$  FT (6.2m)  $\leq$  24.75 FT (7.5m)

Since both formulas are met, this vent configuration is acceptable.

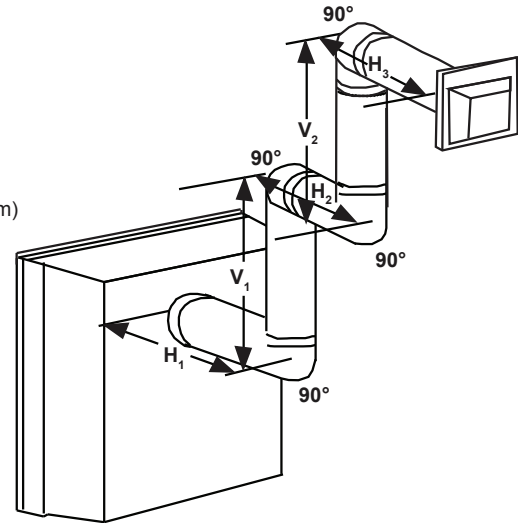

2.9 top and rear exit vertical termination

$(H_T) \leq (V_T)$

Simple venting configurations.

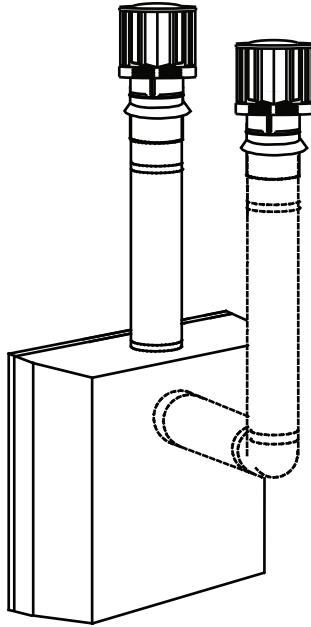

See graph to determine the required vertical rise  $V_T$  for the required horizontal run  $H_T$ .

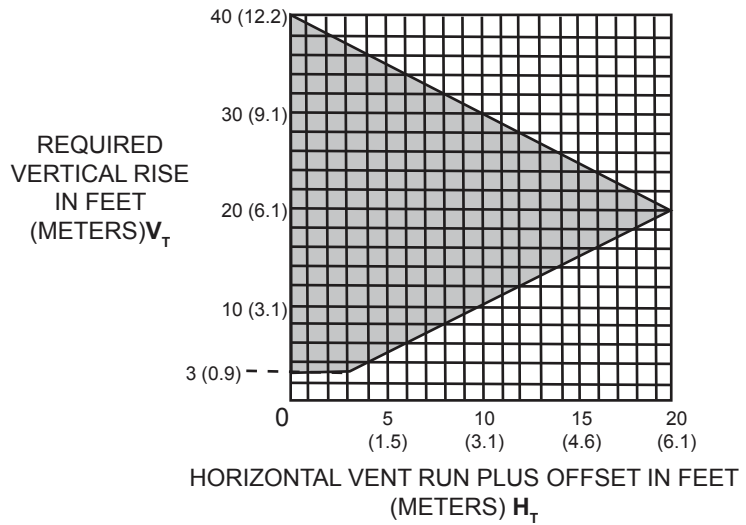

The shaded area within the lines represents acceptable values for  $H_T$  and  $V_T$

For vent configurations requiring one or more 90° elbows (top exit) or one or more 90° elbows (rear exit), the following formulas apply:

Formula 1:  $H_T \leq V_T$

Formula 2:  $H_T + V_T \leq 40$  feet (12.2m)

Example:

$V_1 = 5$  FT (1.5m)

$V_2 = 6$  FT (1.8m)

$V_3 = 10$  FT (3.1m)

$V_T = V_1 + V_2 + V_3 = 5$  FT (1.5m) + 6 FT (1.8m) + 10 FT (3.1m) = 21 FT (6.4m)

$H_1 = 8$  FT (2.4m)

$H_2 = 2.5$  FT (0.8m)

$H_R = H_1 + H_2 = 8$  FT (2.4m) + 2.5 FT (0.8m) = 10.5 FT (3.2m)

$H_o = .03$  (four 90° elbows - 90°)

$= .03$  (360° - 90°) = 8.1 FT (2.5m)

$H_T = H_R + H_o = 10.5$  FT (3.2m) + 8.1 FT (2.5m) = 18.6 FT (5.7m)

$H_T + V_T = 18.6$  FT (5.7m) + 21 FT (6.4m) = 39.6 FT (12.1m)

Formula 1:  $H_T \leq 3.5V_T$   
 $18.6$  FT (5.7m)  $\leq 21$  FT (6.4m)

Formula 2:  $H_T + V_T \leq 40$  FT (12.2m)  
 $39.6$  FT (12.1m)  $\leq 40$  FT (12.2m)

Since both formulas are met, this vent configuration is acceptable.

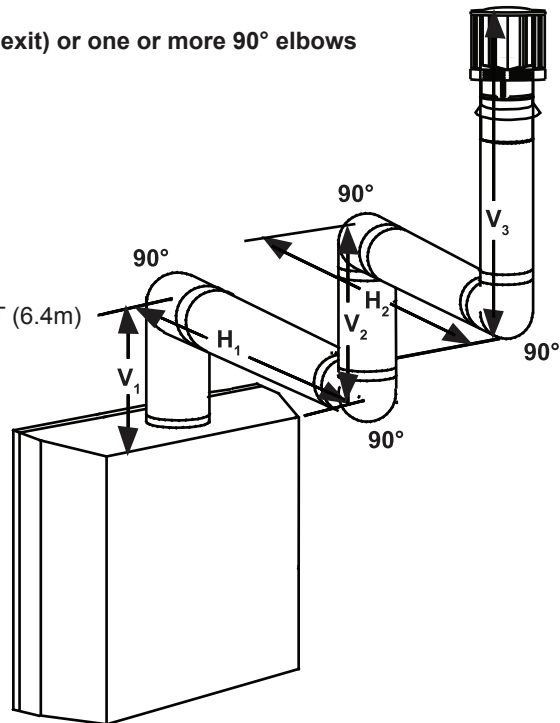

$$(H_T) > (V_T)$$

Simple venting configurations.

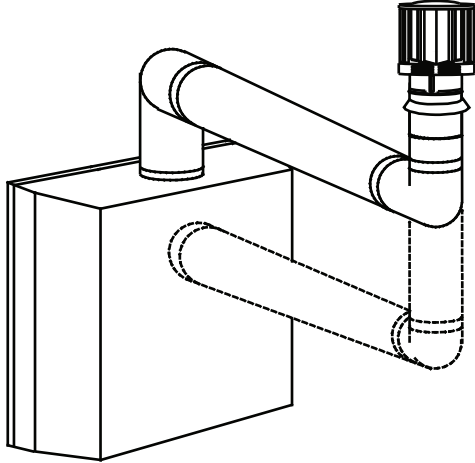

See graph to determine the required vertical rise  $V_T$  for the required horizontal run  $H_T$ .

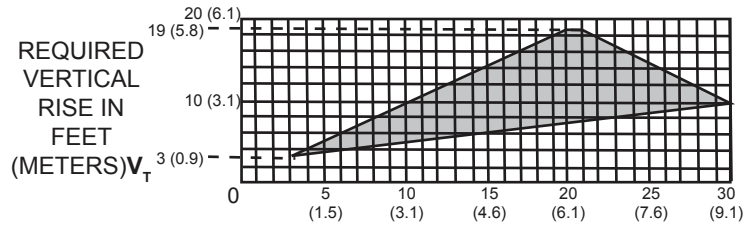

HORIZONTAL VENT RUN PLUS OFFSET IN FEET (METERS)  $H_T$

The shaded area within the lines represents acceptable values for  $H_T$  and  $V_T$

For vent configurations requiring more than two 90° elbows (top exit) or one 90° elbow (rear exit), the following formulas apply:

**Formula 1:**  $H_T \leq 3 V_T$

**Formula 2:**  $H_T + V_T \leq 40 \text{ feet (12.2m)}$

**Example:**

$V_1 = 2 \text{ FT (0.6m)}$

$V_2 = 1 \text{ FT (0.3m)}$

$V_3 = 1.5 \text{ FT (0.5m)}$

$V_T = V_1 + V_2 + V_3 = 2\text{FT (0.6m)} + 1\text{FT (0.3m)} + 1.5\text{FT (0.5m)} = 4.5 \text{ FT (1.4m)}$

$H_1 = 6 \text{ FT (1.8m)}$

$H_2 = 2 \text{ FT (0.6m)}$

$H_R = H_1 + H_2 = 6\text{FT (1.8m)} + 2\text{FT (0.6m)} = 8 \text{ FT (2.4m)}$

$H_o = .03 \text{ (four } 90^\circ \text{ elbows} - 90^\circ)$

$= .03 \text{ (} 360^\circ - 90^\circ) = 8.1 \text{ FT (2.5m)}$

$H_T = H_R + H_o = 8\text{FT (2.4m)} + 8.1\text{FT (2.5m)} = 16.1\text{FT (4.9m)}$

$H_T + V_T = 16.1\text{FT (4.9m)} + 4.5\text{FT (1.4m)} = 20.6\text{FT (6.3m)}$

**Formula 1:**  $H_T \leq 3.5 V_T$

$3.5 V_T = 3(0.9\text{m}) \times 4.5\text{FT (1.4m)} = 13.5 \text{ FT (4.1m)}$

$16.1\text{FT (4.9m)} \leq 13.5 \text{ FT (4.1m)}$

Since this formula is not met, this vent configuration is **unacceptable**.

**Formula 2:**  $H_T + V_T \leq 40 \text{ FT (12.2m)}$

$16.1\text{FT (4.9m)} \leq 13.5 \text{ (4.1m)}$

Since only formula 2 is met, this vent configuration is unacceptable and a new fireplace location or vent configuration will need to be established to satisfy both formulas.

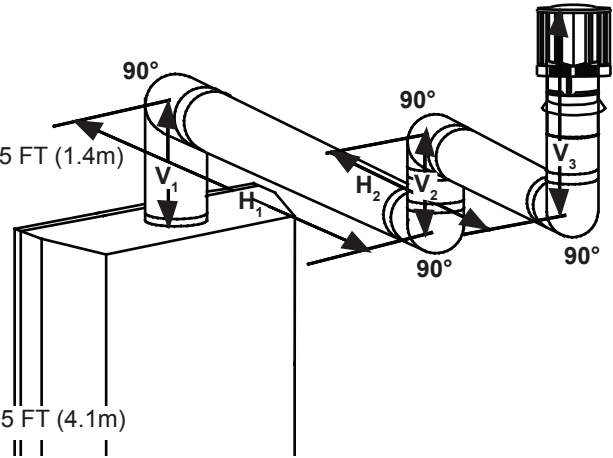

Example:

$$V_1 = 1.5 \text{ FT (0.5m)}$$

$$V_2 = 5 \text{ FT (1.5m)}$$

$$V_T = V_1 + V_2 = 1.5\text{FT (0.5m)} + 5\text{FT (1.5m)} = 6.5 \text{ FT (2m)}$$

$$H_1 = 1 \text{ FT (0.3m)}$$

$$H_2 = 1 \text{ FT (0.3m)}$$

$$H_3 = 10.75 \text{ FT (3.3m)}$$

$$H_R = H_1 + H_2 + H_3 = 1\text{FT (0.3m)} + 1\text{FT (0.3m)} + 10.75\text{FT (3.3m)} = 12.75\text{FT (3.9m)}$$

$$H_O = .03 \text{ (three } 90^\circ \text{ elbows + one } 45^\circ \text{ elbow - } 90^\circ)$$

$$= .03 (270^\circ + 45^\circ - 90^\circ) = 6.75 \text{ FT (2.1m)}$$

$$H_T = H_R + H_O = 12.75\text{FT (3.9m)} + 6.75\text{FT (2.1m)} = 19.5 \text{ FT (5.9m)}$$

$$H_T + V_T = 19.5\text{FT (5.9m)} + 6.5\text{FT (2m)} = 26 \text{ FT (7.9m)}$$

Formula 1:

$$H_T \leq 3 V_T$$

$$3 V_T = 3\text{FT (0.9m)} \times 6.5\text{FT (2m)} = 19.5\text{FT (5.9m)}$$

$$19.5\text{FT (5.9m)} = 19.5\text{FT (5.9m)}$$

Formula 2:

$$H_T + V_T \leq 40 \text{ FT (12.2m)}$$

$$26 \text{ FT (7.9m)} \leq 40 \text{ FT (12.2m)}$$

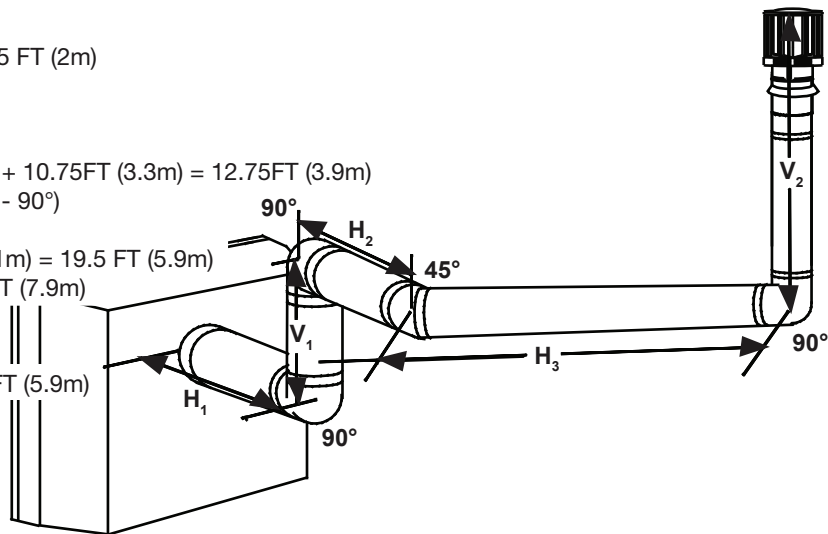

Since both formulas are met, this vent configuration is acceptable.

## 2.10 rear exit

### ! WARNING

- Failure to create a seal to the firebox with the exhaust collar assembly will cause the appliance to function improperly and can cause injury or property damage.

- Remove the safety barrier and glass front, refer to "safety barrier & door removal/installation" section.
- Remove the contents from the firebox and set aside, you will need the exhaust flue collar from the top of the log carton.
- To ease assembly, remove the four hex head screws securing the deflector from inside the top front of the firebox, refer to Figure 1. Set deflector aside.
- Place the gasket (provided) over the 4" (102mm) flue collar assembly and bend along perforation.
- From inside the firebox, insert the 4" (102mm) flue collar through the back of the firebox. Install the rear exit shield onto the 4" (102mm) flue collar, see "rear exit shield" section for installation instructions.
- Secure the flue collar assembly, gasket and rear exit shield using the four hex head 3/8" thread cutting screws, refer to Figure 2.

Fig. 1

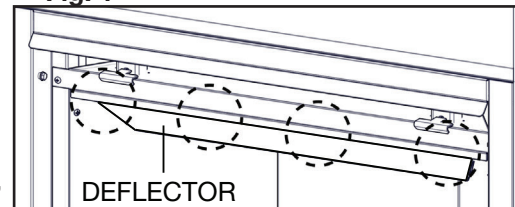

Fig. 2



**note:**

Do not overtighten. The gasket needs only to be snug against the firebox.

- Reattach the deflector using the four screws and install the log set, glass door and safety barrier.
- Remove the four screws securing the gasket and the outer coverplate. Install the 7" collar assembly, complete with gasket, onto the rear panel around the 4" collar (Fig. 3).
- Secure the gasket (provided in manual baggie) and the outer cover plate over the top opening of the appliance.

Fig. 3

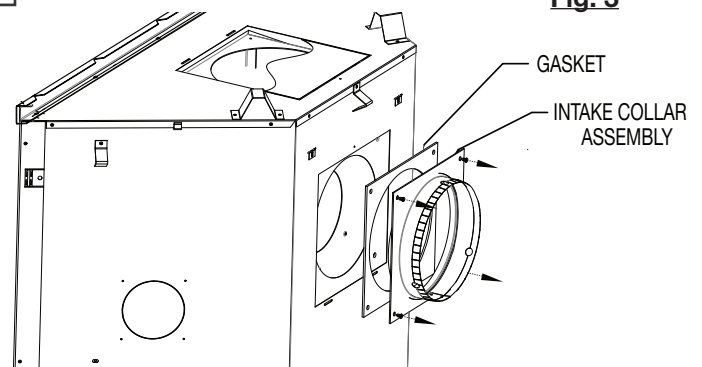

## venting requirements

### 2.11 rear exit shield (for rear vent only)

- A.** Remove the safety barrier assembly and door from the appliance, refer to the “safety barrier & door removal / installation” section of the manual for detailed instructions.
- B.** Loosen the two screws, that secure the exhaust plate, and slide the shield in place by sliding its slotted openings behind the screwheads, tighten the two previously loosened screws. Refer to the illustration below.
- C.** Reinstall the door and safety barrier assembly on the appliance, refer to the “safety barrier & door removal / installation” section of the manual for detailed instructions.

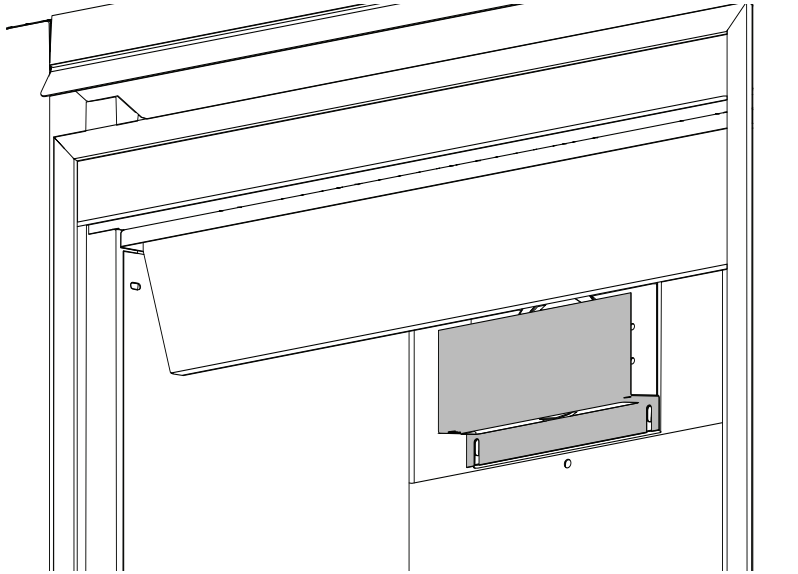
**note:**

This shield is used to block the view through the venting to the outdoors.



2.12 top exit

**! WARNING**

- Failure to install the cover plate and gasket will cause the appliance to function improperly and can cause injury or property damage.

**This appliance has been factory shipped as a top vent.**

- A. Remove the safety barrier and glass door (see "safety barrier & door removal/installation" section).
- B. Remove the contents from the firebox and set aside. You will need the exhaust and air inlet collar.
- C. To ease assembly, remove the 4 hex head screws, securing the deflector from inside the top front of the firebox (**Fig. 1**).

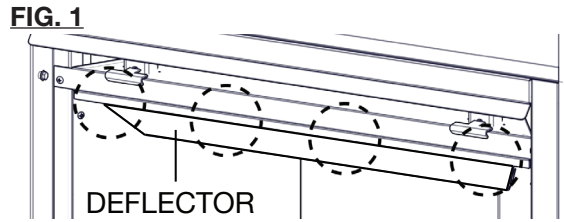

- D. Remove the 1 1/2" (38.1mm) thick batt of insulation and **discard** (**Fig. 2**).

- E. Place the 7" (177.8mm) intake collar and gasket onto the top of the appliance and secure using 4 screws (**Fig. 2**).

**TIP: The manual baggie supplies the gasket and screws (packaged in another separate baggie).**

- F. From inside the firebox, install the 4" (101.6mm) exhaust collar with gasket up through the top of the firebox, and secure with the the 4 hex head 3/4" black screws supplied in the manual baggie.

**note:**  
Do not overtighten. The gasket needs only to be snug against the firebox.

- G. Reinstall the top deflector, log set, glass door, and safety barrier.

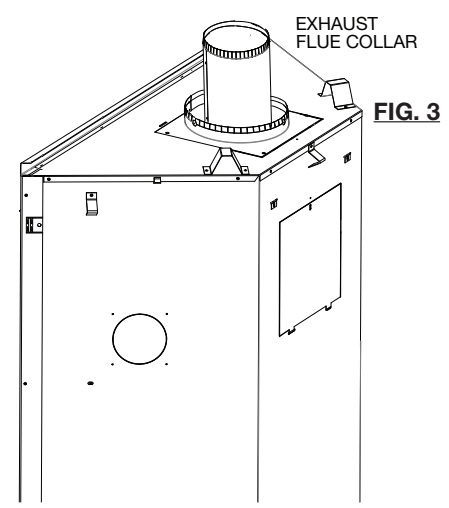
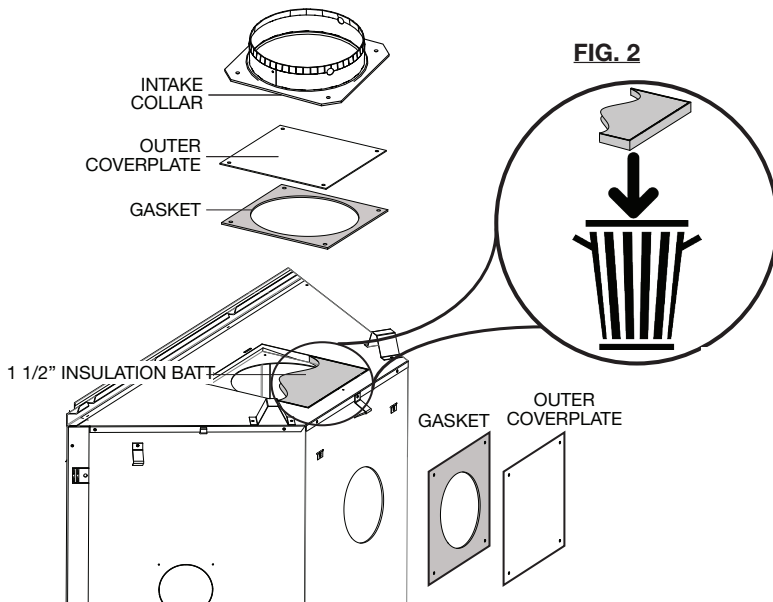

## 3.0 rough framing

**note:**

When using optional finishing accessories, the framing dimensions and finishing materials may differ from what is outlined in the section below; refer to the leaflet instructions supplied in the accessory kit for specific framing and finishing specifications.

### **WARNING**

- Risk of fire!
- In order to avoid the possibility of exposed insulation or vapour barrier coming in contact with the appliance body, it is recommended that the walls of the appliance enclosure be “finished” (i.e. drywall / sheetrock), as you would finish any other outside wall of a home. This will ensure that clearance to combustibles is maintained within the cavity.
- Do not notch the framing around the appliance stand offs. Failure to maintain air space clearance may cause over heating and fire. Prevent contact with sagging or loose insulation or framing and other combustible materials. Block opening into the chase to prevent entry of blown-in insulation. Make sure insulation and other materials are secured.
- When constructing the enclosure, allow for finishing material thickness to maintain clearances. Framing or finishing material closer than the minimums listed must be constructed entirely of non-combustible materials. Materials consisting entirely of steel, iron, brick, tile, concrete, slate, glass or plasters, or any combination thereof are suitable. Materials that are reported as passing ASTM E136, standard test method for behaviour of materials in a vertical tube furnace at 1382°F (750°C) and UL763 shall be considered non-combustible materials.
- Minimum clearance to combustibles must be maintained or a serious fire hazard could result.
- The appliance requires a minimum enclosure height. Measure from the appliance base.
- If steel stud framing kits with cement board are provided, or specified in the installation instructions, they must be installed.
- If specified in the installation instruction, finishing must be done using a non-combustible board, ceramic tile, marble, etc. Do **NOT** use wood or drywall. Any fire rated drywall is **not** acceptable.

### 3.1 minimum framing dimensions

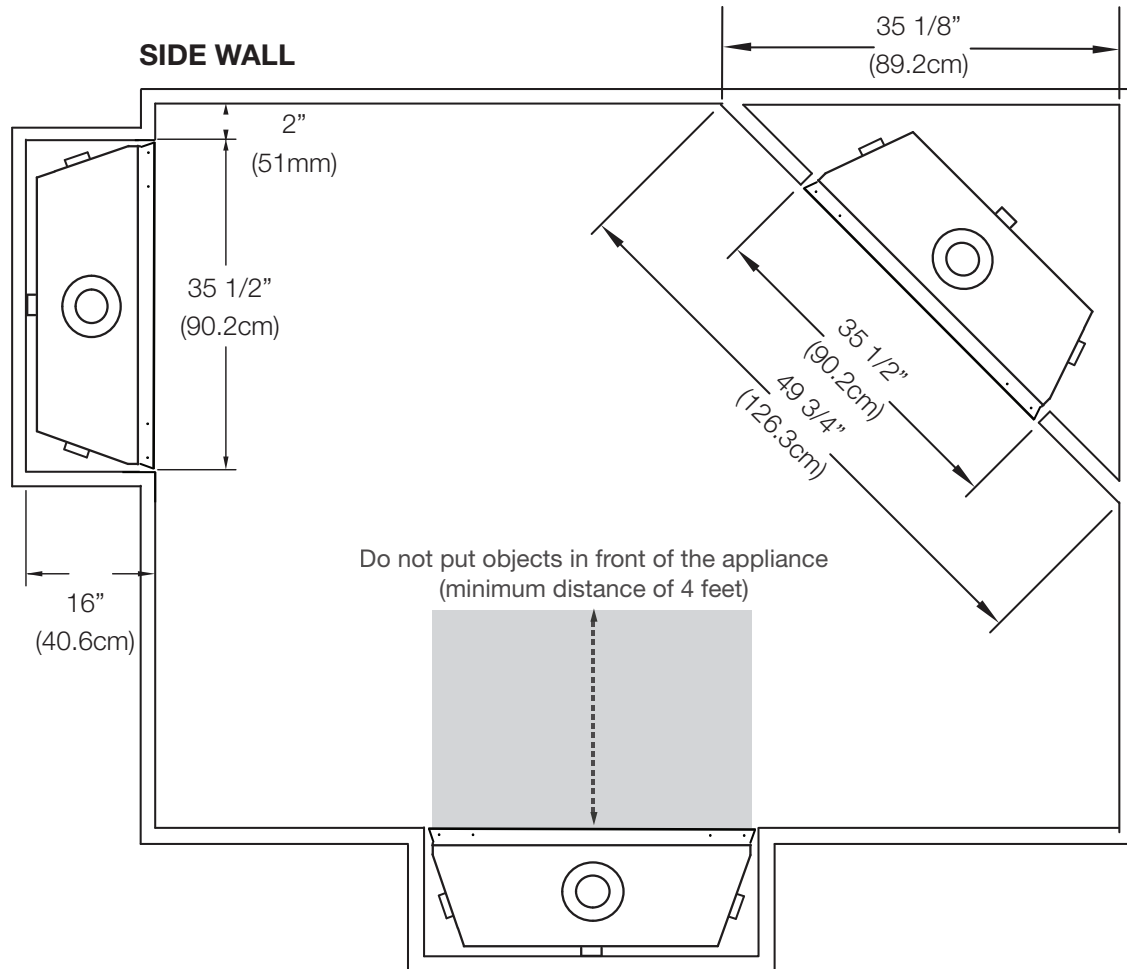

**HORIZONTAL VENT SECTIONS:** A minimum of 1" (25mm) at the bottom and sides, and 3" (76.2mm) at the top of the vent pipe on all horizontal runs to combustibles is required.

**NOTE:** The minimum clearances from the top of the horizontal vent pipe to combustible materials may be reduced from 3" (76.2mm) to 1" (25mm) in those installations with a minimum 38" (96.5cm) vertical vent rise made immediately off the appliance collar.

**VERTICAL VENT SECTIONS:** A minimum of 1" (25mm) all around the vent pipe on all vertical runs to combustibles is required except for clearances in appliance enclosures. Vertical runs within the enclosure must maintain a 3" (76.2mm) clearance from combustibles. See "minimum enclosure clearances" sections.

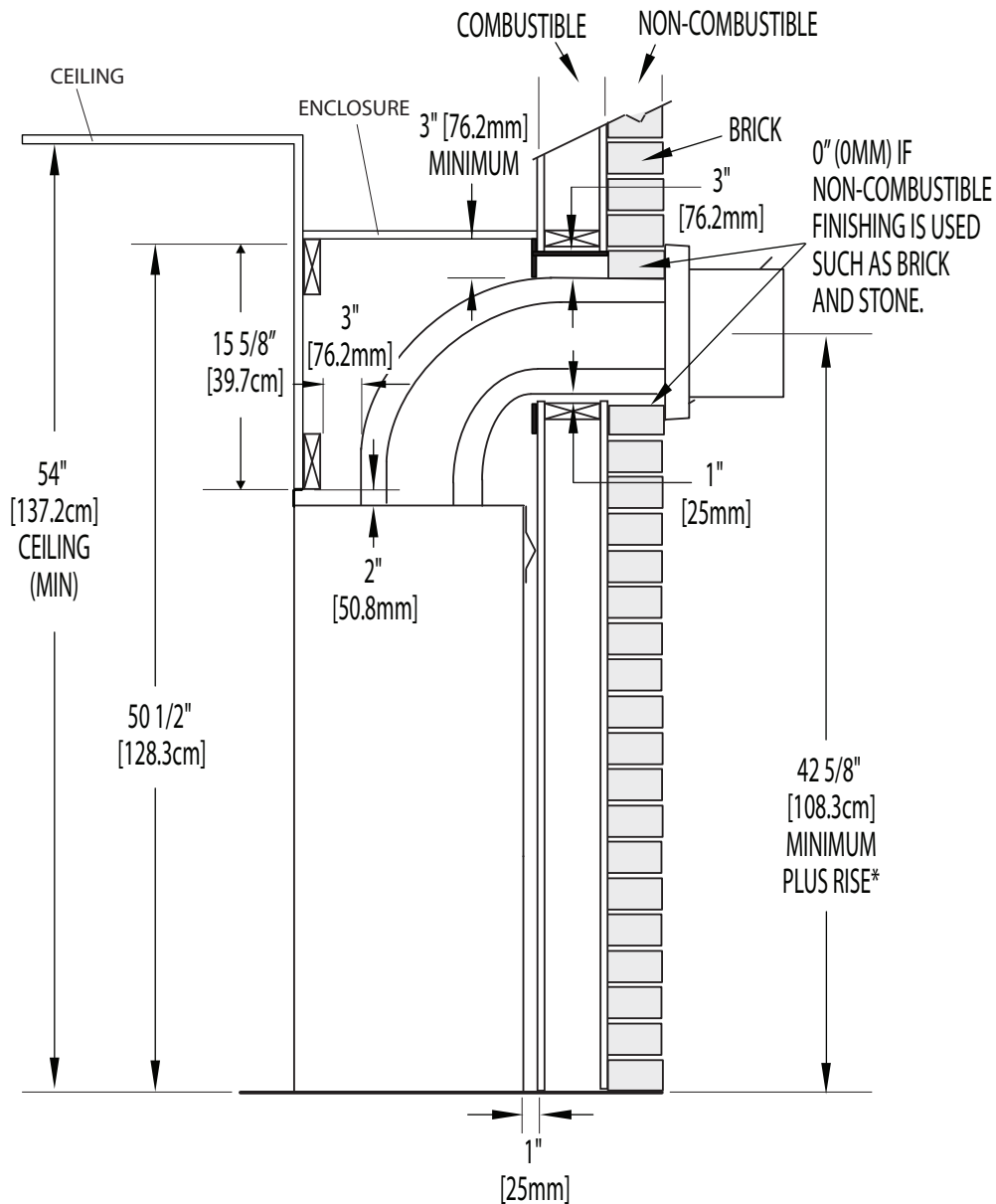
**TOP VENT****TOP EXIT ENCLOSURE**

The appliance requires a minimum enclosure height of 50 1/2" (128.3cm). For temperature requirements, the enclosure space around and above the appliance must be left unobstructed.

**NOTE: The vent shield is telescopic and must be adjusted to shield the full depth of the combustible wall penetration.**

\* See "minimum framing dimensions" section for details on reducing vent pipe top clearances.

These parameters also apply to all illustrations in this section.

**MINIMUM REAR VENT CLEARANCES**

**! WARNING**

- Universal Heat Management kit not available for rear vent installation.

For rear vent termination not exceeding 10" (254mm) of horizontal vent run.

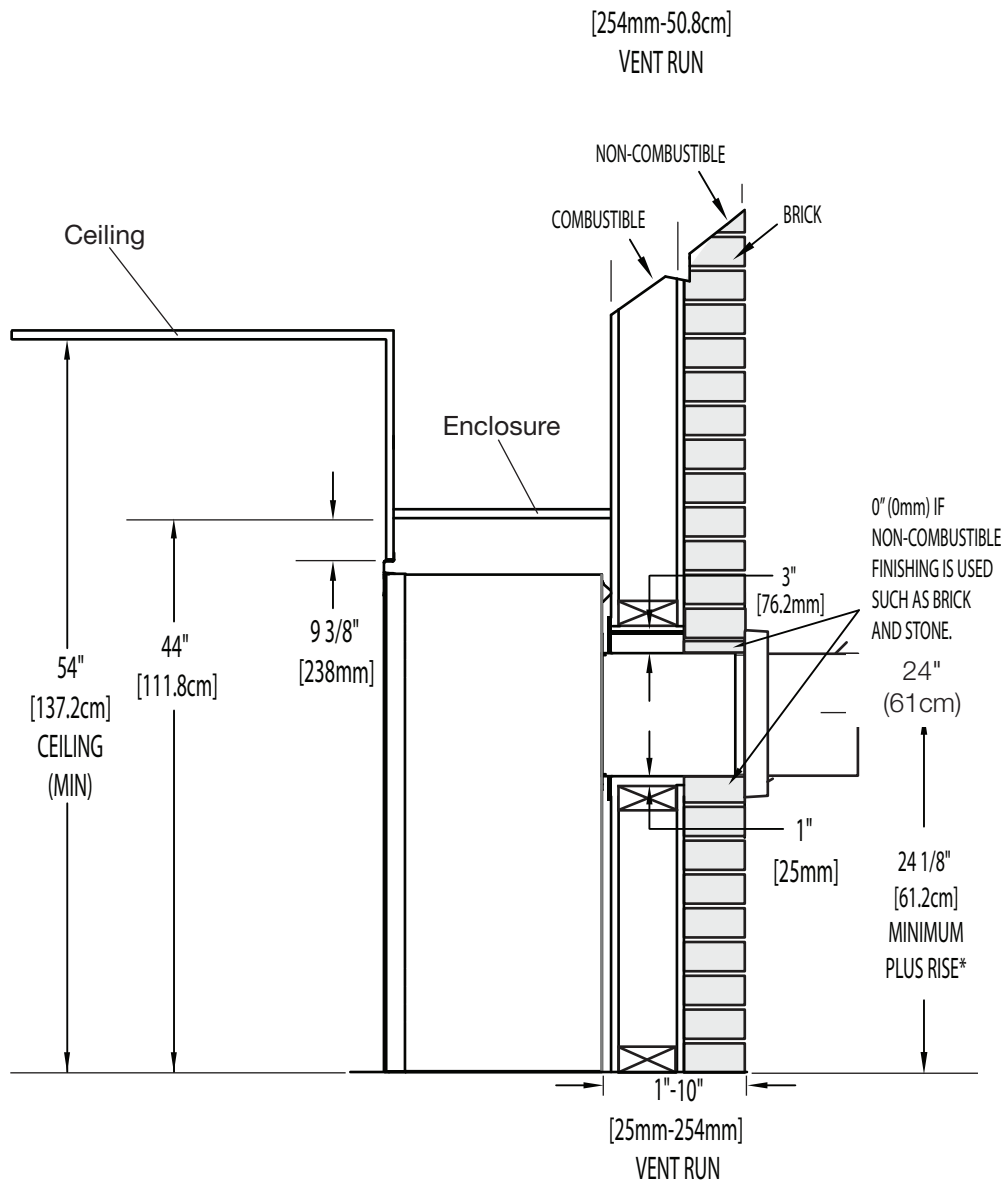

**REAR EXIT ENCLOSURE**

The appliance requires a minimum enclosure height of 44" (111.8cm). For temperature requirements, the enclosure space around and above the appliance must be left unobstructed.

**NOTE:** The vent shield is telescopic and must be adjusted to shield the full depth of the combustible wall penetration.

\* See "venting" section.

# rough framing

## MAXIMUM REAR VENT CLEARANCES

### (EXAMPLE 1: INTERIOR NICHE / BUMPOUT / ALCOVE)

#### ! WARNING

- Universal Heat Management kit not available for rear vent installation.

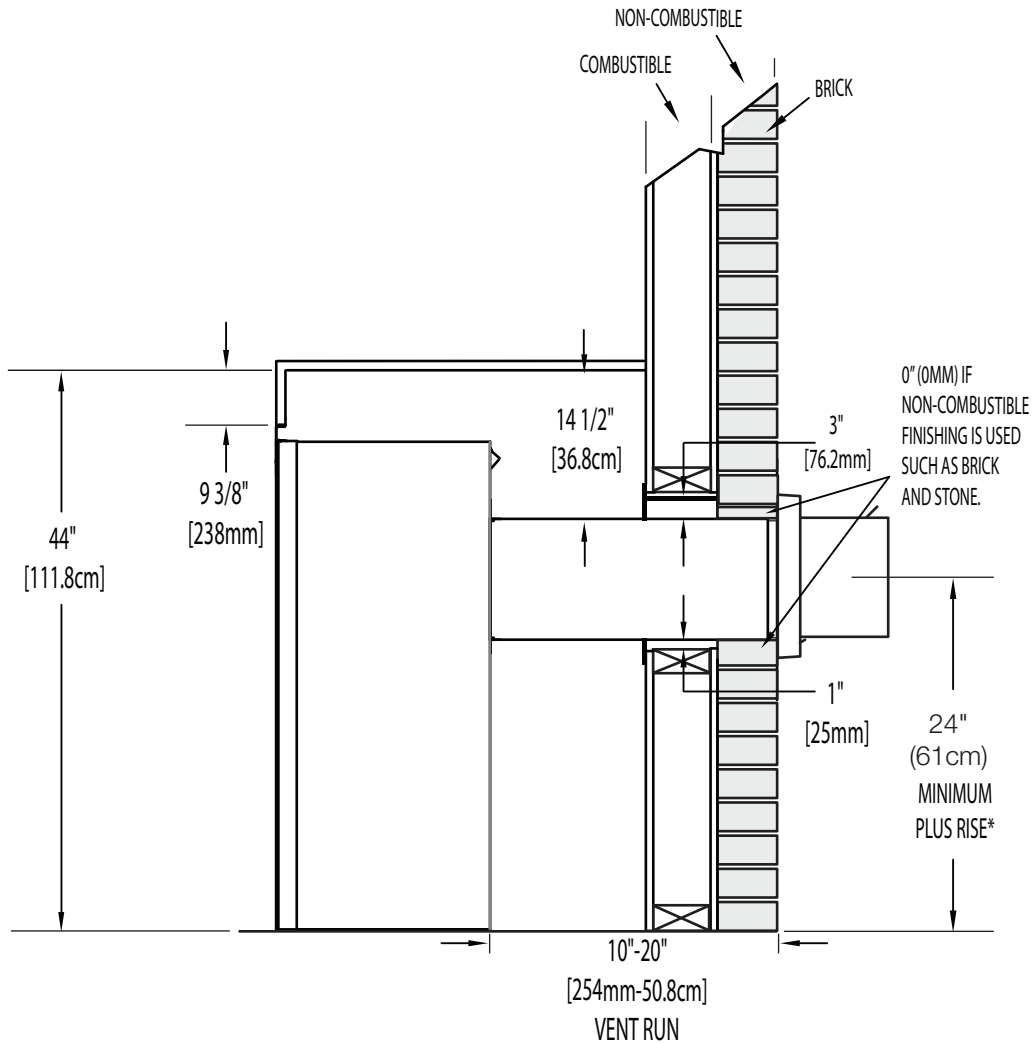

#### REAR EXIT ENCLOSURE

The appliance requires a minimum enclosure height of 44" (111.8cm). For temperature requirements, the enclosure space around and above the appliance must be left unobstructed.

**NOTE:** The vent shield is telescopic and must be adjusted to shield the full depth of the combustible wall penetration.

\* See "venting" section.

**MAXIMUM REAR VENT CLEARANCES**  
**(EXAMPLE 2: EXTERIOR ALCOVE / DOGHOUSE)**

**! WARNING**

- Universal Heat Management kit not available for rear vent installation.

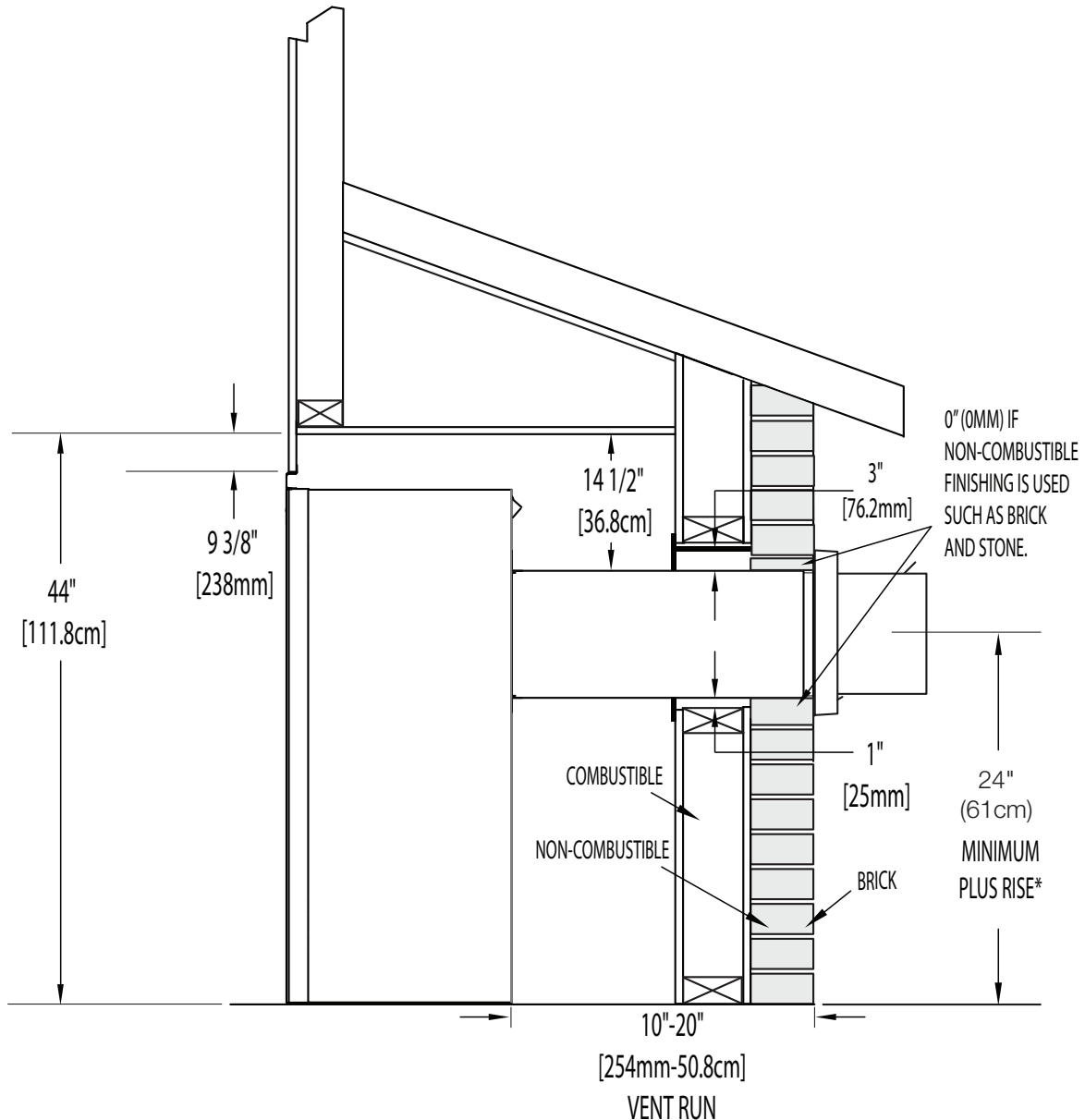

**REAR EXIT ENCLOSURE**

The appliance requires a minimum enclosure height of 44" (111.8cm). For temperature requirements, the enclosure space around and above the appliance must be left unobstructed.

**NOTE:** The vent shield is telescopic and must be adjusted to shield the full depth of the combustible wall penetration.

\* See "venting" section.

**note:**

For heavier finishing materials such as marble, we recommend adding extra support to the frame. Ensure there is adequate floor support for the appliance and finishing material.

Before framing your appliance, determine vent requirements before deciding the final location of the appliance. After rough framing, place the appliance in its final position.

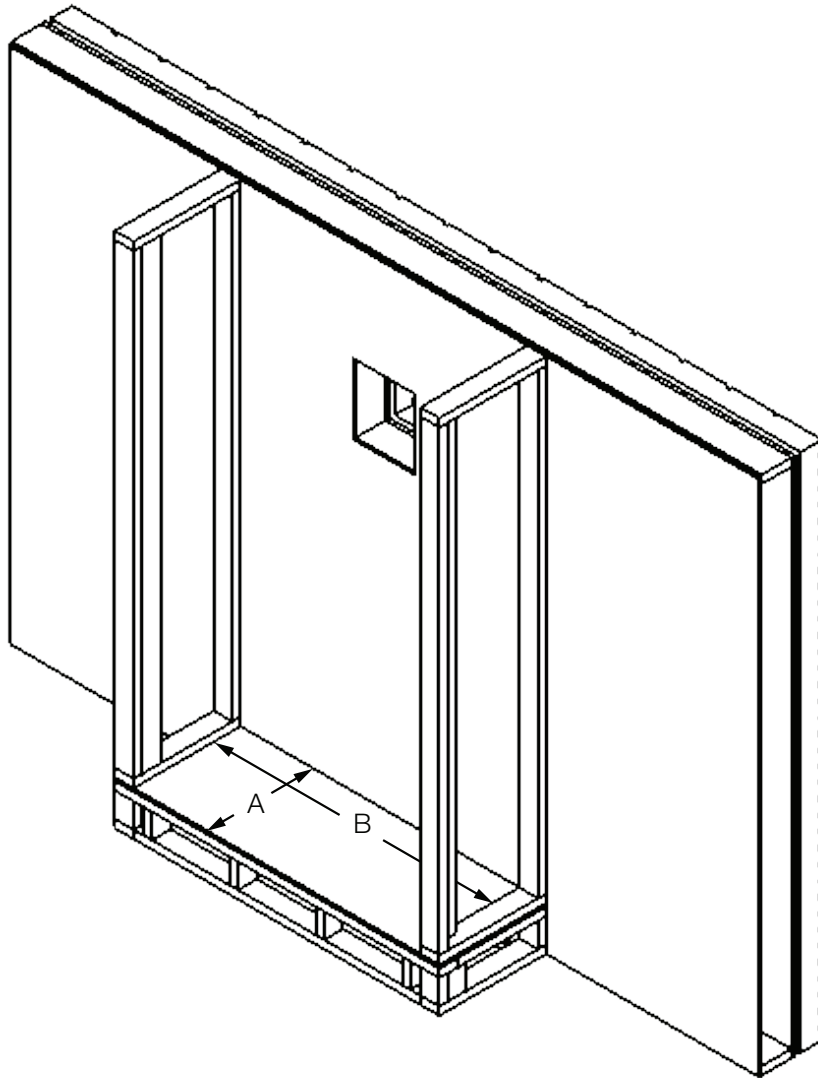

Ref	Minimum rough framing dimensions
A	16"* (40.6cm)
B	35 1/2" (90.2cm)

\* Based on 1/2" finishing material thickness.



 **WARNING**

- Ensure to unpack all loose materials from inside the firebox prior to connecting the gas and electrical supply
- **If your appliance is supplied with a remote, ensure the remote receiver is in the “OFF” position prior to connecting the gas and electrical supply to the appliance.**
- For safe and proper operation of the appliance, follow the venting instructions exactly.
- **The appliance exhaust flue collar must be sealed using Mill Pac.** All exhaust and intake vent pipe joints must be sealed using red RTV high temp silicone sealant (W573-0002) (not supplied) or black high temp Mill Pac (W573-0007) (not supplied).
- If using pipe clamps to connect rigid vent components, a minimum of 3 screws must also be used to ensure the connection cannot slip off.
- Do not clamp the flexible vent pipe.
- Risk of fire, explosion, or asphyxiation. Improper support of the entire venting system may allow vent to sag and separate. Use vent run supports and connect vent sections per installation instructions.
- Risk of fire, do not allow loose materials or insulation to touch the vent pipe. Remove insulation to allow for the installation of the attic shield and to maintain clearances to combustibles.
- Do not fill the space between the vent pipe and enclosure with any type of material. Do not pack insulation or combustibles between ceiling firestops. Always maintain specified clearances around venting and firestop systems. Install wall shields and firestops as specified. Failure to keep insulation or other materials away from vent pipe may cause fire.
- **For gas stoves only:** If the appliance is installed directly on carpeting, vinyl tile, or other combustible material other than wood flooring, the appliance shall be installed on a metal or wood panel extending the full width and depth, unless otherwise tested.

For safe and proper operation of the appliance, follow the venting instructions exactly.

# venting installation

## 4.1 horizontal installation

### ! WARNING

- The firestop assembly must be installed with the vent shield to the top.
- Terminals must not be recessed into a wall or siding more than the depth of the return flange of the mounting plate.
- The vent shield must be fixed in place by fastening the extended vent shield to the bend tabs using the supplied fasteners.

This application occurs when venting through an exterior wall. Having determined the correct height for the air terminal location, cut and frame a hole in the exterior wall, as illustrated, to accommodate the firestop assembly. Dry fit the firestop assembly before proceeding to ensure the brackets on the rear surface fit to the inside surface of the horizontal framing.

The vent shield must be installed to the full depth of the combustible wall. The length of the vent shield may cut shorter for combustible walls that less than 8 1/2" (216mm) thick.

#### note:

Bend the tabs for reduced side clearances or move the shield for reduced top clearances (dependent on specific appliance clearances). Do not fill the air space between the firestop spacer and the exterior wall with any type of insulating material (i.e. spray foam).

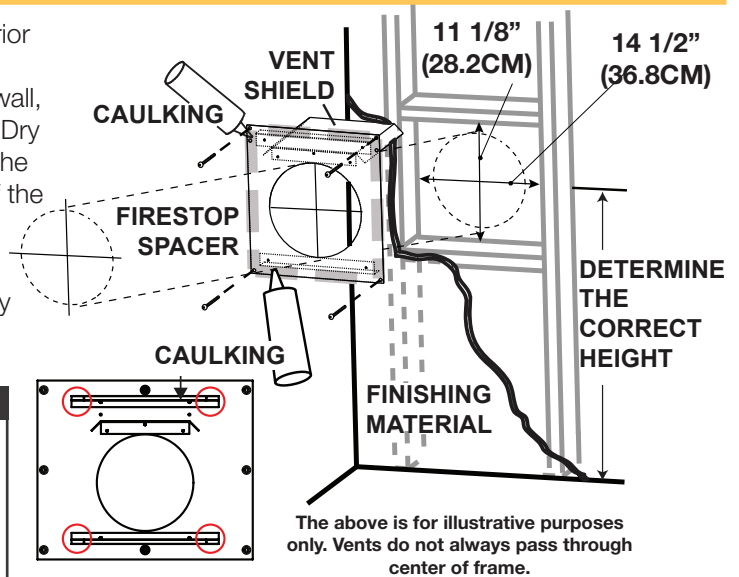

- Fold the vent shield up so that it is perpendicular to the spacer plate.
- Bend the tabs located on either side of the vent shield so that they are just shy of 90° to the spacer plate.
- On both sides of the firestop, fasten the (W570-0018) screws through the clearance holes in the bend tabs and threaded into the holes in the vent shield.
- Apply a bead of caulking around the outer edge of the firestop assembly.
- Screw the firestop onto the wall/framing, using 4 screws.
- Once the vent pipe is installed in its final position, apply red RTV silicone (W573-0002) (not supplied) between the pipe and the firestop.

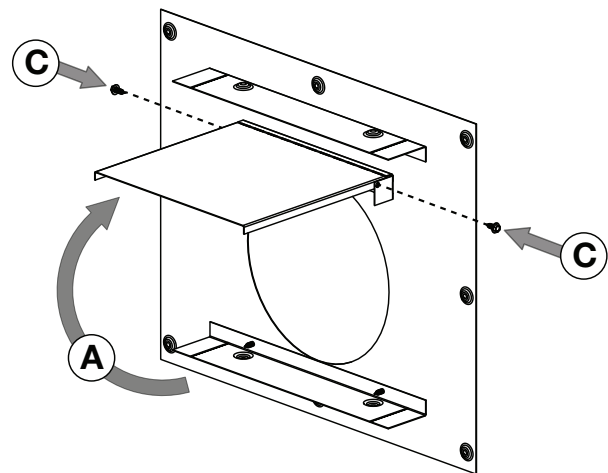

#### note:

Where the venting passes horizontally through a wall, you **MUST** use a Wolf Steel firestop for all rigid and flex vent systems. The gap between the outside diameter of the vent and the firestop **MUST** be completely sealed with high temperature RTV. When using flex venting, use firestop assembly W010-3440 (not supplied). When using rigid venting, use firestop assembly 4DHFSN (not supplied).

## 4.2 vertical installation

This application occurs when venting through a roof. Installation kits for various roof pitches are available from your authorized dealer / distributor. See the “accessories” section to order specific kits required.

- A. Determine the air terminal location, cut and frame a square opening, as illustrated, in the ceiling and the roof to provide the minimum 1" (25mm) clearance between the vent pipe and any combustible material. Try to center the vent pipe location midway between two joists to prevent having to cut them. Use a plumb bob to line up the center of the openings. A vent pipe shield will prevent any materials such as insulation, from filling up the 1" (25mm) air space around the pipe. Nail headers between the joist for extra support.
- B. Apply a bead of caulking (not supplied) to the framework or to the Wolf Steel vent pipe shield plate or equivalent (in the case of a finished ceiling), and secure over the opening in the ceiling. A firestop must be placed on the bottom of each framed opening in a roof or ceiling that the venting system passes through. Apply a bead of caulking all around and place a firestop spacer over the vent shield to restrict cold air from being drawn into the room or around the fireplace. Ensure that both spacer and shield maintain the required clearance to combustibles. Once the vent pipe is installed in its final position, apply red RTV silicone (W573-0002) (not supplied) between the pipe and the firestop assembly.
- C. In the attic, slide the vent pipe collar down to cover up the open end of the shield and tighten. This will prevent any materials, such as insulation, from filling up the 1" (25mm) air space around the pipe.

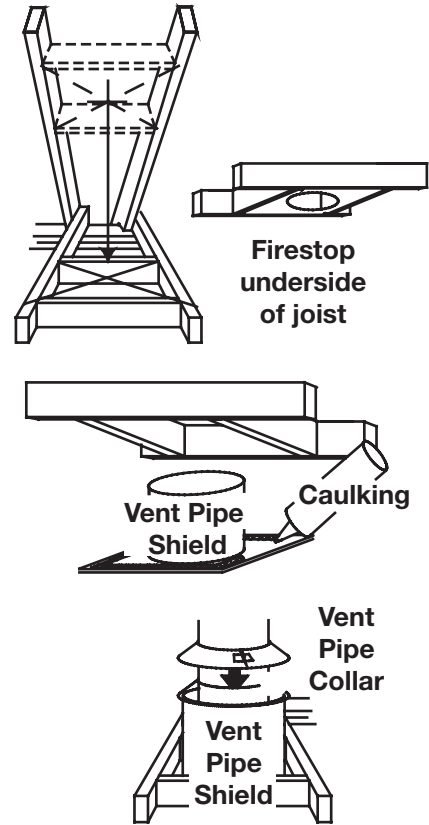

**note:**

When the venting passes vertically through a ceiling, you may use either Wolf Steel firestops or the venting manufacturer’s firestops for rigid venting, provided they follow the required clearances listed in the appliance installation manual. For Wolf Steel flexible venting, you **MUST** use the Wolf Steel firestops listed below.

**For 4”/7” appliances:**

- When using flex venting, use firestop assembly W500-0292 (not supplied).
- When using rigid venting, use firestop assembly 4DFS (not supplied).

**For 5”/8” appliances:**

- When using flex venting, use firestop assembly W500-0028 (not supplied).
- When using rigid venting, use firestop assembly 5DFS (not supplied).

# venting installation

## 4.3 using either flexible or rigid vent components

### ! WARNING

- Do not allow the inner flex pipe to bunch up on horizontal or vertical runs and elbows. Keep it pulled tight.
- Spacers are attached to the inner flex pipe at predetermined intervals to maintain an even air gap to the outer flex pipe. This gap is required for safe operation. A spacer is required at the start, middle, and end of each elbow to ensure this gap is maintained. These spacers must not be removed.

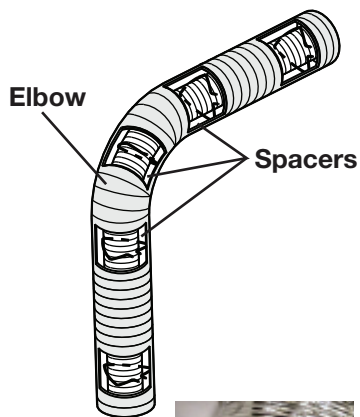

For safe and proper operation of the appliance, follow the venting instructions exactly.

The vent system must be supported approximately every 3 feet (0.9m) for both vertical and horizontal runs. Use Wolf Steel Ltd. support ring assembly or equivalent noncombustible strapping to maintain the minimum clearance to combustibles for both vertical and horizontal runs.

All inner flex pipe and outer flex pipe joints may be sealed using high temperature red RTV silicone W573-0002 (not supplied) or the high temperature sealant W573-0007 Mill Pac (not supplied). However, the high temperature sealant W573-0007 Mill Pac (not supplied) must be used on the joint connecting the inner flex pipe and the exhaust flue collar.

**Use only approved flexible vent pipe kits marked:**

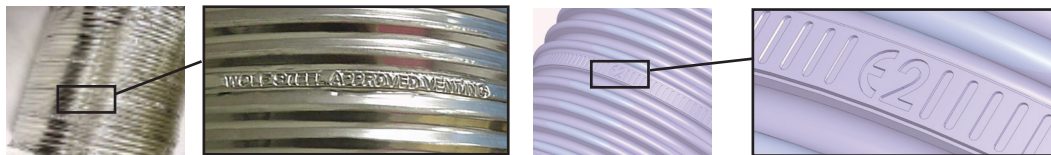

**“Wolf Steel Approved Venting” or “E2” as identified by the stamp only on the flex pipes.**

### 4.3.1 horizontal air terminal installation

- Stretch the inner flex pipe to the required length taking into account the additional length needed for the finished wall surface. Apply a heavy bead of the red RTV silicone (W573-0002) (not supplied) to the inner sleeve of the air terminal. Slip the vent pipe a minimum of 2" (50.8mm) over the inner sleeve of the air terminal and secure with a minimum of 3 screws.
- Using the outer flex pipe, slide over the outer combustion air sleeve of the air terminal and secure with a minimum of 3 screws. Seal using red RTV silicone (W573-0002) (not supplied).
- Insert the vent pipes through the firestop maintaining the required clearance to combustibles. Holding the air terminal (lettering in an upright, readable position), secure to the exterior wall and make weather tight by sealing with caulking (not supplied).
- If more vent pipe needs to be used to reach the fireplace, couple them together, as illustrated. The vent system must be supported approximately every 3 feet (0.9m) for both vertical and horizontal runs. Use non-combustible strapping to maintain the minimum clearance to combustibles.
- Stove Appliances Only:** From inside the house, using Red RTV Silicone (W573-0002) (not supplied), seal between the vent pipe and the firestop. Then slide the black trim collar over the vent pipe up to the firestop.

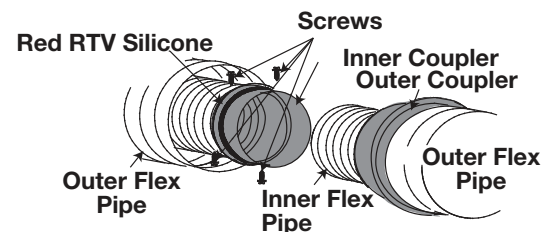
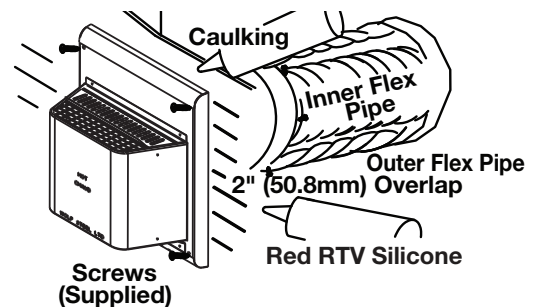

**The air terminal mounting plate may be recessed into the exterior wall or siding no greater than the depth of its return flange.**

### 4.3.2 vertical air terminal installation

## ! WARNING

- Maintain a minimum 2" (51mm) space between the air inlet base and the storm collar.

**note:**

Fastening hardware provided with appropriate roof terminal and liner kits.

- A. Fasten the roof support to the roof using 6 screws. The roof support is optional. In this case, the venting is to be adequately supported using either an alternate method suitable to the authority having jurisdiction or the optional roof support.
- B. Stretch the inner flex pipe to the required length. Slip the inner flex pipe a minimum of 2" (51mm) over the inner pipe of the air terminal connector and secure with a minimum of three screws, when 4/7, 5/8 and 3/5 venting is used and a minimum of six screws when using 8/10 or 8/11 venting. Seal using a heavy bead of red RTV silicone sealant (W573-0002) (not supplied).
- C. Repeat using the outer flex pipe, using a heavy bead of red RTV silicone sealant (W573-0002) (not supplied) and a minimum of three screws, when 4/7, 5/8 and 3/5 venting is used and a minimum of six screws when using 8/10 or 8/11 venting.
- D. Thread the air terminal connector / vent pipe assembly down through the roof. The air terminal must be positioned vertically and plumb. Attach the air terminal connector to the roof support, ensuring that the top of the air terminal is 16" (40.6cm) above the highest point that it penetrates the roof.
- E. Remove nails from the shingles, above and to the sides of the air terminal connector. Place the flashing over the air terminal connector leaving a min. 3/4" (19mm) of the air terminal connector showing above the top of the flashing. Slide the flashing underneath the sides and upper edge of the shingles. Ensure that the air terminal connector is properly centered within the flashing, giving a 3/4" (19mm) margin all around. Fasten to the roof. Do not nail through the lower portion of the flashing. Make weather-tight by sealing with caulking. Where possible, cover the sides and top edges of the flashing with roofing material.
- F. Aligning the seams of the terminal and air terminal connector, place the terminal over the air terminal connector making sure the vent pipe goes into the hole in the terminal. Secure with a minimum of three screws, when 4/7, 5/8 and 3/5 venting is used and a minimum of six screws when using 8/10 or 8/11 venting.
- G. Apply a heavy bead of weatherproof caulking 2" (51mm) above the flashing. Install the storm collar around the air terminal and slide down to the caulking. Tighten to ensure that a weather-tight seal between the air terminal and the collar is achieved.
- H. If more vent pipe needs to be used to reach the appliance, see "**horizontal air terminal installation**" section.

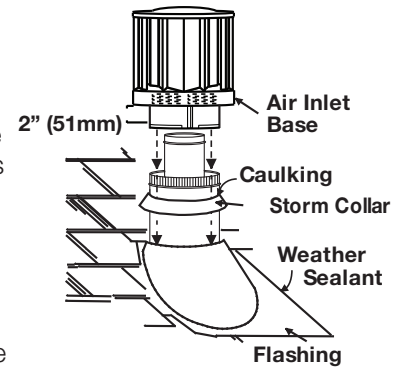
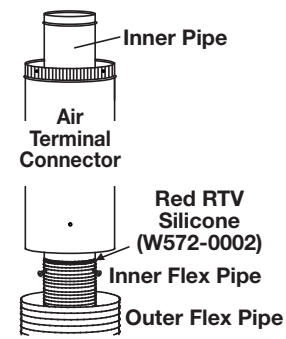
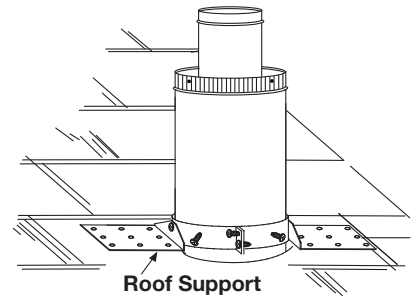

### 4.3.3 appliance vent connection

- A. Install the inner flex pipe to the appliance. Secure with a minimum of three screws when installing 3"/5", 4"/7" or 5"/8" venting, or six screws when installing 8"/10" or 8"/11" venting. Seal the joint and screw holes using Mill Pac sealant (W573-0007) (not supplied).
- B. Install the outer flex pipe to the appliance. Secure with a minimum of three screws when installing 3"/5", 4"/7" or 5"/8" venting, or six screws when installing 8"/10" or 8"/11" venting. Seal the joints using high temperature red RTV silicone (W573-0002) (not supplied).

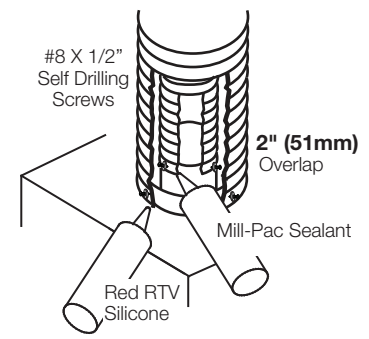

## venting installation

### 4.3.4 horizontal air terminal installation

- A. Move the appliance into position. Measure the vent length required between terminal and appliance taking into account the additional length needed for the finished wall surface and any 2" (50.8mm) overlaps between venting components.
- B. Apply a heavy bead of Mill Pac sealant (W573-0007) (not supplied) to the outer edge of the inner collar of the appliance. Attach the first inner rigid pipe component and secure using a minimum of three screws. Repeat using the outer rigid pipe. Seal using Red RTV Silicone (W573-0002) (not supplied).
- C. Insert the vent pipes through the firestop maintaining the required clearance to combustibles. Apply a heavy bead of Red RTV Silicone (W573-0002) (not supplied) to both the inner sleeve and outer sleeve of the air terminal. Slide the terminal sleeves into the rigid pipes a minimum of 1 1/4". Holding the air terminal (lettering in an upright, readable position), secure to the exterior wall and make weather tight by sealing with caulking (not supplied).

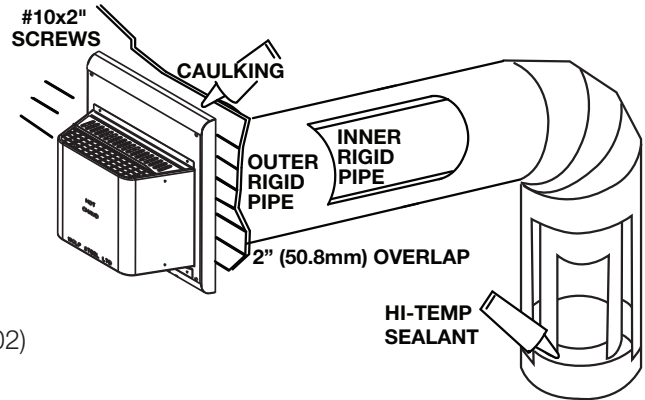

**The air terminal mounting plate may be recessed into the exterior wall or siding no greater than the depth of the return flange.**



### 4.3.5 vertical air terminal installation

## ! WARNING

- Maintain a minimum 2" (51mm) space between the air inlet base and the storm collar.

**note:**

Fastening hardware provided with appropriate roof terminal and liner kits.

Before attaching elbows to the collars on the back of the appliance, 1 1/2" (38.1mm) will need to be trimmed off the 4" (101.6mm) collar.

**REAR VENT APPLICATIONS ONLY:** Attach 4" (101.6mm) and 7" (177.8mm) elbows to the appliance. Secure with 3 screws and seal the joints and screw heads using high temperature sealant. Proceed to step A below.

**TOP AND REAR VENT APPLICATIONS:**

- A. Move the appliance into position.
- B. Fasten the roof support to the roof using the screws provided. The roof support is optional. In this case the venting is to be adequately supported using either an alternate method suitable to the authority having jurisdiction or the optional roof support.
- C. Apply high temperature sealant W573-0007 (not supplied) to the outer edge of the inner sleeve of the air terminal. Slip the inner coupler a minimum of 2" (51mm) over the sleeve and secure using 3 screws.
- D. Apply high temperature sealant W573-0002 (not supplied) to the outer edge of the of the outside sleeve of the air terminal connector. Slip the outer coupler over the sleeve and secure as before. Trim the outer coupler even with the inner coupler end.
- E. Thread the air terminal connector / vent pipe assembly down through the roof support and attach, ensuring that a minimum 16" (40.6cm) of air terminal connector will penetrate the roof when fastened. If the attic space is tight, we recommend threading the Wolf Steel vent pipe collar or equivalent loosely onto the air terminal connector / vent pipe assembly as it is passed through the attic. The air terminal connector must be positioned vertically and plumb.
- F. Remove nails from the shingles, above and to the sides of the air terminal connector. Place the flashing over the air terminal connector and slide it underneath the sides and upper edge of the shingles. Ensure that the air terminal connector is properly centered within the flashing, giving a 3/4" (19.1mm) margin all around. Fasten to the roof. **Do NOT nail through the lower portion of the flashing.** Make weather-tight by sealing with caulking. Where possible, cover the sides and top edges of the flashing with roofing material.
- G. Apply a heavy bead of waterproof caulking 2" (51mm) above the flashing. Install the storm collar around the air terminal and slide down to the caulking. Tighten to ensure that a weather-tight seal between the air terminal connector and the collar is achieved.
- H. Continue adding rigid venting sections, sealing and securing as above. Attach the inner collapsed telescopic sleeve to the last section of rigid piping. Secure with screws and seal. Repeat using the outer telescopic sleeve.
- I. Run a bead of high temperature sealant W573-0007 (not supplied) around the outside of the **inner elbow for rear vent applications** or the **inner collar for top vent applications**. Pull the telescopic sleeve a minimum of 2" (51mm) onto the elbow. Secure with three screws. Repeat with the outer telescopic sleeve.

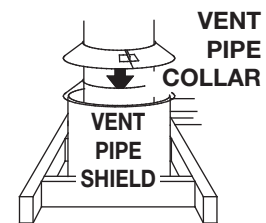
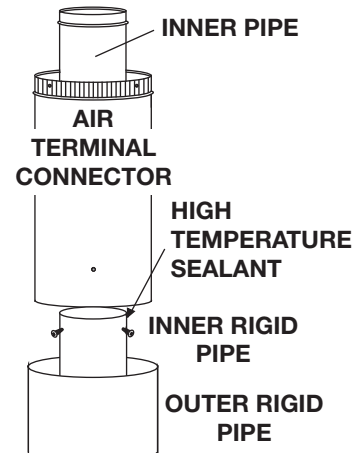

**TOP VENT APPLICATIONS ONLY:**

- K. In the attic, slide the vent pipe collar down to cover up the open end of the shield and tighten. This will prevent any materials, such as insulation, from filling up the 1" (25mm) air space around the pipe.

# venting installation

## 4.4 vertical through existing chimney

### ! WARNING

- Risk of fire.
- Co-axial to co-linear venting configurations must only be used in a non-combustible chimney or enclosure. Installation in a combustible enclosure could result in a fire.

This appliance is designed to be attached to a 3" (76.2mm) co-linear aluminum flex vent system running the full length of a masonry chimney.

The flex liners accommodate any contours of a masonry chimney, however, it is necessary to keep the flexible liners as straight as possible. The inlet air collar of the termination cap must be connected to the air intake flex liner and the exhaust collar must be connected to the exhaust flexible liner.

Both Simpson Duravent and Selkirk co-linear to co-axial adaptors have been approved on this appliance

#### note:

A vent adaptor will be required directly off the appliance.

Follow vent manufacturer's installation instructions.

Different manufacturer's venting components must not be combined. Once the preferred manufacturer's appliance adaptor has been attached, the remainder of the system must be that of the same manufacturer.

The only exception to this rule is to use Wolf Steel's approved 3" (76.2mm) flex liner and co-linear termination.

\* Measured from appliance flue collar to termination flue collar

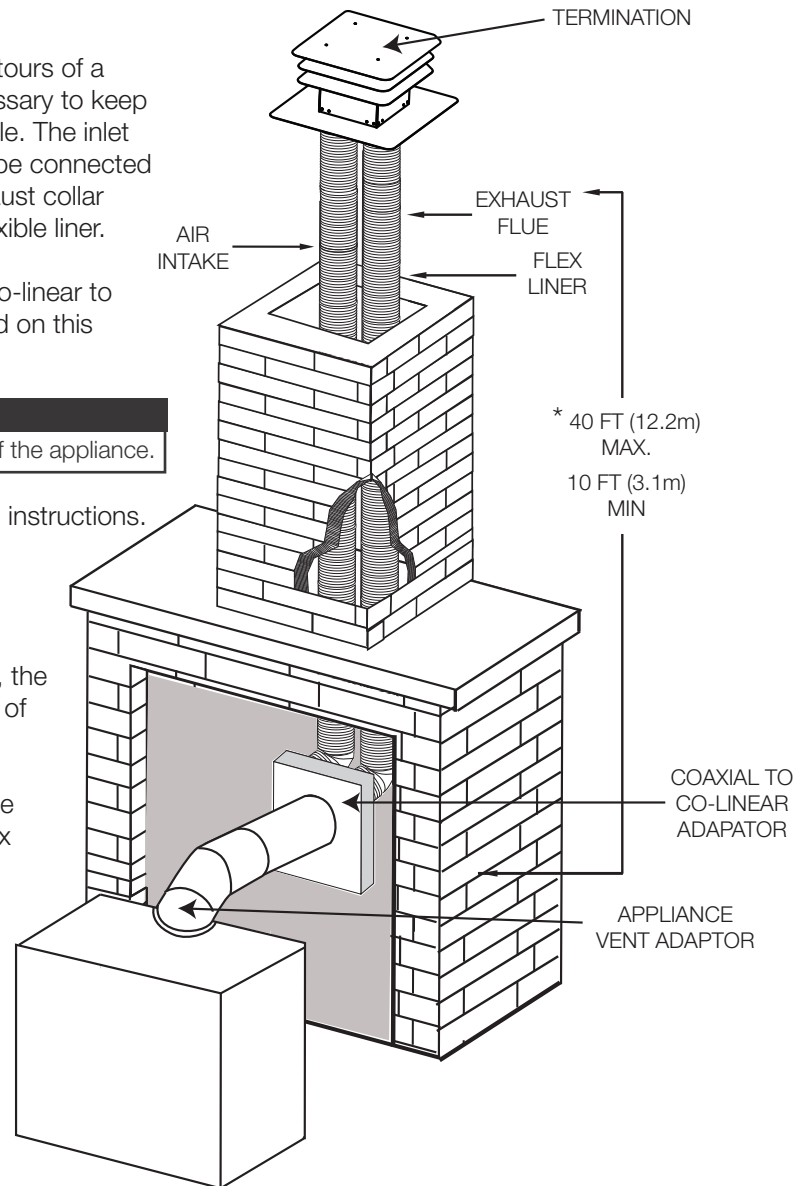



**4.4.1 restricting vertical vents**

**! WARNING**

- Turn off gas and electrical supply before servicing the appliance.
- Appliance may be hot, do not service until appliance is cool.
- For safe and proper operation of the appliance, follow the venting instruction exactly.
- To avoid danger of suffocation, keep the packaging bag away from babies and children. Do not use in cribs, beds, carriages or play pens. This bag is not a toy. Knot before throwing away.

Vertical installations may display a very active flame. If this appearance is not desirable, the exhaust outlet may be restricted with a Wolf Steel approved restrictor kit. This kit is not recommended for short vertical vent runs.

Depending on the model and/or year of your appliance, mounting holes may not exist.

- If mounting holes exist, remove the screws from the firebox top, align the restrictor plate as illustrated and secure.
- If mounting holes do not exist, align the restrictor plate as illustrated and secure using the 2 #8x1/2 hex head sheet metal screws supplied.
- Ensure the plate will pivot at the slot up into the exhaust outlet.
- Depending on the amount of restriction desired, the restrictor plate can be left flat for most restriction or bent up for varying degrees of restriction.

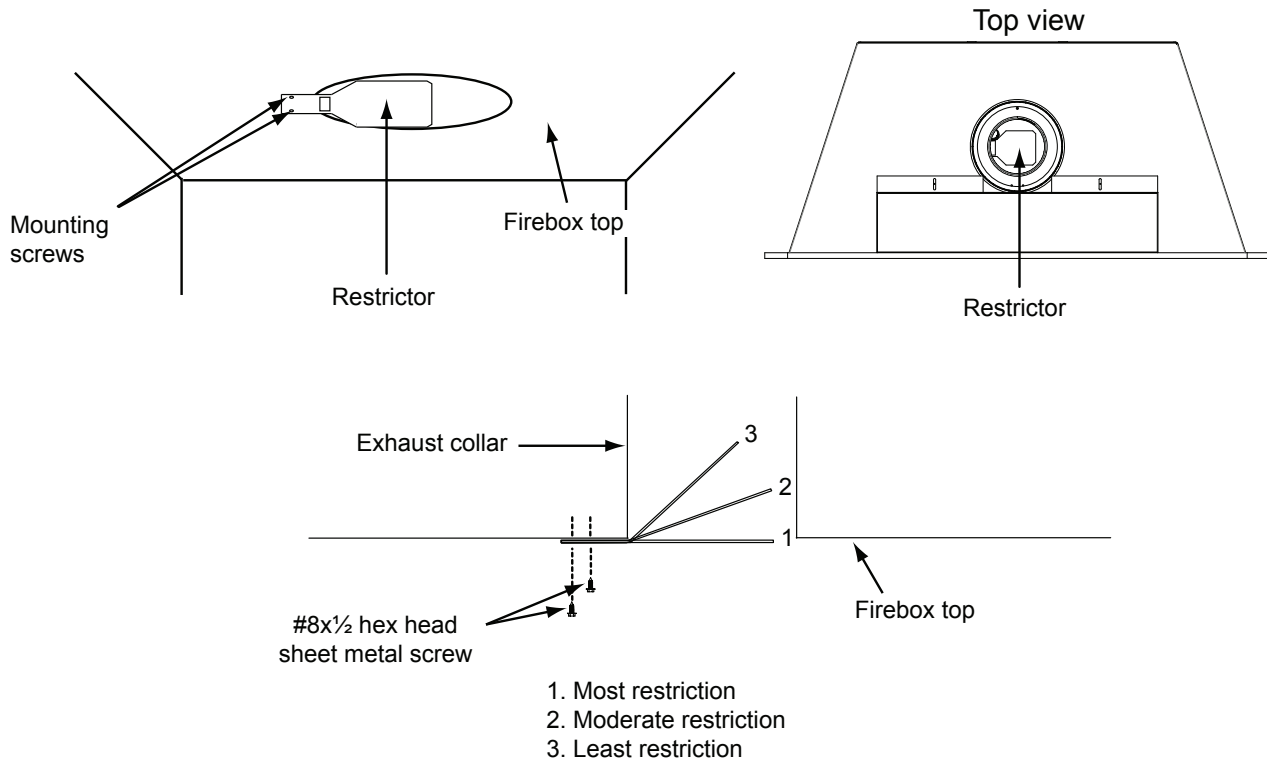

## 5.0 electrical information

### 5.1 hard wiring connection

It is necessary to hard wire this appliance.

This appliance must be electrically connected and grounded in accordance with local codes. In the absence of local codes, use the current CSA C22.1 Canadian Electrical Code in Canada or the ANSI/NFPA 70-1996 National Electrical Code in the United States.

### 5.2 receptacle wiring diagram

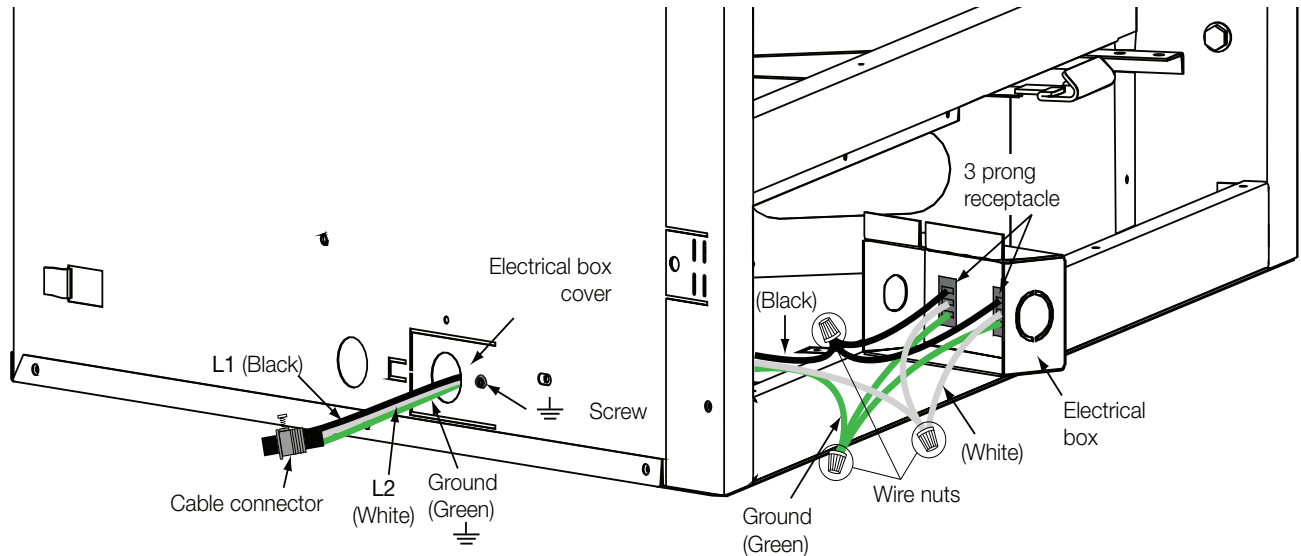

### 5.3 electronic wiring diagram

#### **! WARNING**

- Do not use this appliance if any part has been under water. Call a qualified service technician immediately to have the appliance inspected for damage to the electrical circuit.
- Risk of electrical shock or explosion. Do not wire 110V to the valve or to the appliance wall switch. Incorrect wiring will damage controls.
- All wiring should be done by a qualified electrician and shall be in compliance with local codes. In the absence of local codes, use the current CSA22.1 Canadian Electric Code in Canada or the current National Electric Code ANSI/NFPA NO. 70 in the United States.
- Always light the pilot whether for the first time or if the gas supply has run out, with the glass door opened or removed.

## 5.4 battery back-up installation

### **!** WARNING

- Ensure the gas and electrical power to the appliance is turned off.
- Appliance may be hot, do not service until the appliance has cooled.

**note:**

In the event of a power failure, your appliance can be operated using a USB power bank as a battery back-up.

- Before beginning installation, turn off the gas and disconnect the electrical power supply from the appliance.
- Remove the safety screen to easily access the control compartment.
- Locate the control board under the firebox.
- Unplug the USB power supply going to the control board and replace it with a USB power bank (not supplied).
- Reinstall the safety screen. The safety screen must be installed at all times during the appliance operation.
- Turn the gas back on to begin operating the appliance.

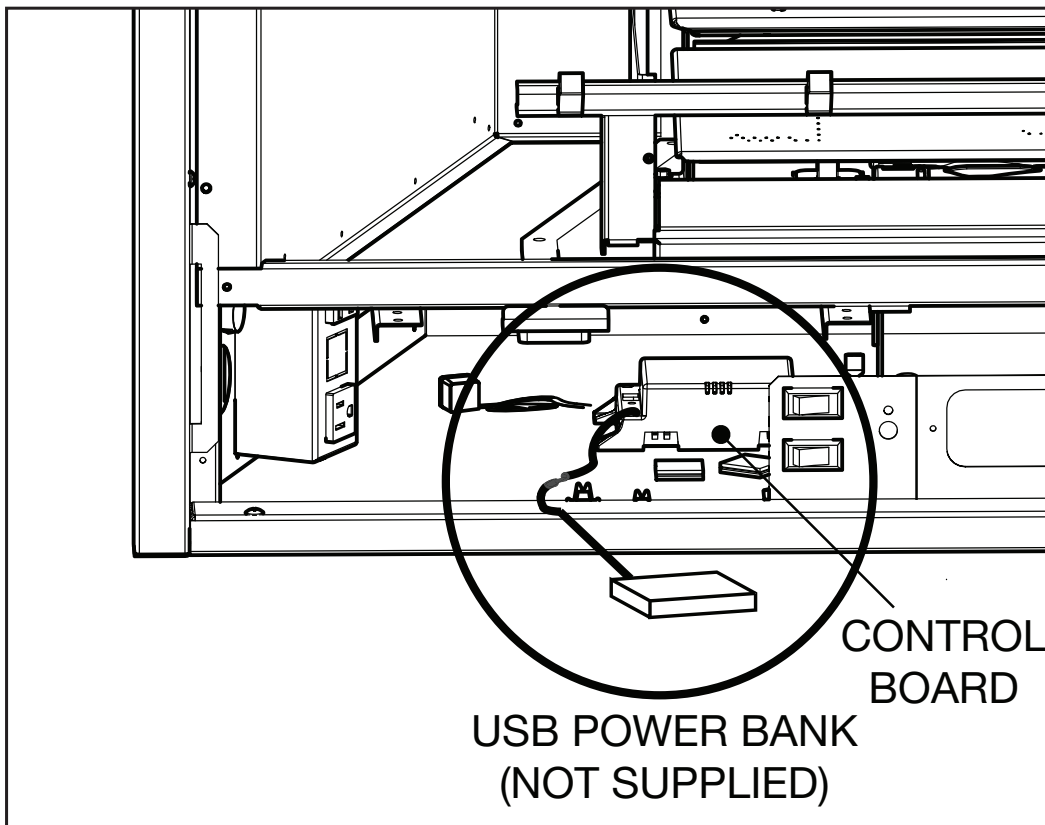

## ! WARNING

- Ensure the gas and electrical power to the appliance is turned off.

- Locate the transmitter and receiver supplied with the appliance.
- Make sure the slide switch on the receiver is set to the “OFF” position.
- Press the battery compartment slightly into the receiver and release enabling the battery compartment to pop out. **(Fig. 1).**
- Place 4 “AA” batteries into the battery compartment and slide the compartment back into the receiver. **(Fig. 2).**
- Connect the receiver wires to the two leads from the control module, identified as switch wires. See “wiring diagram” section.
- Place 2 “AAA” batteries into the battery compartment of the transmitter **(Fig. 3).**
- Slide the switch on the receiver to the “REMOTE” position. The low battery indicator on the receiver will flash and the receiver will beep twice. The receiver is now ready to communicate with the transmitter. You only have 30 seconds after the receiver is put in the “REMOTE” position to capture the code, which will be indicated by three beeps from the receiver.
- Point the transmitter at the receiver, push and hold the “ON” button for 1 to 2 seconds to capture a predetermined code. The low battery indicator on the receiver will flash and the receiver will beep three times to confirm synchronization with the transmitter. At this time the remote should be fully operational.

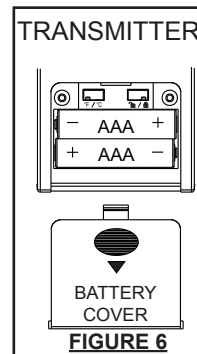
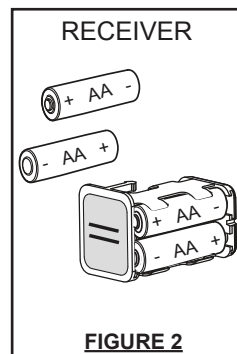
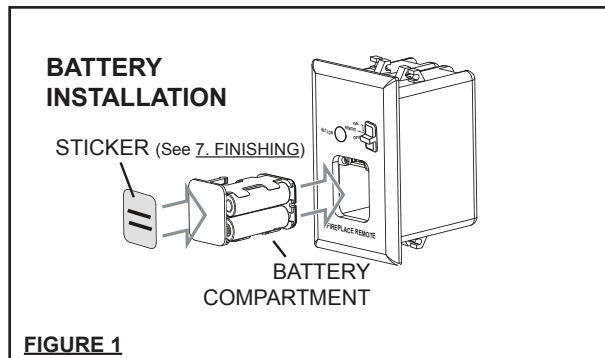

5.6 wiring diagram

**! WARNING**

- Do not wire 110 volts to the valve or wall switch.

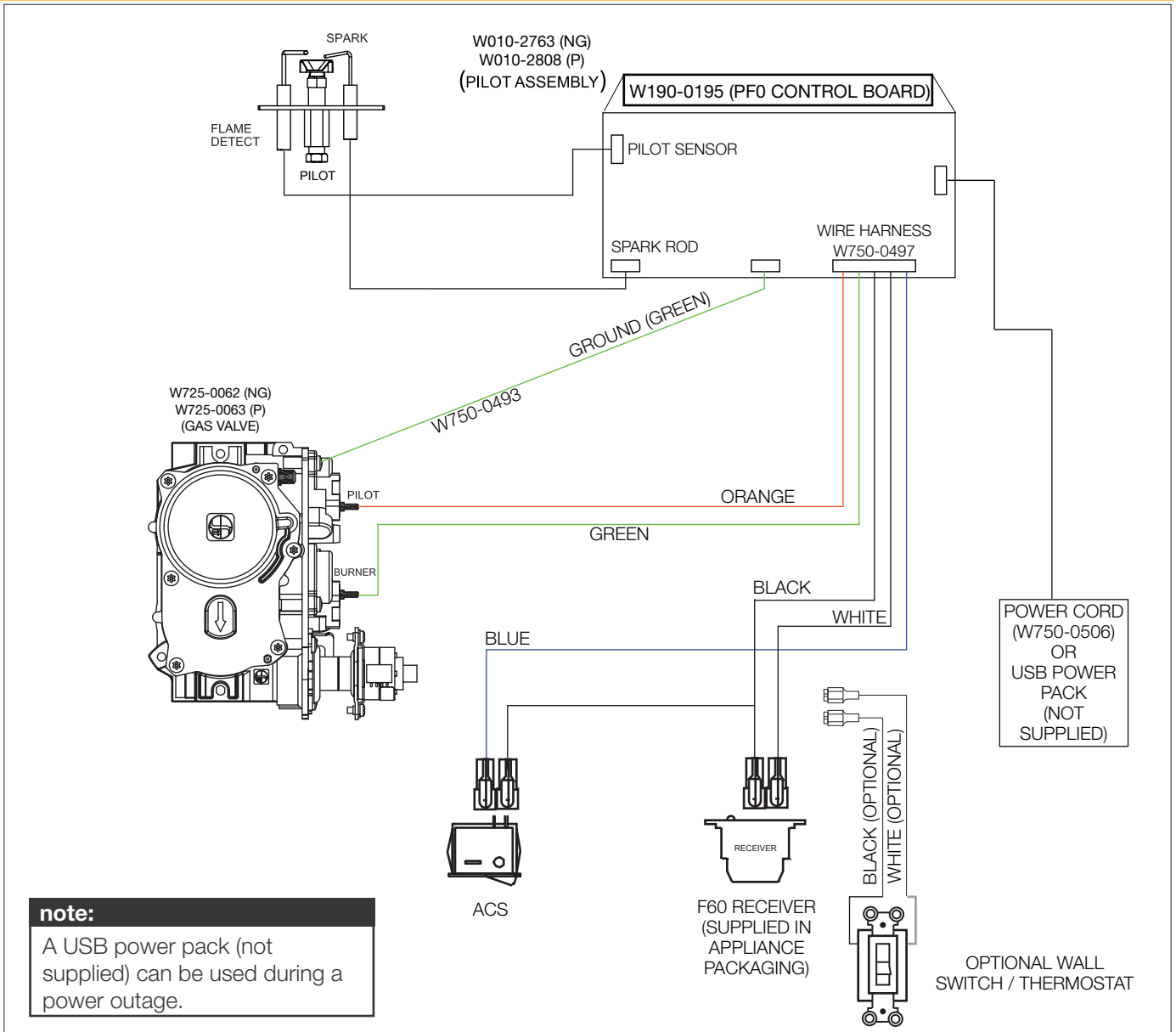

**note:**

A USB power pack (not supplied) can be used during a power outage.

**note:**

The optional wall switch / thermostat should be connected to the piggyback connectors on the back of the receiver.

## 5.7 light &amp; blower assembly wiring diagrams

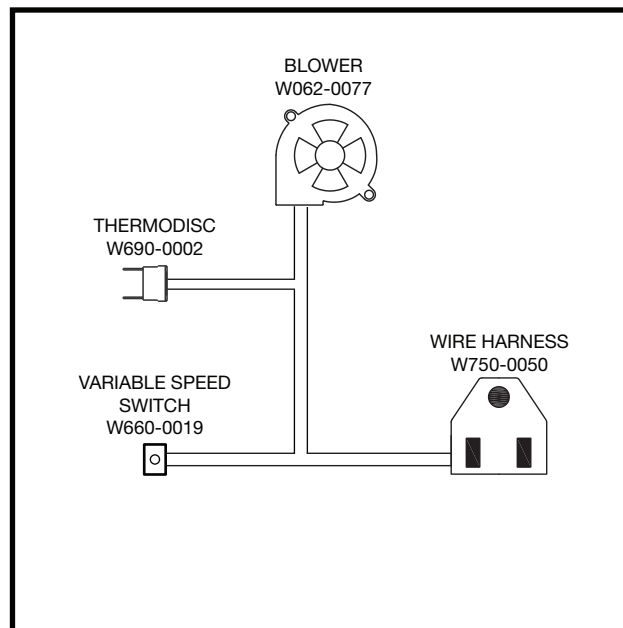
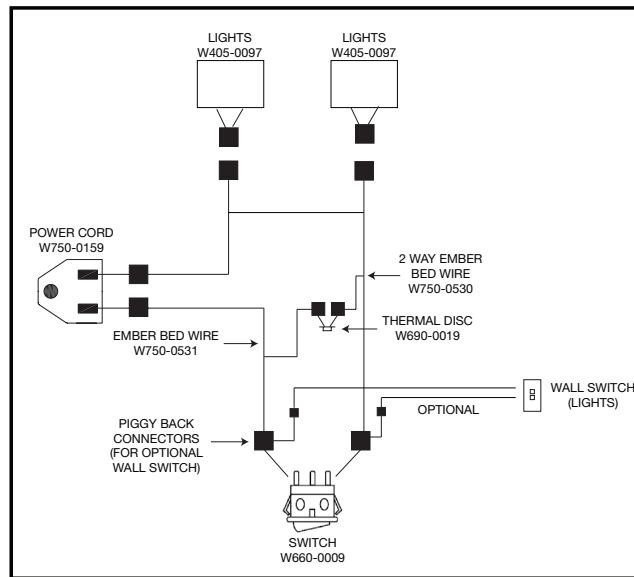
**note:**

For EFCN/P-PF0 installation:

**For the lights:** the switch on the control panel must remain in the ON position.

**For the blower:** the wire harness provided with the kit must be used.

## ! WARNING

- Risk of fire, explosion, or asphyxiation. Ensure there are no ignition sources such as sparks or open flames.
- Support gas control when attaching gas supply pipe to prevent damaging gas line.
- Always light the pilot whether for the first time or if the gas supply has run out with the glass door opened or removed. Purging of the gas supply line should be performed by a qualified service technician. Ensure that a continuous gas flow is at the burner before closing the door. Ensure adequate ventilation. For gas and electrical locations, see “dimensions” section.
- All gas connections must be contained within the appliance when complete (**gas fireplaces only**).
- High pressure will damage valve. Disconnect gas supply piping before testing gas line at test pressures above 1/2 PSIG.
- Valve settings have been factory set, do not change.

### Installation and servicing to be done by a qualified installer.

- Move the appliance into position and secure.
- If equipped with a flex connector, the appliance is designed to accept a 1/2” (13mm) gas supply. Without the connector, it is designed to accept a 3/8” (9.5mm) gas supply. The appliance is equipped with a manual shut off valve to turn off the gas supply to the appliance.
- Connect the gas supply in accordance to local codes. In the absence of local codes, install to the current CAN/CSA-B149.1 Installation Code in Canada or to the current National Fuel Gas Code, ANSI Z223.1 / NFPA 54 in the United States.
- When flexing any gas line, support the gas valve so that the lines are not bent or kinked.
- The gas line flex-connector should be installed to provide sufficient movement for shifting the burner assembly on its side to aid with servicing components.
- Check for gas leaks by brushing on a soap and water solution. **Do not use open flame.**

After installing the electrical wiring and gas lines, ensure to test the appliance before finishing the framing and finishing the appliance.

## 7.0 nailing tab installation

- A. Nailing tabs are provided as part of the frames, as shown. To determine the final location and where to bend the nailing tabs you must first determine the thickness of your finishing material (i.e. drywall). This will determine the dimension from the front edge of the corner post to the nailing tab. Once the nailing tab is in the desired location and secure using an appropriate fastener\*.

\* Additional fasteners may be installed.

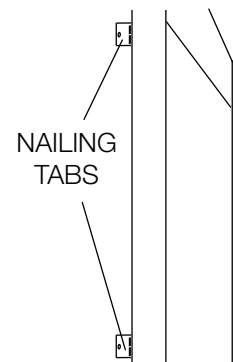

## 8.0 operation

### WARNING

- If you do not follow these instructions exactly, a fire or explosion may result causing property damage, personal injury, or loss of life.
- If applicable, always light the pilot whether for the first time or if the gas supply has run out with the glass door opened or removed.

Ensure that a continuous gas flow is at the burner before installing the door. When lit for the first time, the appliance will emit an odor for a few hours. This is a normal temporary condition caused by the “burn-in” of paints and lubricants used in the manufacturing process and will not occur again. After extended periods of non-operation, such as, following a vacation or warm weather season, the appliance may emit a slight odor for a few hours. This is caused by dust particules in the heat exchanger burning off. In both cases, open a window to sufficiently ventilate the room.

#### FOR YOUR SAFETY READ BEFORE LIGHTING

- Do not turn on if children or other at risk individuals are near the appliance.
- This appliance is equipped with an ignition device which automatically lights the pilot. Do not try to light the pilot by hand.
- Before operating, smell all around the appliance area for gas and next to the floor because some gas is heavier than air and will settle on the floor.
- Do not use this appliance if any part has been under water. Immediately call a qualified service technician to inspect the appliance and replace any part of the control system and any gas control which has been underwater.

#### WHAT TO DO IF YOU SMELL GAS

- Turn off all gas to the appliance.
- Open windows.
- Do not try to light any appliance.
- Do not touch any electric switch; do not use any phone in your building
- Immediately call your gas supplier from a neighbour's phone. Follow the gas supplier's instructions.
- If you cannot reach your gas supplier, call the fire department.

#### LIGHTING INSTRUCTIONS

##### note:

This appliance is equipped with an ignition device which automatically lights the pilot. Do not try to light the pilot by hand.

- Stop! Read the above safety information on this label.
- Remove batteries from the transmitter and set thermostat to lowest setting, if equipped.
- Turn off all electrical power to the appliance.
- Open the glass door, if equipped.
- Turn the manual shut-off valve clockwise to the “OFF” position. (Shut-off valve is located on the flex connector).
- Wait five (5) minutes to clear out any gas. If you smell gas including near the floor, **STOP!** Follow the instructions above in the “WHAT TO DO IF YOU SMELL GAS” section. If you don't smell gas; close the glass door and go to the next step.
- Turn the manual shut-off valve counter clockwise to the “ON” position.
- Turn on all electrical power to the appliance and re-install the batteries into the transmitter. Set thermostat to desired setting, if equipped.
- Turn on the remote wall switch to the appliance.
- If the appliance will not operate, follow instructions “TO TURN OFF GAS” and call your service technician or gas supplier.

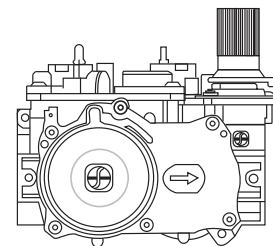

#### TO TURN OFF GAS

- Set thermostat to lowest setting, if equipped.
- Turn off the remote wall switch to the appliance.
- Turn off all electric power to the appliance if service is to be performed.
- Turn manual shutoff valve clockwise to the “OFF” positon. Do not force.



## 8.1 pilot on demand

This appliance is equipped with an “On Demand” intermittent pilot ignition system (IPI) which also includes a continuous pilot ignition (CPI) mode with an integrated seven day timer. This system minimizes your appliance’s carbon footprint as well as reducing its annual fuel consumption and operating costs.

In IPI mode, the pilot will ignite prior to the main burner, when the appliance is turned on using a switch, remote or from a call for heat with the thermostat (if equipped). Once the appliance is turned off (or the call for heat is satisfied), the main burner and pilot flame will shut down.

The continuous (CPI) mode is intended to enhance the performance of the appliance during the startup phase in colder climates and extreme weather by keeping the system warm when the main burner is not in use. However, the timer feature provides the convenience that the appliance automatically switches off the pilot when the appliance has not been used for seven days to save unnecessary fuel consumption.

When the CPI function is turned on, the pilot will remain on after the main burner is turned off. A timer will then begin the countdown for approximately seven days before shutting off the pilot if the appliance is not used. This countdown will reset anytime the appliance main burner is used. Therefore, if the appliance is regularly used day to day, the pilot will remain on. However, this system does not require the user to remember to turn the pilot off as summer approaches and avoids unnecessary fuel consumption while still readily turned back on when the cold weather returns.

**Your appliance may be equipped with an ACS or remote control device (Fig. 1) which enables you to select IPI or CPI modes.**

If your appliance is equipped with an ACS switch, it has the option to change modes:

**Fig. 2:** Flipping the switch ON turns on the continuous pilot with timer and flipping the switch OFF turns on the intermittent pilot ignition.

**Fig. 3:** If installed with the blue wire facing up, flipping the switch UP turns on the continuous pilot with timer and flipping the switch DOWN turns on the intermittent pilot ignition. If installed with the white wire facing up, the opposite is true.

If your appliance is equipped with a remote control device capable of selecting IPI / CPI modes, refer to remote operating instructions.

In order to start your pilot, turning the main burner on with the switch, remote or thermostat and then turning it off will reactivate the continuous pilot mode and reset the seven day timer.

For further information, refer to [www.napoleon.com/pilotondemand](http://www.napoleon.com/pilotondemand).



(Fig. 1)

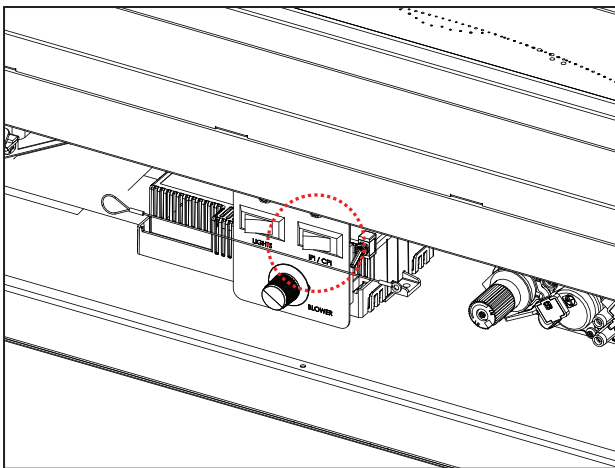

(Fig. 2)

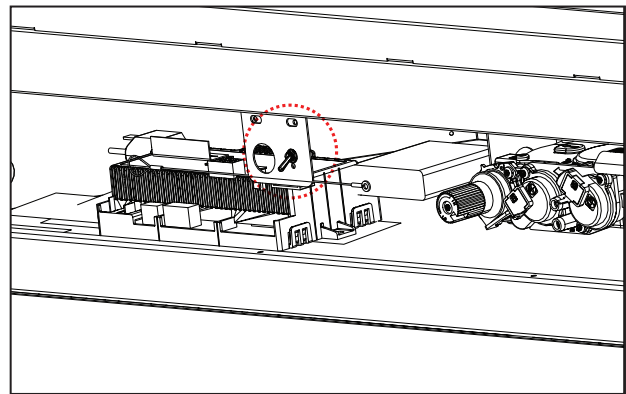

(Fig. 3)

## 9.0 finish framing

### 9.1 flush

#### ! WARNING

- Risk of fire!
- Maintain all specified air space clearances to combustibles. Failure to comply with these instructions may cause a fire or cause the appliance to overheat.
- Ensure all clearances (i.e. back, side, top, vent, mantel, front, etc.) are clearly maintained.

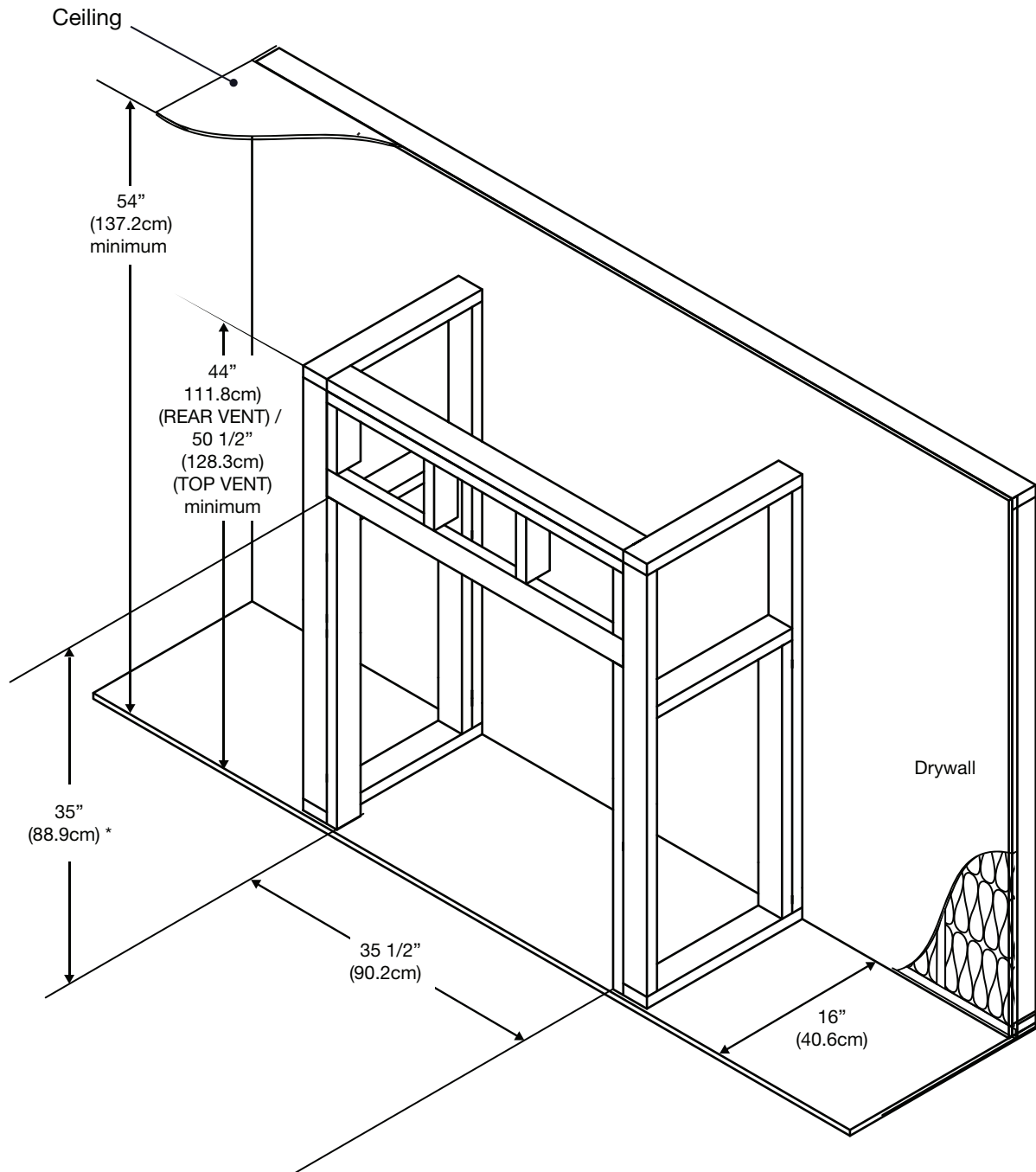

\* Allow for finished floor and hearth thickness when setting these dimensions.

9.2 recess

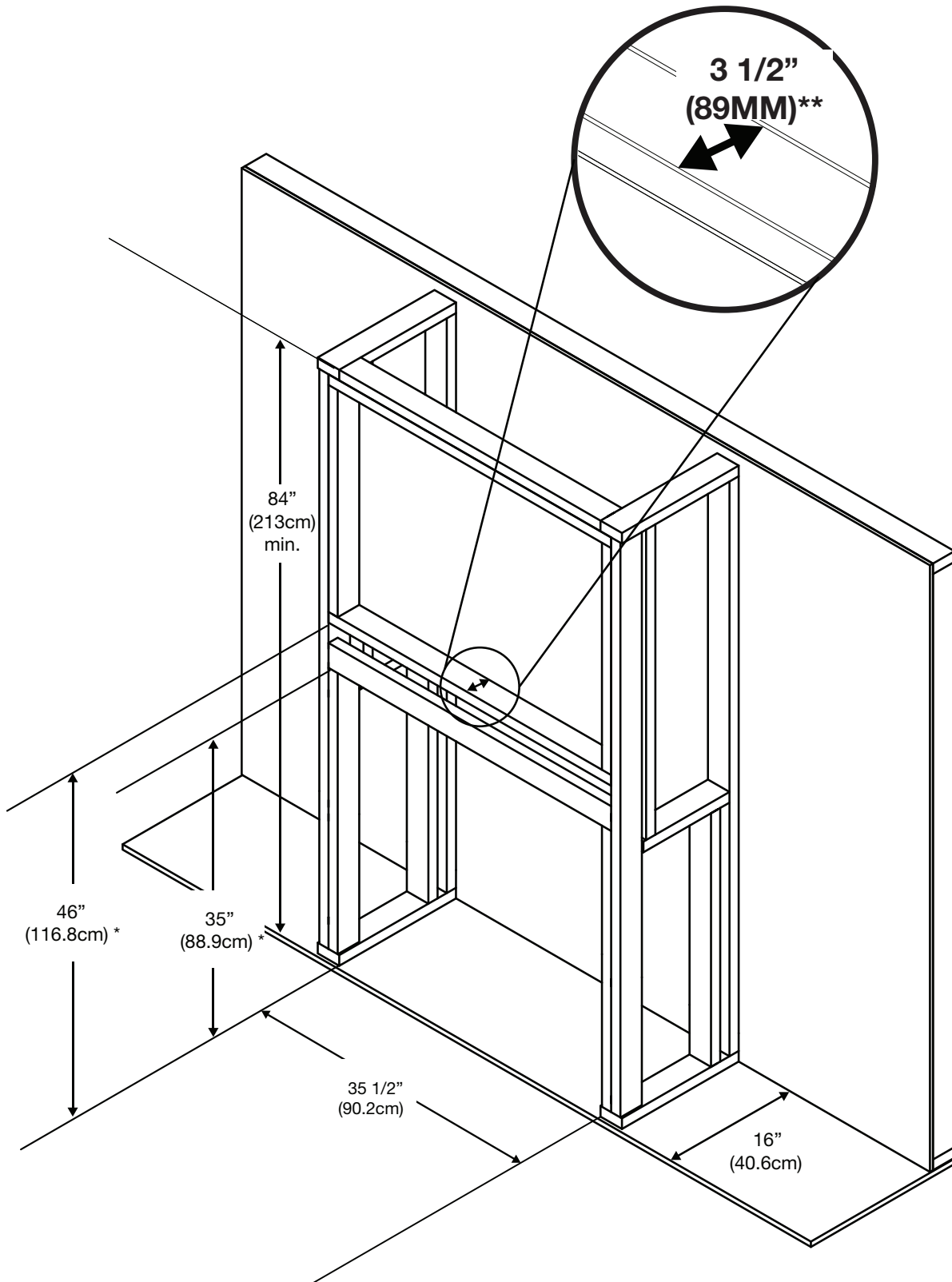

\* Allow for finished floor and hearth thickness when setting these dimensions.

\*\* 2" x 4" frame can be "backed" with 3/4" ply to support TV mounting hardware.

## 10.0 finishing

### **!** WARNING

- Risk of fire!
- Never obstruct the front opening of the appliance.
- The front of the appliance must be finished with any non-combustible materials such as brick, marble, granite, etc., provided that these materials do not go below the specified dimension, as illustrated.
- Do not strike, slam, or scratch. Do not operate appliance with glass removed, cracked, or scratched.
- Facing and/or finishing material must never overhang into the appliance opening.
- The glass door assembly is designed to pivot forward when relieving excess pressure that might occur. Finishing or other materials must not be located in the opening surrounding the door as this will interfere with the doors ability to relieve pressure.

### 10.1 safety barrier / door removal and installation

### **!** WARNING

- Glass may be hot. Do not touch glass until cooled.
- If equipped with door latches that are part of a safety system, they must be properly engaged. Do not operate the appliance with latches disengaged.
- Facing and/or finishing materials must not interfere with air flow through air openings, louvre openings, operation of louvres, or doors/access for service. Observe all clearances when applying combustible materials.
- Before door is removed, turn the appliance off and wait until appliance is cool to the touch. Doors are heavy and fragile so handle with care.

**A barrier designed to reduce the risk of burns from the hot viewing glass is provided for the appliance and shall be installed.**

Before the glass door can be removed, the safety barrier must be removed. Lift the safety barrier off the 4 pins, tilt the top forward and remove from the appliance.

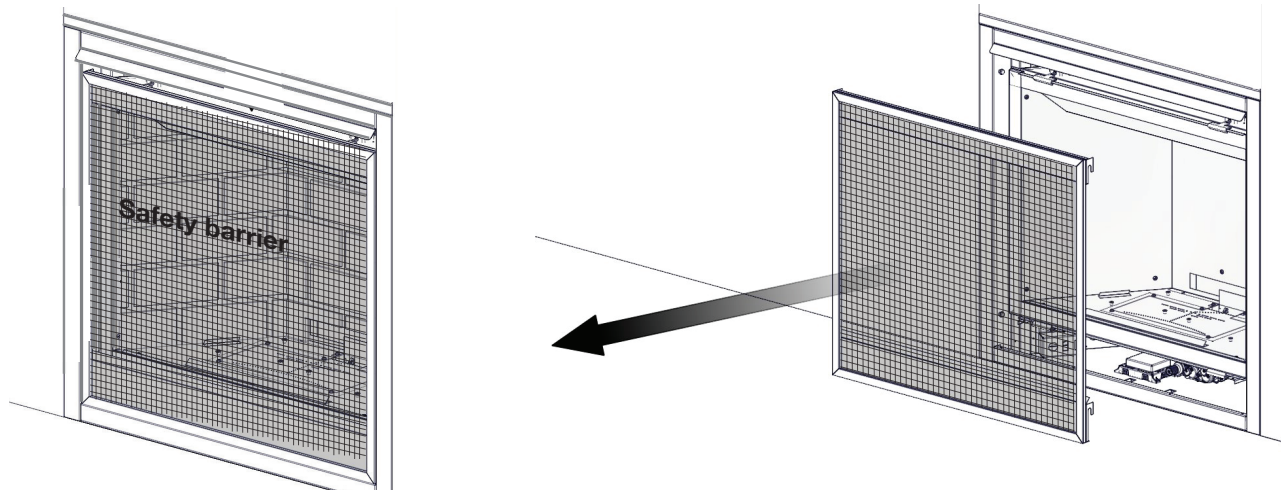

Leave a hand on the glass door during entire door removal. The glass door is secured to the firebox with 2 spring latches along the top and 2 along the bottom. Pull the handles of the latches forward, then lift the latches out from the door frame to release the top of the door. Repeat the same step for the 2 bottom latches. Next, pivot the door forward until the top edge clears the front of the appliance. Carefully grip the sides of the door lifting it off the appliance.

**note:**

These spring latches make up the spring relief system for the appliance. Ensure they open freely and close sealed.

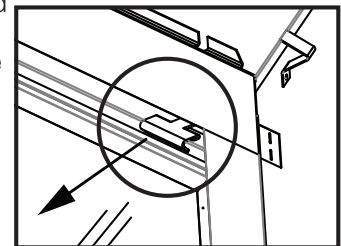

Reverse these steps to re-install the safety barrier and door. Ensure safety barrier is installed correctly.

## 10.2 front hood installation

**note:**

This hood **must** be installed, if it has not already been factory installed.

- A. Safety door and screen must be removed.
- B. Remove the securing screws from the top of the firebox, as shown.
- C. Install the front hood, ensure it is angled downward when installed.
- D. Reinstall the previously removed securing screws.

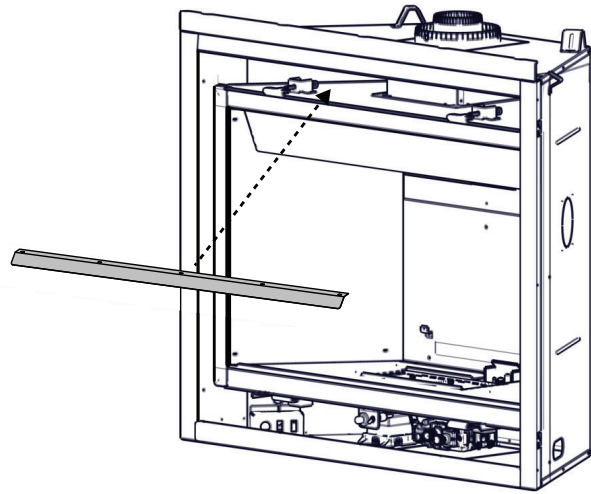
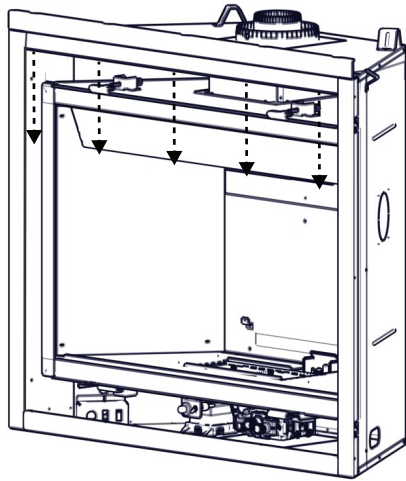

SIDE VIEW

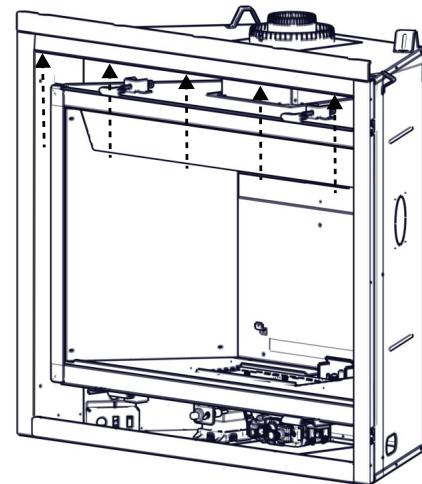
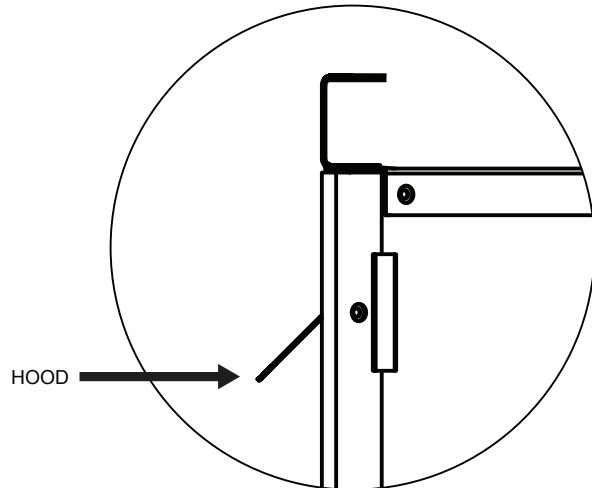

## 10.3 non-combustible facing material

**! WARNING**

Non-combustible facing material must not project more than 4" (101.6mm) from the face of the door (all four sides). If greater projections are desired, increase the clearance to the sides, bottom and top by 2" (50.8mm) for every additional 1" (25.4mm) of projection. If using an optional surround, the same rule applies, starting from the top of the surround. Ensure clearances are maintained for surround removal, as it must lift off the appliance for maintenance.

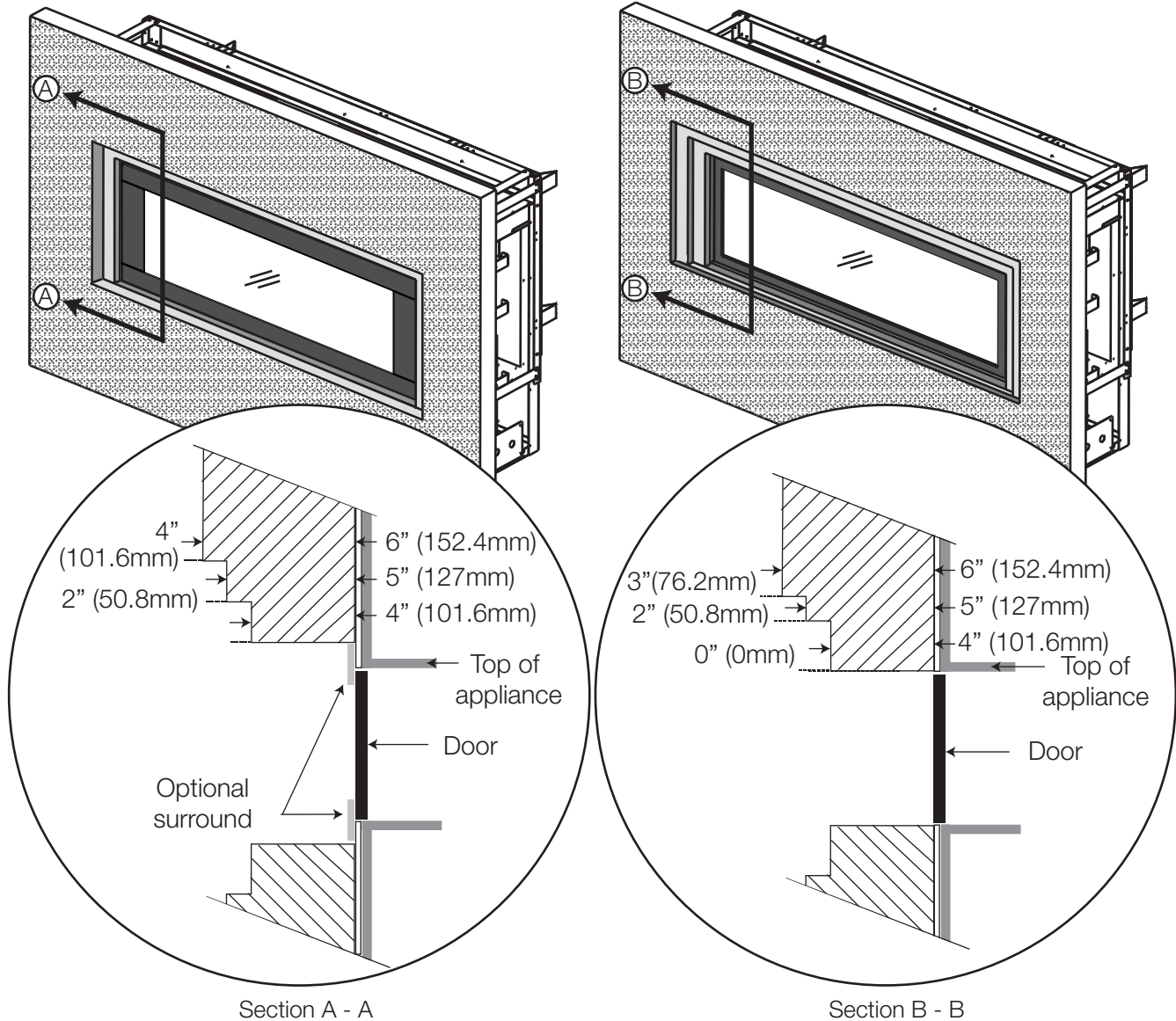

### 10.4 minimum mantel clearances

Combustible mantel clearance can vary according to the mantel depth. Use the graph to help evaluate the clearance needed. These same requirements apply to any combustibles protruding on either side of the appliance.

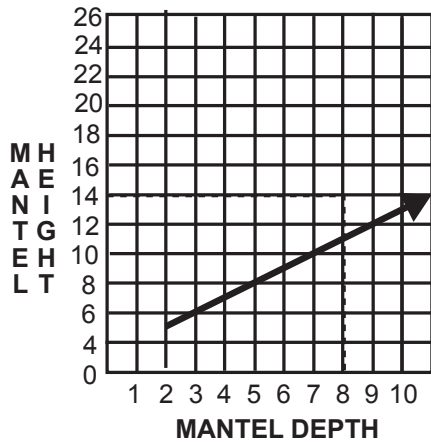

MANTEL DIMENSIONS		
Ref	Height	Depth
<b>A</b>	31 5/8" (80.3cm)	N/A
<b>B</b>	5" (12.7cm)	2" (51mm)
<b>C</b>	7" (17.8cm)	4" (102mm)
<b>D</b>	9" (22.9cm)	6" (152mm)
<b>E</b>	11" (27.9cm)	8" (203mm)

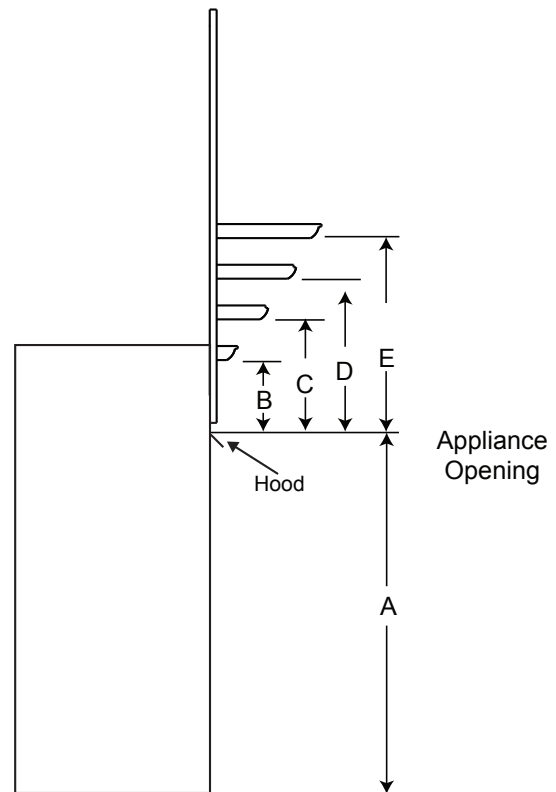



## 10.5 clearances around appliance (TV and valuable objects)

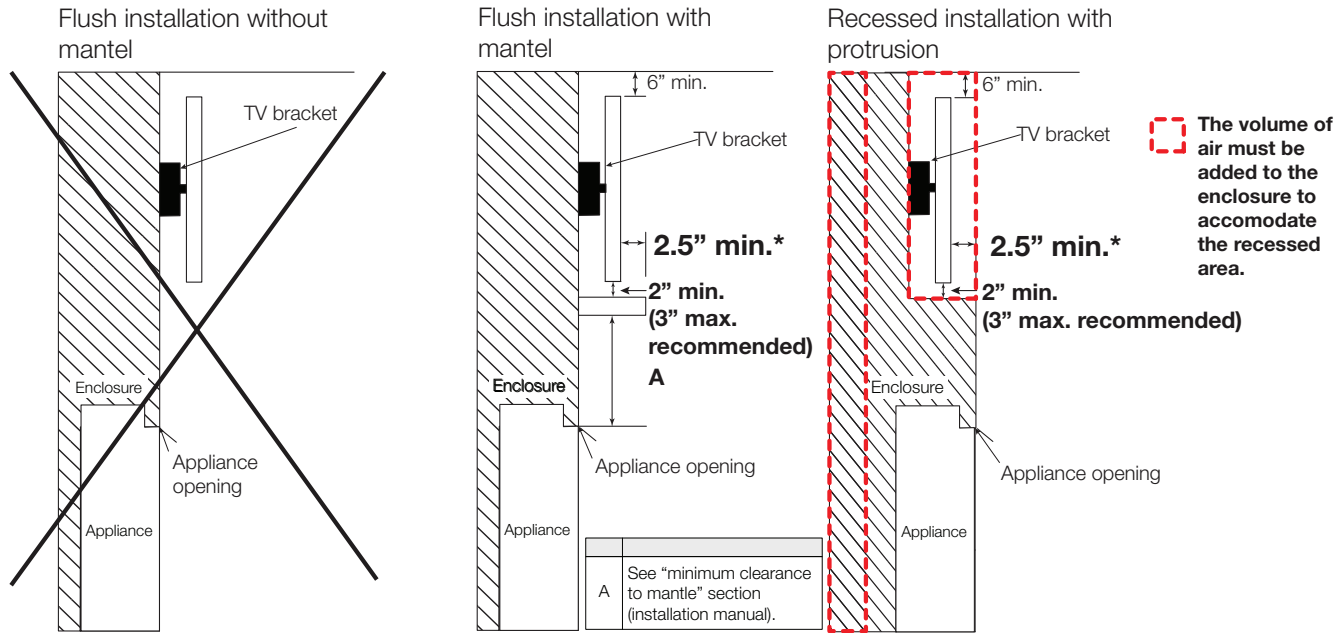

Partially recessed installation with mantel

**WARNING**

This application is only acceptable when the Universal Heat Management kit is installed

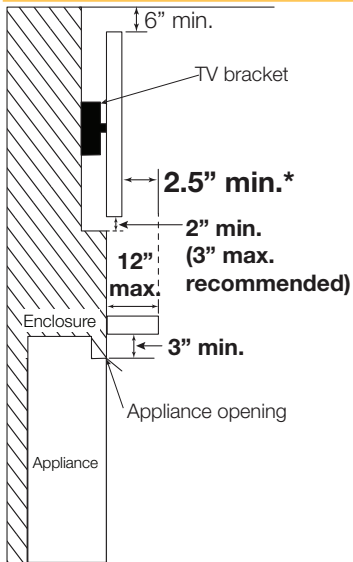
**note:**

- **Electronic appliance temperatures must be validated at the time of installation** as air flow characteristics within the room can vary and maximum acceptable operating temperatures can vary from appliance to appliance. Electronic appliances cannot be used where the electronic appliance temperature exceeds the manufacturer's maximum allowable operating temperatures (see electronic appliance manufacturer's specifications). **Operating a television above the manufacturer's maximum allowable operating temperature will result in premature failure.**
- Mantel height and depth must conform to mantel clearance requirements specified in this manual, see "minimum clearance to combustible mantel" section in installation manual.
- Electronic appliance temperatures may be further reduced by increasing the horizontal distance between the front of the electronic appliance and the front edge of the mantel or by increasing dimension "A". However, increasing the gap between the top of the mantel and the bottom of the electronic appliance beyond the maximum recommended figure, typically results in higher temperatures. Minimum clearance between the mantel and bottom of the electronic appliance should be maintained to allow air circulation below and behind the electronic appliance.

\* TV applications were tested with the minimum enclosure dimensions and the maximum recess permissible. This data is provided in good faith and is not a guarantee for every application and television. Care and consideration should be taken when planning these installations to ensure the temperatures around the TV meet all manufacturer's recommended operating temperatures. Increasing the height of the mantel and/or TV above the fireplace opening, the protrusion of mantel and the volume of the enclosure all have the effect of reducing the temperature above the fireplace. **It is always recommended to use the optional heat management kit when considering mounting a television above the fireplace.**



## 10.6 log placement

**! WARNING**

- Failure to position the logs in accordance with these diagrams or failure to use only logs specifically approved with this appliance may result in property damage or personal injury.
- Logs must be placed in their exact location in the appliance. Do not modify the proper log positions, since appliance may not function properly and delayed ignition may occur.
- The logs are fragile and should be handled with care.

**PHAZER™** logs and glowing embers, exclusive to Napoleon, provide a unique and realistic glowing effect that is different in every installation. Take the time to carefully position the glowing embers for a maximum glowing effect. Log colours may vary. During the initial use of the appliance, the colours will become more uniform as colour pigments burn in during the heat-activated curing process. Blocked burner ports can cause an incorrect flame pattern.

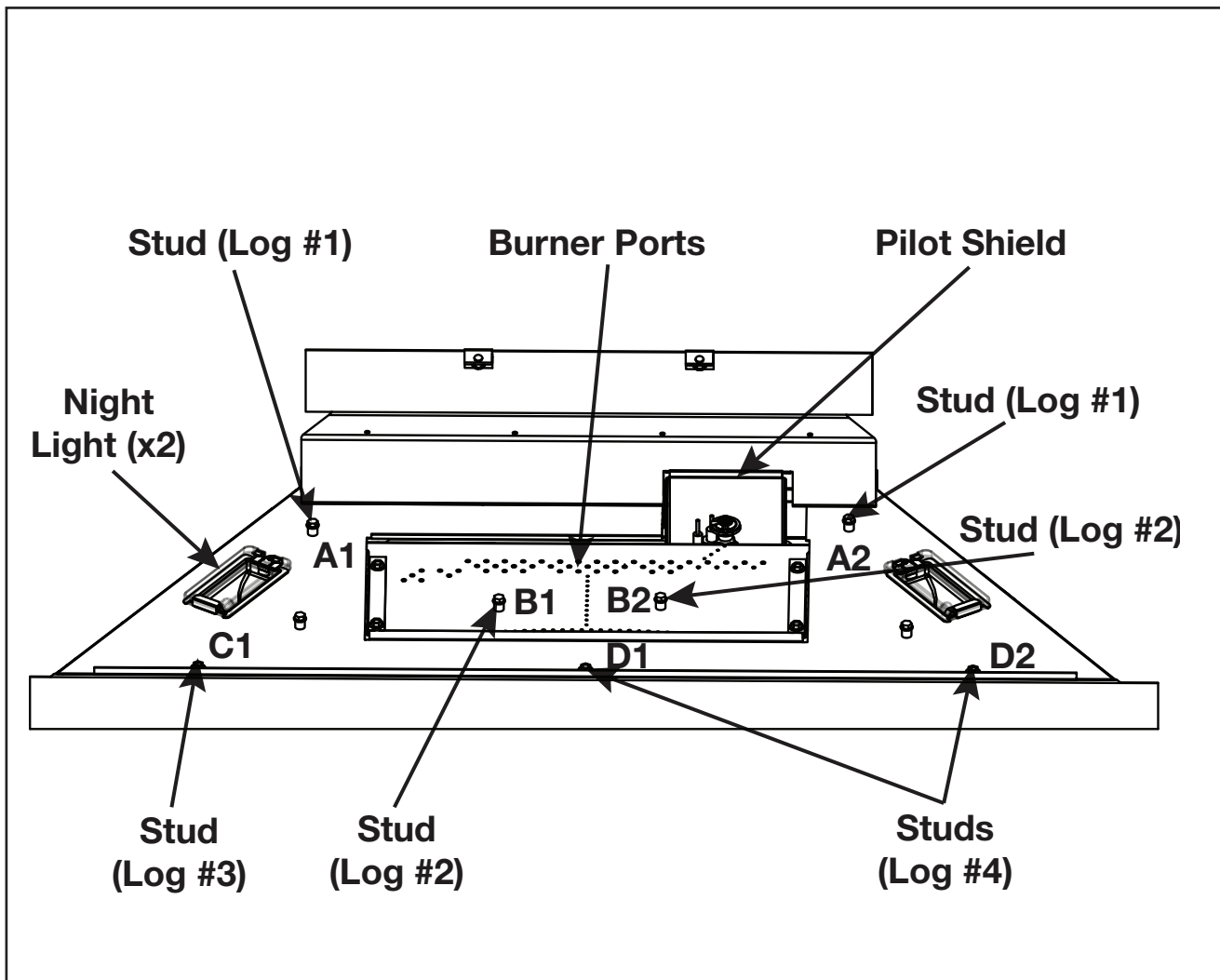

**Burner Overview**

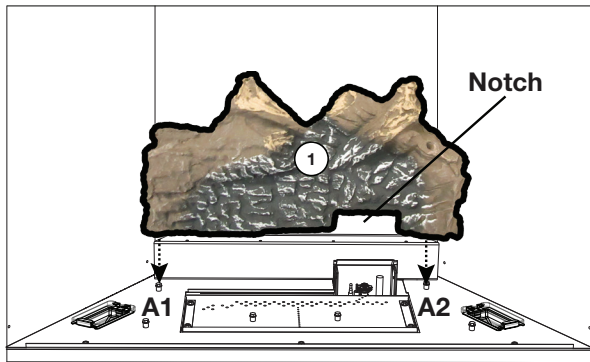

1. Place log #1 (W135-0685) firmly onto A1 and A2, ensuring the notch fits around the pilot shield.

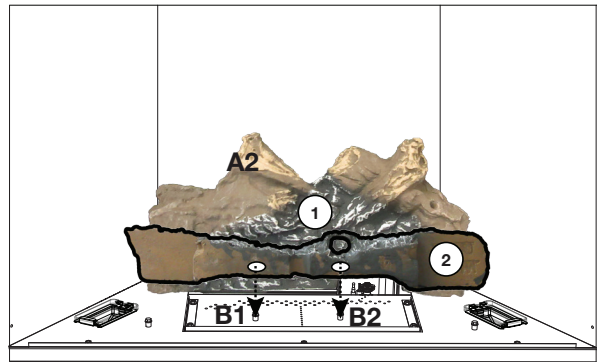

2. Place log #2 (W135-0686) firmly onto B1 and B2. Do not cover any burner ports.

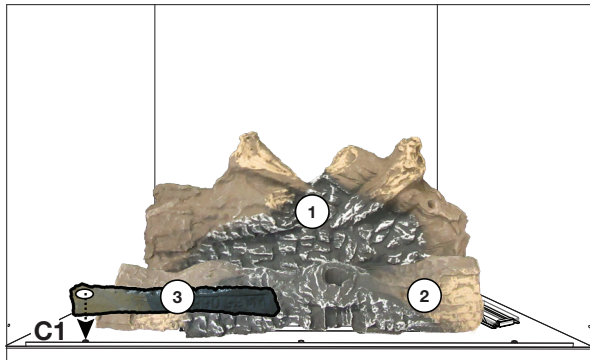

3. Place log #3 (W135-0688) firmly onto C1.

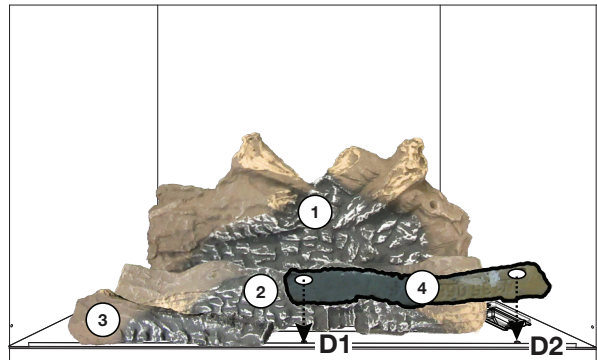

4. Place log #4 (W135-0687) firmly onto D1 and D2. Ensure log #3 and log #4 are touching.

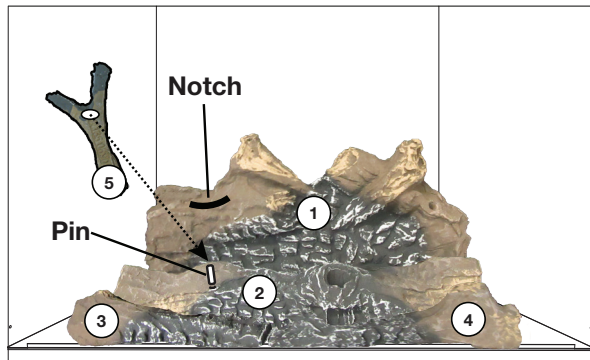

5. Place a pin in the hole located on the left side of log #2. Place log #5 (W135-0690) onto the pin, allowing the other end to rest in the notch of log #1.

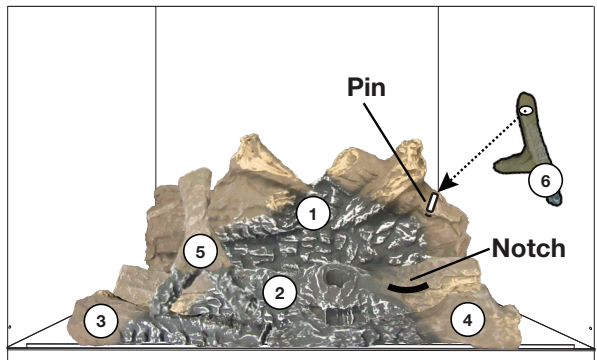

6. Place a pin in the hole located on the right side of log #1. Place log #6 (W135-0689) onto the pin, allowing the other end to rest in the notch of log #4.

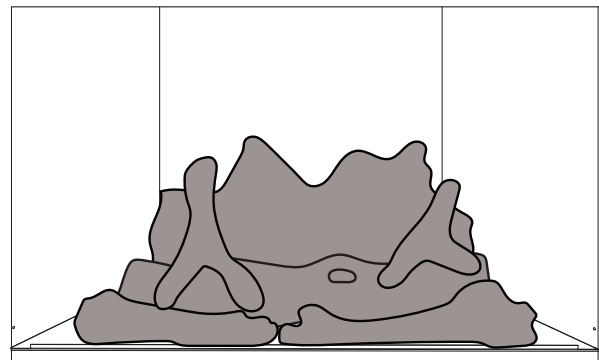
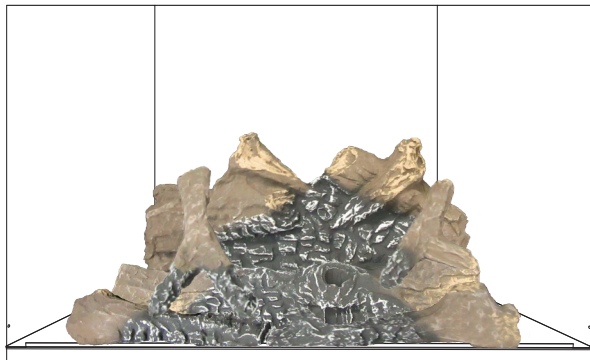

### 10.7 glowing embers

#### ! WARNING

- Completely blocking the burner ports can cause an incorrect flame pattern, carbon deposits and delayed ignition.

Tear the embers into pieces and loosely layer above the burner ports covering the burner area. Care should be taken to shred the embers into thin, small irregular pieces as only the exposed edges of the fibre hairs will glow.

**The ember material will only glow when exposed to direct flame; however, care should be taken to not block off the burner ports.**

Blocked burner ports can cause an incorrect flame pattern, carbon deposits and delayed ignition. **PHAZER™** logs glow when exposed to direct flame. Use only certified “glowing embers” and **PHAZER™** logs available from your local authorized dealer / distributor.

### 10.8 charcoal embers

#### ! WARNING

- Do not block or close off the burner ports. Blocked ports can cause an incorrect flame pattern, carbon deposits and delayed ignition.
- When supplied, charcoal embers, charcoal lumps and vermiculite are not to be placed on the burner.

Randomly place the charcoal embers along the front and sides of the log support in a realistic manner.

**Fine dust found in the bottom of the bag should not be used.**

**note:**

Charcoal embers are not to be placed on the burner.

### 10.9 logo placement

Remove the backing of the logo supplied and place, as illustrated.

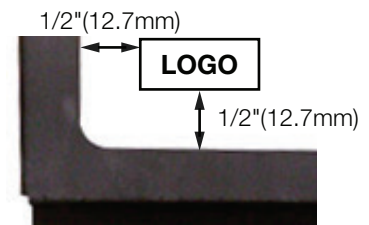

### 10.10 glass media placement

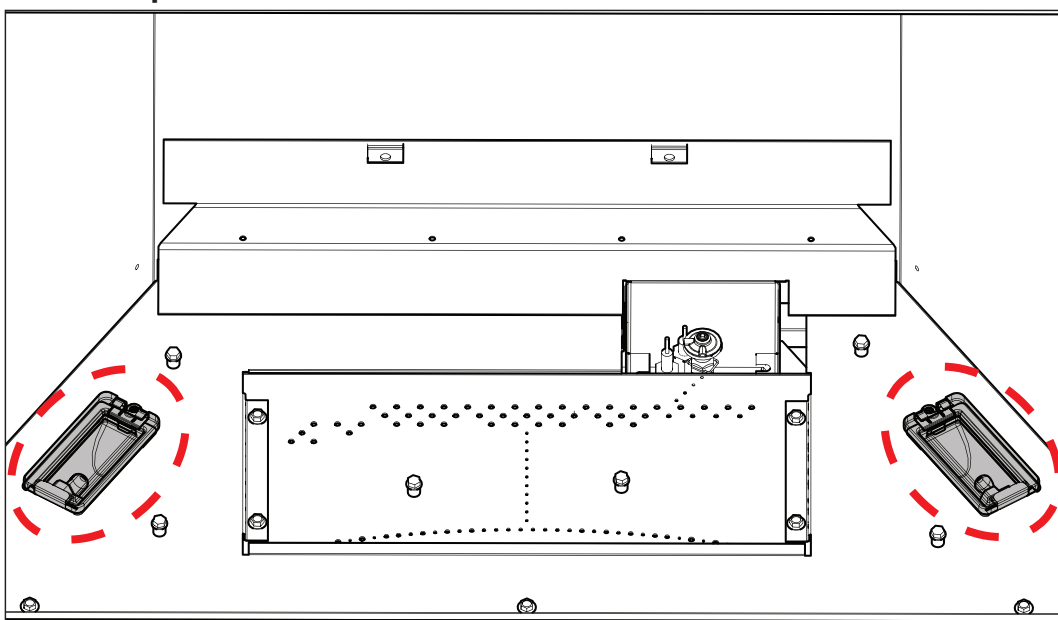

- Cover both lenses completely with clear glass (shaded area).
- Spread small amounts of amber glass over the clear glass to give the ember bed effect (shaded area).
- Some charcoal chips could be placed over the glass to dull the light especially when using porcelain panels.

# 11.0 adjustments

## 11.1 pilot burner adjustment

Adjust the pilot screw to provide properly sized flame. Turn in a clockwise direction to reduce the gas flow.

### Check Pressure Readings:

Inlet pressure can be checked by turning screw (A) counter-clockwise 2 or 3 turns and then placing pressure gauge tubing over the test point. Gauge should read as described on the chart below. Check pressure with main burner operating on "HI".

Outlet pressure can be checked the same as above using screw (B). Gauge should read as described on the chart below. Check pressure with main burner operating on "HI".

**After taking pressure readings, be sure to turn screws clockwise firmly to reseal. Do not overtorque.**

Leak test with a soap and water solution.

Prior to pilot adjustment, ensure that the pilot assembly has not been painted. If overspray or painting of the pilot assembly has occurred remove the paint from the pilot assembly, or replace. Fine emery cloth or a synthetic scrub pad (such as Scotch-Brite™) can be used to remove the paint from the pilot hood, electrode and flame sensor.

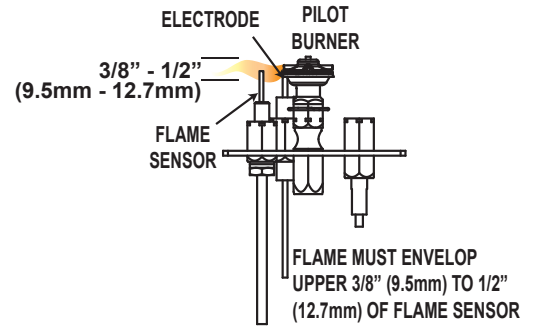

Pressure	Natural Gas (inches)	Natural Gas (millibars)	Propane (inches)	Propane (millibars)
Inlet	*7" (minimum 4.5")	17.4mb (minimum 11.2mb)	13" (minimum 11")	32.4mb (minimum 27.4mb)
Outlet	3.5"	8.7mb	10"	24.9mb

**\*Maximum inlet pressure not to exceed 13"**

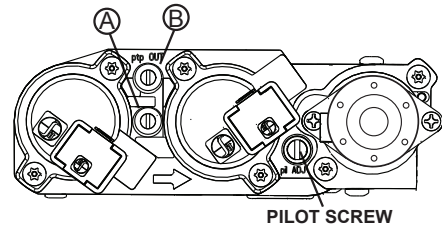

## 11.2 venturi adjustment

This appliance has an air shutter that has been factory set open according to the chart below:

Regardless of venturi orientation, closing the air shutter will cause a more yellow flame, but can lead to carbonization. Opening the air shutter will cause a more blue flame, but can cause flame lifting from the burner ports. The flame may not appear yellow immediately; allow 15 to 30 minutes for the final flame colour to be established.

**AIR SHUTTER ADJUSTMENT MUST ONLY BE DONE BY A QUALIFIED INSTALLER.**

### note:

It is important that the orifice is securely inserted into the venturi.

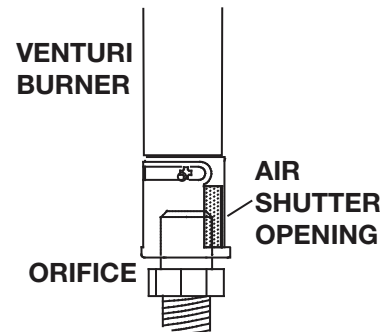

VENTURI ADJUSTMENT CHART		
FUEL	TOP	REAR
NG	1/16" (1.5mm)	1/8" (3.2mm)
P	1/4" (6.3mm)	3/8" (9.5mm)

### 11.3 flame characteristics

It's important to periodically perform a visual check of the pilot and burner flames. Compare them to the illustration provided. If any flames appear abnormal, call a service person.

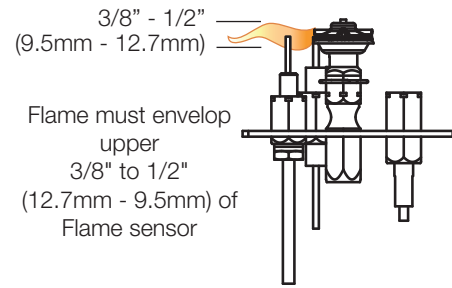
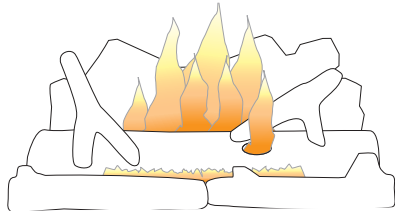

## 12.0 maintenance

### WARNING

- Turn off the gas and electrical power before servicing the appliance.
- Appliance may be hot. Do not service until appliance has cooled.
- Do not use abrasive cleaners on glass.
- Do not paint the pilot assembly.

This appliance and its venting system should be inspected before use and at least annually by a qualified service person. The following suggested checks should be performed by a qualified technician. The appliance area must be kept clear and free of combustible materials, gasoline, or other flammable vapors and liquids. The flow of combustion and ventilation air must not be obstructed.

#### note:

Caution: Label all wires prior to disconnection when servicing controls. Wiring errors can cause improper and dangerous operation. Verify proper operation after servicing.

1. In order to properly clean the burner and pilot assembly, remove the logs, rocks and/or glass to expose both assemblies.
2. Keep the control compartment, media, burner, air shutter opening and the area surrounding the appliance clean by vacuuming or brushing, at least once a year.
3. Check to see that all burner ports are burning. Clean out any of the ports which may not be burning or are not burning properly.
4. Check to see that the pilot flame is large enough to engulf the flame sensor and/or thermocouple / thermopile as well as it reaches the burner.
5. If your appliance is equipped with a safety barrier, cleaning may be necessary due to excessive lint / dust from carpeting, pets, etc. simply vacuum using the brush attachment.
6. If your appliance is equipped with relief doors, ensure the system performs effectively. Check that the gasket is not worn or damaged. Replace if necessary.
7. Replace the cleaned logs, rocks or glass. Failure to properly position the media may cause carboning which can be distributed in the surrounding living area, inside the firebox and on exterior surfaces surrounding vent termination.
8. Check to see that the main burner ignites completely on all ports when turned on. A 5 to 10 second total light-up period is satisfactory. If ignition takes longer, consult your local authorized dealer / distributor.
9. Visually inspect the appliance for carbon build up. Using a small whisk or brush, brush off the carbon and vacuum up or sweep into garbage.
10. **This step is not applicable for Vent Free appliances:** Check to see that the appliance is venting correctly. Ensure chimney system is safe and unobstructed. (If for any reason the vent air intake system is disassembled, re-install and re-seal per the instructions provided for the initial installation).

### 12.1 annual maintenance

### WARNING

- Annual maintenance should be performed by a qualified service technician
- The firebox becomes very hot during operation. Let the appliance cool completely or wear heat resistant gloves before conducting service.
- Never vacuum hot embers.
- Do not paint the pilot assembly

- This appliance will require maintenance which should be planned on an annual basis.
- Service should include cleaning, battery replacement, venting inspection and inspection of the burner, media, and firebox. Refer to the door removal section and remove the door as instructed.
- Carefully remove media if necessary (logs, glass, brick panels, etc.).
- Using a vacuum with soft brush attachment, gently remove any dirt, debris, or carbon build up from the logs, firebox, and burner. For glass media, follow the installation instructions for pre-cleaning.
- Gently remove any build-up on the pilot assembly including thermopile, thermocouple, flame sensor, and igniter (if equipped).

**note:**

Clean flame sensor using a fine emery cloth or a synthetic scrub pad (such as Scotch-Brite™) to remove any oxides. Clean the pilot assembly using a vacuum with a soft brush attachment. It is important that the pilot assembly is not painted.

- Inspect all accessible gaskets and replace as required.
- If equipped with a blower, access the blower and clean using a soft brush and vacuum.
- Re-assemble the various components in reverse order.
- Inspect the relief system. The appliance relieves through the main glass door or through the flaps on the firebox top. Ensure they open freely, and close sealed.
- Check the gas control valve pilot and Hi / Lo knobs move freely, if equipped. Replace if any stiffness in movement is experienced.
- Check for gas leaks on all gas connections up and downstream from the gas valve including pilot tube connections.

## 12.2 door glass replacement

### **WARNING**

- Do not use substitute materials.
- Glass may be hot. Do not touch glass until cooled.
- Care must be taken when removing and disposing of any broken door glass or damaged components. Be sure to vacuum up any broken glass from inside appliance before operation.
- Do not strike, slam, or scratch. Do not operate appliance with glass removed, cracked, broken, or scratched.

Replacement glass/frame assembly shall be replaced as a complete unit as supplied by the appliance manufacturer.

## 12.3 care of glass

### **WARNING**

- Do not clean glass when hot! Do not use abrasive cleaners to clean glass.

Buff lightly with a clean dry soft cloth to remove accumulated dust or fingerprints. Clean both sides of the glass after the first 4 hours of operation with an ammonia-free glass cleaner.

**note:**

Vinegar-based glass cleaners have demonstrated an ability to provide a clean, streak free glass surface.

Thereafter, clean as required. If the glass is not kept clean permanent discoloration and / or blemishes may result. Contact you local authorized dealer / distributor for complete cleaning instructions.

Razor blades, steel wool, or other metallic objects must not be used on both surfaces of the glass. Doing so can remove a thin layer of metal from the razor blades, steel wool, or other metallic objects that may then be deposited onto the coating. This can result in a discoloured stain or scratch-like mark. More importantly, this can scratch the glass surface, thereby reducing its strength.

Do not operate the appliance with broken glass, as leakage of flue gases may result.

Contact your local authorized dealer / distributor for complete cleaning instructions.

If the glass should ever crack or break while the fire is burning, do not open the door until the fire is out. Do not operate the appliance until the glass has been replaced. Contact you local authorized dealer / distributor for replacement parts. **DO NOT SUBSTITUTE MATERIALS.**

This appliance is factory equipped with 5mm ceramic glass. Use only replacement parts as supplied by the appliance manufacturer. **DO NOT SUBSTITUTE MATERIALS.**



# maintenance

## 12.4 night light replacement

Lights: To replace the halogen bulb in your appliance you must first remove the lens from the light housing. To remove the lens from the housing, remove the screw securing the housing in place (**Fig. 1**).

Snap the lens out of the housing (including the metal bracket) (**Fig. 2**). Do not touch the halogen bulb with your bare hands.

The oil from your fingertips will reduce the life of the bulb. With gloved hands gently pull the old bulb from the socket and replace with the new bulb. Reinstall the lens, by snapping it back into the housing and bend the tabs on the front of the housing back in to position.

(Fig. 1)

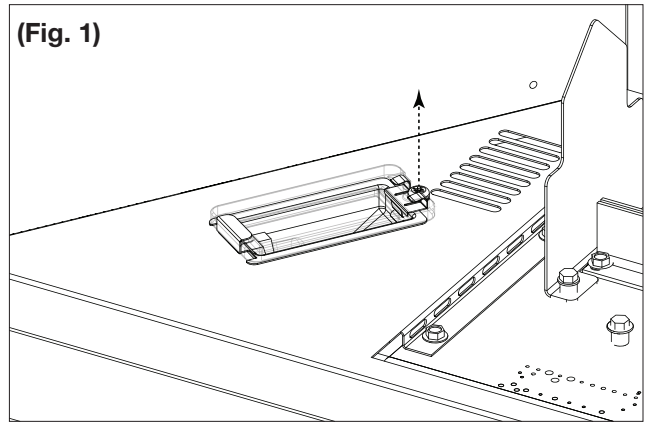

(Fig. 2)

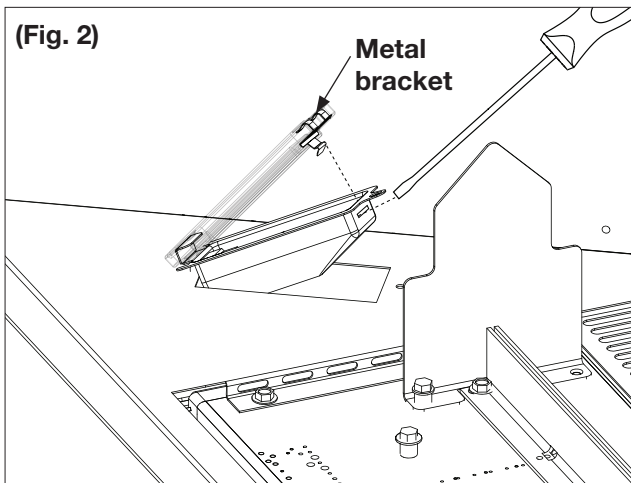

(Fig. 3)

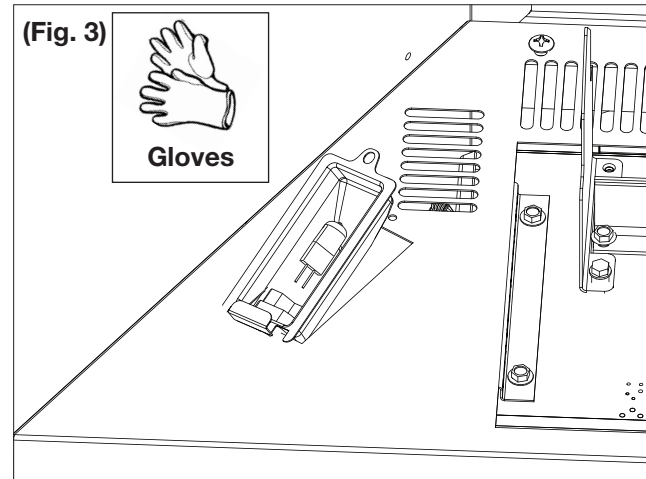

## 12.5 blower replacement

### ! WARNING

- Risk of fire and electrical shock!
- Turn off the gas and electrical power before servicing this appliance.
- Use only Wolf Steel approved optional accessories and replacement parts with this appliance. Using non-listed accessories (blowers, doors, louvres, trims, gas components, venting components, etc.) could result in a safety hazard and will void the warranty and certification.
- Ensure that the fan's power cord is not in contact with any surface of the appliance to prevent electrical shock or fire damage. Do not run the power cord beneath the appliance.
- The wire harness provided in the blower kit is a universal harness. When installed, ensure that any excess wire is contained, prevent it from making contact with moving or hot objects.

- Turn off the power to the appliance.
- Remove the safety barrier.
- Unplug the blower from the junction box.
- Lift the blower up from the slots.
- Disconnect the slip-on connectors at the motor of the blower.
- Replace the blower in assembly and reverse previous steps.
- Ensure that there are no cables touching the blower.

Drywall dust will penetrate into the blower bearings, causing irreparable damage. Care must be taken to prevent drywall dust from coming into contact with the blower or its compartment. Any damage resulting from this condition is not covered by the warranty policy.

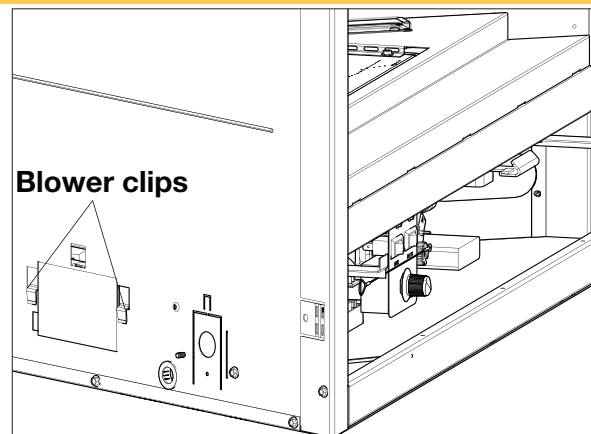



 **WARNING**

- Failure to position the parts in accordance with this manual or failure to use only parts specifically approved with this appliance may result in property damage or personal injury.
- \*\*This is a fast acting thermocouple. It is an integral safety component. Replace only with a fast acting supplied by Wolf Steel Ltd.

Contact your dealer for questions concerning prices and policies on replacement parts. Normally, all parts can be ordered through your Authorized dealer / distributor.

**For warranty replacement parts, a photocopy of the original invoice will be required to honour the claim.**

When ordering replacement parts always give the following information:

- Model & Serial Number of appliance
- Installation date of appliance
- Part number
- Description of part
- Finish

**Parts, part numbers, and availability are subject to change without notice.**

**Parts identified as stocked will be delivered within 2 to 5 business days for most delivery destinations.**

**Parts not identified as stocked will be delivered within a 2 to 4 week period, for most cases.**

**Parts identified as 'SO' are special order and can take up to 90 days for delivery**

13.1 overview

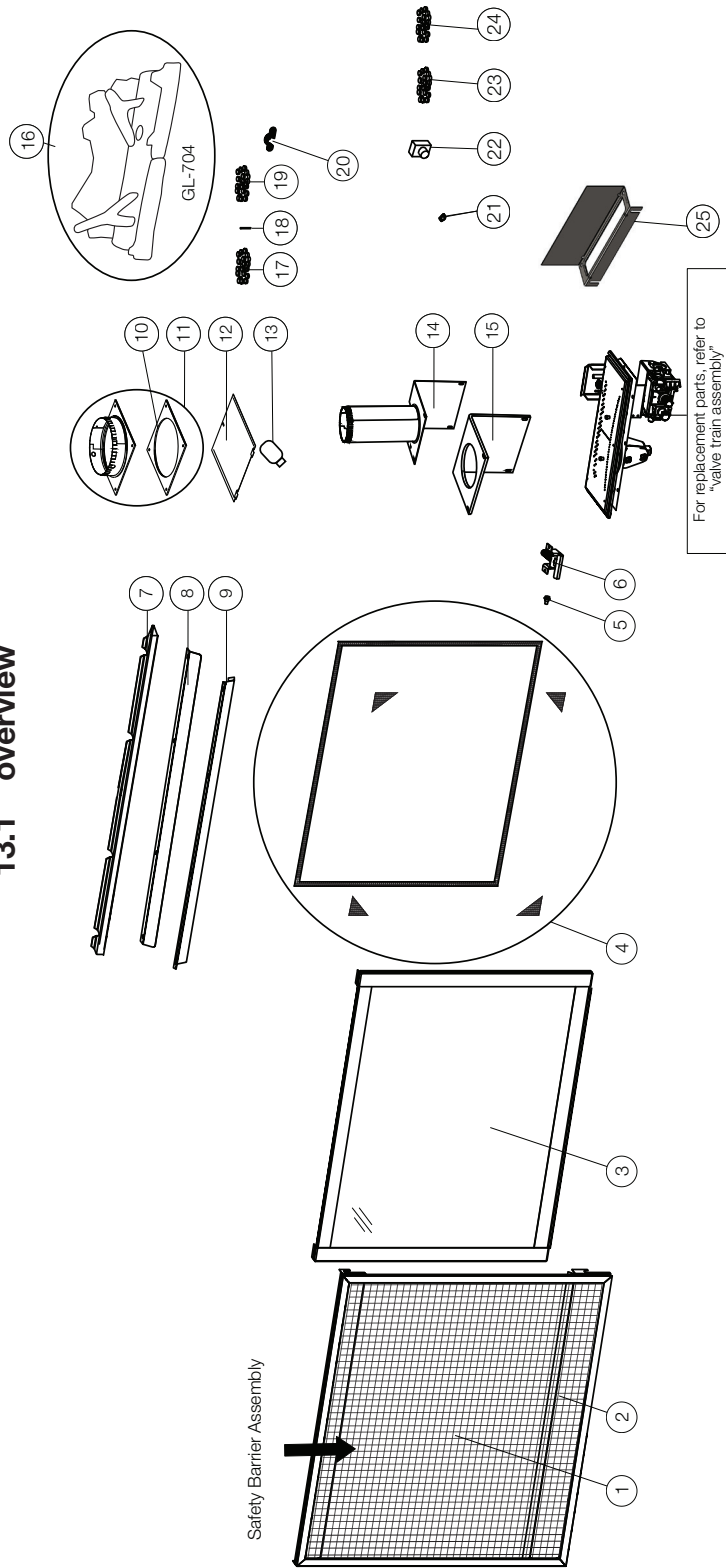

Items may not appear exactly as illustrated.

Ref. No.	Part Number	Description	Stocked
1	W565-0242-SER	Safety Screen	Yes
2	W010-4006-SER	Safety Barrier Assembly	Yes
3	W010-3402-SER	Complete Door Assembly	Yes
4	W562-0009	Door Gasket Assembly	Yes
5	W570-0135	Shoulder Screws	Yes
6	W010-3554	Door Latch	
7	W715-1040-SER	Top Finishing Trim	
8	W335-0063-SER	Hood	
9	W018-0158-SER	Front Baffle	
10	W290-0054	7" Flange Gasket	Yes
11	W010-3489-SER	7" Air Collar Assembly (C/W Gasket)	
12	W500-0837	Vent Cover Plate	
13	RP4	4" Restrictor Plate	
14	W010-3490-SER	Exhaust Collar Assembly	
15	W290-0282	Exhaust Bracket Gasket	
16	GL-704	Log set	
17	W361-0016	Glowing Embers	Yes
18	W485-0051	Log Locating Pin (X2)	
19	W550-0001	Charcoal Embers	Yes
20	W385-2010	Napoleon Logo	Yes
21	W690-0002	Thermodisc	
22	W660-0019	Variable speed switch	
23	W300-0356	Amber glass	
24	W300-0355	Clear reflective glass	
25	W200-0563-SER	Exhaust opening cover	
26*	W387-0021	Light bulb	
27*	F60	Thermostatic remote	
28*	W405-0097	Light assembly	
29*	W062-0077-SER	Blower	
30*	W750-0159	Light assembly power cord	
31*	W750-0050	Blower wire harness	
32*	W750-0530	2-Way ember bed/light wire	
33*	W750-0531	Ember bed jumper wire	

\* Parts not illustrated.

13.2 valve train assembly

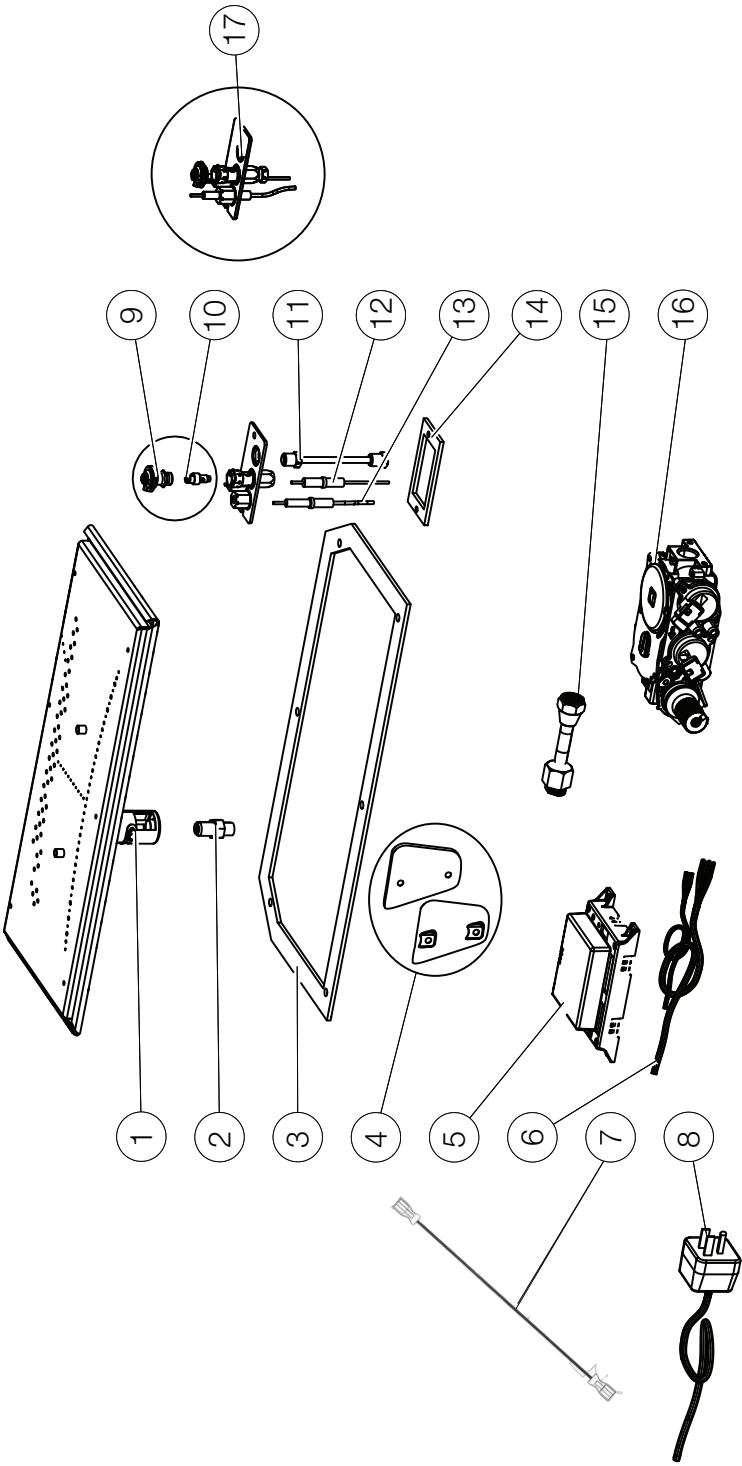

Items may not appear exactly as illustrated.

Ref. No.	Part Number	Description	Stocked	Ref. No.	Part Number	Description	Stocked
1	W100-0191-SER	Burner Assembly	Yes	10	W455-0068	Pilot Orifice #35 (P)	Yes
2	W456-0042	Burner Orifice #42 (NG)	Yes	11	W720-0062	Pilot Tube (w/ Fittings)	Yes
2	W456-0053	Burner Orifice #53 (P)	Yes	12	W240-0013	Electrode (w/ Wire)	Yes
3	W290-0248	Valve Train Gasket	Yes	13	W245-0025	Thermosensor	Yes
4	W500-0276-SER	Venturi Cover Assembly		14	W290-0029	Pilot gasket	
5	W190-0195	Control board	Yes	15	W432-0078	Manifold Flex Pipe	Yes
6	W750-0497	Wire harness (Control)	Yes	16	W725-0062	Valve (NG)	Yes
7	W750-0493	PFO Ground Wire	Yes	16	W725-0063	Valve (P)	Yes
8	W750-0506	Power cord		17	W010-2763	Pilot Assembly (NG)	Yes
9	W335-0039	Pilot hood	Yes	17	W010-2808	Pilot Assembly (P)	Yes
10	W455-0070	Pilot Orifice #62 (NG)	Yes				

## ! WARNING

- Always light the pilot whether for the first time or if the gas supply has run out, with the glass door open or removed.
- Turn off gas and electrical power before servicing the appliance.
- Appliance may be hot. Do not service until appliance has cooled.
- Do not use abrasive cleaners

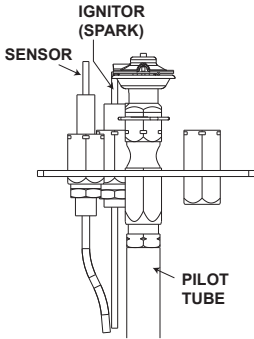
symptom	problem	test solution															
Main burner flame is a blue, lazy, transparent flame. (This is not applicable in outdoor appliances)	Blockage in vent.  Incorrect installation.	- Remove blockage. In really cold conditions, ice buildup may occur on the terminal and should be removed as required. (To minimize this from reoccurring, the vent lengths that pass through unheated spaces (attics, garages, crawl spaces) should be wrapped with an insulated mylar sleeve).  - Refer to "venting" section to ensure correct installation.															
Flames are consistently too large or too small. Carboning occurs.	Appliance is over-fired or under-fired.	- <b>Check pressure readings:</b> Inlet pressure can be checked by turning screw (A) counter-clockwise 2 or 3 turns and then placing pressure gauge tubing over the test point. Gauge should read as described on the chart below. Check that main burner is operating on 'HI'. Outlet pressure can be checked the same as above using screw (B). Gauge should read as described on the chart below. Check that main burner is operating on 'HI'. <b>After taking pressure readings, be sure to turn screws clockwise firmly to reseal. DO NOT OVER TORQUE.</b> Leak test with a soap and water solution.															
																	
<table border="1"> <thead> <tr> <th>Pressure</th> <th>Natural Gas (inches)</th> <th>Natural Gas (millibars)</th> <th>Propane (inches)</th> <th>Propane (millibars)</th> </tr> </thead> <tbody> <tr> <td>Inlet</td> <td>*7" (minimum 4.5")</td> <td>17.4mb (minimum 11.2mb)</td> <td>13" (minimum 11")</td> <td>32.4mb (minimum 27.4mb)</td> </tr> <tr> <td>Outlet</td> <td>3.5"</td> <td>8.7mb</td> <td>10"</td> <td>24.9mb</td> </tr> </tbody> </table> <p style="text-align: right;"><b>*Maximum inlet pressure not to exceed 13" w.c.</b></p>			Pressure	Natural Gas (inches)	Natural Gas (millibars)	Propane (inches)	Propane (millibars)	Inlet	*7" (minimum 4.5")	17.4mb (minimum 11.2mb)	13" (minimum 11")	32.4mb (minimum 27.4mb)	Outlet	3.5"	8.7mb	10"	24.9mb
Pressure	Natural Gas (inches)	Natural Gas (millibars)	Propane (inches)	Propane (millibars)													
Inlet	*7" (minimum 4.5")	17.4mb (minimum 11.2mb)	13" (minimum 11")	32.4mb (minimum 27.4mb)													
Outlet	3.5"	8.7mb	10"	24.9mb													
	Air shutter improperly adjusted.	- Return air shutter to specified opening, see " <b>venturi adjustments</b> " section in the installation manual.															
Carbon is being deposited on glass, logs, rocks, media, or combustion chamber surfaces.	Air shutter is blocked.  Flame is impinging on the glass, logs, rocks, media or combustion chamber.	- Ensure air shutter opening is free of lint or other obstructions.  - Ensure the media is positioned correctly in the appliance. - Open air shutter to increase the primary air. - Check the input rate: check the manifold pressure and orifice size as specified by the rating plate. - Ensure door gaskets are not broken or missing and the seal is tight. - Ensure vent liners are free of holes and well sealed at all joints. - Check that minimum rise per foot (meters) has been adhered to for any horizontal venting.															
White / grey film forms.	Sulphur from fuel is being deposited on glass, logs, or combustion chamber surfaces.	- Clean the glass with a recommended gas fireplace glass cleaner. <b>DO NOT CLEAN GLASS WHEN HOT.</b> - If deposits are not cleaned off regularly, the glass may become permanently marked.															
Exhaust fumes smelled in room, headaches. (This is not applicable in outdoor appliances).	Appliance is spilling. (This is not applicable in outdoor appliances).	- Check door seal. - Check for exhaust damage. - Check that venting is installed correctly. - Room is in negative pressure; increase fresh air supply.															

symptom	problem	test solution
Pilot will not light. Makes noise with no spark at pilot burner.	Wiring: short, loose, or damaged connections (poor flame rectification).	<ul style="list-style-type: none"> <li>- Verify the thermocouple/sensor is clean and the wiring is undamaged.</li> <li>- Verify the interrupter block is not damaged or too tight. Verify connections from pilot assembly are tight; also verify the connections are not grounding out to any metal. (Remember, the flame carries the rectification current, not the gas. If flame lifts from pilot hood, the circuit is broken. A wrong orifice or too high of an inlet pressure can cause the pilot flame to lift)*. The sensor rod may need cleaning.</li> </ul>
	No signal from remote with no pilot ignition.	<ul style="list-style-type: none"> <li>- Reprogram receiver code.</li> <li>- Replace receiver.</li> </ul>
	Poor grounding.	<ul style="list-style-type: none"> <li>- Verify the valve / pilot assembly are properly grounded</li> </ul>
	Improper switch wiring.	<ul style="list-style-type: none"> <li>- Troubleshoot the system with the simplest <b>on/off</b> switch.</li> </ul>
	Dirty, painted, or damaged pilot and/or dirty sensor rod.	<ul style="list-style-type: none"> <li>- Clean sensor rod with a green Scotch-Brite™ pad to remove any contamination that may have accumulated. Verify continuity with multimeter with ohms set at the lowest range.</li> </ul>
Pilot sparks but will not light.	Gas supply.	<ul style="list-style-type: none"> <li>- Verify that the incoming gas line ball valve is “open”.</li> <li>- Verify that the inlet pressure reading is within acceptable limits, inlet pressures must not exceed 13” W.C. (32.4mb).</li> </ul>
	Out of propane gas.	<ul style="list-style-type: none"> <li>- Fill the tank.</li> </ul>
	Pilot supply line may contain air.	<ul style="list-style-type: none"> <li>- Repeat ignition process several times or purge the pilot supply line.</li> </ul>
	Incorrect wiring / grounding.	<ul style="list-style-type: none"> <li>- Ensure correct polarity of wiring of thermocouple (if equipped).</li> <li>- Verify pilot assembly / valve are properly grounded.</li> </ul>
	Receiver (if equipped).	<ul style="list-style-type: none"> <li>- Reset program: hold reset button on receiver and wait for 2 beeps. Release after second beep. Press small flame button on remote within 20 seconds, you will hear an additional beep (this signals a successful reset).</li> <li>- Replace receiver.</li> </ul>
	Valve.	<ul style="list-style-type: none"> <li>- Check valve and replace if necessary (Do not to overtighten thermocouple).</li> </ul>
Burner continues to spark and pilot lights but main burner does not light.	Short or loose connection in sensor rod.	<ul style="list-style-type: none"> <li>- Verify all connections. Verify the connections from the pilot assembly are tight. Also, verify these connections are not grounding out to any metal.</li> </ul>
	Dirty, painted, or damaged pilot assembly components.	<ul style="list-style-type: none"> <li>- Clean using a green Scotch-Brite™ pad to remove any contamination that may have accumulated on the sensor rod, pilot hood, ignitor, or flame sensor. Verify continuity with multimeter with ohms set at the lowest range.</li> </ul>
Remote wall switch is in “off” position; burner comes on.	Wall switch mounted upside down.	<ul style="list-style-type: none"> <li>- Reverse.</li> </ul>
	Remote wall switch and/or wire is grounding.	<ul style="list-style-type: none"> <li>- Replace.</li> <li>- Check for ground (short); repair ground or replace wire.</li> </ul>
	Faulty wire	<ul style="list-style-type: none"> <li>- Replace.</li> </ul>
Remote and / or receiver is not functioning properly.	Remote controls lights but no spark or flame. (Remote is locked out).	<ul style="list-style-type: none"> <li>- Reset by turning power source off then on.</li> </ul> <div style="border: 1px solid black; padding: 5px; margin-top: 5px;"> <p><b>note:</b> If back up batteries are installed, they must also be removed to re-program</p> </div>
	Receiver or remote has low battery.	<ul style="list-style-type: none"> <li>- Replace batteries.</li> </ul>
	Appliance functions but does not respond to receiver / remote	<ul style="list-style-type: none"> <li>- Ensure appliance is being operated by the same device that turned it on. Remote controls function if appliance was turned on by remote. Receiver controls function if appliance was turned on by receiver.</li> </ul>
	Error with synchronizing.	<ul style="list-style-type: none"> <li>- Reset receiver and remote.</li> </ul>
	Remote too far away from receiver.	<ul style="list-style-type: none"> <li>- Refer to “wiring diagram” section.</li> </ul>
	Wire connector pins are bent.	<ul style="list-style-type: none"> <li>- Straighten pins.</li> </ul>
	Valve wiring is damaged.	<ul style="list-style-type: none"> <li>- Replace valve.</li> </ul>