

INSTALLER: LEAVE THIS MANUAL WITH THE APPLIANCE.
CONSUMER: RETAIN THIS MANUAL FOR FUTURE REFERENCE.
NEVER LEAVE CHILDREN OR OTHER AT RISK INDIVIDUALS ALONE WITH THE APPLIANCE.



INSTALLATION AND OPERATING INSTRUCTIONS

EN

FR
PG
13

NEFCP24-0116BW/W & NEFCP24-0116E ELECTRIC FIREPLACE MANTEL

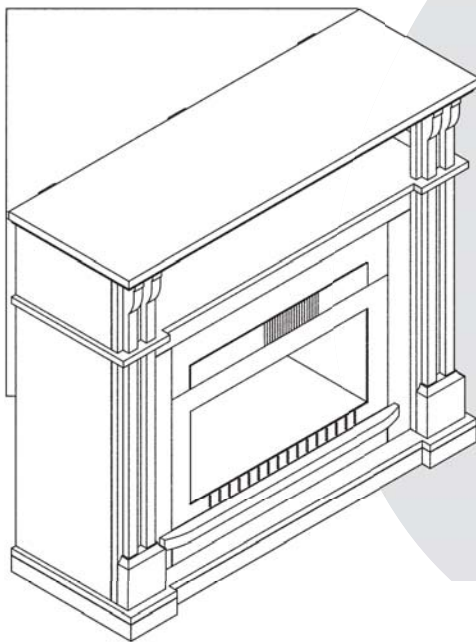

NEFCP24-0116BW/W

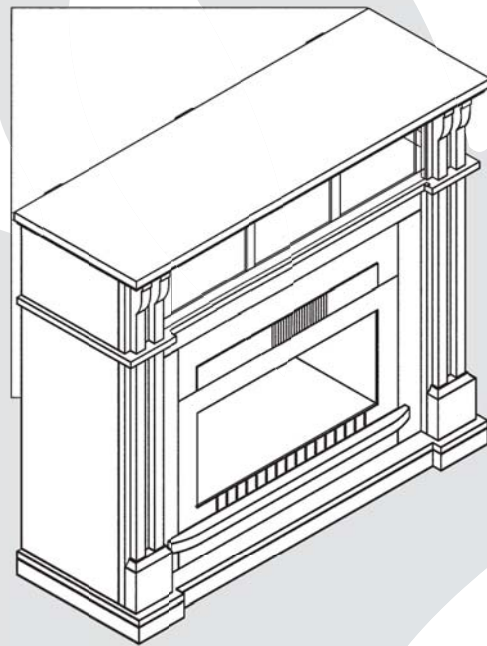

NEFCP24-0116E



Wolf Steel Ltd., 24 Napoleon Rd., Barrie, ON, L4M 0G8 Canada /
103 Miller Drive, Crittenden, Kentucky, USA, 41030
Phone (705)721-1212 • Fax (705)720-9081 • www.napoleonfireplaces.com • hearth@napoleonproducts.com

\$10.00

1.45C

W415-1668 / 07.19.16

TABLE OF CONTENTS

1.0	GENERAL INFORMATION	2
2.0	OVERVIEW	2
2.1	MEDIA CONSOLE COMPONENTS LIST	2
2.2	HARDWARE LIST	3
2.3	ANCHOR KIT	3
3.0	ASSEMBLY	6
3.1	ANCHORING THE MANTEL	7
3.2	APPLIANCE INSTALLATION	8
3.3	CARE AND MAINTENANCE	8
4.0	WARRANTY	9
5.0	NOTES	10

NOTE: Changes, other than editorial, are denoted by a vertical line in the margin.

1.0 GENERAL INFORMATION

This mantel assembly is approved for use with electric appliance only. It is not approved for use as a stand alone product or in conjunction with any other appliance. It is necessary to anchor this mantel to a wall with the hardware kit provided for your safety.

2.0 OVERVIEW

2.1 MEDIA CONSOLE COMPONENTS LIST

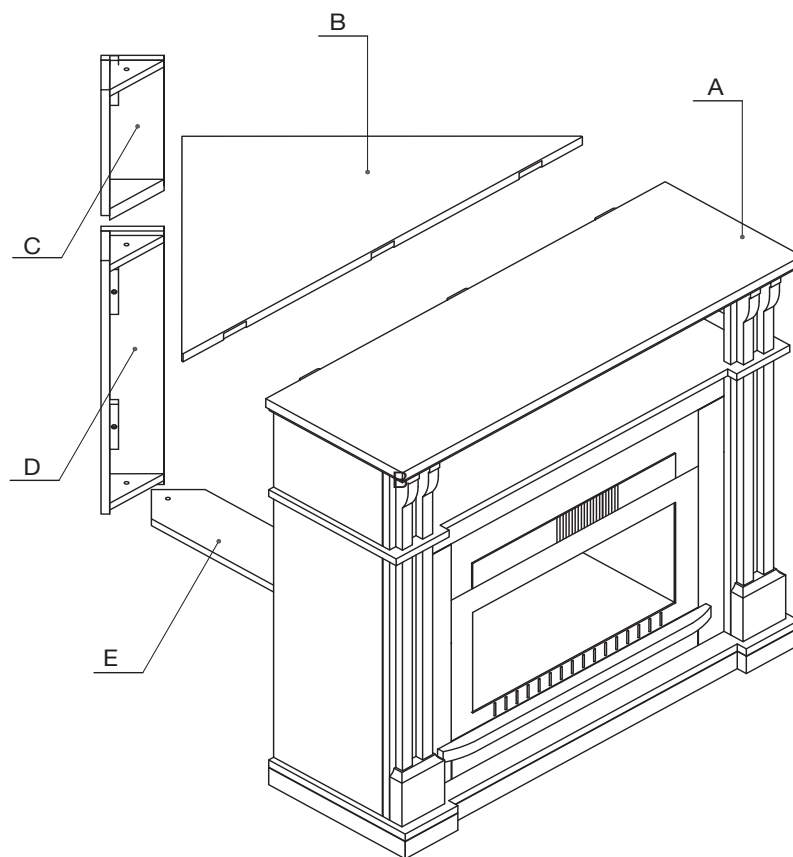

REF.	PART NO.	DESCRIPTION	QTY
A	W431-0066	MANTEL, MAIN BODY	1
B	W475-1342	TOP TRIANGLE	1
C	W475-1343	REAR TOP POST	1
D	W475-1344	REAR BOTTOM POST	1
E	W475-1345	BOTTOM CONNECT	1
F1	W370-0103	HARDWARE KIT (NEFCP24-0116BW)	1
F2	W370-0104	HARDWARE KIT (NEFCP24-0116W)	1
F3	W370-0105	HARDWARE KIT (NEFCP24-0116E)	1

2.2 HARDWARE LIST

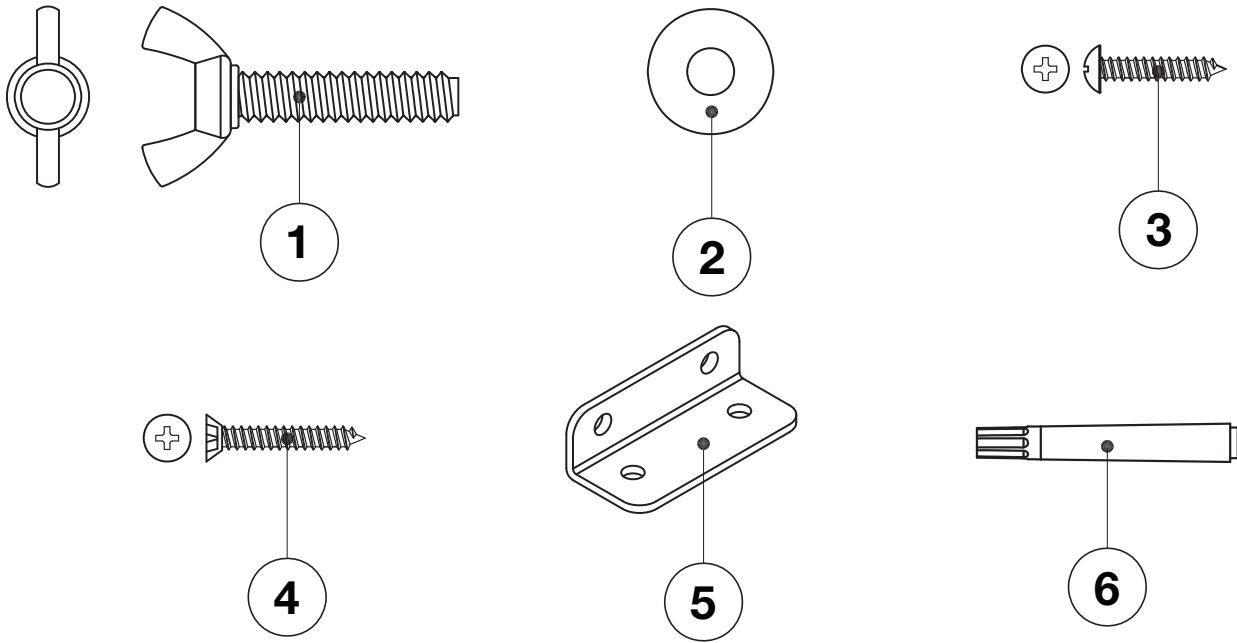

PART	DESCRIPTION	QTY
1	BOLT	5
2	FLAT WASHER	5
3	ROUND HEAD SCREW	6
4	FLAT HEAD SCREW	6
5	CORNER	3
6	TOUCH-UP PEN	1
7	ANCHOR KIT (SECTION 2.3)	1

2.3 ANCHOR KIT

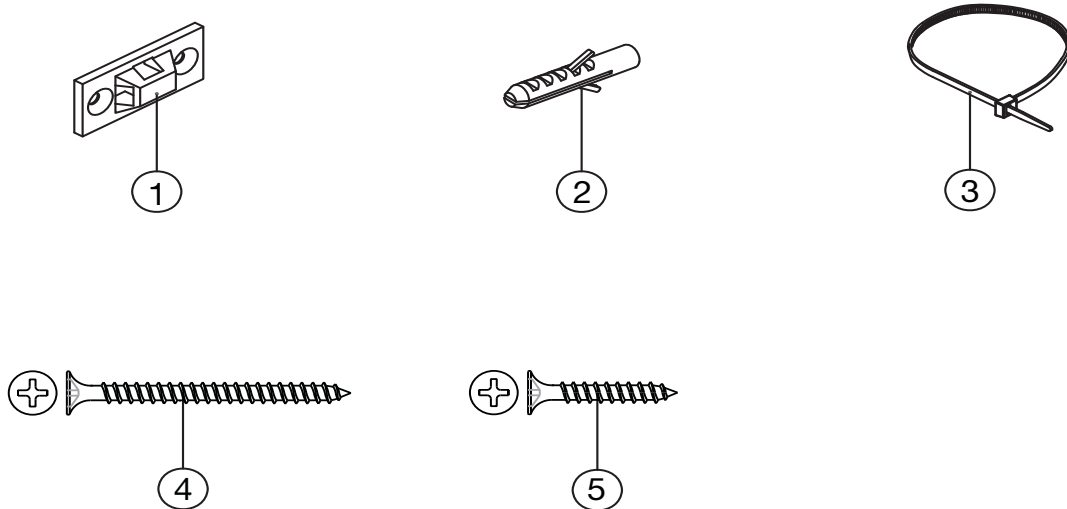

PART	DESCRIPTION	QTY
1	MOUNTING BRACKET	2
2	ANCHOR	2
3	NYLON STRAP	1
4	FLAT HEAD SCREW	2
5	FLAT HEAD SCREW	2

3.0 ASSEMBLY

1

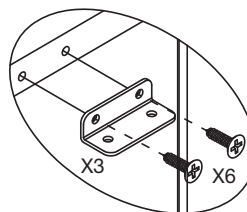
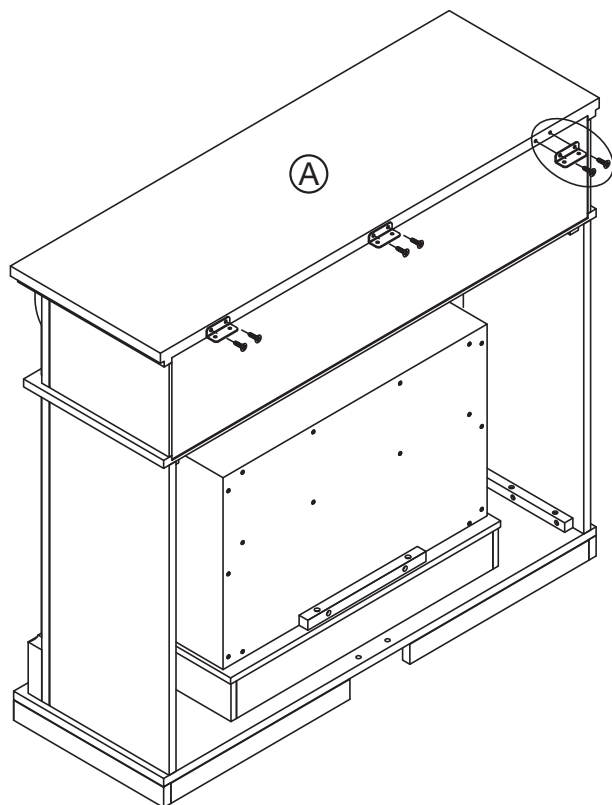

FLAT HEAD SCREWS
(PART #4)

CORNER
(PART #5)

2

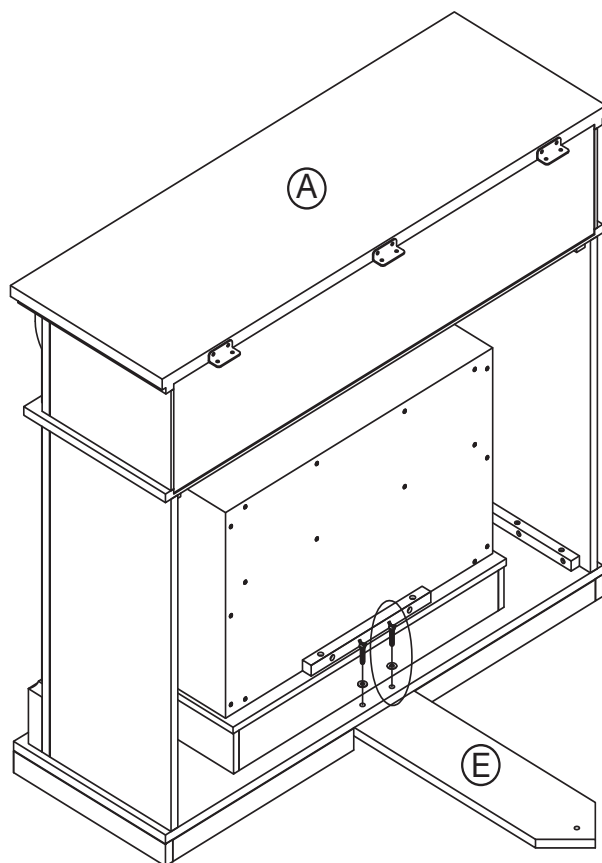

BOLT
(PART #1)

FLAT WASHER
(PART #2)

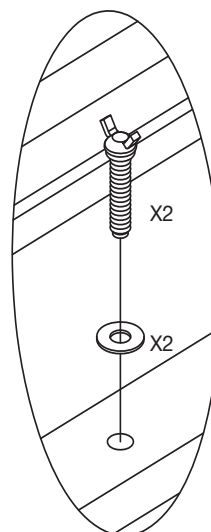

3

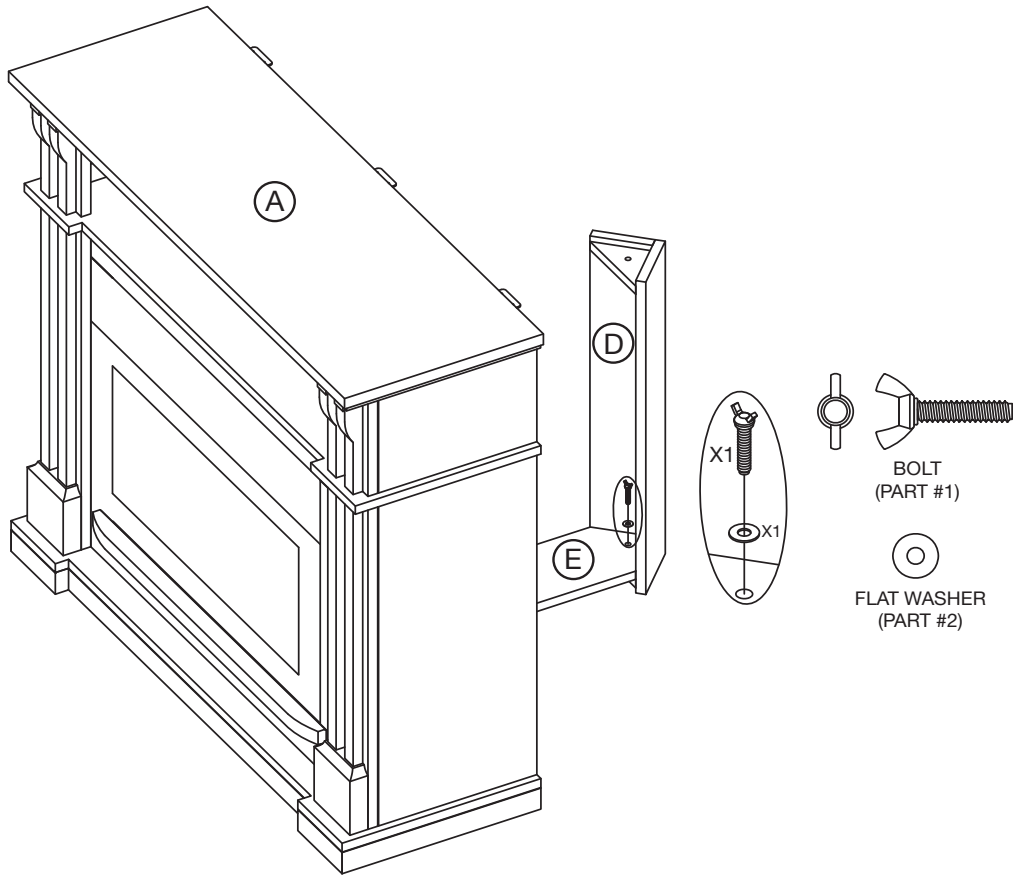

4

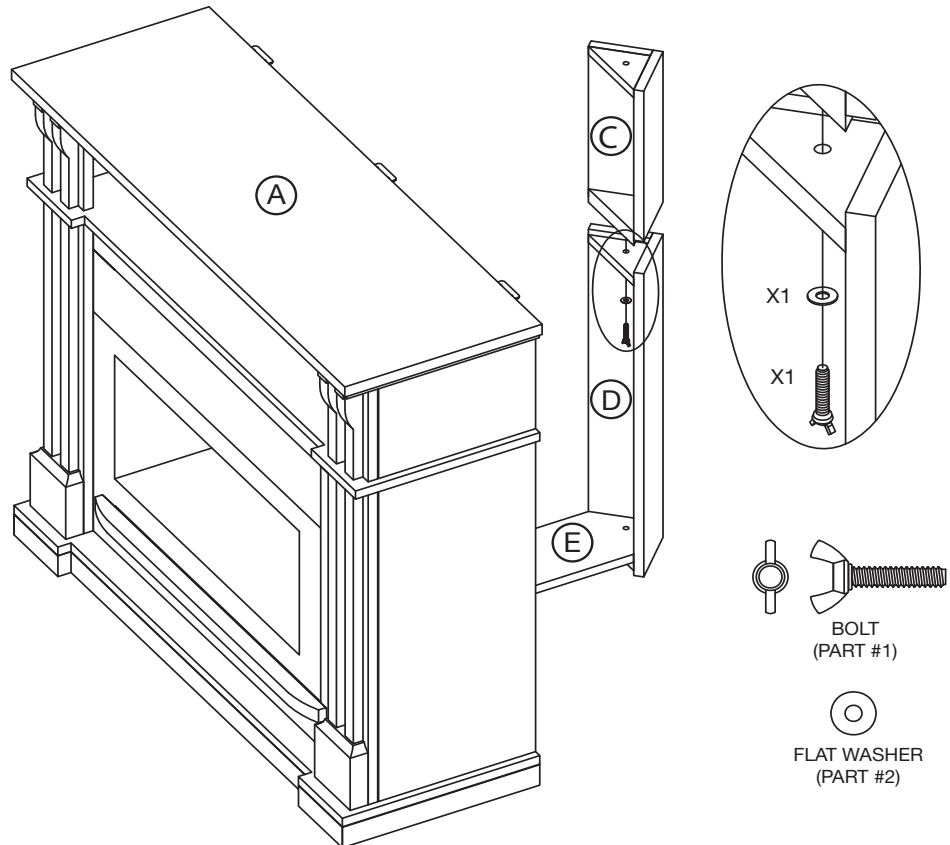

5

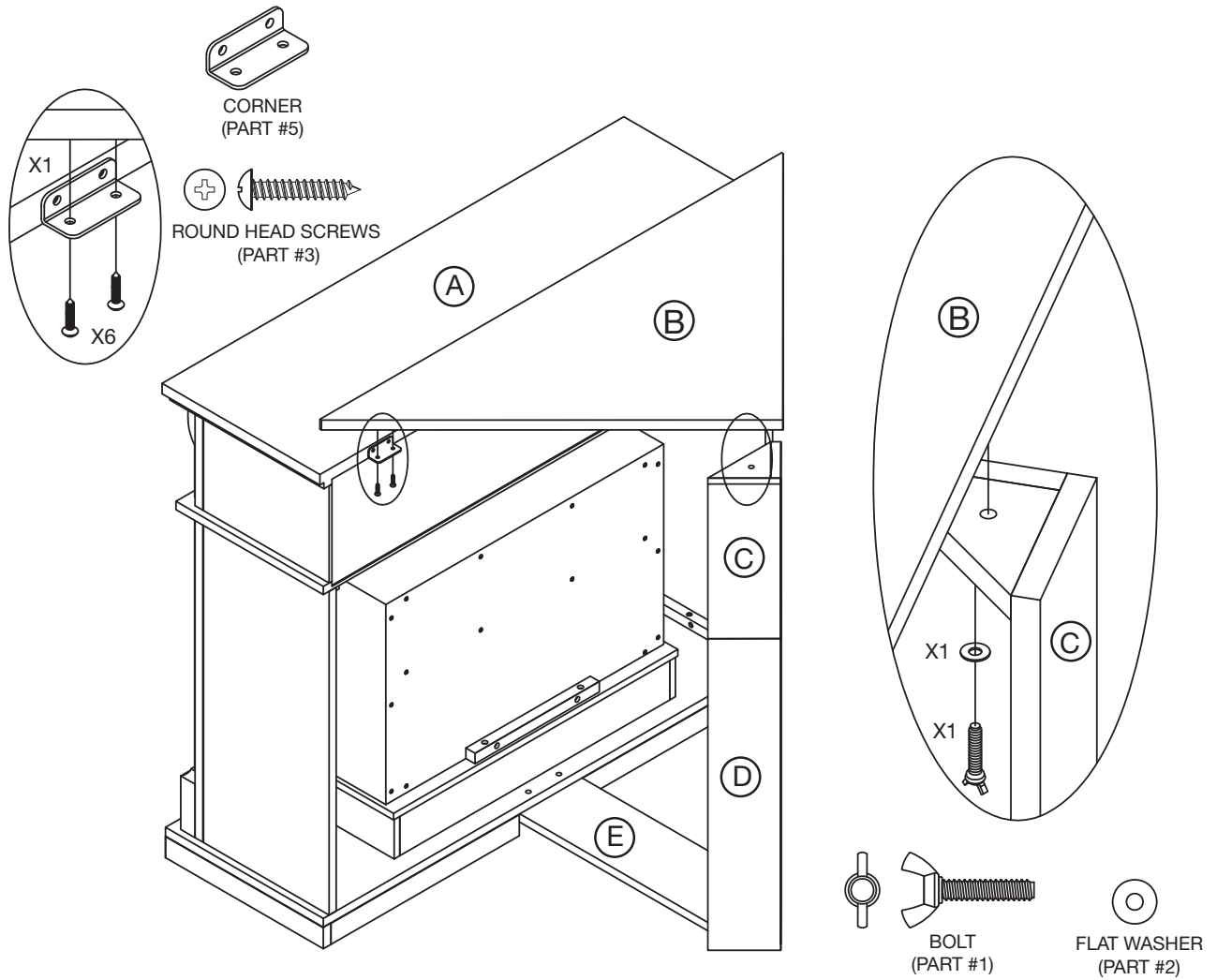

3.1 ANCHORING THE MANTEL

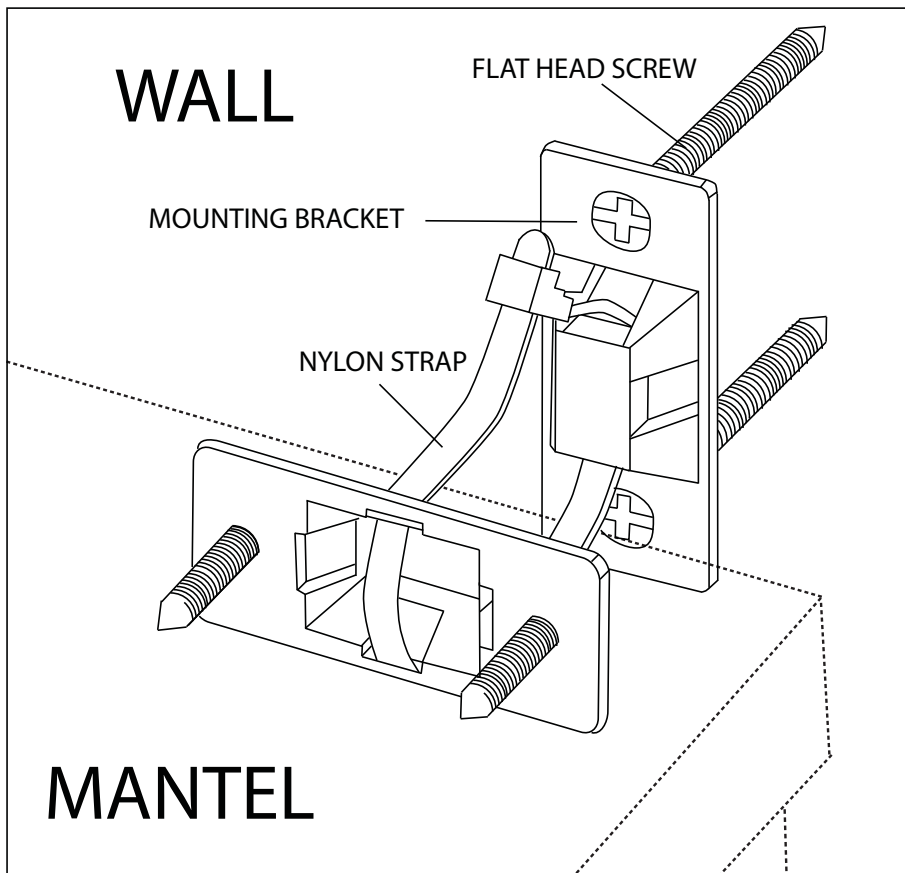
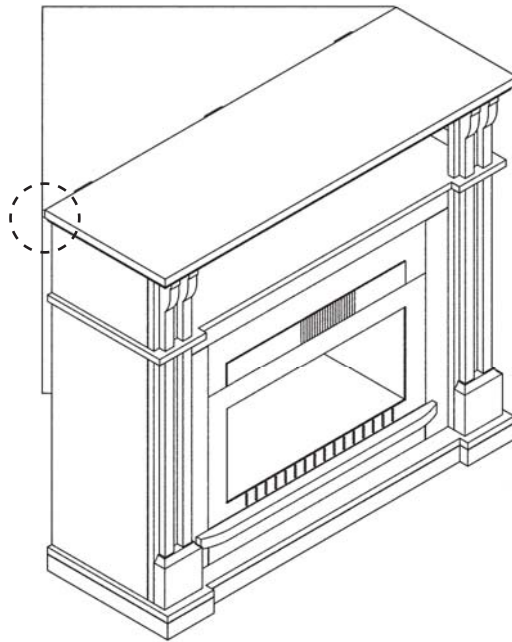

3.2 APPLIANCE INSTALLATION

! WARNING

DO NOT SLIDE APPLIANCE; MANTEL OR OTHER PAINTED SURFACES MAY SCRATCH.

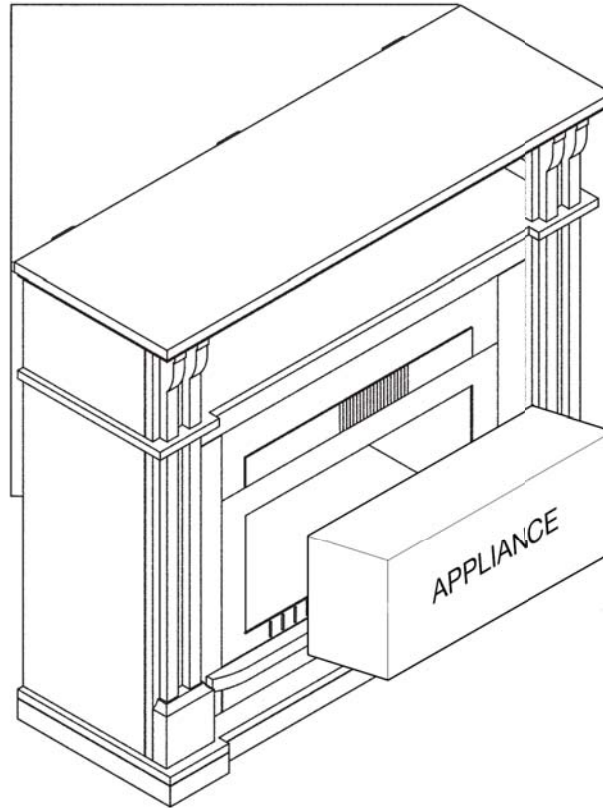

3.3 CARE AND MAINTENANCE

! WARNING

**DO NOT USE ABRASIVE OR CHEMICAL CLEANERS;
DISCOLOURING OR DAMAGE TO FINISH MAY RESULT.**

Clean mantel with a non-abrasive cloth. Clean as often as necessary.

NOTE: Excessive sun exposure may cause discolouring or fading of mantel finish.

4.0 WARRANTY

NAPOLEON products are designed with superior components and materials. The complete wood furniture is thoroughly inspected before packing to ensure that you, the customer, receive the quality product that you expect from NAPOLEON.

NAPOLEON WOOD FURNITURE LIMITED WARRANTY

NAPOLEON will provide replacement parts free of charge during the first year of limited warranty.
Any labour related to warranty repair is not covered.
* Construction of models vary. Warranty applies only to components included with your wood furniture.

CONDITIONS AND LIMITATIONS

Your wood furniture is constructed of the finest quality grade materials. However, because the nature of wood, you may notice variations in grain consistency; this is normal and will add to the uniqueness of your furniture.

NAPOLEON warrants its products against manufacturing defects to the original purchaser only. Registering your warranty is not necessary. Simply provide your proof of purchase along with the model and serial number to make a warranty claim. NAPOLEON reserves the right to have its representative inspect any product or part thereof prior to honouring any warranty claim. Provided that the purchase was made through an authorized NAPOLEON dealer your wood furniture is subject to the following conditions and limitations:

Warranty coverage begins on the date of original installation.

This factory warranty is non-transferable and may not be extended whatsoever by any of our representatives.

Installation must be done in accordance with the installation instructions included with the product and all local and national building and fire codes.

This limited warranty does not cover damages caused by misuse, lack of maintenance, accident, alterations, abuse or neglect and parts installed from other manufacturers will nullify this warranty.

This limited warranty further does not cover any scratches, dents, discoloring caused by sun exposure, abrasive and chemical cleaners nor chipping.

In the first year only, this warranty extends to the repair or replacement of warranted parts which are defective in material or workmanship provided that the product has been assembled and operated in accordance with the operation instructions and under normal conditions.

NAPOLEON will not be responsible for installation, labour or any other expenses related to the reinstallation of a warranted part and such expenses are not covered by this warranty. Notwithstanding any provisions contained in the Limited Warranty, NAPOLEON's responsibility under this warranty is defined as above and it shall not in any event extend to any incidental, consequential or indirect damages.

This warranty defines the obligations and liability of NAPOLEON with respect to the NAPOLEON wood furniture and any other warranties expressed or implied with respect to this product, its components or accessories are excluded.

NAPOLEON neither assumes, nor authorizes any third party to assume, on its behalf, any other liabilities with respect to the sale of this product.

Any damages to the furniture, glass or other component due to water, weather damage, cracking, long periods of dampness, condensation, damaging chemicals or cleaners will not be the responsibility of NAPOLEON.

The bill of sale or copy will be required together with a serial number and a model number when making any warranty claims from your authorized dealer. The warranty registration card must be returned within fourteen days to register the warranty.

NAPOLEON reserves the right to have its representative inspect any product or part thereof prior to honouring any warranty claim.

All parts replaced under the Limited Warranty Policy are subject to a single claim.

All parts replaced under the warranty will be covered for a period of 90 days from the date of their installation.

The manufacturer may require that defective parts or products be returned or that digital pictures be provided to support the claim. Returned products are to be shipped prepaid to the manufacturer for investigation. If a product is found with a defect, the manufacturer will repair or replace such defect.

Before shipping defective components, your dealer must obtain an authorization number. Any merchandise shipped without authorization will be refused and returned to sender.

Shipping costs are not covered under this warranty.

Additional service fees may apply if you are seeking warranty service from a dealer.

ALL SPECIFICATIONS AND DESIGNS ARE SUBJECT TO CHANGE WITHOUT PRIOR NOTICE DUE TO ON-GOING PRODUCT IMPROVEMENTS.
NAPOLEON IS A REGISTERED TRADEMARK OF WOLF STEEL LTD.

Other Napoleon Products



Fireplace Inserts • Charcoal Grills • Gas Fireplaces • Waterfalls • Wood Stoves
Heating & Cooling • Electric Fireplaces • Outdoor Fireplaces • Gas Grills



24 Napoleon Road, Barrie, Ontario, Canada L4M 0G8
214 Bayview Drive, Barrie, Ontario, Canada L4N 4Y8
103 Miller Drive, Crittenden, Kentucky, USA 41030
7200 Trans Canada Highway, Montreal, Quebec, Canada H4T 1A3

Fireplaces / Heating & Cooling call: 705-721-1212 • Grills call: 705-726-4278
napoleonproducts.com