

INSTALLER: LEAVE THIS MANUAL WITH THE APPLIANCE.  
 CONSUMER: RETAIN THIS MANUAL FOR FUTURE REFERENCE.  
 NEVER LEAVE CHILDREN OR OTHER AT RISK INDIVIDUALS ALONE WITH THE APPLIANCE



# INSTALLATION AND OPERATING INSTRUCTIONS

CONFORMS TO AMERICAN NATIONAL STANDARDS: ANSI Z21.50, CERTIFIED TO CANADIAN CSA 2.22 FOR VENTED GAS FIREPLACES.

EN

FR  
PG  
65

CERTIFIED FOR CANADA AND UNITED STATES USING ANSI/CSA METHODS.

## SAFETY INFORMATION

### **WARNING**

If the information in these instructions are not followed exactly, a fire or explosion may result causing property damage, personal injury or loss of life.

- Do not store or use gasoline or other flammable vapors and liquids in the vicinity of this or any other appliance.
- **WHAT TO DO IF YOU SMELL GAS:**
  - Do not try to light any appliance.
  - Do not touch any electrical switch; do not use any phone in your building.
  - Immediately call your gas supplier from a neighbour's phone. Follow the gas supplier's instructions.
  - If you cannot reach your gas supplier, call the fire department.
- Installation and service must be performed by a qualified installer, service agency or the supplier.

This appliance may be installed in an aftermarket, permanently located, manufactured home (USA only) or mobile home, where not prohibited by local codes.

This appliance is only for use with the type of gas indicated on the rating plate. This appliance is not convertible for use with other gases, unless a certified kit is used.

Decorative Product: Not for use as a heating appliance.



BARRIER



**HDX35NT**  
NATURAL GAS

**HDX35PT**  
PROPANE

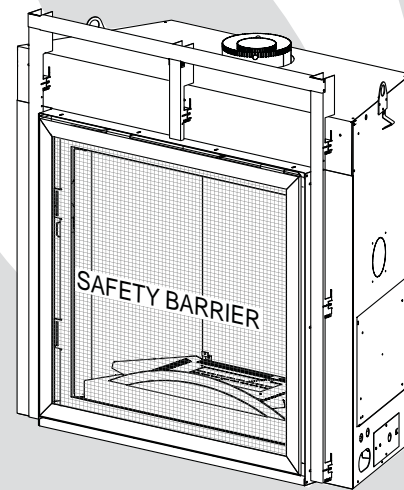

### **DANGER**

**HOT GLASS WILL CAUSE BURNS.**

**DO NOT TOUCH GLASS UNTIL COOLED.**

**NEVER ALLOW CHILDREN TO TOUCH GLASS.**

A barrier designed to reduce the risk of burns from the hot viewing glass is provided with this appliance and shall be installed for the protection of children and other at-risk individuals.



Wolf Steel Ltd., 24 Napoleon Rd., Barrie, ON, L4M 0G8 Canada /  
 103 Miller Drive, Crittenden, Kentucky, USA, 41030

Phone (705)721-1212 • Fax (705)722-6031 • [www.napoleonfireplaces.com](http://www.napoleonfireplaces.com) • [hearth@napoleonproducts.com](mailto:hearth@napoleonproducts.com)

# TABLE OF CONTENTS



The camera icon indicates video tutorials are available as additional reference, visit <http://www.napoleonfireplaces.com/category/product-support/support-centre/>

EN

<b>1.0</b>	<b>INSTALLATION OVERVIEW</b>	<b>3</b>
<b>2.0</b>	<b>INTRODUCTION</b>	<b>4</b>
2.1	DIMENSIONS	5
2.2	GENERAL INSTRUCTIONS	5
2.3	GENERAL INFORMATION	6
2.4	RATING PLATE INFORMATION	7
<b>3.0</b>	<b>VENTING</b>	<b>8</b>
3.1	VENTING LENGTHS AND COMPONENTS	9
3.2	TYPICAL VENT INSTALLATION	10
3.3	VENT TERMINAL CLEARANCES	11
3.4	VENT APPLICATION FLOW CHART	12
3.5	DEFINITIONS	12
3.6	ELBOW VENT LENGTH VALUES	12
3.7	HORIZONTAL TERMINATION	13
3.8	VERTICAL TERMINATION	15
<b>4.0</b>	<b>INSTALLATION</b>	<b>17</b>
4.1	WALL AND CEILING PROTECTION	17
4.1.1	HORIZONTAL INSTALLATION	18
4.1.2	VERTICAL INSTALLATION	18
4.2	USING FLEXIBLE VENT COMPONENTS	19
4.2.1	HORIZONTAL AIR TERMINAL INSTALLATION	19
4.2.2	VERTICAL AIR TERMINAL INSTALLATION	20
4.2.3	APPLIANCE VENT CONNECTION	21
4.3	MOBILE HOME INSTALLATION	21
4.4	GAS INSTALLATION	22
<b>5.0</b>	<b>FRAMING</b>	<b>23</b>
5.1	INSTALLING NON-COMBUSTIBLE BOARD	26
5.2	MINIMUM CLEARANCE TO COMBUSTIBLE ENCLOSURES	28
5.2.1	CLEARANCE TO COMBUSTIBLES ENCLOSURE WITHOUT ALCOVE	29
5.2.2	ALCOVE CLEARANCE TO COMBUSTIBLES ENCLOSURE	30
5.3	MINIMUM COMBUSTIBLE MANTEL CLEARANCES	31
5.4	NON-COMBUSTIBLE FINISHING MATERIAL	32
<b>6.0</b>	<b>FINISHING</b>	<b>33</b>
6.1	SAFETY BARRIER REMOVAL / INSTALLATION	33
6.2	LATCH DOOR REMOVAL / INSTALLATION	34
6.3	GLASS DOOR REMOVAL / INSTALLATION	35
6.4	BURNER INSTALLATION	36
6.5	LOGO PLACEMENT	36
<b>7.0</b>	<b>ELECTRICAL INFORMATION</b>	<b>37</b>
7.1	HARD WIRING CONNECTION	37
7.2	RECEPTACLE WIRING DIAGRAM	37
7.3	BATTERY HOLDER INSTALLATION	38
7.4	WIRING DIAGRAM	39
<b>8.0</b>	<b>OPERATION</b>	<b>40</b>
8.1	GENERAL TRANSMITTER LAYOUT	40
8.2	INITIALIZING THE TRANSMITTER/BATTERY HOLDER FOR THE FIRST TIME	40
8.3	TEMPERATURE DISPLAY	41
8.4	SMART THERMOSTAT	41
8.5	ROOM TEMPERATURE	41
8.6	FLAME HEIGHT	41
8.7	NIGHT LIGHT DIMMER CONTROL	42
8.8	CONTINUOUS PILOT / INTERMITTENT PILOT (CPI / IPI) SELECTION	42
8.9	KEY LOCK	42
8.10	LOW BATTERY / MANUAL BYPASS	43
<b>9.0</b>	<b>OPERATING INSTRUCTIONS</b>	<b>44</b>
9.1	RESTRICTING VERTICAL VENTS	45
9.2	PILOT BURNER ADJUSTMENT	45
9.3	VENTURI ADJUSTMENT	46
9.4	FLAME CHARACTERISTICS	46
<b>10.0</b>	<b>MAINTENANCE</b>	<b>47</b>
10.1	ANNUAL MAINTENANCE	48
10.2	CONTROL ACCESS	49
10.3	BURNER REMOVAL	50
10.4	BRICK PANEL REMOVAL	50
10.5	PORCELAIN PANEL REMOVAL	50
10.6	MEDIA TRAY REMOVAL (GLASS ONLY)	50
10.7	NIGHT LIGHT™ REPLACEMENT	51
10.8	GLASS / DOOR REPLACEMENT	52
10.9	CARE OF GLASS	52
10.10	CARE OF PLATED PARTS	52
<b>11.0</b>	<b>REPLACEMENTS</b>	<b>53</b>
<b>12.0</b>	<b>OVERVIEW</b>	<b>54</b>
<b>13.0</b>	<b>VALVE TRAIN ASSEMBLY</b>	<b>55</b>
<b>14.0</b>	<b>LOG BURNER</b>	<b>56</b>
<b>15.0</b>	<b>GLASS BURNER</b>	<b>57</b>
<b>16.0</b>	<b>ACCESSORIES</b>	<b>58</b>
<b>17.0</b>	<b>TROUBLESHOOTING</b>	<b>59</b>
<b>18.0</b>	<b>WARRANTY</b>	<b>62</b>
<b>19.0</b>	<b>SERVICE HISTORY</b>	<b>63</b>

# 1.0 INSTALLATION OVERVIEW

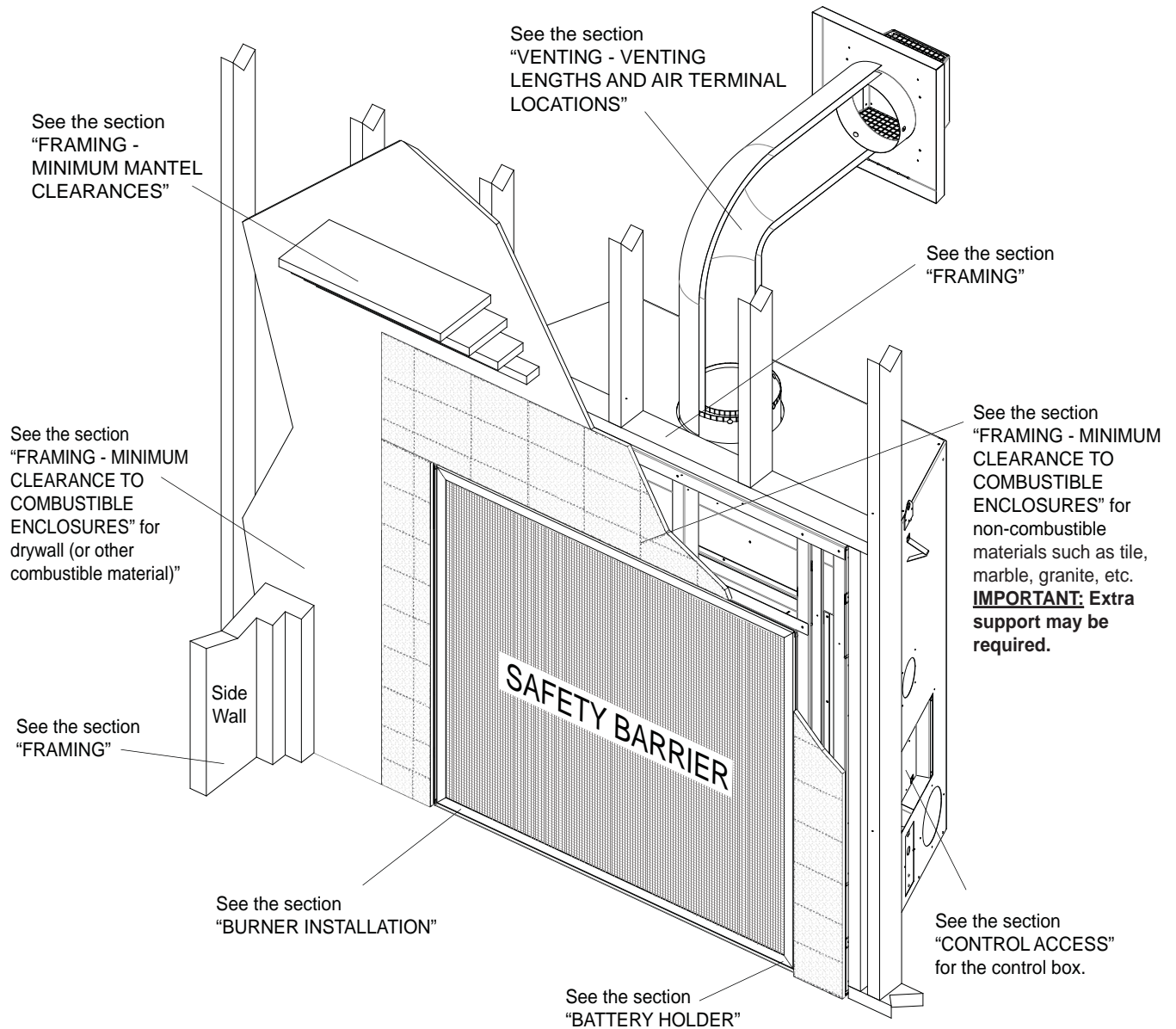

Batteries must be disposed of according to the local laws and regulations. Some batteries may be recycled, and may be accepted for disposal at your local recycling center. Check with your municipality for recycling instructions.

## 2.0 INTRODUCTION

 **WARNING**

- **THIS APPLIANCE IS HOT WHEN OPERATED AND CAN CAUSE SEVERE BURNS IF CONTACTED.**
- **ANY CHANGES OR ALTERATIONS TO THIS APPLIANCE OR ITS CONTROLS CAN BE DANGEROUS AND IS PROHIBITED.**
- Do not operate appliance before reading and understanding operating instructions. Failure to operate appliance according to operating instructions could cause fire or injury.
- Risk of fire or asphyxiation do not operate appliance with fixed glass removed.
- Do not connect 110 volts to the control valve.
- Risk of burns. The appliance should be turned off and cooled before servicing.
- Do not install damaged, incomplete or substitute components.
- Risk of cuts and abrasions. Wear protective gloves and safety glasses during installation. Sheet metal edges may be sharp.
- Do not burn wood or other materials in this appliance.
- **Children and adults should be alerted to the hazards of high surface temperature and should stay away to avoid burns or clothing ignition.**
- **Young children should be carefully supervised when they are in the same room as the appliance. Toddlers, young children and others may be susceptible to accidental contact burns. A physical barrier is recommended if there are at risk individuals in the house. To restrict access to an appliance, install an adjustable safety gate to keep toddlers, young children and other at risk individuals out of the room and away from hot surfaces.**
- **Clothing or other flammable material should not be placed on or near the appliance.**
- **Due to high temperatures, the appliance should be located out of traffic and away from furniture and draperies.**
- Ensure you have incorporated adequate safety measure to protect infants/toddlers from touching hot surfaces.
- Even after the appliance is out, the glass and/or screen will remain hot for an extended period of time.
- Check with your local hearth specialty dealer for safety screens and hearth guards to protect children from hot surfaces. These screens and guards must be fastened to the floor.
- **Any safety screen, guard or barrier removed for servicing the appliance, must be replaced prior to operating the appliance.**
- The appliance is a vented gas-fired appliance. Do not burn wood or other materials in the appliance
- It is imperative that the control compartments, burners and circulating blower and its passageway in the appliance and venting system are kept clean. The appliance and its venting system should be inspected before use and at least annually by a qualified service person. More frequent cleaning may be required due to excessive lint from carpeting, bedding material, etc. The appliance area must be kept clear and free from combustible materials, gasoline and other flammable vapors and liquids.
- Under no circumstances should this appliance be modified.
- This appliance must not be connected to a chimney flue pipe serving a separate solid fuel burning appliance.
- Do not use this appliance if any part has been under water. Immediately call a qualified service technician to inspect the appliance and to replace any part of the control system and any gas control which has been under water.
- Do not operate the appliance with the glass door removed, cracked or broken. Replacement of the glass should be done by a licensed or qualified service person.
- Do not strike or slam shut the appliance glass door.
- When equipped with pressure relief doors, they must be kept closed while the appliance is operating to prevent exhaust fumes containing carbon monoxide, from entering into the home. Temperatures of the exhaust escaping through these openings can also cause the surrounding combustible materials to overheat and catch fire.
- **Only doors / optional fronts certified with the appliance are to be installed on the appliance.**
- Keep the packaging material out of reach of children and dispose of the material in a safe manner. As with all plastic bags, these are not toys and should be kept away from children and infants.
- As with any combustion appliance, we recommend having your appliance regularly inspected and serviced as well as having a Carbon Monoxide Detector installed in the same area to defend you and your family against Carbon Monoxide.
- Ensure clearances to combustibles are maintained when building a mantel or shelves above the appliance. Elevated temperatures on the wall or in the air above the appliance can cause melting, discolouration or damage of decorations, a T.V. or other electronic components.
- **A barrier designed to reduce the risk of burns from the hot viewing glass is provided with this appliance and shall be installed.**
- **If the barrier becomes damaged, the barrier shall be replaced with the manufacturer's barrier for this appliance.**
- **Installation and repair should be done by a qualified service person. The appliance should be inspected before use and at least annually by a professional service person. More frequent cleaning may be required due to excessive lint from carpeting, bedding material, etc. It is imperative that control compartments, burners and circulating air passageways of the appliance be kept clean.**

3.2C



## 2.1 DIMENSIONS

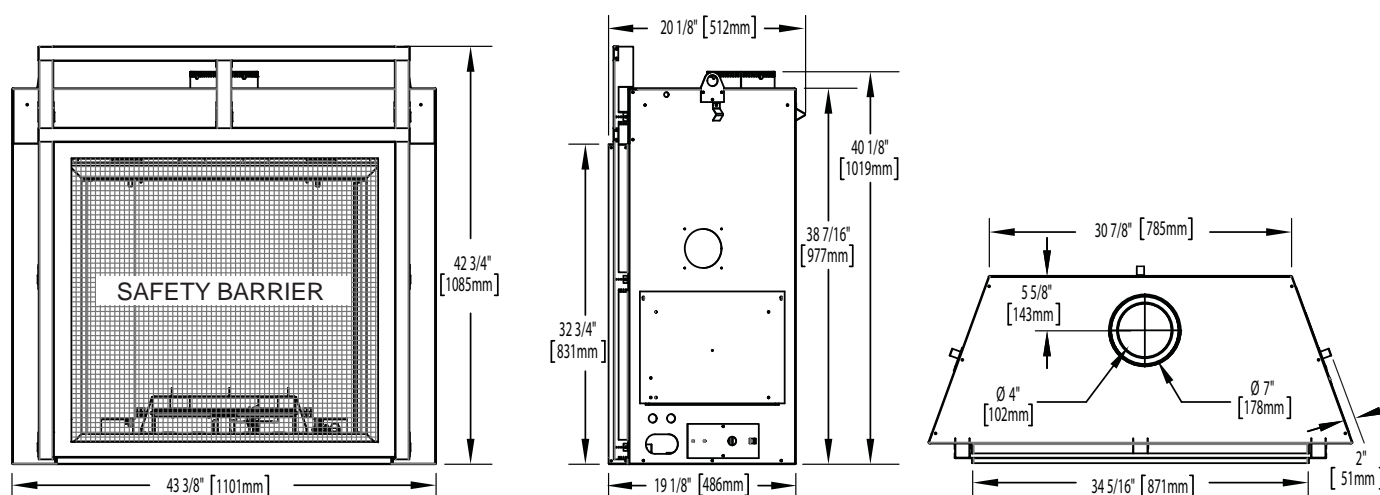

## 2.2 GENERAL INSTRUCTIONS

<b>! WARNING</b>
<b>ALWAYS LIGHT THE PILOT WHETHER FOR THE FIRST TIME OR IF THE GAS SUPPLY HAS RUN OUT, WITH THE GLASS DOOR OPENED OR REMOVED.</b>
<b>PROVIDE ADEQUATE CLEARANCE FOR SERVICING AND OPERATING THE APPLIANCE.</b>
<b>PROVIDE ADEQUATE VENTILATION.</b>
<b>NEVER OBSTRUCT THE FRONT OPENING OF THE APPLIANCE.</b>
<b>OBJECTS PLACED IN FRONT OF THE APPLIANCE MUST BE KEPT A MINIMUM OF 48" (1219mm) FROM THE FRONT FACE OF THE APPLIANCE.</b>
<b>SURFACES AROUND AND ESPECIALLY ABOVE THE APPLIANCE CAN BECOME HOT. AVOID CONTACT WHEN THE APPLIANCE IS OPERATING.</b>
<b>FIRE RISK. EXPLOSION HAZARD.</b>
<b>HIGH PRESSURE WILL DAMAGE VALVE. DISCONNECT GAS SUPPLY PIPING BEFORE PRESSURE TESTING GAS LINE AT TEST PRESSURES ABOVE 1/2 PSIG. CLOSE THE MANUAL SHUT-OFF VALVE BEFORE PRESSURE TESTING GAS LINE AT TEST PRESSURES EQUAL TO OR LESS THAN 1/2 PSIG (35 mb).</b>
<b>USE ONLY WOLF STEEL APPROVED OPTIONAL ACCESSORIES AND REPLACEMENT PARTS WITH THIS APPLIANCE. USING NON-LISTED ACCESSORIES (BLOWERS, DOORS, LOUVRES, TRIMS, GAS COMPONENTS, VENTING COMPONENTS, ETC.) COULD RESULT IN A SAFETY HAZARD AND WILL VOID THE WARRANTY AND CERTIFICATION.</b>

**THIS GAS APPLIANCE SHOULD BE INSTALLED AND SERVICED BY A QUALIFIED INSTALLER** to conform with local codes. Installation practices vary from region to region and it is important to know the specifics that apply to your area, for example in Massachusetts State:

- This product must be installed by a licensed plumber or gas fitter when installed within the commonwealth of Massachusetts.
- The appliance damper must be removed or welded in the open position prior to installation of an appliance insert or gas log.
- The appliance off valve must be a "T" handle gas cock.
- The flexible connector must not be longer than 36 inches (914mm).
- A Carbon Monoxide detector is required in all rooms containing gas fired appliances.
- The appliance is not approved for installation in a bedroom or bathroom unless the unit is a direct vent sealed combustion product.

The installation must conform with local codes or, in absence of local codes, the National Gas and Propane Installation Code CSA B149.1 in Canada, or the National Fuel Gas Code, ANSI Z223.1 / NFPA 54 in the United States. Suitable for mobile home installation if installed in accordance with the current standard CAN/CSA Z240MH Series, for gas equipped mobile homes, in Canada or ANSI Z223.1 and NFPA 54 in the United States.

As long as the required clearance to combustibles is maintained, the most desirable and beneficial location for an appliance is in the center of a building, thereby allowing the most efficient use of the heat created. The location of windows, doors and the traffic flow in the room where the appliance is to be located should be considered. If possible, you should choose a location where the vent will pass through the house without cutting a floor or roof joist.

If the appliance is installed directly on carpeting, vinyl tile or other combustible material other than wood flooring, the appliance shall be installed on a metal or wood panel extending the full width and depth.

Some appliances have optional fans or blowers. If an optional fan or blower is installed, the junction box must be electrically connected and grounded in accordance with local codes, use the current CSA C22.1 Canadian Electrical Code in Canada or the ANSI/NFPA 70 National Electrical code in the United States.

4.1B



We suggest that our gas hearth products be installed and serviced by professionals who are certified in the U.S. by the National Fireplace Institute® (NFI) as NFI Gas Specialists

## 2.3 GENERAL INFORMATION

**FOR YOUR SATISFACTION, THIS APPLIANCE HAS BEEN TEST-FIRED TO ASSURE ITS OPERATION AND QUALITY!**

HDX35		
	NG	LP
Altitude (FT)	0-4,500	0-4500
Max. Input (BTU/HR)	35,000	35,000
Reduced Input (BTU/HR)	25,000	27,000
Min. Inlet Gas Supply Pressure	4.5" w.c. (11mb)	11" w.c. (27mb)
Max. Inlet Gas Supply Pressure	7" w.c. (17mb)	13" w.c. (32mb)
Manifold Pressure (Under Flow Conditions)	3.5" w.c. (9mb)	10" w.c. (25mb)

This appliance is approved for bathroom, bedroom and bed-sitting room installations and is certified for mobile home installation.

This appliance is only for use with the type of gas indicated on the rating plate. This appliance is not convertible for use with other gases, unless a certified kit is used.

When the appliance is installed at elevations above 4,500ft (1371m), and in the absence of specific recommendations from the local authority having jurisdiction, the certified high altitude input rating shall be reduced at the rate of 4% for each additional 1,000ft (305m).

Expansion / contraction noises during heating up and cooling down cycles are normal and are to be expected. Change in flame appearance from "HI" to "LO" is more evident in natural gas than in propane.

**A barrier designed to reduce the risk of burns from the hot viewing glass is provided with the appliance and must be installed.**

**NOTE:** The protective wrap on plated parts is best removed when the assembly is at room temperature but this can be improved if the assembly is warmed, using a hair dryer or similar heat source.

This appliance is equipped with a remote control system, which requires batteries (supplied) to be installed. The transmitter takes 1 9V battery and in the case of a power failure the receiver takes 4 "AA" batteries.

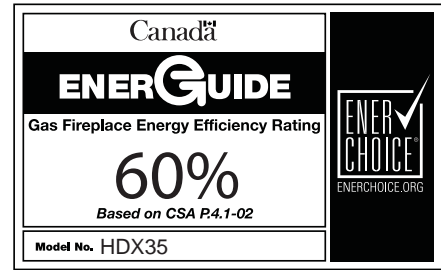

EN

2.4 RATING PLATE INFORMATION

**! WARNING**

**ALLOW APPLIANCE TO COOL BEFORE PERFORMING ANY MAINTANCE OR CLEANING.**

Both the rating plate and lighting instructions are attached to a cable and inserted along the left side of the appliance.

CONFORMS TO / CONFORME AUX: ANSI Z21.50-2014, CERTIFIED TO / CERTIFIE CSA 2.22-2014 VENTED GAS FIREPLACE / FOYER À GAZ VENTILÉ.

THIS APPLIANCE MUST BE INSTALLED IN ACCORDANCE WITH LOCAL CODES, IF ANY; IF NONE, FOLLOW THE CURRENT ANSI Z223.1 OR CSA B149, INSTALLATION CODES. VENTED GAS FIREPLACE. APPROVED FOR BEDROOM, BATHROOM AND BED-SITTING ROOM INSTALLATION. SUITABLE FOR MOBILE HOME INSTALLATION IF INSTALLED IN ACCORDANCE WITH THE CURRENT STANDARD CAN/CSA Z240MH SERIES GAS EQUIPPED MOBILE HOMES, IN CANADA OR IN THE UNITED STATES THE MANUFACTURED HOME CONSTRUCTION AND SAFETY STANDARD, TITLE 24 CFR, PART 3280. WHEN THIS US STANDARD IS NOT APPLICABLE USE THE STANDARD FOR FIRE SAFETY CRITERIA FOR MANUFACTURED HOME INSTALLATIONS, SITES AND COMMUNITIES, ANSI/NFPA 501A. FOR USE WITH BARRIER W565-0194. FOLLOW THE INSTALLATION INSTRUCTIONS LOCATED IN THE INSTALLATION MANUAL.

INSTALLER L'APPAREIL SELON LES CODES D'INSTALLATION ANSI Z223.1 OU CSA-B149 EN VIGEUR. FOYER À GAZ VENTILÉ. HOMOLOGUÉ POUR INSTALLATION DANS UNE CHAMBRE À COUCHER, UNE SALLE DE BAIN ET UN STUDIO. APPROPRIÉ POUR INSTALLATION DANS UNE MAISON MOBILE SI SON INSTALLATION CONFORME AUX EXIGENCES DE LA NORME CAN/CSA Z240MH SÉRIE DE MAISONS MOBILES ÉQUIPÉES AU GAZ EN VIGEUR AU CANADA OU AUX ÉTATS-UNIS DE LA NORME DE SÉCURITÉ ET DE CONSTRUCTION DE MAISONS MANUFACTURÉES, TITRE 24 CFR, SECTION 3280. DANS LE CAS OU CETTE NORME D'ÉTATS-UNIS PEUT ÊTRE APPLIQUÉE, SE RÉFÉRER À LA NORME RELATIVE AU CRITÈRE DE MESURES DE SÉCURITÉ CONTRE L'INCENDIE POUR LES INSTALLATIONS DANS LES MAISONS MANUFACTURÉES, LES SITES ET LES COMMUNAUTÉS, ANSI/NFPA 501A. POUR UNE UTILISER AVEC BARRIÈRE W565-0194. SUIVEZ LES INSTRUCTIONS D'INSTALLATION SE TROUVENT DANS LE MANUEL D'INSTALLATION.

**ETL**  
Intertek

**DIRECT VENT GAS FIREPLACE. NOT FOR USE WITH SOLID FUEL. FOR USE WITH GLASS DOORS CERTIFIED WITH THIS UNIT ONLY.**

**MODEL NATURAL GAS / 9700539 (WSL)  4001657 (NGZ) MODEL PROPANE / GAZ NATURAL 4001658 (NAC)  4001659 (WUSA) PROPANE MODÈLE  HDX35N  CHDX35N  CHDX35P  HDX35P**

**WARNING: DO NOT ADD ANY MATERIAL TO THE APPLIANCE, WHICH WILL COME IN CONTACT WITH THE FLAMES, OTHER THAN THAT SUPPLIED BY THE MANUFACTURER WITH THE APPLIANCE DECORATIVE PRODUCT. NOT FOR USE AS A HEATING APPLIANCE.**

**MINIMUM CLEARANCE TO COMBUSTIBLE MATERIALS:**

TOP FLOOR	0"
RECESSED DEPTH	20 1/2"
SIDES	0"
BACK	0"
VENT TOP	2"
VENT SIDES & BOTTOM	1"
VERTICAL VENT MANTEL	8"

0-4500FT (0-1370M) ALTITUDE / ELEVATION INPUT / ALIMENTATION 0-4500FT (0-1370M) 35,000 BTU/H REDUCED INPUT / ALIMENTATION RÉDUITE 35,000 BTU/H 25,000 BTU/H MANIFOLD PRESSURE / PRESSION AU COLLECTEUR MINIMUM SUPPLY PRESSURE 7 MINIMUM SUPPLY PRESSURE 7 27,000 BTU/H 4.5" WATER COLUMN/D'UNE COLONNE D'EAU PRESSION D'ALIMENTATION MINIMALE 11" WATER COLUMN/D'UNE COLONNE D'EAU 7.0" WATER COLUMN/D'UNE COLONNE D'EAU MAXIMUM SUPPLY PRESSURE PRESSION D'ALIMENTATION MAXIMALE 13" WATER COLUMN/D'UNE COLONNE D'EAU 60% P4 FE 60%

THE APPLIANCE MUST BE VENTED USING THE APPROPRIATE NAPOLEON VENT KITS. SEE OWNERS INSTALLATION MANUAL FOR VENTING SPECIFICS. PROPER REINSTALLATION AND RESEALING IS NECESSARY AFTER SERVICING THE VENT-AIR INTAKE SYSTEM.

L'APPAREIL DOIT ÉVACUER SES GAZ EN UTILISANT L'ENSEMBLE D'ÉVACUATION PROPRE À NAPOLEON. RÉFÉRER AU MANUEL D'INSTALLATION DE PROPRIÉTAIRE POUR L'ÉVACUATION PRÉCISE. IL EST IMPORTANT DE BIEN RÉINSTALLER ET RESCELLER L'ÉVENT APRÈS AVOIR ASSURÉ LE MAINTIEN DU SYSTÈME DE PRISE D'AIR.

DESSUS, CÔTÉS & ARRIÈRE : SELON LES ESPACEURS DE DÉGAGEMENT POUR LES MATÉRIAUX D'OSSATURE SELON LA MANUEL DE PROPRIÉTAIRE POUR LES MATÉRIAUX DE FINITION. "L'EXTENSION HORIZONTALE MAXIMALE : 2". RÉFÉRER AU MANUEL D'INSTRUCTION POUR DES EXTENSIONS PLUS GRANDES. RÉFÉRER AU MANUEL D'INSTALLATION DE PROPRIÉTAIRE.

FOYER À D'ÉVENT DIRECT. UN COMBUSTIBLE SOLIDE NE PAS ÊTRE UTILISÉ AVEC CET APPAREIL. UTILISER AVEC LES PORTE VITRÉES HOMOLOGUÉES SÉULEMENT AVEC CETTE UNITÉ.

**ADVERTISSEMENT : N'AJOUTEZ PAS A CET APPAREIL AUCUN MATÉRIAU DEVANT ENTRER EN CONTACT AVEC LES FLAMMES AUTRE QUE CELUI QUI EST FOURNI AVEC CET APPAREIL PAR LE FABRICANT. PRODUIT DÉCORATIF: NE PAS UTILISER COMME APPAREIL DE CHAUFFAGE DÉGAGEMENTS MINIMAUX DES MATÉRIAUX COMBUSTIBLES :**

DESSUS	0"
PLANCHER	0"
PROFONDEUR DE L'ENCLAVE FACE	20 1/2"
CÔTÉS	0"
ARRIÈRE	0"
DESSUS DU CONDUIT D'ÉVENT	2"
CÔTÉS ET DESSUS DU CONDUIT D'ÉVENT	1"
CONDUIT D'ÉVENT VERTICAL	1"
TABLETTE	8"

OPTIONAL FAN KIT: NZ64  
ELECTRICAL RATING: 115V.60HZ. LESS THAN 12 AMPERES  
WOLF STEEL LTD. SERIAL NUMBER/ NO. DE SÉRIE: HDX35  
24 NAPOLEON ROAD, BARRIE, ON, L4M 0G8 CANADA W385-2000

ENSEMBLE DE VENTILATEUR FACULTATIF: NZ64  
SPÉCIFICATIONS ÉLECTRIQUES : 115 V, 60HZ. MOINS DE 12 AMPÈRES.

**INSTALLER:** It is your responsibility to check off the appropriate box on the rating plate according to the model, venting and gas type of the appliance.

The illustration is for reference only. Refer to the rating plate on the appliance for accurate information.

**NOTE:** The rating plate must remain with the appliance at all times. It must not be removed.

## 3.0 VENTING

EN

**! WARNING****RISK OF FIRE, MAINTAIN SPECIFIED AIR SPACE CLEARANCES TO VENT PIPE AND APPLIANCE.**

**IF VENTING IS INCLUDED WITH SPACERS THE VENT SYSTEM MUST BE SUPPORTED EVERY 3FT (0.9m) FOR BOTH VERTICAL AND HORIZONTAL RUNS. USE SUPPORTS OR EQUIVALENT NON-COMBUSTIBLE STRAPPING TO MAINTAIN THE REQUIRED CLEARANCE FROM COMBUSTIBLES. USE WOLF STEEL LTD. SUPPORT RING ASSEMBLY W010-0370 OR EQUIVALENT NON-COMBUSTIBLE STRAPPING TO MAINTAIN THE MINIMUM CLEARANCE TO COMBUSTIBLES FOR BOTH VERTICAL AND HORIZONTAL RUNS. SPACERS ARE ATTACHED TO THE INNER PIPE AT PREDETERMINED INTERVALS TO MAINTAIN AN EVEN AIR GAP TO THE OUTER PIPE. THIS GAP IS REQUIRED FOR SAFE OPERATION. A SPACER IS REQUIRED AT THE START, MIDDLE AND END OF EACH ELBOW TO ENSURE THIS GAP IS MAINTAINED. THESE SPACERS MUST NOT BE REMOVED.**

**THIS APPLIANCE USES A 4" (102mm) EXHAUST / 7" (178mm) AIR INTAKE VENT PIPE SYSTEM.**

**Refer to the section applicable to your installation.**

For safe and proper operation of the appliance follow the venting instruction exactly. Deviation from the minimum vertical vent length can create difficulty in burner start-up and/or carboning. Under extreme vent configurations, allow several minutes (5-15) for the flame to stabilize after ignition. Although not a requirement, it is recommended for vent lengths that pass through unheated spaces (attics, garages, crawl spaces) be insulated with the insulation wrapped in a protective sleeve to minimize condensation. Provide a means for visually checking the vent connection to the appliance after the appliance is installed. Use a firestop, vent pipe shield or attic insulation shield when penetrating interior walls, floor or ceiling.

**NOTE: If for any reason the vent air intake system is disassembled; reinstall per the instructions provided for the initial installation.**

---

7.1C

### 3.1 VENTING LENGTHS AND COMPONENTS

Use only Wolf Steel, Simpson Dura-Vent, Selkirk Direct Temp, American Metal Amerivent or Metal-Fab venting components. Minimum and maximum vent lengths, for both horizontal and vertical installations, and air terminal locations for either system are set out in this manual and must be adhered to. For Simpson Dura-Vent, Selkirk Direct Temp, American Metal Amerivent and Metal-Fab follow the installation procedure provided with the venting components.

A starter adaptor must be used with the following vent systems and may be purchased from the corresponding supplier:

PART	4"/7"	SUPPLIER	WEBSITE
Duravent	W175-0053	Wolf Steel	www.duravent.com
Amerivent	4DSC-N2	American Metal	www.americanmetalproducts.com
Direct Temp	4DT-AAN	Selkirk	www.selkirkcorp.com
SuperSeal	4DNA	Metal-Fab	www.mtlfab.com

**For Simpson Dura-Vent, Selkirk Direct Temp, American Metal Amerivent and Metal-Fab follow the installation procedure found on the website for your venting supplier.**

For vent systems that provide seals on the inner exhaust flue, only the outer air intake joints must be sealed using a red high temperature silicone (RTV). This same sealant may be used on both the inner exhaust and outer intake vent pipe joints of all other approved vent systems except for the exhaust vent pipe connection to the appliance flue collar which must be sealed using the black high temperature sealant Mill Pac. High temperature sealant must be ordered separately.

When using Wolf Steel venting components, use only approved Wolf Steel rigid / flexible components with the following termination kits: wall terminal kit **GD222**, **GD222R**, or 1/12 to 7/12 pitch roof terminal kit **GD110**, 8/12 to 12/12 roof terminal kit **GD111**, flat roof terminal kit **GD112** or periscope kit **GD201** (for wall penetration below grade). With flexible venting, in conjunction with the various terminations, use either the 5 foot (1.5m) vent kit **GD220** or the 10 foot (3.1m) vent kit **GD330**.

**For optimum flame appearance and appliance performance, keep the vent length and number of elbows to a minimum. The air terminal must remain unobstructed at all times. Examine the air terminal at least once a year to verify that it is unobstructed and undamaged.**

**Rigid and flexible venting systems must not be combined. Different venting manufacturer components must not be combined.**

These vent kits allow for either horizontal or vertical venting of the appliance. The maximum allowable horizontal run is 20 feet (6.1m). The maximum allowable vertical vent length is 40 feet (12.2m). The maximum number of vent connections is two horizontally or three vertically (excluding the appliance and the air terminal connections) when using flexible venting.

8.1A



3.2 TYPICAL VENT INSTALLATION

EN

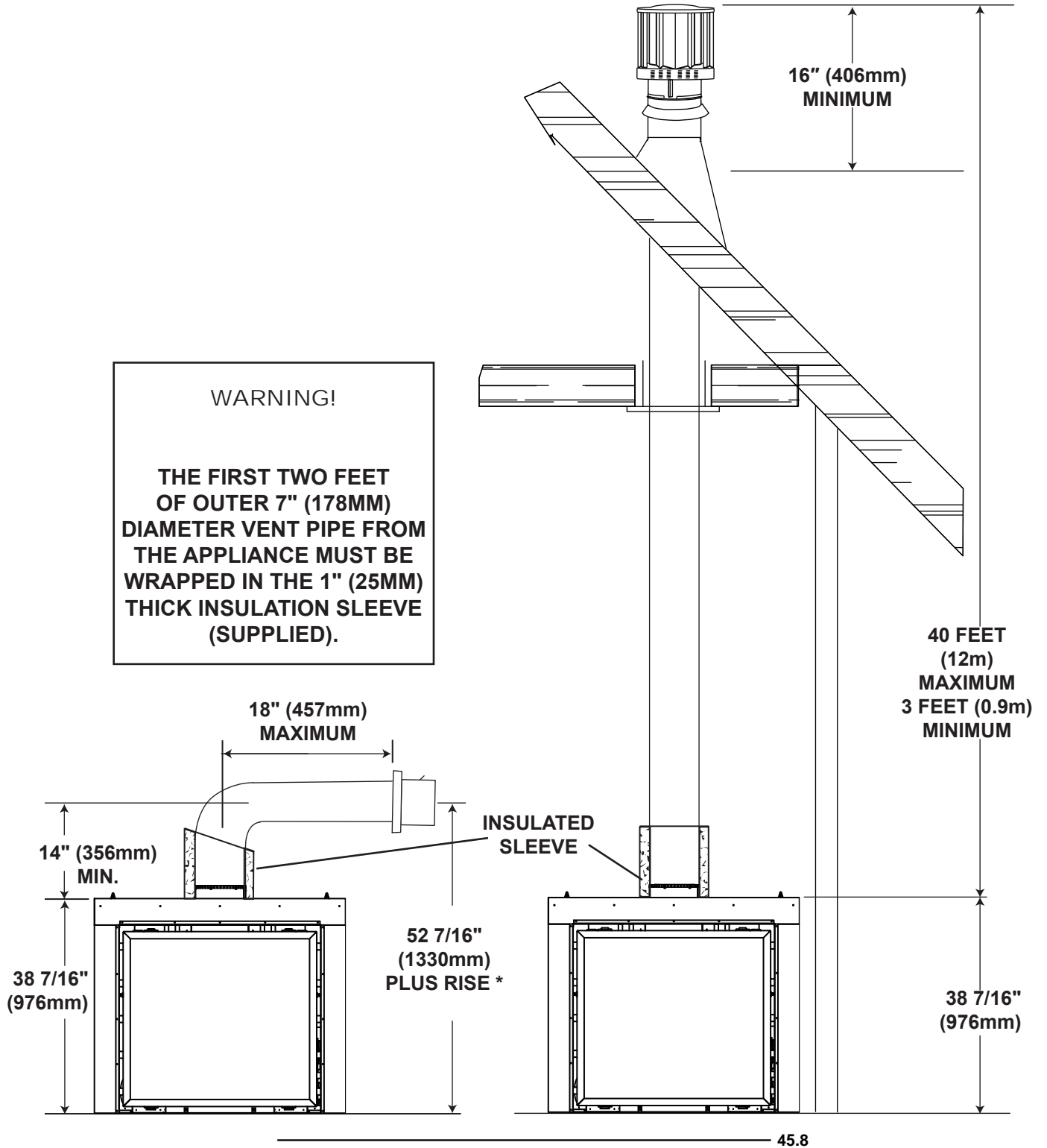

Refer to "VENTING" section.

3.3 VENT TERMINAL CLEARANCES

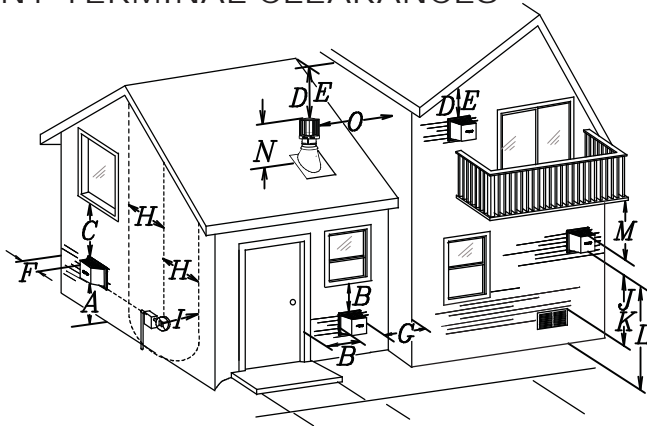

COVERED BALCONY APPLICATIONS ††\*

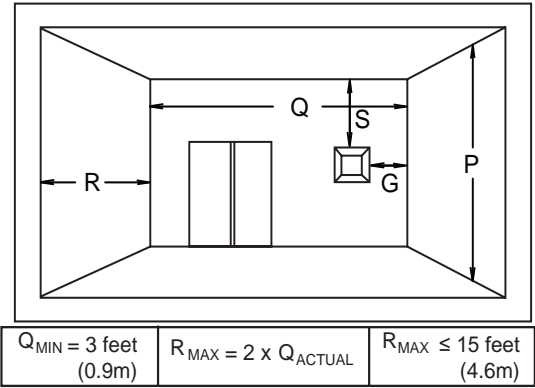

$Q_{MIN} = 3 \text{ feet}$ (0.9m)	$R_{MAX} = 2 \times Q_{ACTUAL}$	$R_{MAX} \leq 15 \text{ feet}$ (4.6m)
--------------------------------------	---------------------------------	--

EN

INSTALLATIONS			
	CANADA	U.S.A.	
A	12" (305mm)	12" (305mm)	Clearance above grade, veranda porch, deck or balcony.
B	12" (305mm) <sup>Δ</sup>	9" (229mm) <sup>Δ</sup>	Clearance to windows or doors that open.
C	12" (305mm)*	12" (305mm) *	Clearance to permanently closed windows.
D	18" (457mm)**	18" (457mm)**	Vertical clearance to ventilated soffits located above the terminal within a horizontal distance of 2' (0.6m) from the center line of the terminal.
E	12" (305mm)**	12" (305mm)**	Clearance to unventilated soffit.
F	0" (0mm)	0" (0mm)	Clearance to an outside corner wall.
G	0" (0mm)***	0" (0mm)***	Clearance to an inside <b>non-combustible</b> corner wall or protruding <b>non-combustible</b> obstructions (chimney, etc.).
	2" (51mm)***	2" (51mm)***	Clearance to an inside <b>combustible</b> corner wall or protruding <b>combustible</b> obstructions (vent chase, etc.).
H	3' (0.9m)	3' (0.9m)****	Clearance to each side of the center line extended above the meter / regulator assembly to a maximum vertical distance of 15' (4.6m).
I	3' (0.9m)	3' (0.9m)****	Clearance to a service regulator vent outlet.
J	12" (305mm)	9" (229mm)	Clearance to a non-mechanical air supply inlet to the building or a combustion air inlet to any other appliance.
K	6' (1.8m)	3' (0.9m) †	Clearance to a mechanical air supply inlet.
L	7' (2.1m) ‡	7' (2.1m) ****	Clearance above a paved sidewalk or paved driveway located on public property.
M	12" (305mm)††	12" (305mm)****	Clearance under a veranda, porch or deck.
N	16" (406mm)	16" (406mm)	Clearance above the roof.
O	2' (0.6m)†*	2' (0.6m) †*	Clearance from an adjacent wall including neighbouring buildings.
P	8' (2.4m)	8' (2.4m)	Roof must be <b>non-combustible</b> without openings.
Q	3' (0.9m)	3' (0.9m)	See chart for wider wall dimensions.
R	6' (1.8m)	6' (1.8m)	See chart for deeper wall dimensions. The terminal shall not be installed on any wall that has an opening between the terminal and the open side of the structure.
S	12" (305mm)	12" (305mm)	Clearance under a covered balcony

Δ The terminal shall not be located less than 6 feet under a window that opens on a horizontal plane in a structure with three walls and a roof.

\* Recommended to prevent condensation on windows and thermal breakage

\*\* It is recommended to use a heat shield and to maximize the distance to vinyl clad soffits.

\*\*\* The periscope requires a minimum 18 inches clearance from an inside corner.

\*\*\*\* This is a recommended distance. For additional requirements check local codes.

† 3 feet above if within 10 feet horizontally.

‡ A vent shall not terminate where it may cause hazardous frost or ice accumulations on adjacent property surfaces.

†† Permitted only if the veranda, porch, or deck is fully open on a minimum of two sides beneath the floor.

†\* Recommended to prevent recirculation of exhaust products. For additional requirements check local codes.

††\* Permitted only if the balcony is fully open on a minimum of one side.

**NOTE:** Clearances are in accordance with local installation codes and the requirements of the gas supplier.

3.4 VENT APPLICATION FLOW CHART

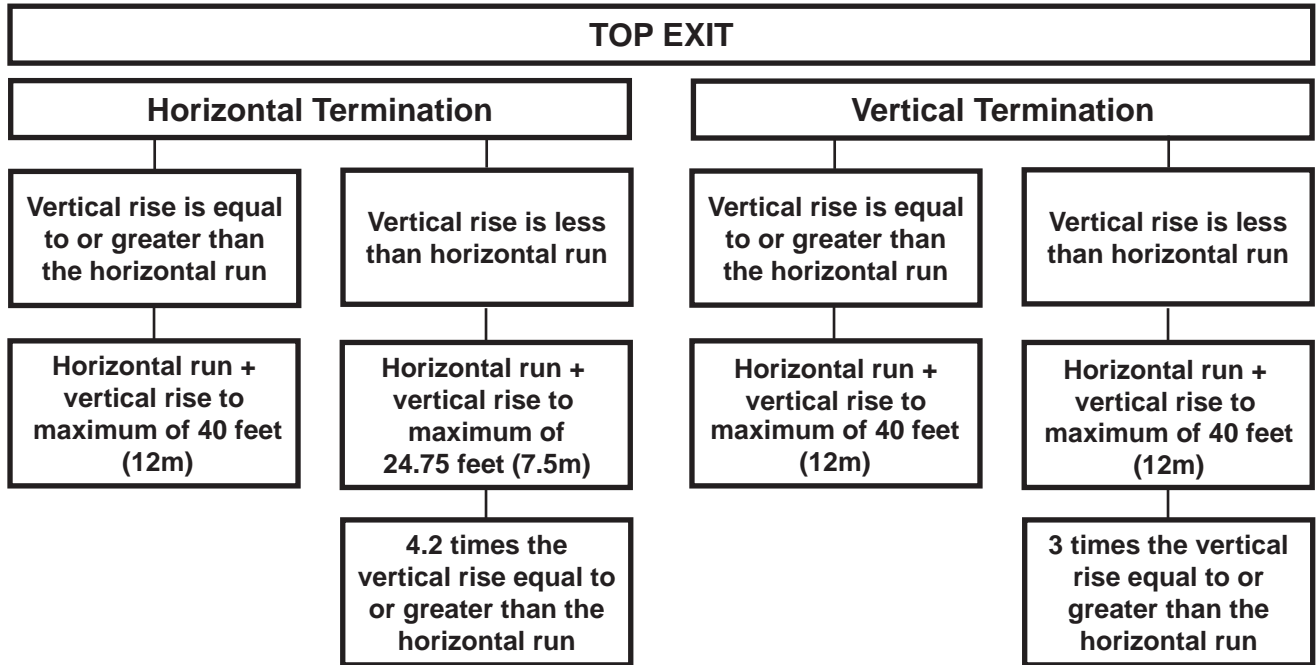

13.1A

3.5 DEFINITIONS

For the following symbols used in the venting calculations and examples are:

- > - greater than
- ≥ - equal to or greater than
- < - less than
- ≤ - equal to or less than
- H<sub>T</sub> - total of both horizontal vent lengths (H<sub>r</sub>) and offsets (H<sub>o</sub>) in feet
- H<sub>R</sub> - combined horizontal vent lengths in feet
- H<sub>O</sub> - offset factor: .03 (total degrees of offset - 90°\*) in feet
- V<sub>T</sub> - combined vertical vent lengths in feet

14.1

3.6 ELBOW VENT LENGTH VALUES

	<u>FEET</u>	<u>INCHES</u>	<u>MILLIMETERS</u>
1°	0.03	0.5	12.7
15°	0.45	6.0	152.4
30°	0.9	11.0	279.4
45°	1.35	16.0	406.4
90°*	2.7	32.0	812.8

\* The first 90° offset has a zero value and is shown in the formula as - 90°

15.1A

3.7 HORIZONTAL TERMINATION

EN

$$(H_T) \leq (V_T)$$

Simple venting configuration (only one 90° elbow)

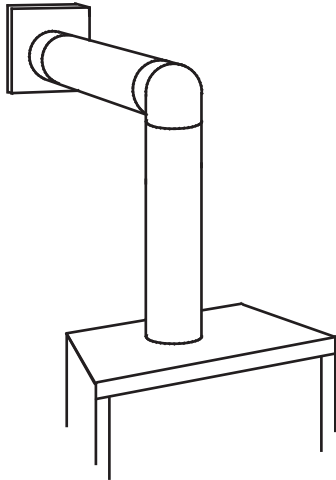

See graph to determine the required vertical rise  $V_T$  for the required horizontal run  $H_T$ .

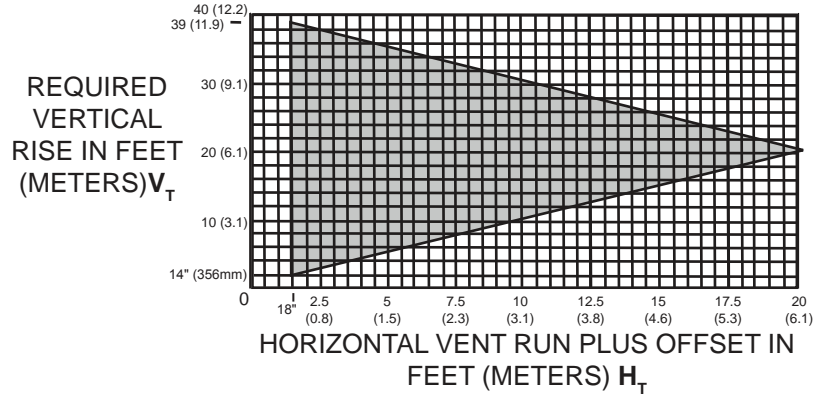

The shaded area within the lines represents acceptable values for  $H_T$  and  $V_T$

For vent configurations requiring more than one 90° elbow, the following formulas apply:

**Formula 1:**  $H_T \leq V_T$

**Formula 2:**  $H_T + V_T \leq 40 \text{ feet (12.2m)}$

**Example:**

$V_1 = 3 \text{ FT (0.9m)}$

$V_2 = 8 \text{ FT (2.4m)}$

$V_T = V_1 + V_2 = 3 \text{ FT (0.9m)} + 8 \text{ FT (2.4m)} = 11 \text{ FT (3.4m)}$

$H_1 = 2.5 \text{ FT (0.8m)}$

$H_2 = 2 \text{ FT (0.6m)}$

$H_R = H_1 + H_2 = 2.5 \text{ FT (0.8m)} + 2 \text{ FT (0.6m)} = 4.5 \text{ FT (1.4m)}$

$H_o = .03 \text{ (three } 90^\circ \text{ elbows - } 90^\circ) = .03 \text{ (} 270^\circ - 90^\circ) = 5.4 \text{ FT (1.7m)}$

$H_T = H_R + H_o = 4.5 \text{ FT (1.4m)} + 5.4 \text{ FT (1.6m)} = 9.9 \text{ FT (3m)}$

$H_T + V_T = 9.9 \text{ FT (3m)} + 11 \text{ FT (3.4m)} = 20.9 \text{ FT (6.4m)}$

**Formula 1:**  $H_T \leq V_T$   
 $9.9 \text{ FT (3m)} \leq 11 \text{ FT (3.4m)}$

**Formula 2:**  $H_T + V_T \leq 40 \text{ FT (12.2m)}$   
 $20.9 \text{ FT (6.4m)} \leq 40 \text{ FT (12.2m)}$

Since both formulas are met, this vent configuration is acceptable.

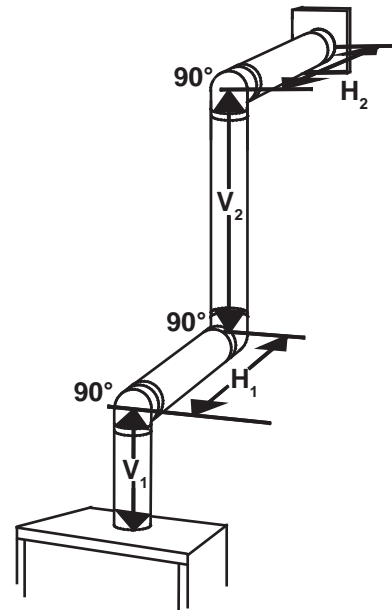

16.1B

$$(H_T) > (V_T)$$

**Simple venting configuration (only one 90° elbow)**

See graph to determine the required vertical rise  $V_T$  for the required horizontal run  $H_T$ .

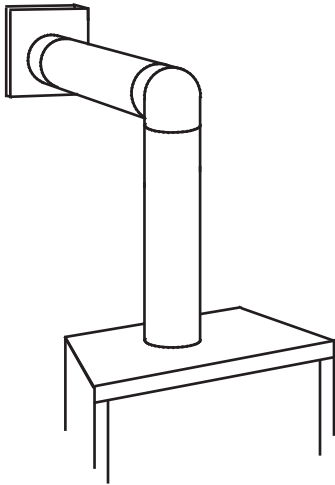

REQUIRED VERTICAL RISE IN INCHES (MILLIMETERS)  $V_T$

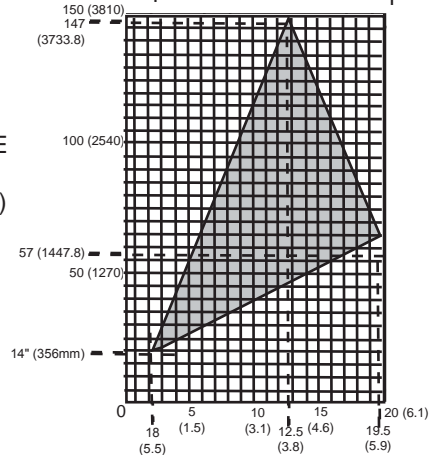

HORIZONTAL VENT RUN PLUS OFFSET IN FEET (METERS)  $H_T$   
The shaded area within the lines represents acceptable values for  $H_T$  and  $V_T$

For vent configurations requiring more than one 90° elbow, the following formulas apply:

**Formula 1:**  $H_T \leq 4.2 V_T$

**Formula 2:**  $H_T + V_T \leq 24.75$  feet (7.5m)

**Example:**

$V_1 = V_T = 6$  FT (1.8m)

$H_1 = 3$  FT (0.9m)

$H_2 = 5$  FT (1.5m)

$H_R = H_1 + H_2 = 3$  FT (0.9m) + 5 FT (1.5m) = 8 FT (2.4m)

$H_O = .03$  (two 90° elbows - 90°) = .03 (180° - 90°) = 2.7 FT (0.8m)

$H_T = H_R + H_O = 8$  FT (2.4m) + 2.7 FT (0.8m) = 10.7 FT (3.3m)

$H_T + V_T = 10.7$  FT (3.3m) + 6 FT (1.8m) = 16.7 FT (5.1m)

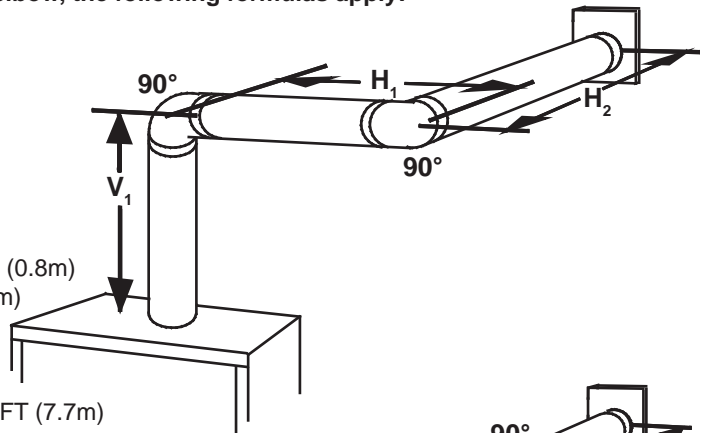

**Formula 1:**  $H_T \leq 4.2 V_T$

$4.2 V_T = 4.2$  FT (1.3m) x 6 FT (1.8m) = 25.2 FT (7.7m)

$10.7$  FT (3.3m)  $\leq$  25.2 FT (7.7m)

**Formula 2:**  $H_T + V_T \leq 24.75$  FT (7.5m)

$16.7$  FT (5.1m)  $\leq$  24.75 FT (7.5m)

Since both formulas are met, this vent configuration is acceptable.

**Example:**

$V_1 = 4$  FT (1.2m)

$V_2 = 1.5$  FT (0.5m)

$V_T = V_1 + V_2 = 4$  FT (1.2m) + 1.5 FT (0.5m) = 5.5 FT (1.7m)

$H_1 = 2$  FT (0.6m)

$H_2 = 1$  FT (0.3m)

$H_3 = 1$  FT (0.3m)

$H_4 = 1.5$  FT (0.5m)

$H_R = H_1 + H_2 + H_3 + H_4 = 2$  FT (0.6m) + 1 FT (0.3m) + 1 FT (0.3m) + 1.5 FT (0.5m) = 5.5 FT (1.7m)

$H_O = .03$  (four 90° elbows - 90°) = .03 (360° - 90°) = 8.1 FT (2.5m)

$H_T = H_R + H_O = 5.5$  FT (1.7m) + 8.1 FT (2.5m) = 13.6 FT (4.2m)

$H_T + V_T = 13.6$  FT (4.2m) + 5.5 FT (1.7m) = 19.1 FT (5.8m)

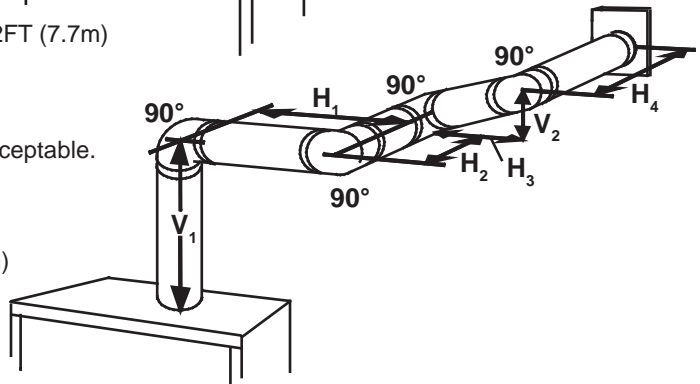

**Formula 1:**  $H_T \leq 4.2 V_T$

$4.2 V_T = 4.2$  FT (1.3m) x 5.5 FT (1.7m) = 23.1 FT (7m)

$13.6$  FT (4.2m)  $\leq$  23.1 FT (7m)

**Formula 2:**  $H_T + V_T \leq 24.75$  FT (7.5m)

$19.1$  FT (5.8m)  $\leq$  24.75 FT (7.5m)

Since both formulas are met, this vent configuration is acceptable.



3.8 VERTICAL TERMINATION

EN

$(H_T) \leq (V_T)$

Simple venting configurations.

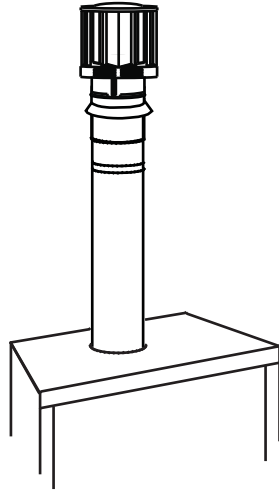

See graph to determine the required vertical rise  $V_T$  for the required horizontal run  $H_T$ .

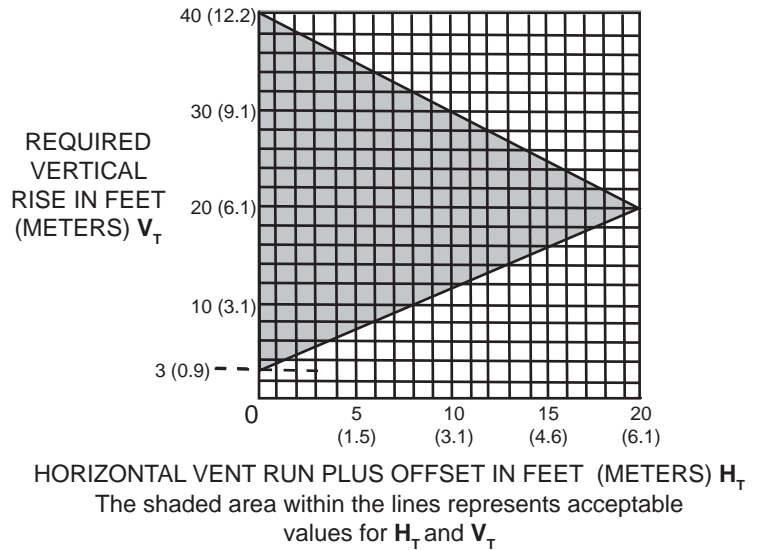

For vent configurations requiring one or more 90° elbows the following formulas apply:

Formula 1:  $H_T \leq V_T$

Formula 2:  $H_T + V_T \leq 40 \text{ feet (12.2m)}$

Example:

$V_1 = 5 \text{ FT (1.5m)}$

$V_2 = 6 \text{ FT (1.8m)}$

$V_3 = 10 \text{ FT (3.1m)}$

$V_T = V_1 + V_2 + V_3 = 5\text{FT (1.5m)} + 6\text{FT (1.8m)} + 10\text{FT (3.1m)} = 21\text{FT (6.4m)}$

$H_1 = 8 \text{ FT (2.4m)}$

$H_2 = 2.5 \text{ FT (0.8m)}$

$H_R = H_1 + H_2 = 8\text{FT (2.4m)} + 2.5\text{FT (0.8m)} = 10.5 \text{ FT (3.2m)}$

$H_O = .03 \text{ (four } 90^\circ \text{ elbows} - 90^\circ)$

$= .03 \text{ (} 360^\circ - 90^\circ) = 8.1 \text{ FT (2.5m)}$

$H_T = H_R + H_O = 10.5\text{FT (3.2m)} + 8.1\text{FT (2.5m)} = 18.6\text{FT (5.7m)}$

$H_T + V_T = 18.6\text{FT (5.7m)} + 21\text{FT (6.4m)} = 39.6\text{FT (12.1m)}$

Formula 1:  $H_T \leq V_T$   
 $18.6\text{FT (5.7m)} \leq 21\text{FT (6.4m)}$

Formula 2:  $H_T + V_T \leq 40 \text{ FT (12.19m)}$   
 $39.6\text{FT (12.1m)} \leq 40\text{FT (12.2m)}$

Since both formulas are met, this vent configuration is acceptable.

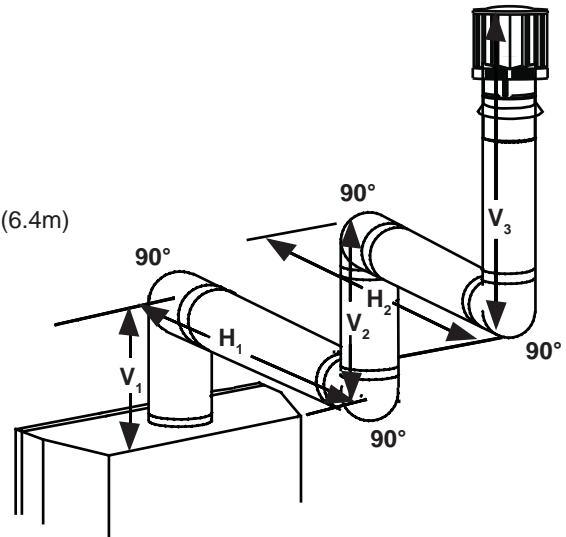

18.1A

$$(H_T) > (V_T)$$

**Simple venting configurations.**

See graph to determine the required vertical rise  $V_T$  for the required horizontal run  $H_T$ .

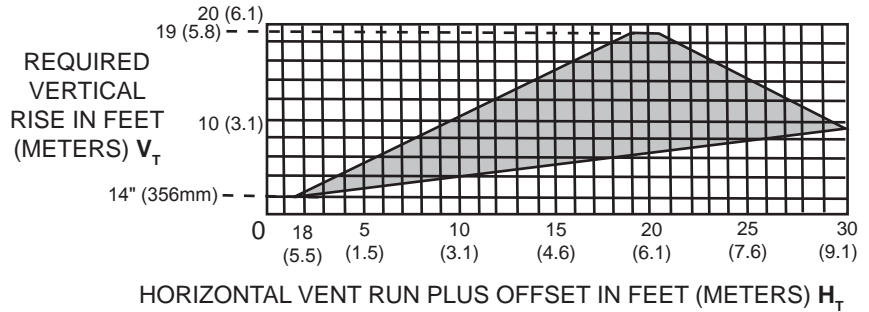
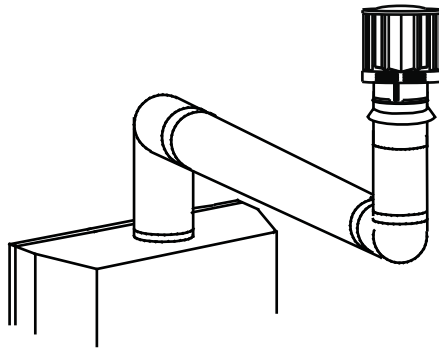

The shaded area within the lines represents acceptable values for  $H_T$  and  $V_T$

For vent configurations requiring more than two 90° elbows the following formulas apply:

**Formula 1:**  $H_T \leq 3V_T$

**Formula 2:**  $H_T + V_T \leq 40$  feet (12.2m)

**Example:**

$V_1 = 2$  FT (0.6m)

$V_2 = 1$  FT (0.3m)

$V_3 = 1.5$  FT (0.5m)

$V_T = V_1 + V_2 + V_3 = 2\text{FT} (0.6\text{m}) + 1\text{FT} (0.3\text{m}) + 1.5\text{FT} (0.5\text{m}) = 4.5\text{FT} (1.4\text{m})$

$H_1 = 6$  FT (1.8m)

$H_2 = 2$  FT (0.6m)

$H_R = H_1 + H_2 = 6\text{FT} (1.8\text{m}) + 2\text{FT} (0.6\text{m}) = 8$  FT (2.4m)

$H_0 = .03$  (four 90° elbows - 90°)

$= .03$  (360° - 90°) = 8.1 FT (2.5m)

$H_T = H_R + H_0 = 8\text{FT} (2.4\text{m}) + 8.1\text{FT} (2.5\text{m}) = 16.1\text{FT} (4.9\text{m})$

$H_T + V_T = 16.1\text{FT} (4.9\text{m}) + 4.5\text{FT} (1.4\text{m}) = 20.6$  FT (6.3m)

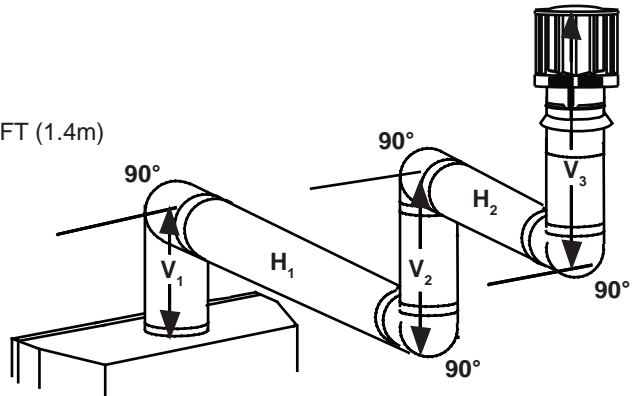

**Formula 1:**  $H_T \leq 3V_T$   
 $3V_T = 3\text{FT} (0.9\text{m}) \times 4.5\text{FT} (1.4\text{m}) = 13.5\text{FT} (4.1\text{m})$   
 $16.1\text{FT} (4.9\text{m}) > 13.5\text{FT} (4.1\text{m})$

Since this formula is not met, this vent configuration is **unacceptable**.

**Formula 2:**  $H_T + V_T \leq 40$  feet (12.2m)  
 $20.6\text{FT} (6.3\text{m}) \leq 40$  (12.2m)

Since only formula 2 is met, this vent configuration is unacceptable and a new appliance location or vent configuration will need to be established to satisfy both formulas.

## 4.0 INSTALLATION

 <b>WARNING</b>
<b>ENSURE TO UNPACK ALL LOOSE MATERIALS FROM INSIDE THE FIREBOX PRIOR TO HOOKING UP THE GAS AND ELECTRICAL SUPPLY.</b>
<b>IF YOUR APPLIANCE IS SUPPLIED WITH A REMOTE ENSURE THE REMOTE RECEIVER IS IN THE "OFF" POSITION PRIOR TO HOOKING UP THE GAS AND ELECTRICAL SUPPLY TO THE APPLIANCE.</b>
<b>FOR SAFE AND PROPER OPERATION OF THE APPLIANCE, FOLLOW THE VENTING INSTRUCTIONS EXACTLY.</b>
<b>ALL INNER EXHAUST AND OUTER INTAKE VENT PIPE JOINTS MAY BE SEALED USING EITHER RED RTV HIGH TEMP SILICONE SEALANT W573-0002 (NOT SUPPLIED) OR BLACK HIGH TEMP MILL PAC W573-0007 (NOT SUPPLIED) WITH THE EXCEPTION OF THE APPLIANCE EXHAUST FLUE COLLAR WHICH MUST BE SEALED USING MILL PAC.</b>
<b>IF USING PIPE CLAMPS TO CONNECT VENT COMPONENTS, 3 SCREWS MUST ALSO BE USED TO ENSURE THE CONNECTION CANNOT SLIP OFF.</b>
<b>DO NOT CLAMP THE FLEXIBLE VENT PIPE.</b>
<b>RISK OF FIRE, EXPLOSION OR ASPHYXIATION. IMPROPER SUPPORT OF THE ENTIRE VENTING SYSTEM MAY ALLOW VENT TO SAG AND SEPARATE. USE VENT RUN SUPPORTS AND CONNECT VENT SECTIONS PER INSTALLATION INSTRUCTIONS.</b>
<b>RISK OF FIRE, DO NOT ALLOW LOOSE MATERIALS OR INSULATION TO TOUCH THE VENT PIPE. REMOVE INSULATION TO ALLOW FOR THE INSTALLATION OF THE ATTIC SHIELD AND TO MAINTAIN CLEARANCES TO COMBUSTIBLES.</b>

68.2B

### 4.1 WALL AND CEILING PROTECTION

 <b>WARNING</b>
<b>DO NOT FILL THE SPACE BETWEEN THE VENT PIPE AND ENCLOSURE WITH ANY TYPE OF MATERIAL. DO NOT PACK INSULATION OR COMBUSTIBLES BETWEEN CEILING FIRESTOPS. ALWAYS MAINTAIN SPECIFIED CLEARANCES AROUND VENTING AND FIRESTOP SYSTEMS. INSTALL WALL SHIELDS AND FIRESTOPS AS SPECIFIED. FAILURE TO KEEP INSULATION OR OTHER MATERIALS AWAY FROM VENT PIPE MAY CAUSE FIRE.</b>

70.1

For optimum performance it is recommended that all horizontal runs have a minimum of 1/4" (6.4mm) rise per foot (0.3m) using flexible venting. For safe and proper operation of the appliance, follow the venting instructions exactly.

For clearance to combustible materials from the vent pipe, see "FRAMING" section.

## 4.1.1 HORIZONTAL INSTALLATION

**! WARNING**

**THE FIRESTOP ASSEMBLY MUST BE INSTALLED WITH THE VENT SHIELD TO THE TOP.**

**TERMINALS MUST NOT BE RECESSED INTO A WALL OR SIDING MORE THAN THE DEPTH OF THE RETURN FLANGE OF THE MOUNTING PLATE.**

This application occurs when venting through an exterior wall. Having determined the correct height for the air terminal location, cut and frame a hole in the exterior wall as illustrated to accommodate the firestop assembly. Dry fit the firestop assembly before proceeding to ensure the brackets on the rear surface fit to the inside surface of the horizontal framing.

The vent shield must be installed to the full depth of the combustible wall. The length of the vent shield may be cut shorter for combustible walls that are less than 6" (152mm) thick. **NOTE: Bend the tabs for reduced side clearances or move the shield for reduced top clearances.**

- A. Apply a bead of caulking (not supplied) around the corner edge of the inside surface of the firestop assembly, fit the firestop assembly to the hole and secure using the 4 screws (supplied in your manual baggie).

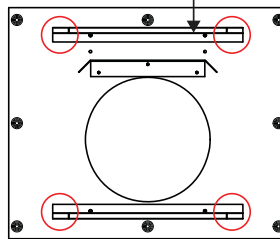

- B. Once the vent pipe is installed in its final position, apply high temperature sealant W573-0007 (not supplied) between the pipe and the firestop.

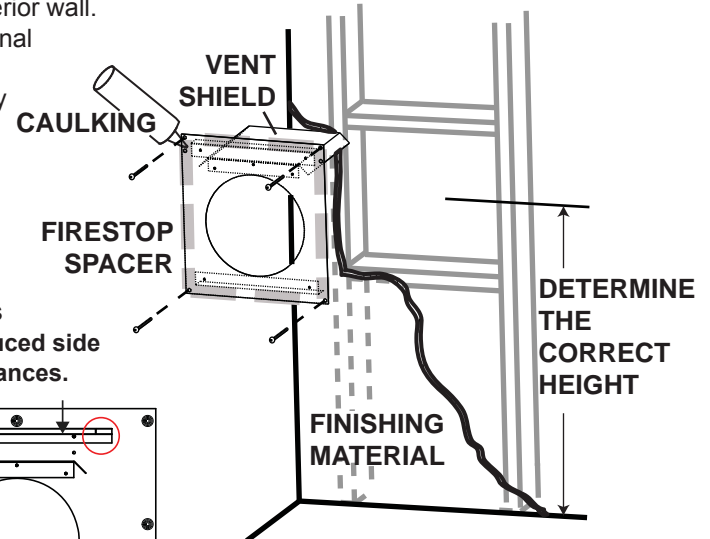

20.7A

## 4.1.2 VERTICAL INSTALLATION

This application occurs when venting through a roof. Installation kits for various roof pitches are available from your authorized dealer / distributor. See accessories to order specific kits required.

- A. Determine the air terminal location, cut and frame a square opening as illustrated in the ceiling and the roof to provide the minimum 1" (25mm) clearance between the vent pipe and any combustible material. Try to center the vent pipe location midway between two joists to prevent having to cut them. Use a plumb bob to line up the center of the openings. A vent pipe shield will prevent any materials such as insulation, from filling up the 1" (25mm) air space around the pipe. Nail headers between the joist for extra support.
- B. Apply a bead of caulking (not supplied) to the framework or to the Wolf Steel vent pipe shield plate or equivalent (in the case of a finished ceiling), and secure over the opening in the ceiling. A firestop must be placed on the bottom of each framed opening in a roof or ceiling that the venting system passes through. Apply a bead of caulking all around and place a firestop spacer over the vent shield to restrict cold air from being drawn into the room or around the fireplace. Ensure that both spacer and shield maintain the required clearance to combustibles. Once the vent pipe is installed in its final position, apply sealant between the pipe and the firestop assembly.
- C. In the attic, slide the vent pipe collar down to cover up the open end of the shield and tighten. This will prevent any materials, such as insulation, from filling up the 1" (25mm) air space around the pipe.

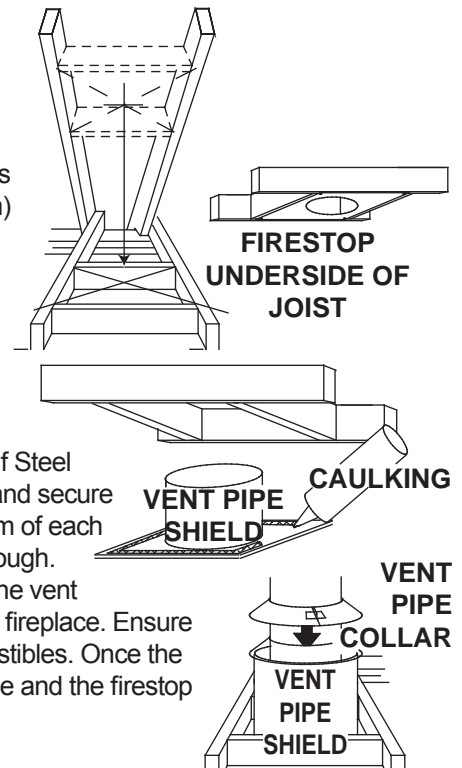

## 4.2 USING FLEXIBLE VENT COMPONENTS

**! WARNING**

**DO NOT ALLOW THE INNER FLEX PIPE TO BUNCH UP ON HORIZONTAL OR VERTICAL RUNS AND ELBOWS. KEEP IT PULLED TIGHT.**

**SPACERS ARE ATTACHED TO THE INNER FLEX PIPE AT PREDETERMINED INTERVALS TO MAINTAIN AN EVEN AIR GAP TO THE OUTER FLEX PIPE. THIS GAP IS REQUIRED FOR SAFE OPERATION. A SPACER IS REQUIRED AT THE START, MIDDLE AND END OF EACH ELBOW TO ENSURE THIS GAP IS MAINTAINED. THESE SPACERS MUST NOT BE REMOVED.**

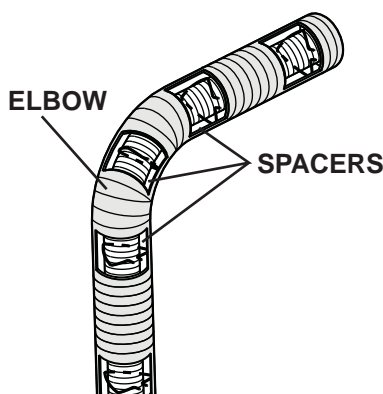

For safe and proper operation of the appliance, follow the venting instructions exactly.

All inner flex pipe and outer flex pipe joints may be sealed using high temperature sealant W573-0002 (not supplied) or the high temperature sealant W573-0007 Mill Pac (not supplied). However, the high temperature sealant W573-0007 Mill Pac (not supplied) must be used on the joint connecting the inner flex pipe and the exhaust flue collar.

**Use only approved flexible vent pipe kits marked:**



**“Wolf Steel Approved Venting” as identified by the stamp only on the outer flex pipe.**

22.1

## 4.2.1 HORIZONTAL AIR TERMINAL INSTALLATION

- A. Stretch the inner flex pipe to the required length needed for the finished wall surface. Apply a heavy bead of high temperature sealant W573-0007 Mill Pac (not supplied) to the inner sleeve of the air terminal. Slip the vent pipe a minimum of 2" (50.8mm) over the inner sleeve of the air terminal and secure with 3 #8 screws.
- B. Using the outer flex pipe, slide over the outer combustion air sleeve of the air terminal and secure with 3 #8 screws. Seal using high temperature sealant W573-0002 (not supplied).
- C. Insert the vent pipes through the firestop maintaining the required clearance to combustibles. Holding the air terminal (lettering in an upright, readable position), secure to the exterior wall and make weather tight by sealing with caulking (not supplied).
- D. If more vent pipe needs to be used to reach the fireplace, couple them together as illustrated. The vent system must be supported approximately every 3 feet (0.9mm) for both vertical and horizontal runs. Use noncombustible strapping to maintain the minimum 1" (25.4mm) clearance to combustibles.

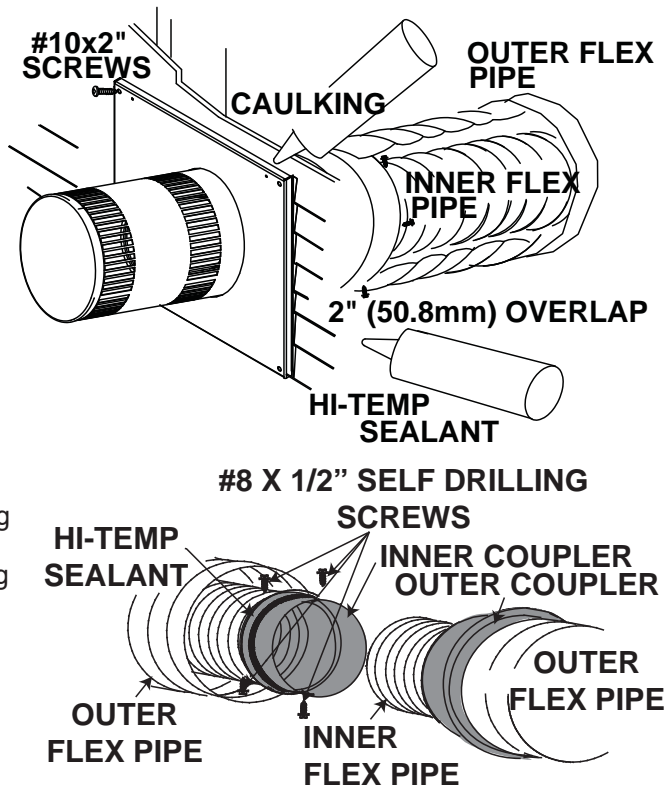

**The air terminal mounting plate may be recessed into the exterior wall or siding no greater than the depth of its return flange.**

23.3B



## 4.2.2 VERTICAL AIR TERMINAL INSTALLATION

**! WARNING****MAINTAIN A MINIMUM 2" (51mm) SPACE BETWEEN THE AIR INLET BASE AND THE STORM COLLAR.**

- A.** Fasten the roof support to the roof using the screws provided. The roof support is optional. In this case the venting is to be adequately supported using either an alternate method suitable to the authority having jurisdiction or the optional roof support.
- B.** Stretch the inner flex pipe to the required length. Slip the inner flex pipe a minimum of 2" (51mm) over the inner pipe of the air terminal connector and secure with 6 #8 screws. Seal using a heavy bead of high temperature sealant W573-0007 (not supplied).
- C.** Repeat using the outer flex pipe, using a heavy bead of high temperature sealant W573-0002 (not supplied).
- D.** Thread the air terminal connector / vent pipe assembly down through the roof. The air terminal must be positioned vertically and plumb. Attach the air terminal connector to the roof support, ensuring that the top of the air terminal is 16" (406mm) above the highest point that it penetrates the roof.
- E.** Remove nails from the shingles, above and to the sides of the air terminal connector. Place the flashing over the air terminal connector leaving a min. 3/4" (19mm) of the air terminal connector showing above the top of the flashing. Slide the flashing underneath the sides and upper edge of the shingles. Ensure that the air terminal connector is properly centred within the flashing, giving a 3/4" (19mm) margin all around. Fasten to the roof. Do not nail through the lower portion of the flashing. Make weather-tight by sealing with caulking. Where possible, cover the sides and top edges of the flashing with roofing material.
- F.** Aligning the seams of the terminal and air terminal connector, place the terminal over the air terminal connector making sure the vent pipe goes into the hole in the terminal. Secure with the three screws provided.
- G.** Apply a heavy bead of weatherproof caulking 2" (51mm) above the flashing. Install the storm collar around the air terminal and slide down to the caulking. Tighten to ensure that a weather-tight seal between the air terminal and the collar is achieved.
- H.** If more vent pipe needs to be used to reach the fireplace see "HORIZONTAL AIR TERMINAL INSTALLATION" section.

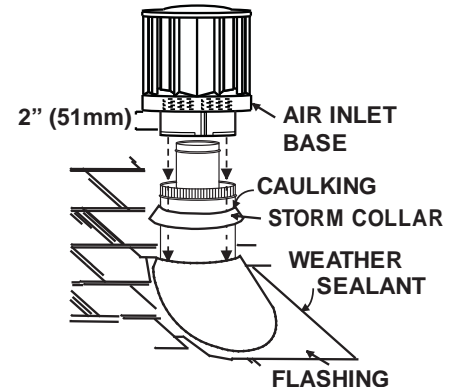
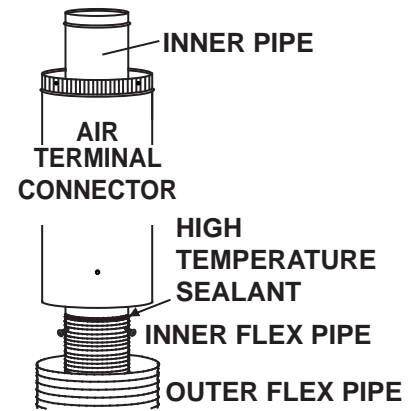
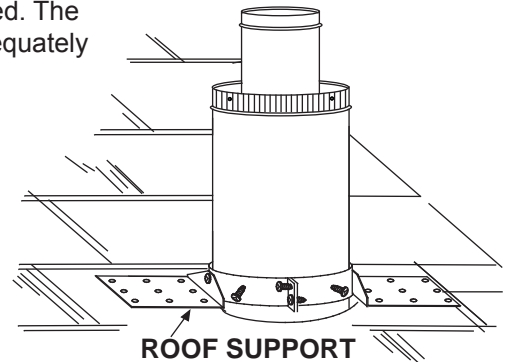

24.2A

### 4.2.3 APPLIANCE VENT CONNECTION

- A. Install the inner exhaust flue collar to the appliance. Secure with 3 screws. Seal the joint and screw holes using the high temperature sealant Mill-Pac W573-0007 (not supplied).
- B. Install the outer flex pipe to the appliance. Attach and seal the joints using a high temperature sealant.

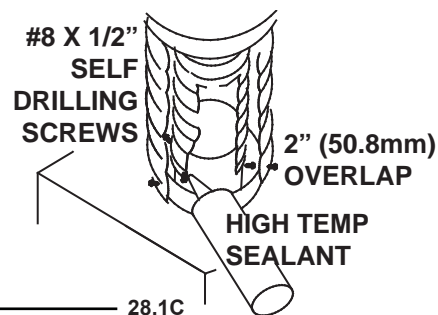

28.1C

### 4.3 MOBILE HOME INSTALLATION

This appliance is also certified to be installed as an OEM (Original Equipment Manufacturer) installation in a manufactured home (U.S. only) or mobile home and must be installed in accordance with the manufacturer's instructions and the Manufactured Home Construction and Safety Standard, Title 24 CFR, Part 3280, in the United States or the Mobile Home Standard, CAN/CSA Z240 MH Series, in Canada. This appliance is only for use with the type(s) of gas indicated on the rating plate.

This Mobile/Manufactured Home Listed appliance comes factory equipped with a means to secure the unit. Built in appliances are equipped with 1/4" (6.4mm) diameter holes located in the front left and right corners of the base. Use #10 hex head screws, inserted through the holes in the base to secure. For free standing products contact your local authorized dealer / distributor for the appropriate securing kit. For mobile home installations, the appliance must be fastened in place. It is recommended that the appliance be secured in all installations. Always turn off the pilot and the fuel supply at the source, prior to moving the mobile home. After moving the mobile home and prior to lighting the appliance, ensure that the logs are positioned correctly.

This appliance is certified to be installed in an aftermarket permanently located, manufactured (mobile) home, where not prohibited by local codes.

This appliance is only for use with the type of gas indicated on the rating plate. This appliance is not convertible for use with other gases, unless a certified kit is used.

A conversion kit is supplied with the mobile home appliance.

#### Conversion Kits

This appliance is field convertible between Natural Gas (NG) and Propane (LP).

To convert from one gas to another consult your Authorized dealer/distributor.

29.1A

## 4.4 GAS INSTALLATION

EN

 <b>WARNING</b>
<b>RISK OF FIRE, EXPLOSION OR ASPHYXIATION. ENSURE THERE ARE NO IGNITION SOURCES SUCH AS SPARKS OR OPEN FLAMES.</b>
<b>SUPPORT GAS CONTROL WHEN ATTACHING GAS SUPPLY PIPE TO PREVENT DAMAGING GAS LINE.</b>
<b>ALWAYS LIGHT THE PILOT WHETHER FOR THE FIRST TIME OR IF THE GAS SUPPLY HAS RUN OUT WITH THE GLASS DOOR OPENED OR REMOVED. PURGING OF THE GAS SUPPLY LINE SHOULD BE PERFORMED BY A QUALIFIED SERVICE TECHNICIAN. ASSURE THAT A CONTINUOUS GAS FLOW IS AT THE BURNER BEFORE CLOSING THE DOOR. ENSURE ADEQUATE VENTILATION. FOR GAS AND ELECTRICAL LOCATIONS, SEE "DIMENSION" SECTION.</b>
<b>ALL GAS CONNECTIONS MUST BE CONTAINED WITHIN THE APPLIANCE WHEN COMPLETE.</b>
<b>HIGH PRESSURE WILL DAMAGE VALVE. DISCONNECT GAS SUPPLY PIPING BEFORE TESTING GAS LINE AT TEST PRESSURES ABOVE 1/2 PSIG.</b>
<b>VALVE SETTINGS HAVE BEEN FACTORY SET, DO NOT CHANGE.</b>

Installation and servicing to be done by a qualified installer. **Do not use open flame.**

- Move the appliance into position and secure.
- If equipped with a flex connector the appliance is designed to accept a 1/2" (13mm) gas supply. Without the connector it is designed to accept a 3/8" (9.5mm) gas supply. The appliance is equipped with a manual shut off valve to turn off the gas supply to the appliance.
- Connect the gas supply in accordance to local codes. In the absence of local codes, install to the current CAN/CSA-B149.1 Installation Code in Canada or to the current National Fuel Gas Code, ANSI Z223.1 / NFPA 54 in the United States.
- When flexing any gas line, support the gas valve so that the lines are not bent or kinked.
- Check for gas leaks by brushing on a soap and water solution.

30.1A

**NOTE:** Connect the gas supply to the 1/2" shut off and flex connector (supplied). Ensure gas supply is secured.

## 5.0 FRAMING

 <b>WARNING</b>	
<b>RISK OF FIRE!</b>	
IN ORDER TO AVOID THE POSSIBILITY OF EXPOSED INSULATION OR VAPOUR BARRIER COMING IN CONTACT WITH THE APPLIANCE BODY, IT IS RECOMMENDED THAT THE WALLS OF THE APPLIANCE ENCLOSURE BE "FINISHED" (IE: DRYWALL / SHEETROCK), AS YOU WOULD FINISH ANY OTHER OUTSIDE WALL OF A HOME. THIS WILL ENSURE THAT CLEARANCE TO COMBUSTIBLES IS MAINTAINED WITHIN THE CAVITY.	
DO NOT NOTCH THE FRAMING AROUND THE APPLIANCE STAND-OFFS. FAILURE TO MAINTAIN AIR SPACE CLEARANCE MAY CAUSE OVER HEATING AND FIRE. PREVENT CONTACT WITH SAGGING OR LOOSE INSULATION OR FRAMING AND OTHER COMBUSTIBLE MATERIALS. BLOCK OPENING INTO THE CHASE TO PREVENT ENTRY OF BLOWN-IN INSULATION. MAKE SURE INSULATION AND OTHER MATERIALS ARE SECURED.	
WHEN CONSTRUCTING THE ENCLOSURE ALLOW FOR FINISHING MATERIAL THICKNESS TO MAINTAIN CLEARANCES. FRAMING OR FINISHING MATERIAL CLOSER THAN THE MINIMUMS LISTED MUST BE CONSTRUCTED ENTIRELY OF NON-COMBUSTIBLE MATERIALS. MATERIALS CONSISTING ENTIRELY OF STEEL, IRON, BRICK, TILE, CONCRETE, SLATE, GLASS OR PLASTERS, OR ANY COMBINATION THEREOF ARE SUITABLE. MATERIALS THAT ARE REPORTED AS PASSING ASTM E 136, STANDARD TEST METHOD FOR BEHAVIOUR OF MATERIALS IN A VERTICAL TUBE FURNACE AT 1382° F (750°C) AND UL763 SHALL BE CONSIDERED NON-COMBUSTIBLE MATERIALS.	
MINIMUM CLEARANCE TO COMBUSTIBLES MUST BE MAINTAINED OR A SERIOUS FIRE HAZARD COULD RESULT.	
THE APPLIANCE REQUIRES A MINIMUM ENCLOSURE HEIGHT. MEASURE FROM THE APPLIANCE BASE.	
IF STEEL STUD FRAMING KITS WITH CEMENT BOARD ARE PROVIDED, OR SPECIFIED IN THE INSTALLATION INSTRUCTIONS. THEY MUST BE INSTALLED.	
FINISHING MUST BE DONE USING A NON-COMBUSTIBLE MATERIAL EXTENDING FROM THE TOP OF THE APPLIANCE SUCH AS NON-COMBUSTIBLE BOARD, CERAMIC TILE, MARBLE, ETC. DO <b>NOT USE WOOD OR DRYWALL.</b> <b>ANY FIRE RATED DRYWALL IS NOT ACCEPTABLE.</b>	

71.1B

It is best to frame your appliance after it is positioned and the vent system is installed. Use the steel frame provided except when recessing into non-combustible material deeper than 1 1/2".

**Maintain these minimum clearances to combustibles from appliance and vent surfaces:**

**Appliance framing:**

Use steel framing provided.

**Non- Combustible Appliance finishing:**

- Front - 4 3/4" (121mm) to sides of appliance opening  
- 10" (254mm) above appliance opening

**Combustible Appliance finishing:**

- 70" (1778mm) from bottom of appliance to enclosure top  
- 2" (51mm) to top of vent pipe\*  
- 1" (25mm) to sides and bottom of vent pipe\*

**Ceiling height  
is minimum 24"  
(610mm) from the  
top of the appliance  
opening.**

\***HORIZONTAL VENT SECTIONS:** A minimum clearance of 2" (51mm) to the top and 1" (25mm) to the sides and bottom of the vent pipe on all horizontal runs to combustibles is required.

\***VERTICAL VENT SECTIONS:** A minimum of 1" (25mm) all around the vent pipe on all vertical runs to combustibles is required except for clearances in appliance enclosures. Use firestop spacer W500-0096 (not supplied).

\* When constructing the enclosure allow for finishing material thickness to maintain clearances.

**IMPORTANT:** Before finishing in the appliance test the operation using the remote control, cycling it through all of its different modes, see "OPERATION" section. Should trouble shooting be required, access to the controls can be made through the pre-finishing access panel.

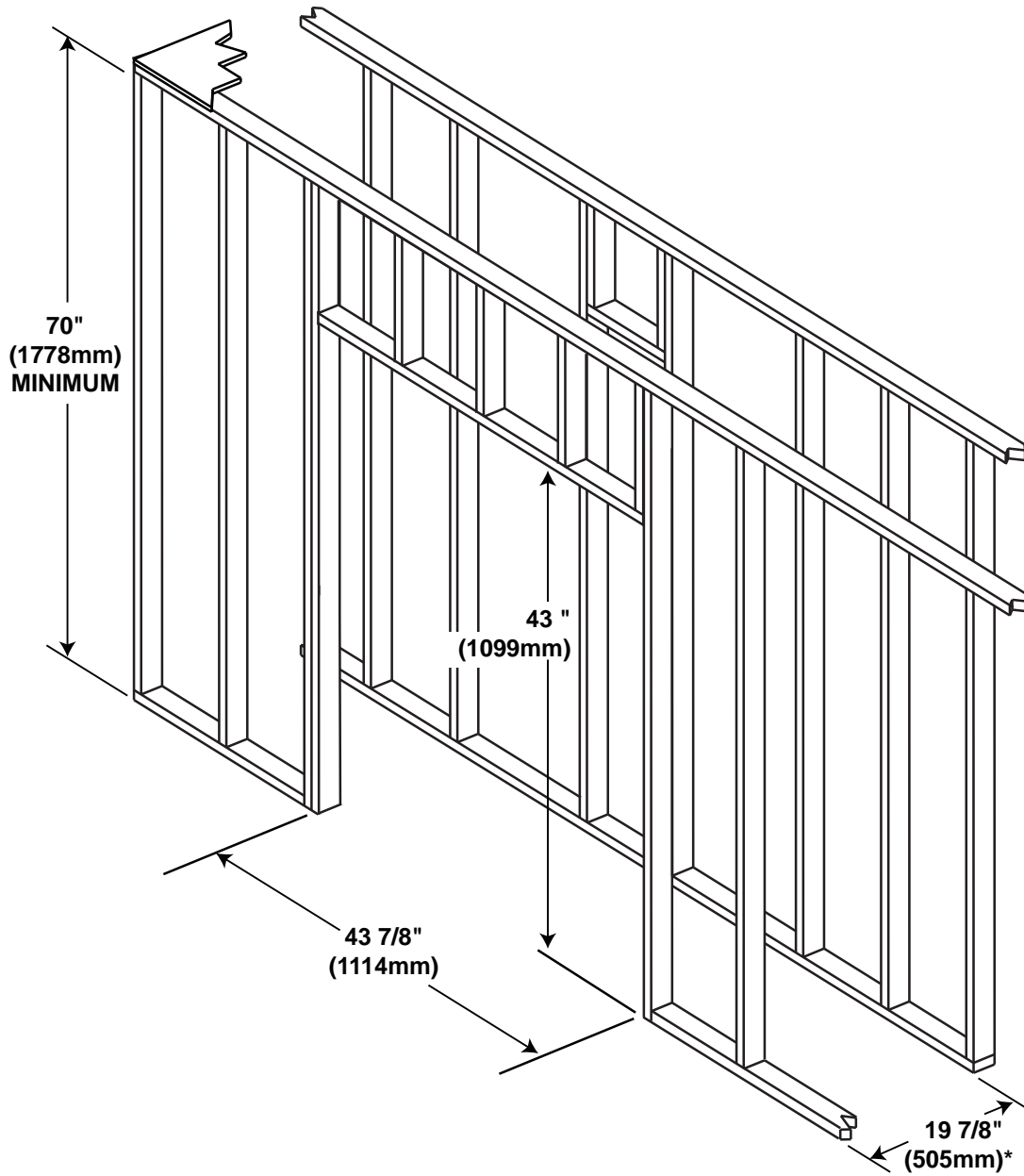



**INSIDE CHASE**

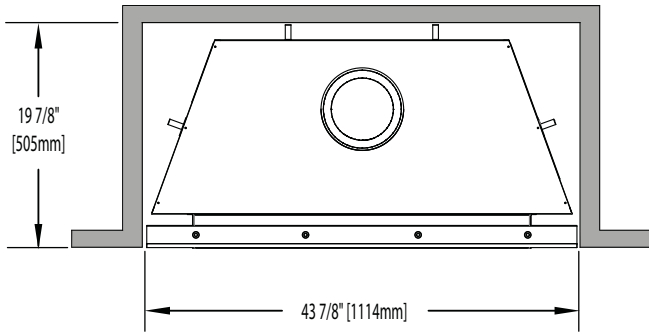

**OUTSIDE CHASE**

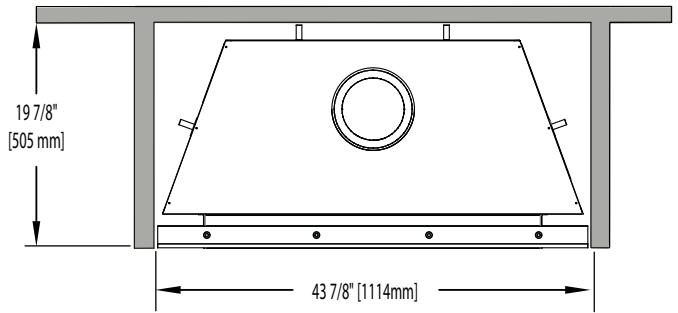

**CORNER CHASE**

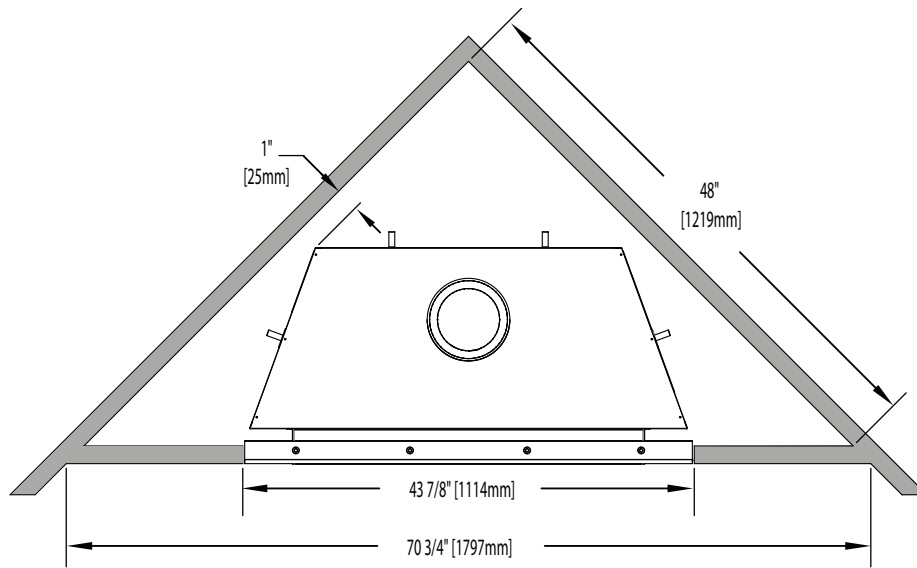

## 5.1 INSTALLING NON-COMBUSTIBLE BOARD

**! WARNING**

**A NON-COMBUSTIBLE FINISHING MATERIAL BORDER, SUCH AS BRICK, MARBLE, GRANITE, ETC. IS REQUIRED. FINISHING WITH JUST NON-COMBUSTIBLE BOARD TO THE SIDES AND TOP OF THE APPLIANCE IS NOT ALLOWED.**

**THE SURFACE ABOVE THE APPLIANCE GETS VERY HOT. IF PROPER FINISHING MATERIALS ARE NOT USED, CRACKING CAN OCCUR.**

With the frame assembly in place, use drywall screws to install the non-combustible board sides (1) and center (2).

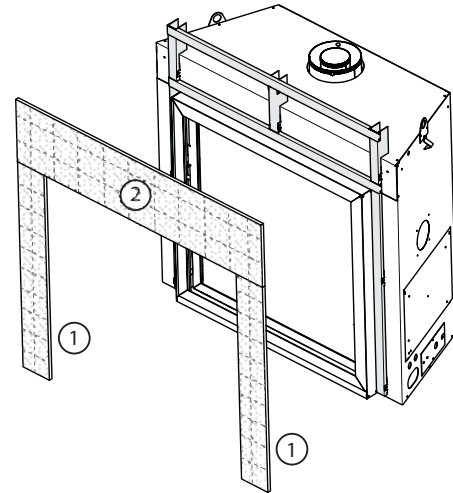
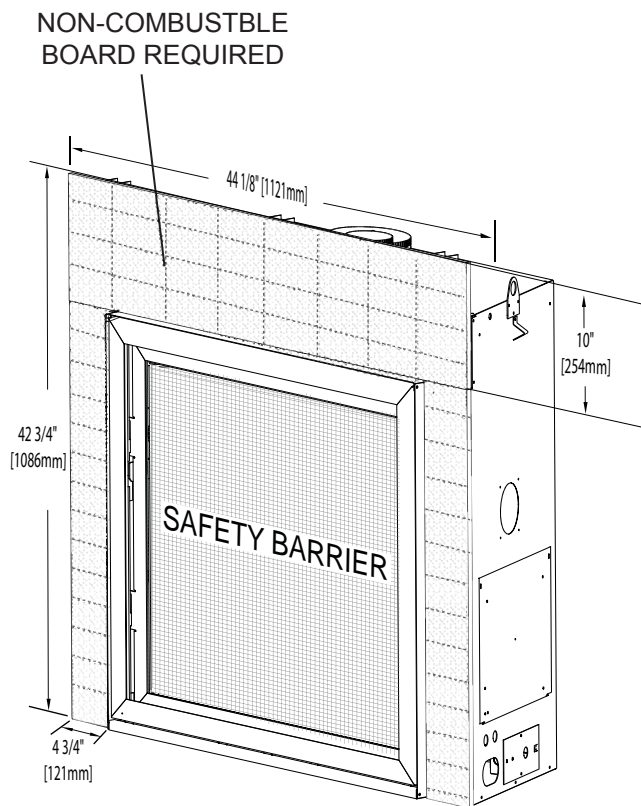

**NOTE: Avoid joints or grout lines aligning with non-combustible board seams.**

**Joint Compound where required**

Joint compounds such as Durabond 90 and tapes that are resilient to heat and cracking should be used when taping and mudding seams.

**Setting tiles and grouting**

We recommend you use tiles with a dry butt joint to be installed using a two-part mortar with an acrylic latex additive, such as Mapei Kerabond/Kerlastic, to allow for slight movement in the normal operation of the appliance.

If grout is used between the tiles, a polymer-based grout, such as Mapei Ultracolor plus, is recommended.

Depending on finishing material thickness, the frame assembly can be adjusted out from the unit by 1 1/2" (38mm), as shown below:

**NOTE:** Framing dimensions will vary depending on finishing material thickness. For recessed depths greater than 2" (51mm) refer to "NON-COMBUSTIBLE FINISHING MATERIAL" section.

EN

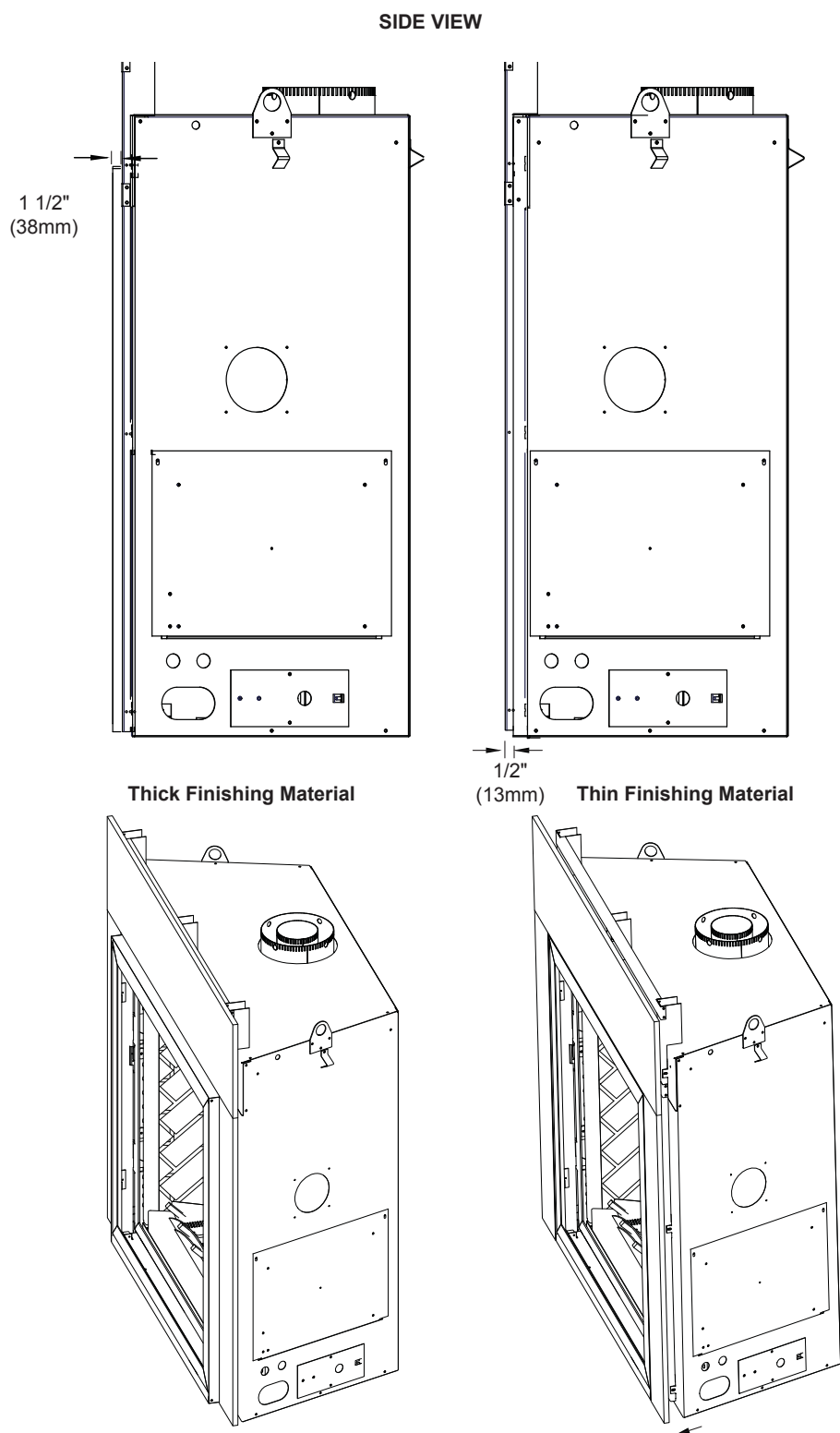

**NOTE:** If installing your non-combustible board directly to the unit, remove the steel framing members and discard. This is necessary for recessed applications greater than 1 1/2" (38mm) deep or for applications with recesses greater than 1 1/2" (38mm).

## 5.2 MINIMUM CLEARANCE TO COMBUSTIBLE ENCLOSURES

<b>! WARNING</b>
<b>RISK OF FIRE!</b>
<b>THE FRONT OF THE APPLIANCE MUST BE FINISHED WITH ANY NON-COMBUSTIBLE MATERIALS SUCH AS BRICK, MARBLE, GRANITE, ETC., PROVIDED THAT THESE MATERIALS DO NOT COVER THE APPLIANCE OPENING.</b>
<b>THE STEEL STUD FRAMING KITS WITH CEMENT BOARD PROVIDED MUST BE INSTALLED UNLESS RECESSING INTO NON-COMBUSTIBLE MATERIALS DEEPER THEN 1 1/2".</b>

**IMPORTANT:** The HDX35 requires a minimum inside enclosure height of 70" (1778mm), measured from the bottom of the appliance. For temperature requirements, this area must be left unobstructed. It is recommended that the enclosure be ventilated at the top and bottom to circulate the air.

**NOTE:** JOINT COMPOUNDS AND TAPES THAT ARE RESILIENT TO HEAT AND CRACKING SHOULD BE USED WHEN TAPING AND MUDDING SEAMS.

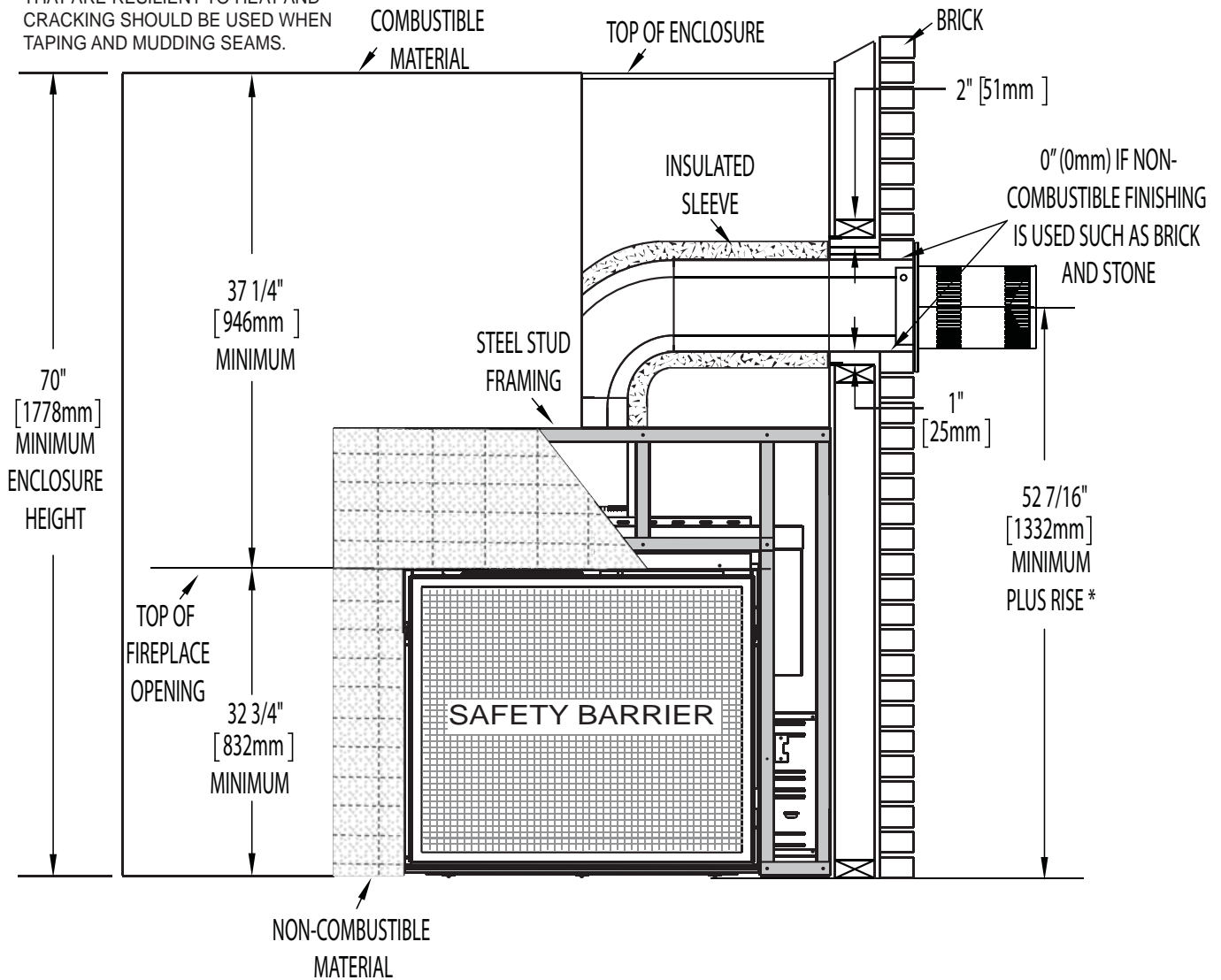

## 5.2.1 CLEARANCE TO COMBUSTIBLES ENCLOSURE WITHOUT ALCOVE

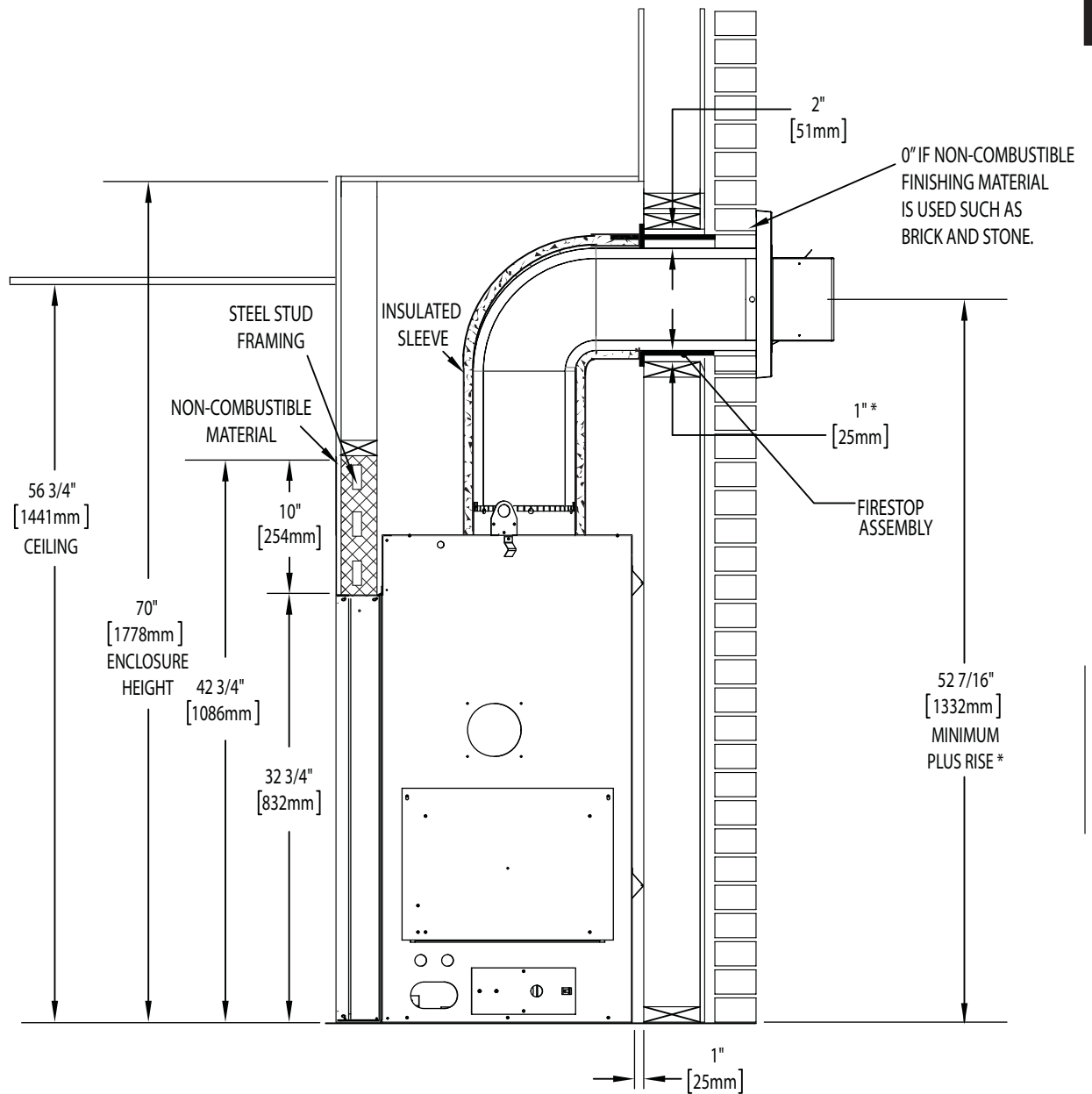

**IMPORTANT:** THE FIRESTOP ASSEMBLY PROVIDED MUST BE USED WHEN THE VENT PIPES PASS THROUGH ANY COMBUSTIBLE WALL, FLOOR OR CEILING.

## 5.2.2 ALCOVE CLEARANCE TO COMBUSTIBLES ENCLOSURE

EN

**NOTE:** When framing with an alcove the enclosure height must be 72" (1829mm) not 70" (1778mm)

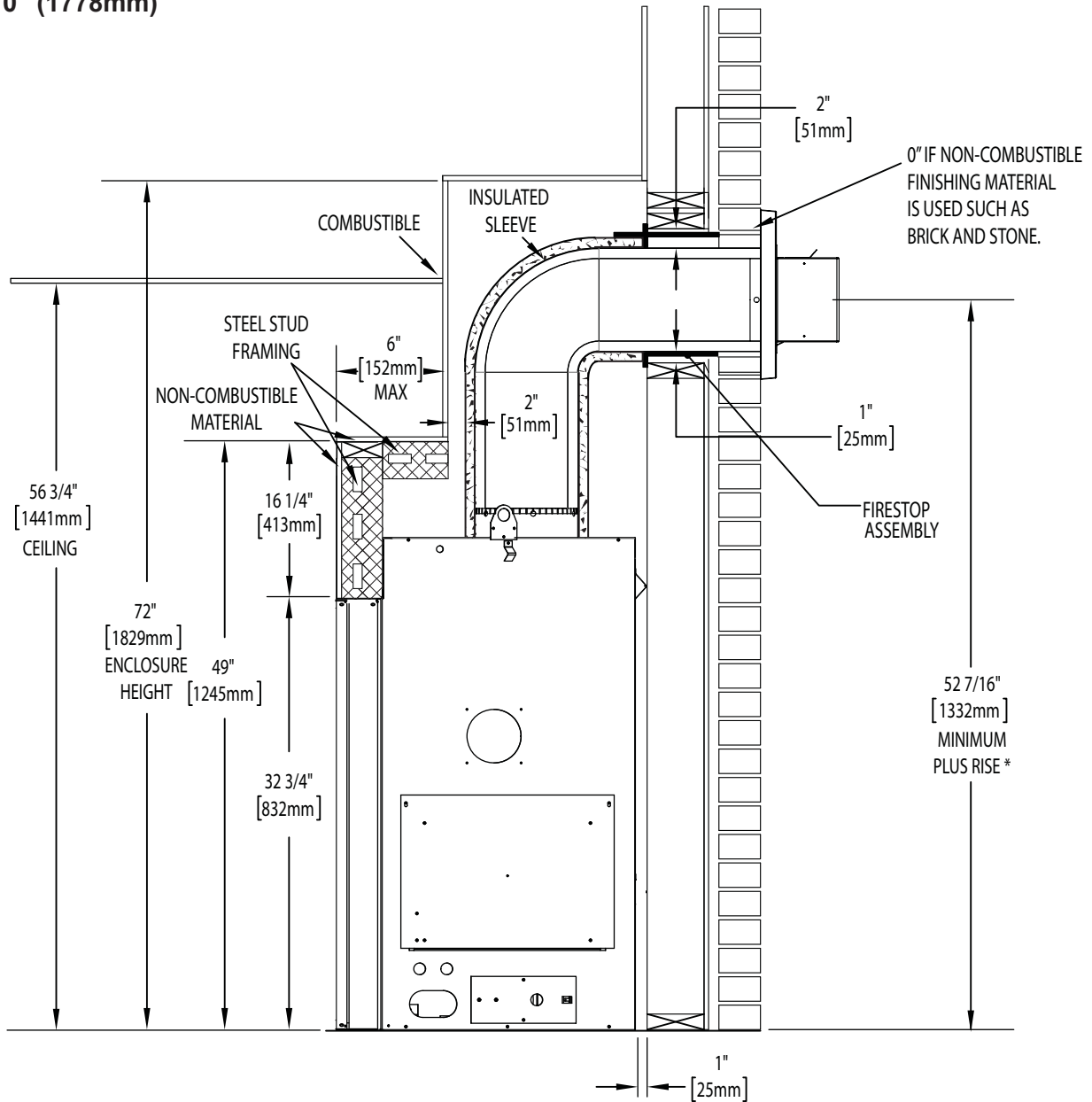

\* See venting section.

**IMPORTANT:** THE FIRESTOP ASSEMBLY PROVIDED MUST BE USED WHEN THE VENT PIPES PASS THROUGH ANY COMBUSTIBLE WALL, FLOOR OR CEILING.

5.3 MINIMUM COMBUSTIBLE MANTEL CLEARANCES

EN

**! WARNING**

**RISK OF FIRE, MAINTAIN ALL SPECIFIED AIR SPACE CLEARANCES TO COMBUSTIBLES. FAILURE TO COMPLY WITH THESE INSTRUCTIONS MAY CAUSE A FIRE OR CAUSE THE APPLIANCE TO OVERHEAT. ENSURE ALL CLEARANCES (I.E. BACK, SIDE, TOP, VENT, MANTEL, FRONT, ETC.) ARE CLEARLY MAINTAINED.**

**WHEN USING PAINT OR LACQUER TO FINISH THE MANTEL, THE PAINT OR LACQUER MUST BE HEAT RESISTANT TO PREVENT DISCOLOURATION.**

73.1

Combustible mantel clearance height from the appliance can vary according to the mantel depth. Use the graph to help evaluate the clearance needed.

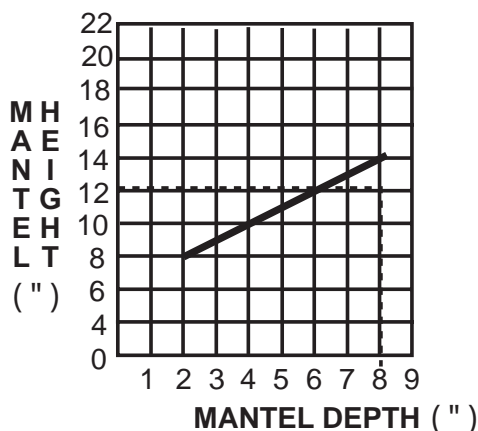

MANTEL DIMENSIONS		
Ref	Height	Depth
A	32 3/4" (832mm)	
B	8" (203mm)	2" (51mm)
C	10" (254mm)	4" (102mm)
D	12" (305mm)	6" (152mm)
E	14" (356mm)	8" (203mm)

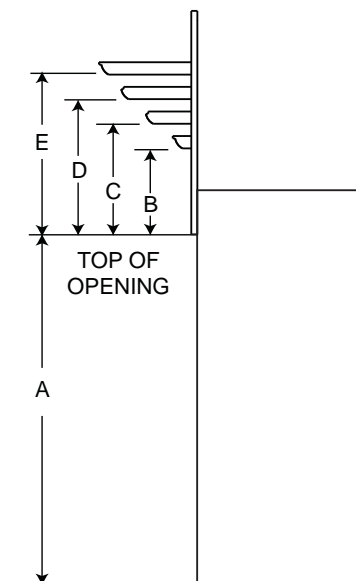



## 5.4 NON-COMBUSTIBLE FINISHING MATERIAL

EN

**WARNING:** The appliance opening may be recessed in non-combustible facing material provided it does not project more than 2" (51mm) past the face of the appliance. If greater projections are desired, increase the clearance to the sides and top by 2" (51mm) for every additional 1" (25mm) of projection. If using an optional surround, then 2" (51mm) clearance from the surround is required before projecting out a maximum 2" (51mm). If greater projections are desired, increase the clearance from the surround by 2" (51mm) for every 1" (25mm) of additional projection.

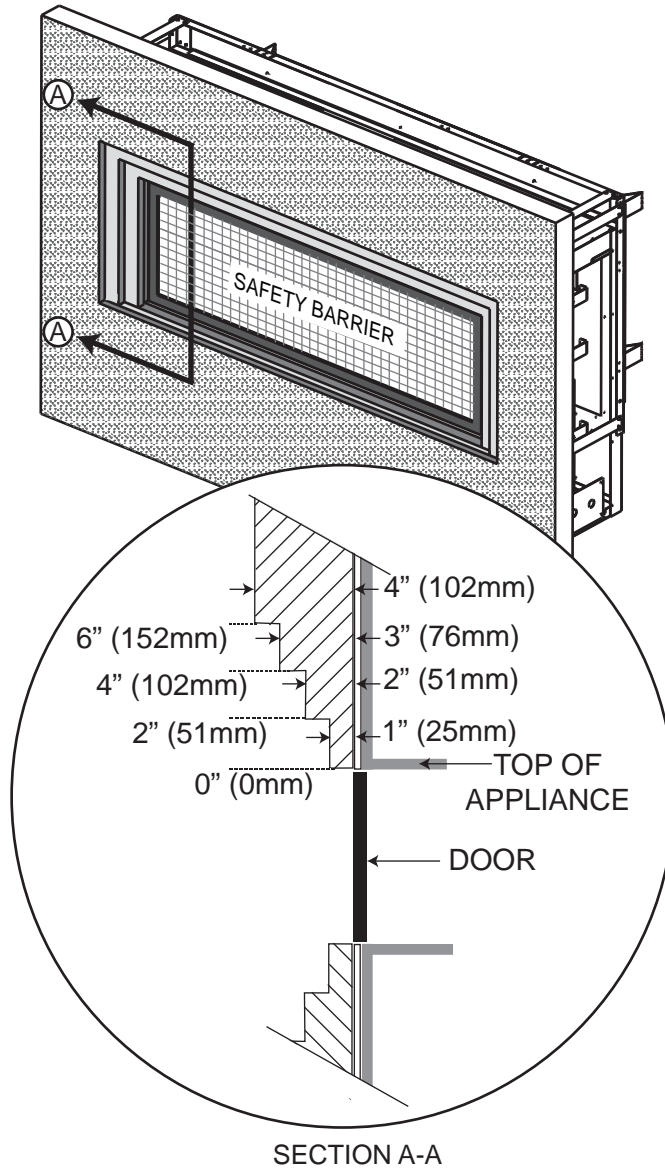

71.5C

## 6.0 FINISHING

<b>! WARNING</b>
<b>RISK OF FIRE!</b>
<b>NEVER OBSTRUCT THE FRONT OPENING OF THE APPLIANCE.</b>
<b>THE FRONT OF THE APPLIANCE MUST BE FINISHED WITH ANY NON-COMBUSTIBLE MATERIALS SUCH AS BRICK, MARBLE, GRANITE, ETC., PROVIDED THAT THESE MATERIALS DO NOT GO BELOW THE SPECIFIED DIMENSION AS ILLUSTRATED.</b>
<b>DO NOT STRIKE, SLAM OR SCRATCH GLASS. DO NOT OPERATE APPLIANCE WITH GLASS REMOVED, CRACKED, BROKEN OR SCRATCHED.</b>
<b>FACING AND/OR FINISHING MATERIAL MUST NEVER OVERHANG INTO THE APPLIANCE OPENING.</b>
<b>THE GLASS DOOR ASSEMBLY IS DESIGNED TO PIVOT FORWARD WHEN RELIEVING EXCESS PRESSURE THAT MIGHT OCCUR. FINISHING OR OTHER MATERIALS MUST NOT BE LOCATED IN THE OPENING SURROUNDING THE DOOR AS THIS WILL INTERFERE WITH THE DOORS ABILITY TO RELIEVE THE PRESSURE.</b>

72.6

### 6.1 SAFETY BARRIER REMOVAL / INSTALLATION

<b>! WARNING</b>
<b>GLASS MAY BE HOT, DO NOT TOUCH GLASS UNTIL COOLED.</b>
<b>THE DOOR LATCHES ARE PART OF A SAFETY RELIEF SYSTEM AND MUST BE PROPERLY ENGAGED. DO NOT OPERATE THE APPLIANCE WITH LATCHES DISENGAGED.</b>
<b>FACING AND/OR FINISHING MATERIALS MUST NOT INTERFERE WITH AIR FLOW THROUGH AIR OPENINGS, LOUVRES OPENINGS, OPERATION OF LOUVRES OR DOORS OR ACCESS FOR SERVICE. OBSERVE ALL CLEARANCES WHEN APPLYING COMBUSTIBLE MATERIALS.</b>
<b>BEFORE DOOR IS REMOVED TURN THE APPLIANCE OFF AND WAIT UNTIL APPLIANCE IS COOL TO THE TOUCH. DOORS ARE HEAVY AND FRAGILE SO HANDLE WITH CARE.</b>

75.1

A barrier designed to reduce the risk of burns from the hot viewing glass is provided with the appliance and must be installed.

- A. There are 4 hanging tabs securing the safety barrier onto the door. The tabs are on the right and left sides of the door.
- B. Lift up and pull the safety barrier away from the unit to remove it from the slots in the main door, refer to Figure 1.
- C. Reverse this process to install the safety barrier back onto the unit.

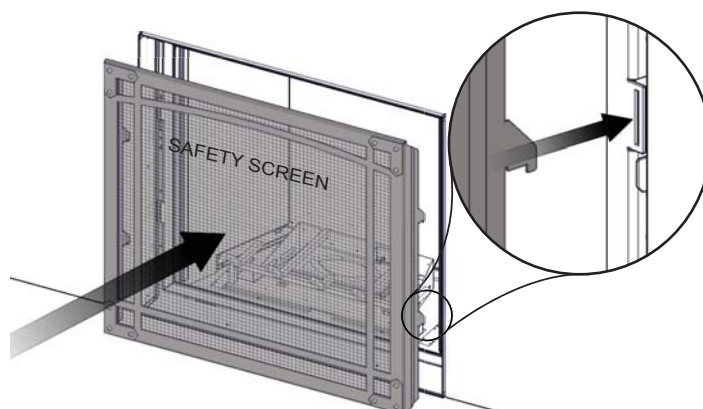

## 6.2 LATCH DOOR REMOVAL / INSTALLATION

- A. There are 4 spring latches securing the main glass door, 2 of those latches are across the top and 2 along the bottom. To access these latches ensure the screen is removed.
- B. Using the tool provided, pull the latch forward and upwards / downwards, out of the slot in the door, as shown. Repeat 3 times.
- C. When all 4 latches have been released slide the door forward and lift off of the 2 door slides.
- D. Reverse this process to install the door.

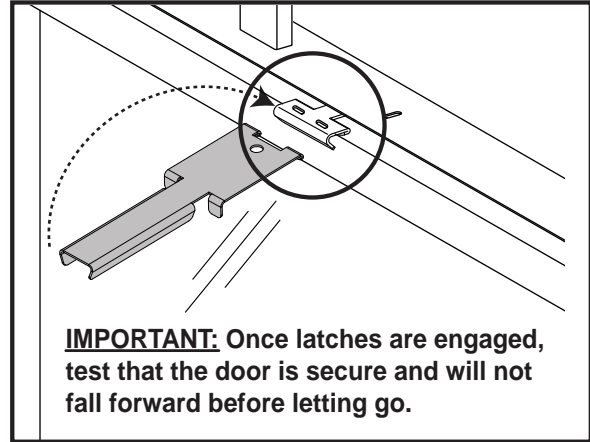

THE 4 LATCHES ARE SHOWN IN THE ILLUSTRATION BELOW.

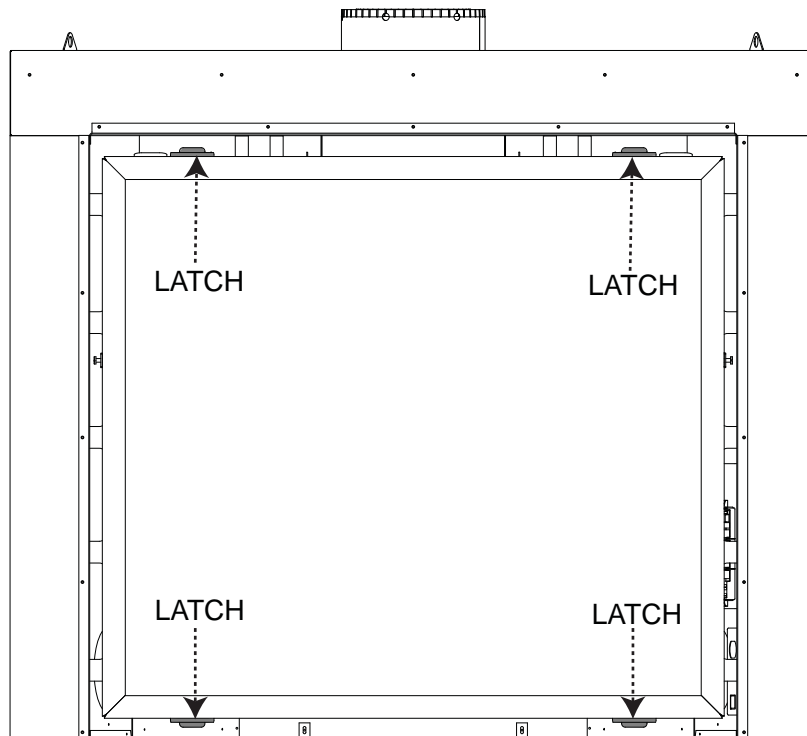

### 6.3 GLASS DOOR REMOVAL / INSTALLATION

- A. Release the 4 door latches from the top and bottom of the door. Refer to 'LATCH DOOR REMOVAL / INSTALLATION' section.
- B. Slide the glass door forward from the unit. It will sit on the door slides attached to the unit, refer to Figure 1.
- C. Lift the glass door off the door slides and away from the unit.
- D. Reverse this process to install the screen back onto the unit.

FIG. 1

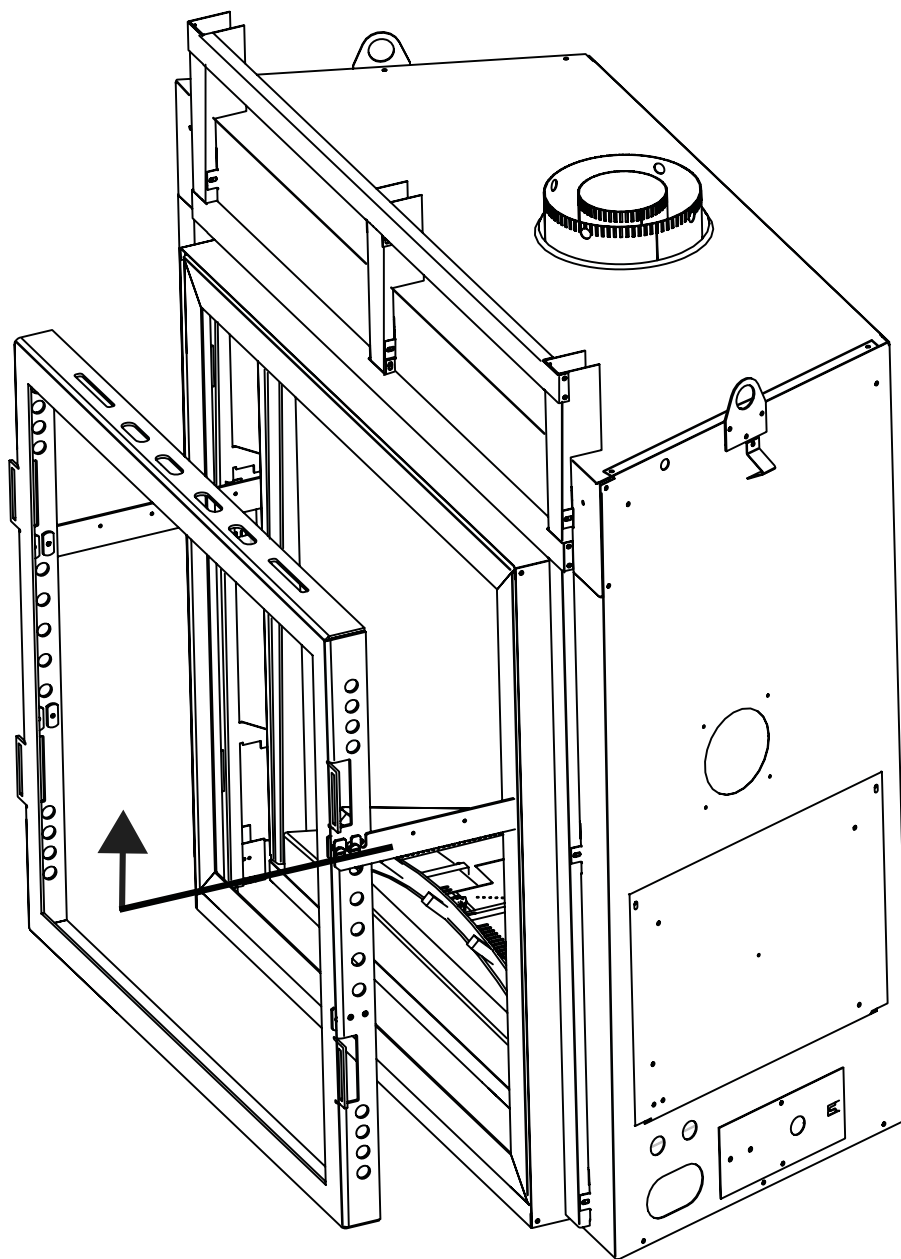

## 6.4 BURNER INSTALLATION

See instructions accompanying burner assembly (sold separately).

## 6.5 LOGO PLACEMENT

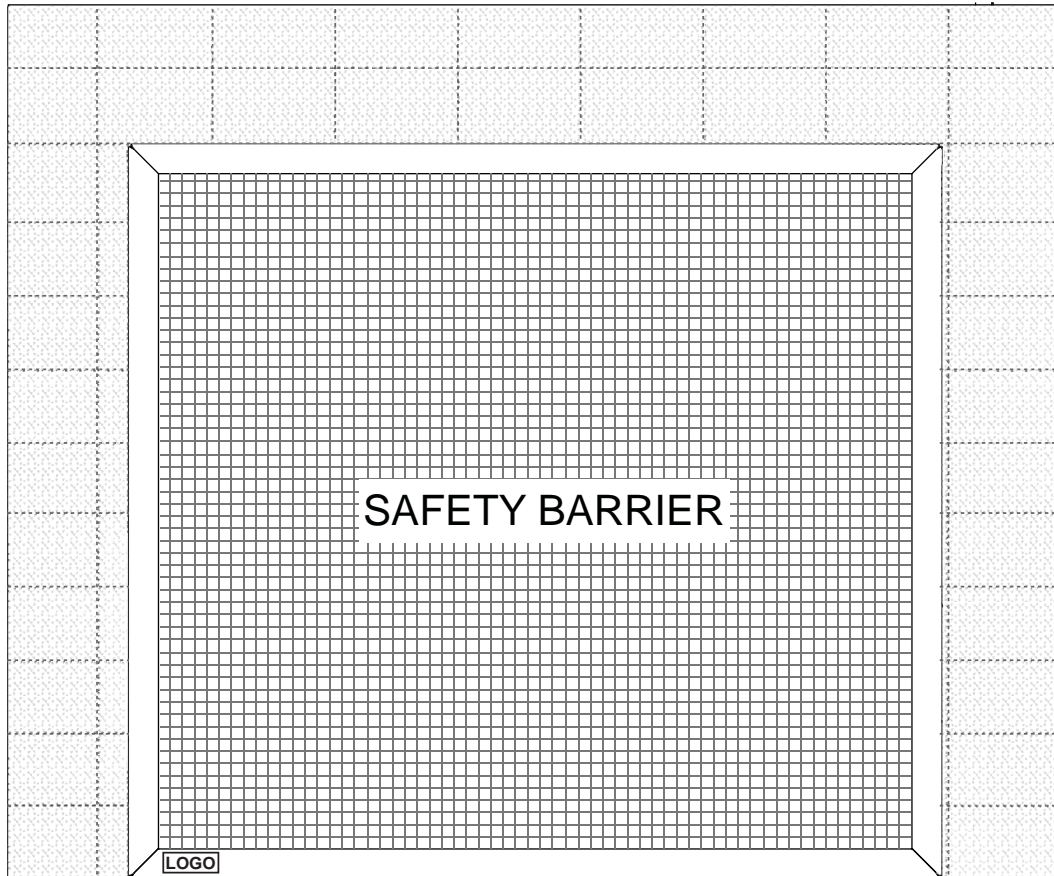

## 7.0 ELECTRICAL INFORMATION

<b>! WARNING</b>
<b>ENSURE TO UNPACK ALL LOOSE MATERIALS FROM INSIDE THE FIREBOX PRIOR TO HOOKING UP THE GAS AND ELECTRICAL SUPPLY.</b>
<b>IF YOUR APPLIANCE IS SUPPLIED WITH A REMOTE ENSURE THE REMOTE RECEIVER IS IN THE "OFF" POSITION PRIOR TO HOOKING UP THE GAS AND ELECTRICAL SUPPLY TO THE APPLIANCE.</b>
<b>FOR SAFE AND PROPER OPERATION OF THE APPLIANCE, FOLLOW THE VENTING INSTRUCTIONS EXACTLY.</b>
<b>ALL INNER EXHAUST AND OUTER INTAKE VENT PIPE JOINTS MAY BE SEALED USING EITHER RED RTV HIGH TEMP SILICONE SEALANT W573-0002 (NOT SUPPLIED) OR BLACK HIGH TEMP MILL PAC W573-0007 (NOT SUPPLIED) WITH THE EXCEPTION OF THE APPLIANCE EXHAUST FLUE COLLAR WHICH MUST BE SEALED USING MILL PAC.</b>
<b>IF USING PIPE CLAMPS TO CONNECT VENT COMPONENTS, 3 SCREWS MUST ALSO BE USED TO ENSURE THE CONNECTION CANNOT SLIP OFF.</b>
<b>DO NOT CLAMP THE FLEXIBLE VENT PIPE.</b>
<b>RISK OF FIRE, EXPLOSION OR ASPHYXIATION. IMPROPER SUPPORT OF THE ENTIRE VENTING SYSTEM MAY ALLOW VENT TO SAG AND SEPARATE. USE VENT RUN SUPPORTS AND CONNECT VENT SECTIONS PER INSTALLATION INSTRUCTIONS.</b>
<b>RISK OF FIRE, DO NOT ALLOW LOOSE MATERIALS OR INSULATION TO TOUCH THE VENT PIPE. REMOVE INSULATION TO ALLOW FOR THE INSTALLATION OF THE ATTIC SHIELD AND TO MAINTAIN CLEARANCES TO COMBUSTIBLES.</b>

68.2B

### 7.1 HARD WIRING CONNECTION

#### **It is necessary to hard wire this appliance.**

Permanently framing the appliance with an enclosure, requires the appliance junction box to be hard wired. This appliance must be electrically connected and grounded in accordance with local codes. In the absence of local codes, use the current CSA C22.1 Canadian electrical code in Canada or the ANSI/NFPA 70-1996 national electrical code in the United States.

### 7.2 RECEPTACLE WIRING DIAGRAM

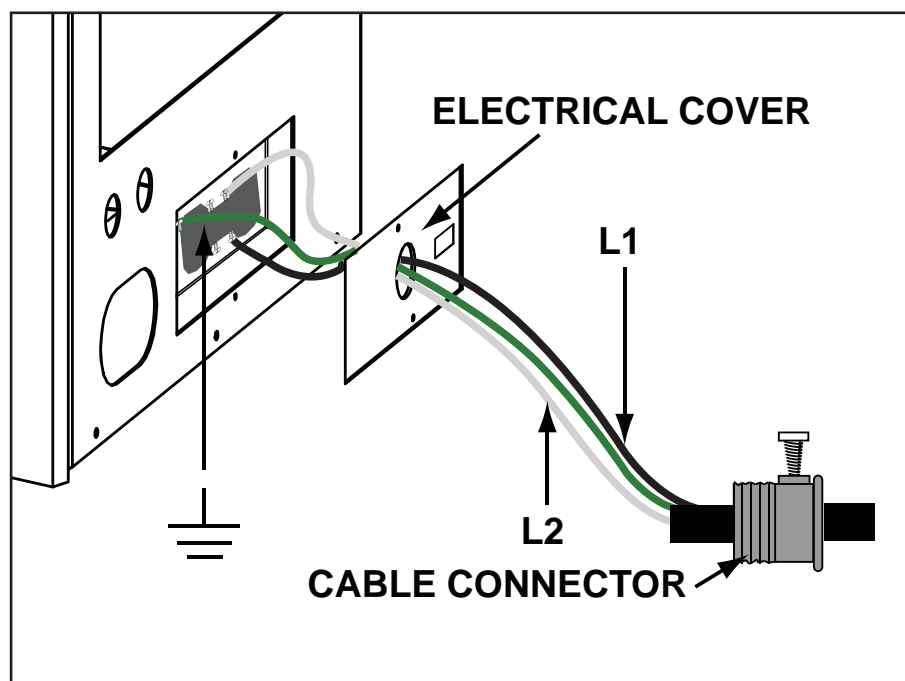



### 7.3 BATTERY HOLDER INSTALLATION

- A. The battery holder must be located within 8 feet of this side of the appliance and must be accessible for programming the remote.
- B. Install 4 AA batteries, ensure that the positive and negative ends correspond with those identified in the battery holder.
- C. Install the battery holder into a standard electrical switch box. Determine an appropriate location and install the electrical box.

**NOTE:** Ensure the 3 position slider switch is in the “REMOTE” position (middle).

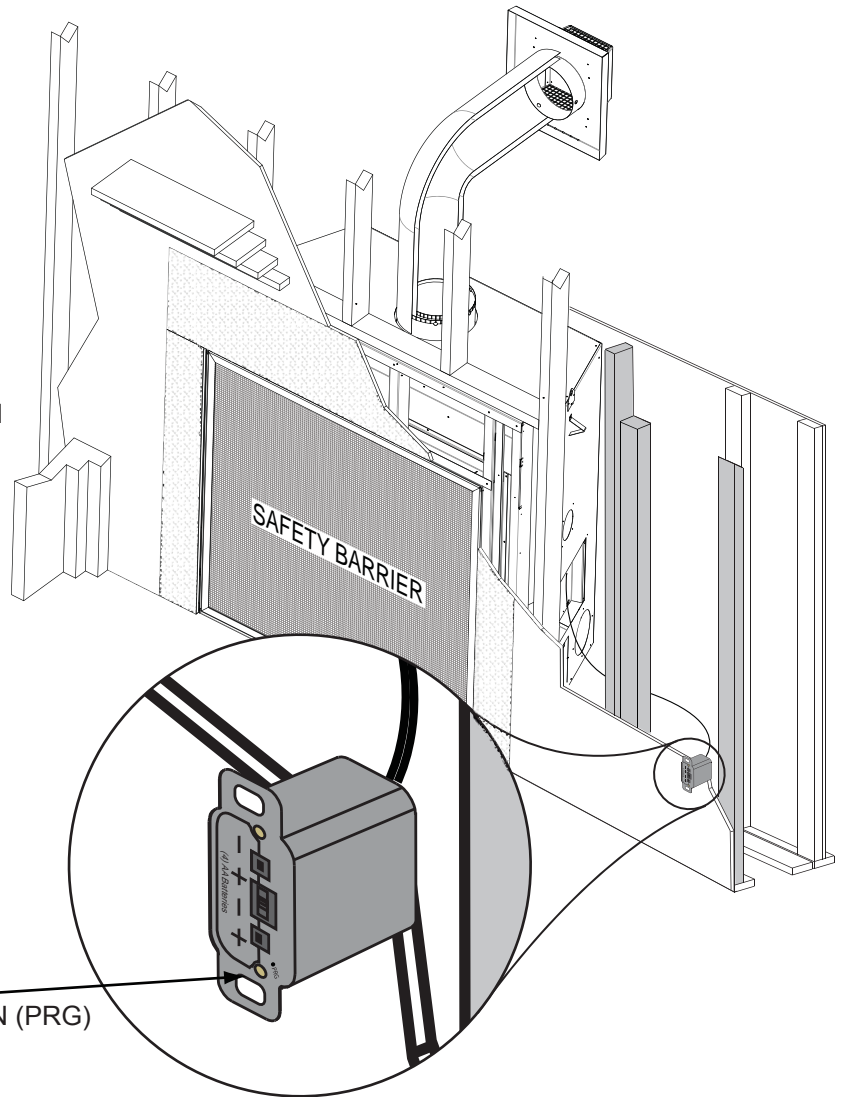

RESET/PROGRAM BUTTON (PRG)



7.4 WIRING DIAGRAM

**! WARNING**

**DO NOT WIRE 110 VOLTS TO THE VALVE OR WALL SWITCH.**

EN

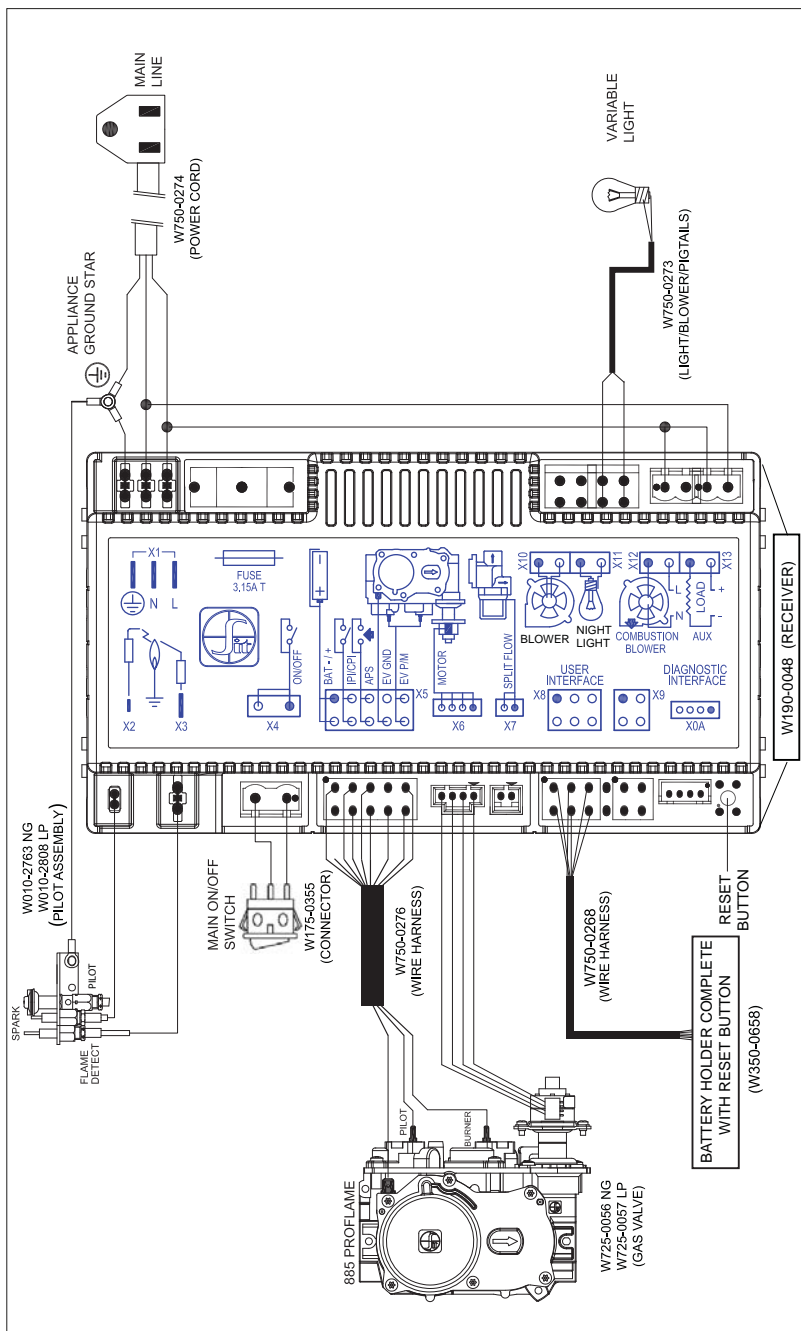

**NOTE:** This appliance is equipped with a three-prong (grounding) plug for protection against shock hazard and should be plugged directly into a properly grounded three-prong receptacle. Do not cut or remove the grounding prong from the plug.

## 8.0 OPERATION

### 8.1 GENERAL TRANSMITTER LAYOUT

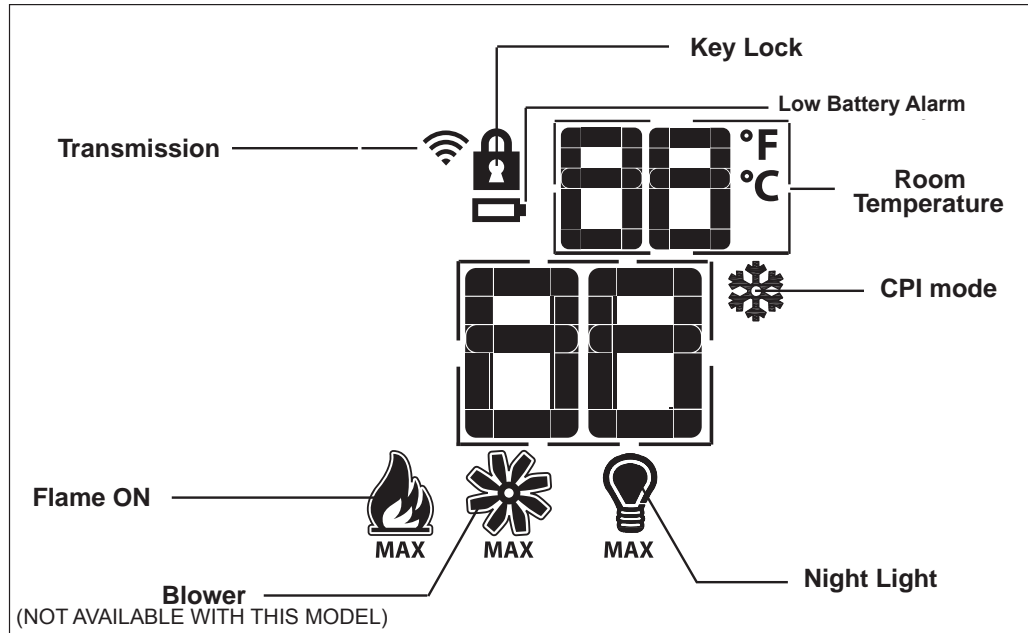

### 8.2 INITIALIZING THE TRANSMITTER/BATTERY HOLDER FOR THE FIRST TIME

- Install the 4 AA batteries into the Proflame 2 battery holder, note the polarity of the batteries and insert as indicated on the cover (+/-).
- Ensure the 3 position slider switch is switched to the "REMOTE" position (middle position).
- Press the reset/programming button, use a small object such as a paper clip in order to reach the button marked PRG, as shown in the illustration below.
- The battery holder will beep 3 times to indicate that it's ready to synchronize with the transmitter.
- Install the 3 AAA batteries into the transmitter, as shown in the photograph below, then press the ON button, The battery holder will beep 4 times to indicate that the transmitter's command is accepted.

**NOTE:** THE INITIALIZING PROCESS MUST BE COMPLETED WITHIN 10 SECONDS OF PRESSING THE RESET/PROGRAM BUTTON (PRG).

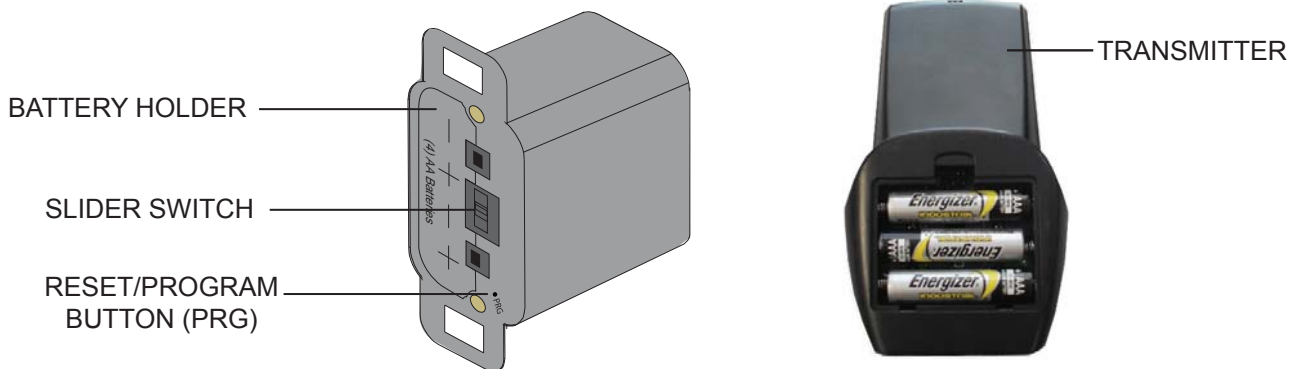

### 8.3 TEMPERATURE DISPLAY

- A. With the system in the "OFF" position, press the Temperature Key and the Mode Key at the same time to change from degrees F to C.
- B. Look at the LCD screen on the Transmitter to verify that a C or F is visible to the right of the Room Temperature display.

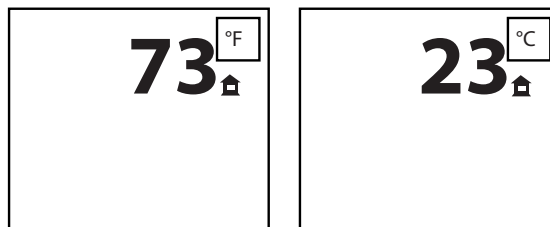

35.5A

### 8.4 SMART THERMOSTAT

The Smart Thermostat function adjusts the flame height according to the difference between the set temperature and the actual room temperatures. As the room temperature gets closer to the set point the Smart Function will automatically adjust the flame down.

- Press the thermostat key until the word "SMART" appears to the right of the temperature bulb graphic.
- To adjust the set temperature, press the Up/Down arrow keys until the desired set temperature is displayed on the LCD screen at the Transmitter.

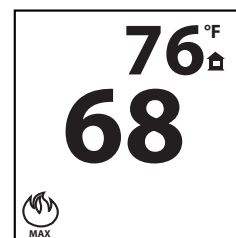

35.7

### 8.5 ROOM TEMPERATURE

The remote transmitter can operate as a room thermostat.

The thermostat can be set to a desired temperature to control the comfort level in the room.

- Press the Thermostat Key. The LCD display on the Transmitter will show that the room is "ON" and the set temperature is now displayed.
- To adjust the set temperature, press the Up/Down Arrow Keys until the desired set temperature is displayed on the LCD screen of the Transmitter.

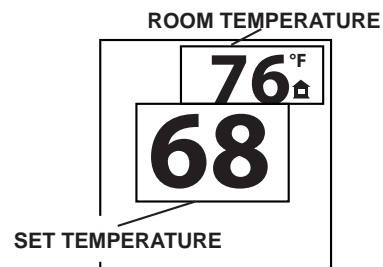

35.6

### 8.6 FLAME HEIGHT

The remote control has six (6) flame levels. With the system on and the flame level at the maximum, press the Down Arrow Key once and it will reduce the flame height by one step until the flame is turned off. The Up Arrow Key will increase the flame height each time it is pressed. If the Up Arrow Key is pressed while the system is on but the flame is off, the flame will come on the high position. A single "beep" will confirm reception of the command.

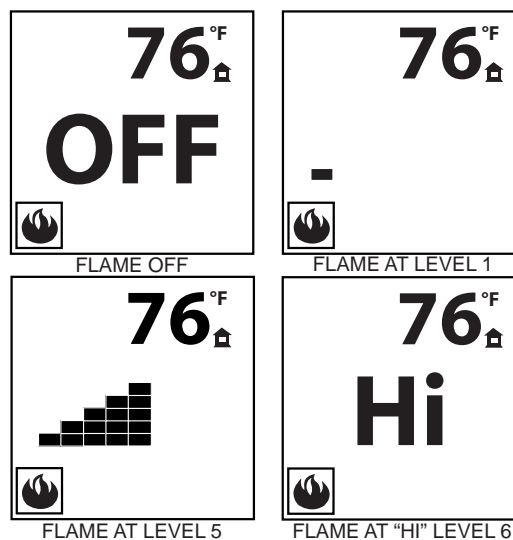

35.8A

## 8.7 NIGHT LIGHT DIMMER CONTROL

The auxiliary function controls the Night Light™ with dimmable control.

- A. Use the Mode Key to guide you to the Night Light icon.
- B. The intensity of the output can be adjusted through 6 levels. Use the UP/DOWN arrow keys to adjust the output level. A single beep will confirm reception of the command.

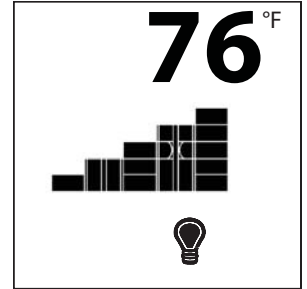
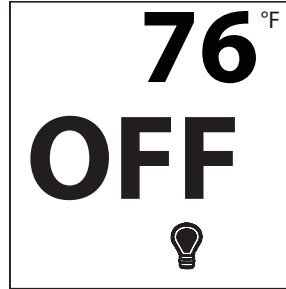



---

 35.21

## 8.8 CONTINUOUS PILOT / INTERMITTENT PILOT (CPI / IPI) SELECTION

- A. Use the Mode Key to guide you to the CPI mode icon. Transmitter in the OFF position.
- B. Press the UP/DOWN to switch between IPI and CPI modes. A single BEEP will confirm reception of the command.

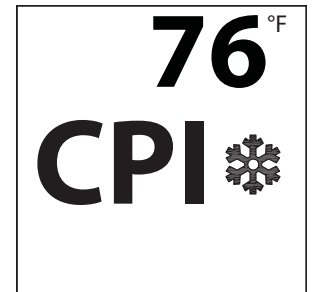
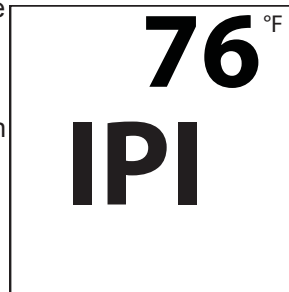
**Note:** If the system is equipped with a CPI/IPI toggle switch, set the CPI/IPI to CPI position to enable remote CPI operation. If the switch is set to IPI then it will only work in IPI regardless of what is set on the remote control handset.



---

 35.22

## 8.9 KEY LOCK

This function will lock the keys to avoid unsupervised operation.

- A. Press the MODE and UP keys at the same time.
- B. To de-activate this function, press the MODE and UP keys at the same time.



---

 35.10A

## 8.10 LOW BATTERY / MANUAL BYPASS

The life span of the remote batteries depends on various factors: quality of the batteries, the number of ignitions, the number of changes to the room thermostat set point, etc.

When the transmitter batteries are low, a Battery Icon will appear on the LCD display before all battery power is lost. When the batteries are replaced this icon will disappear.

Not applicable when plugged into 110V.

When the batteries are low, no “beep” will be emitted from the receiver when it receives an ON/OFF command. This is an alert for the receiver that there’s low battery. When the batteries are replaced the “beep” will be emitted from the receiver when the ON/OFF key is pressed.

If the batteries in the battery holder or transmitter are low, the appliance can be turned on manually by sliding the three position slider switch on the battery holder to the “ON” position. This will bypass the remote control feature and the appliance main burner will come on. Likewise, if you want to manually turn the appliance off, slide the switch to the ‘OFF’ position.

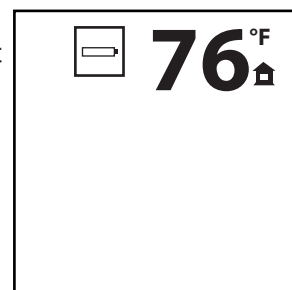

---

35.23

## 9.0 OPERATING INSTRUCTIONS

### **! WARNING**

**IF YOU DO NOT FOLLOW THESE INSTRUCTIONS EXACTLY, A FIRE OR EXPLOSION MAY RESULT CAUSING PROPERTY DAMAGE, PERSONAL INJURY OR LOSS OF LIFE.  
NEVER LEAVE CHILDREN OR OTHER AT RISK INDIVIDUALS ALONE WITH THE APPLIANCE.**

**ALWAYS LIGHT THE PILOT WHETHER FOR THE FIRST TIME OR IF THE GAS SUPPLY HAS RUN OUT WITH THE GLASS DOOR OPENED OR REMOVED.**

Ensure that a continuous gas flow is at the burner before installing the door. When lit for the first time, the appliance will emit an odor for a few hours. This is a normal temporary condition caused by the “burn-in” of paints and lubricants used in the manufacturing process and will not occur again. After extended periods of non-operation such as following a vacation or a warm weather season, the appliance may emit a slight odor for a few hours. This is caused by dust particles in the heat exchanger burning off. In both cases, open a window to sufficiently ventilate the room.



#### FOR YOUR SAFETY READ BEFORE LIGHTING:

- A. This appliance is equipped with an ignition device which automatically lights the pilot. Do not try to light by hand.
- B. Before operating smell all around the appliance area for gas and next to the floor because some gas is heavier than air and will settle on the floor.
- C. Do not use this appliance if any part has been under water. Immediately call a qualified service technician to inspect the appliance and replace any part of the control system and any gas control which has been under water.

#### WHAT TO DO IF YOU SMELL GAS:

- Turn off all gas to the appliance.
- Open windows.
- Do not try to light any appliance.
- Do not touch any electric switch; do not use any phone in your building.
- Immediately call your gas supplier from a neighbor's phone. Follow the gas supplier's instructions.
- If you cannot reach your gas supplier, call the fire department.

#### LIGHTING INSTRUCTIONS

- A. Stop! Read the above safety information on this label.
- B. Remove batteries from transmitter.
- C. Turn off all electric power to the appliance.
- D. This appliance is equipped with an ignition device which automatically lights the pilot. Do not try to light the pilot by hand.
- E. Open the glass door.
- F. Turn manual shutoff valve clockwise  to off. Located behind the access panel.
- G. Wait five (5) minutes to clear out any gas. If you smell gas including near the floor, **STOP!** Follow “B” in the above safety information on this label. If you don't smell gas go to the next step.
- H. Turn manual shutoff valve counter-clockwise  to on.
- I. Close the glass door.
- J. Turn on all electric power to the appliance and re-install batteries into the transmitter.
- K. Push the “ON” button on the transmitter. You should here an audible beep from the receiver which indicates communication. (Refer to Appliance Operations for remote activation).

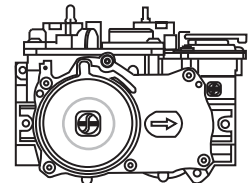

#### TO TURN OFF GAS

- A. Turn off all electric power to the appliance if service is to be performed.
- B. Access door inside the firebox must be removed to access the manual shutoff valve.
- C. If alternate shut-off valve was installed it can be shutoff instead of going through the appliance to access the appliance shut off valve.

## 9.1 RESTRICTING VERTICAL VENTS

Vertical installations may display a very active flame. If this appearance is not desirable, the vent exit must be restricted using a restrictor vent kit. Refer to "ACCESORIES" in the "REPLACEMENTS" section for the appropriate kit. This will reduce the velocity of the exhaust gases, slowing down the flame pattern and creating a more traditional gentle flame appearance. Specific instructions are included with the kit.

77.3

## 9.2 PILOT BURNER ADJUSTMENT

Adjust the pilot screw to provide properly sized flame. Turn in a clockwise direction to reduce the gas flow.

### **Check Pressure Readings:**

Inlet pressure can be checked by turning screw (A) counter-clockwise 2 or 3 turns and then placing pressure gauge tubing over the test point. Gauge should read as described on the chart below. Check that main burner is operating on "HI".

Outlet pressure can be checked the same as above using screw (B). Gauge should read as described on the chart below. Check that main burner is operating on "HI".

**AFTER TAKING PRESSURE READINGS, BE SURE TO TURN SCREWS CLOCKWISE FIRMLY TO RESEAL. DO NOT OVERTORQUE.**

Leak test with a soap and water solution.

Prior to pilot adjustment, ensure that the pilot assembly has not been painted. If overspray or painting of the pilot assembly has occurred remove the paint from the pilot assembly, or replace. Fine emery cloth or sandpaper can be used to remove the paint from the pilot hood, electrode and flame sensor.

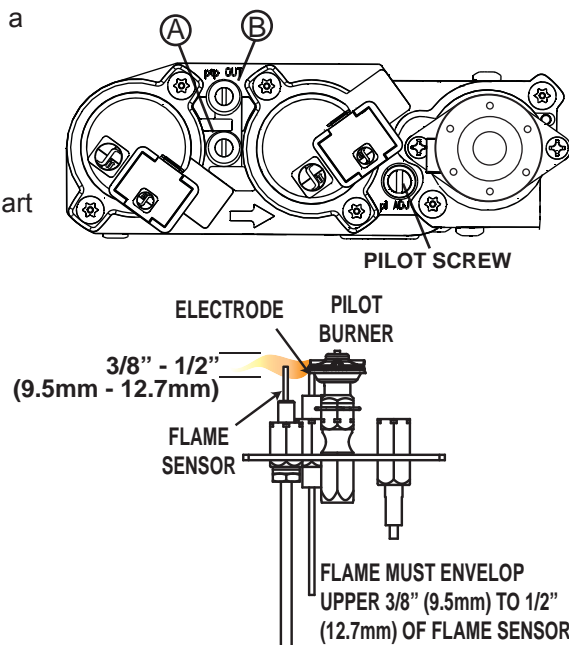

Pressure	Natural Gas (inches)	Natural Gas (millibars)	Propane (inches)	Propane (millibars)
Inlet	7" (MIN. 4.5")	17.4mb (MIN. 11.2mb)	13" (MIN. 11")	32.4mb (MIN. 27.4mb)
Outlet	3.5"	8.7mb	10"	24.9mb

39.1C



### 9.3 VENTURI ADJUSTMENT

This appliance has an air shutter that has been factory set open according to the chart below:

Regardless of venturi orientation, closing the air shutter will cause a more yellow flame, but can lead to carboning. Opening the air shutter will cause a more blue flame, but can cause flame lifting from the burner ports. The flame may not appear yellow immediately; allow 15 to 30 minutes for the final flame colour to be established.

**AIR SHUTTER ADJUSTMENT MUST ONLY BE DONE BY A QUALIFIED INSTALLER!**

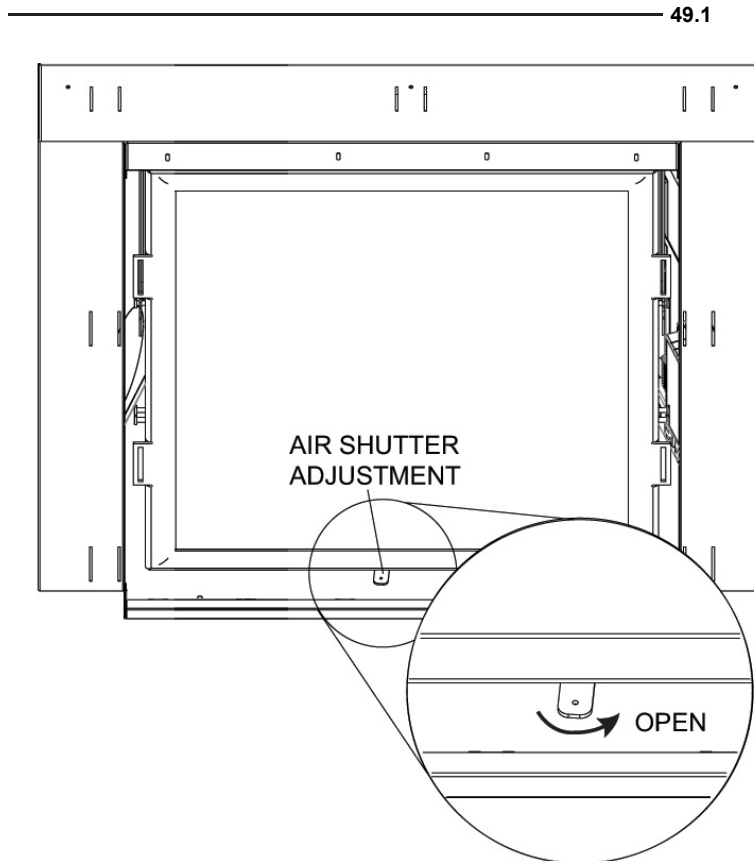

HDX35		
NG	1/4" (0.6mm) GLASS	1/4" (0.6mm) LOGS
LP	3/4" (1.9mm) GLASS	1/2" (1.3mm) LOGS

MAXIMUM INPUT RATE	
NG	35,000 BTU/HR
LP	35,000 BTU/HR

### 9.4 FLAME CHARACTERISTICS

It's important to periodically perform a visual check of the pilot and burner flames. Compare them to the illustration provided. If any flames appear abnormal call a service person.

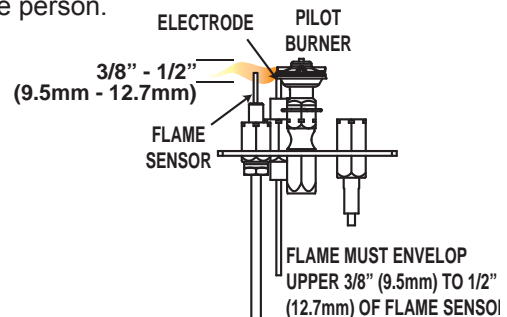

## 10.0 MAINTENANCE

**! WARNING****TURN OFF THE GAS AND ELECTRICAL POWER BEFORE SERVICING THE APPLIANCE.****APPLIANCE MAY BE HOT, DO NOT SERVICE UNTIL APPLIANCE HAS COOLED.****DO NOT USE ABRASIVE CLEANERS.****DO NOT PAINT THE PILOT ASSEMBLY.**

**CAUTION:** Label all wires prior to disconnection when servicing controls. Wiring errors can cause improper and dangerous operation. Verify proper operation after servicing. This appliance and its venting system should be inspected before use and at least annually by a qualified service person. The appliance area must be kept clear and free of combustible materials, gasoline or other flammable vapors and liquids. The flow of combustion and ventilation air must not be obstructed.

- A.** In order to properly clean the burner and pilot assembly, remove the logs, rocks and/or glass to expose both assemblies.
- B.** Keep the control compartment, media, burner, air shutter opening and the area surrounding the logs clean by vacuuming or brushing, at least once a year.
- C.** Check to see that all burner ports are burning. Clean out any of the ports which may not be burning or are not burning properly.
- D.** Check to see that the pilot flame is large enough to engulf the flame sensor and/or thermocouple / thermopile as well as reaches the burner.
- E.** Replace the cleaned logs, rocks or glass. Failure to properly position the media may cause carboning which can be distributed in the surrounding living area.
- F.** Check to see that the main burner ignites completely on all openings when turned on. A 5 to 10 second total light-up period is satisfactory. If ignition takes longer, consult your local authorized dealer / distributor.
- G.** Check that the gasketing on the sides, top and bottom of the door is not broken or missing. Replace if necessary.
- H.** If for any reason the vent air intake system is disassembled, re-install and re-seal per the instructions provided for the initial installation.
- I.** Cleaning the safety barrier may be necessary due to excessive lint / dust from carpeting, pets, etc. simply vacuum using the brush attachment.
- J.** Ensure the relief system performs effectively. Check that the gasket is not worn or damaged. Replace if necessary.

40.1D



## 10.1 ANNUAL MAINTENANCE

**WARNING**

**THE FIREBOX BECOMES VERY HOT DURING OPERATION. LET THE APPLIANCE COOL COMPLETELY OR WEAR HEAT RESISTANT GLOVES BEFORE CONDUCTING SERVICE.**

**NEVER VACUUM HOT EMBERS.**

**DO NOT PAINT THE PILOT ASSEMBLY.**

- This appliance will require maintenance which should be planned on an annual basis.
- Service should include cleaning, battery replacement, venting inspection and inspection of the burner, media and firebox. Refer to the door removal section and remove the door as instructed.
- Carefully remove media if necessary (logs, glass, brick panels etc).
- Using a vacuum with a soft brush attachment, gently remove any dirt, debris or carbon build up from the logs, firebox and burner. For glass media, follow the installation instructions for pre-cleaning.
- Also gently remove any build-up on the pilot assembly including, if equipped; thermopile, thermocouple, flame sensor and igniter. **NOTE: The flame sensor may require to be cleaned using a fine steel wool or Scotch-Brite™ scrubbing pad to remove any oxides. Clean the pilot assembly using a vacuum with a soft brush attachment. It is important that the pilot assembly is not painted.**
- Inspect all accessible gaskets and replace as required.
- Access the blower, if equipped and clean using a soft brush and vacuum.
- Re-assemble the various components in reverse order.
- Inspect the relief system. The appliance relieves through the main glass door or through the flaps on the firebox top. Ensure they open freely, and close sealed.
- Check the gas control valve pilot and Hi / Lo knobs move freely (if equipped) – replace if any stiffness in movement is experienced.
- Check for gas leaks on all gas connections up and downstream from the gas valve including the pilot tube connections.

---

 37.1C

## 10.2 CONTROL ACCESS

Once the appliance has been framed and finished, control access can only be achieved by removing the access panel from the inside right side of the firebox. The following sub sections take you through the steps of accessing the control as if the appliance is installed.

\*Prior to removing the control panel follow the "DOOR REMOVAL" process and then follow the media removal instructions located under the "MAINTENANCE" section.

**NOTE: IT WILL BE NECESSARY TO REPLACE THE GASKET (W290-0238) FOR THE ACCESS PLATE IF THE UNIT HAS BEEN PREVIOUSLY OPERATED BEFORE REMOVING THE PLATE (W290-0238).**

- A. Remove the media from the appliance, follow removal instructions under the "MEDIA REMOVAL" section.
- B. Remove the right side brick / porcelain panel, follow removal instructions under the "BRICK / PORCELAIN PANEL REMOVAL" section.
- C. To remove the glass media trays to remove the glass burner, follow removal instructions under the "MEDIA TRAY" section (glass burner only).
- D. Remove the grate before removing the brick / porcelain panels, follow removal instructions under the "GRATE REMOVAL" section (log burner only).
- E. To access the controls remove the 8 screws securing the access plate from inside the firebox.
- F. Care should be taken to ensure avoiding damage to the gasket.
- G. Reverse this process to install the control access. Ensure the access plate is well sealed to the appliance.

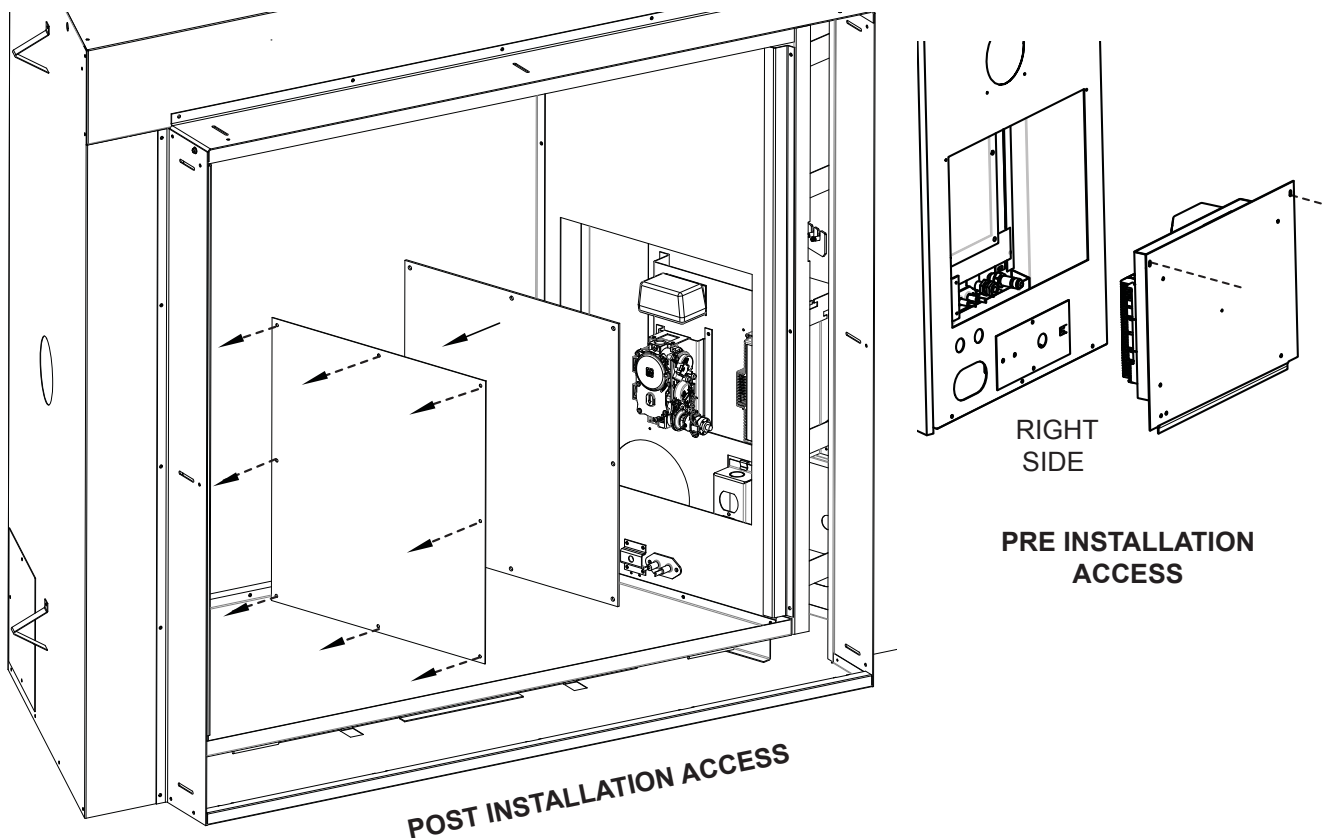



### 10.3 BURNER REMOVAL

- A. Remove any media and/or media tray from the appliance, refer to “MEDIA TRAY REMOVAL” section.
- B. Remove the screws from the burner assembly base and carefully lift from the firebox.



### 10.4 BRICK PANEL REMOVAL

- A. Remove the 2 screws securing the brick panel brackets from the top left of the appliance. Remove the screws securing the front brick retainers.
- B. Remove the left panel. **NOTE: Care must be taken with the rear panel as it rests against the left and right panels.**
- C. Repeat step (A) for the right side.
- D. Remove the rear panel by lifting it up and out of the rear panel support.



### 10.5 PORCELAIN PANEL REMOVAL

- A. Remove the 4 securing screws from the top / bottom left of the panel inside the firebox, remove the panel.
- B. Repeat on the right side.
- C. Remove the 4 securing screws from the top and bottom of the rear panel and remove.

### 10.6 MEDIA TRAY REMOVAL (GLASS ONLY)

- A. Vacuum the media from the appliance.
- B. Remove the 4 securing screws from the burner media tray and lift up and out, refer to Figure 1.
- C. Carefully lift the bottom media tray from the appliance, refer to Figure 2.

Fig. 1

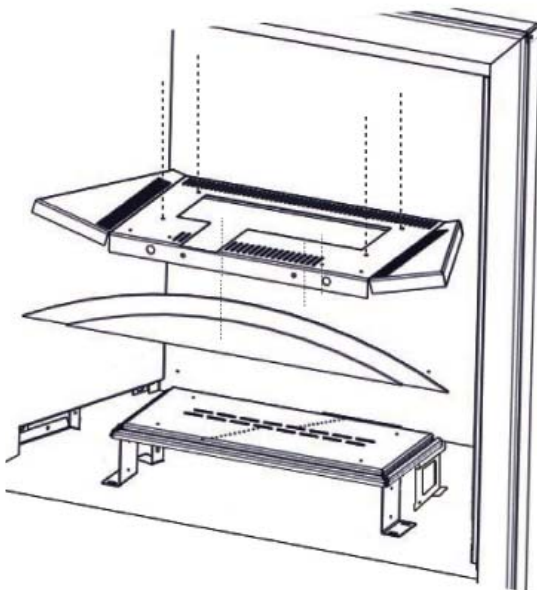
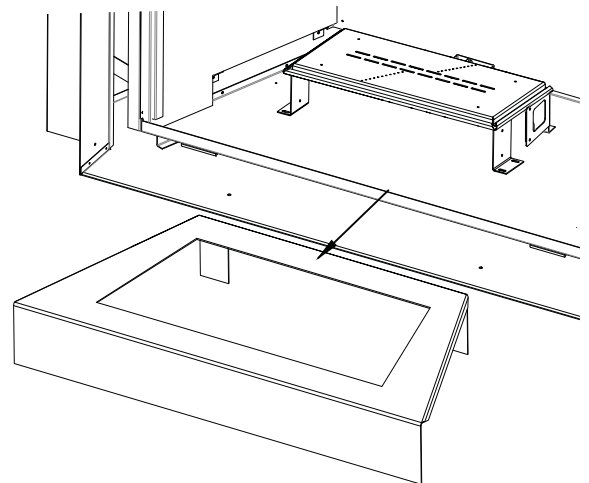

Fig. 2



## 10.7 NIGHT LIGHT™ REPLACEMENT

Your HDX35 comes equipped with a “Night Lights™”. The light has been pre-wired and is controlled from the remote control.

If in the event the lamps or lens need replacing, follow the instructions below:

- A. Shut off breaker at main power supply
- B. Remove the four screws that secure the lens frame to the firebox top. This frame retains the glass lens.
- C. The lamp can now be accessed.

**NOTE:** Do not handle the lamp (bulb) with bare fingers, protect with a clean dry cloth.

The lamp will pull straight out of the socket. Replace with Wolf Steel parts only, as lamp and lens are special “high temperature” products. When re-installing, ensure integrity of gasket seal.

### THE FIREBOX MUST BE SEALED.

Over tightening the screws could break the lens. “Light Leakage” from the holes in the housing lamp may be observed. The holes in the lamp housing are necessary for ventilation and must not be covered.

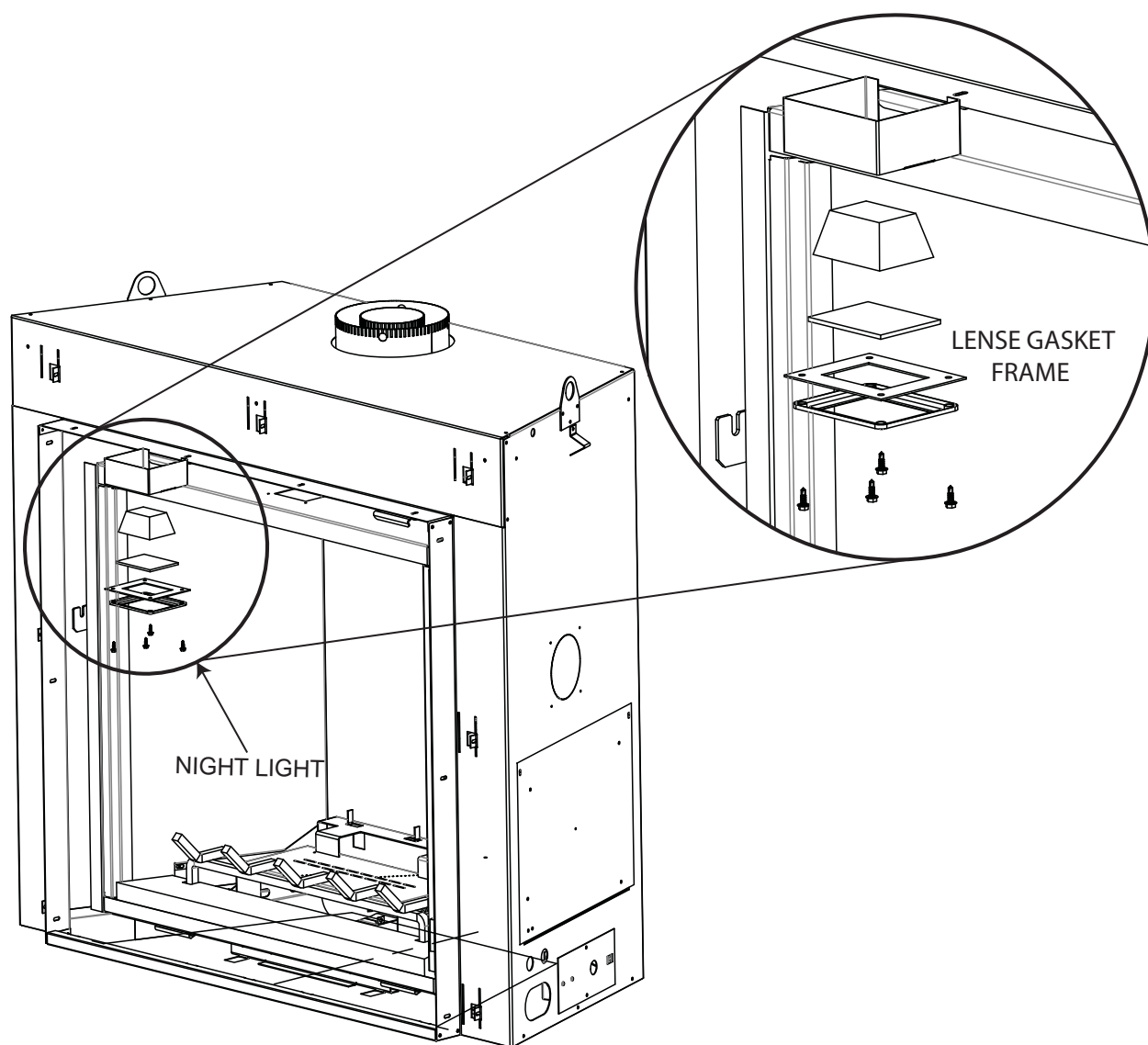

## 10.8 GLASS / DOOR REPLACEMENT

<b>! WARNING</b>
<b>DO NOT USE SUBSTITUTE MATERIALS.</b>
<b>GLASS MAY BE HOT, DO NOT TOUCH GLASS UNTIL COOLED.</b>
<b>CARE MUST BE TAKEN WHEN REMOVING AND DISPOSING OF ANY BROKEN DOOR GLASS OR DAMAGED COMPONENTS. BE SURE TO VACUUM UP ANY BROKEN GLASS FROM INSIDE THE APPLIANCE BEFORE OPERATION.</b>
<b>DO NOT STRIKE, SLAM OR SCRATCH GLASS. DO NOT OPERATE APPLIANCE WITH GLASS REMOVED, CRACKED, BROKEN OR SCRATCHED.</b>

56.2

- A. Place the door frame face down careful not to scratch the paint.
- B. Ensure the glass retainers are bent up prior to replacing the glass and gasket.
- C. Center the gasketed glass inside the door frame with the thick side of the gasket facing up.
- D. Bend the glass retainers located along the edge of the door frame over the gasket holding the glass in place. Be careful not to break the glass.

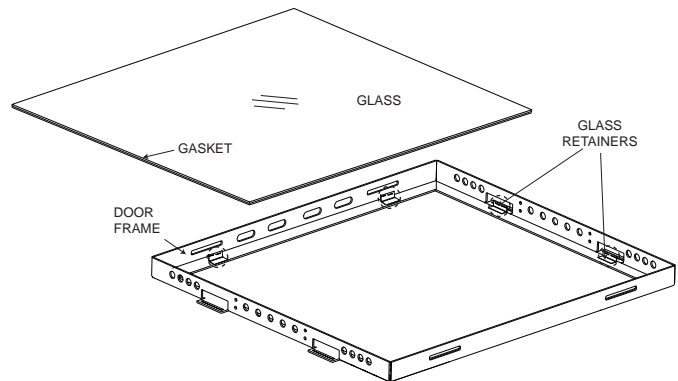

## 10.9 CARE OF GLASS

**DO NOT CLEAN GLASS WHEN HOT! DO NOT USE ABRASIVE CLEANERS TO CLEAN GLASS.**

Buff lightly with a clean dry soft cloth. Clean both sides of the glass after the first 10 hours of operation with a recommended fireplace glass cleaner. Thereafter clean as required. If the glass is not kept clean permanent discoloration and / or blemishes may result.

<b>! WARNING</b>	
	<p><b>HOT GLASS WILL CAUSE BURNS.</b></p> <p><b>DO NOT TOUCH GLASS UNTIL COOLED.</b></p> <p><b>NEVER ALLOW CHILDREN TO TOUCH GLASS.</b></p>

5.1

This appliance is factory equipped with 5mm ceramic glass. Use only replacement glass available from your Napoleon dealer. **DO NOT SUBSTITUTE MATERIALS.**

5.5.1

## 10.10 CARE OF PLATED PARTS

If the appliance is equipped with plated parts, you must clean fingerprints or other marks from the plated surfaces before operating the appliance for the first time. Use a glass cleaner or vinegar and towel to clean. If not cleaned properly before operating for the first time, the marks can cause permanent blemishes on the plating. After the plating is cured, the fingerprints and oils will not affect the finish and little maintenance is required, just wipe clean as needed. Prolonged high temperature burning with the door ajar may cause discoloration on plated parts.

**NOTE:** The protective wrap on plated parts is best removed when the assembly is at room temperature but this can be improved if the assembly is warmed, using a hair dryer or similar heat source.

6.1



## 11.0 REPLACEMENTS

Contact your dealer or the factory for questions concerning prices and policies on replacement parts. Normally all parts can be ordered through your Authorized dealer / distributor.

**FOR WARRANTY REPLACEMENT PARTS, A PHOTOCOPY OF THE ORIGINAL INVOICE WILL BE REQUIRED TO HONOUR THE CLAIM.**

When ordering replacement parts always give the following information:

- Model & Serial Number of appliance
- Installation date of appliance
- Part number
- Description of part
- Finish

**\* IDENTIFIES ITEMS WHICH ARE NOT ILLUSTRATED. FOR FURTHER INFORMATION, CONTACT YOUR AUTHORIZED DEALER.**

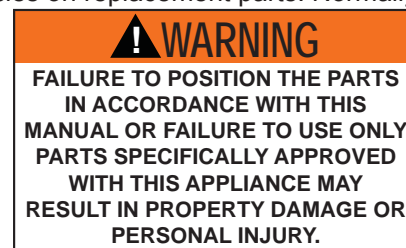

EN

41.1

# 12.0 OVERVIEW

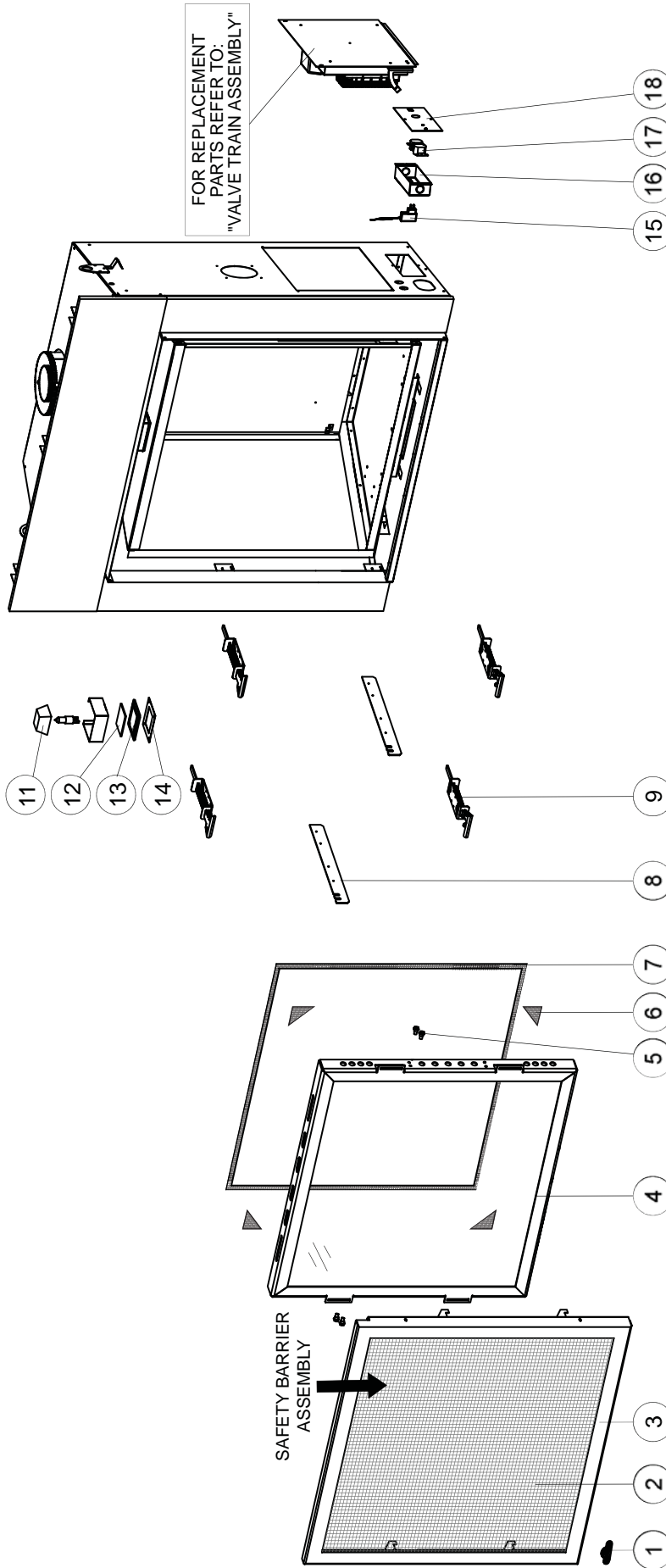

ITEMS MAY NOT APPEAR EXACTLY AS ILLUSTRATED

REF. NO.	PART NUMBER	DESCRIPTION	STOCKED
1	W385-2010	NAPOLEON LOGO	YES
2	W565-0194	SAFETY SCREEN	YES
3	W010-3528	SAFETY BARRIER ASSEMBLY	
4	W010-3465	DOOR ASSEMBLY	
5	W065-0034	SHOULDER BOLTS (X4)	YES
6	W667-0018	GASKET TAPE (X4)	YES
7	W562-0062	DOOR GASKET	YES
8	W080-1362	DOOR SECURING BRACKET (X2)	
9	W010-3518	DOOR LATCH ASSEMBLY (X4)	

REF. NO.	PART NUMBER	DESCRIPTION	STOCKED
10	N402-0001	LIGHT BULB	YES
11	W300-0067	NIGHT LIGHT GLASS	YES
12	W290-0080	NIGHT LIGHT GASKET	YES
13	W280-0071	LENSE FRAME	
14	W707-0006	TRANSFORMER	YES
15	W350-0464	ELECTRICAL BOX	
16	W460-0006	RECEPTACLE	
17	W500-0443	JUNCTION BOX COVER PLATE	

# 13.0 VALVE TRAIN ASSEMBLY

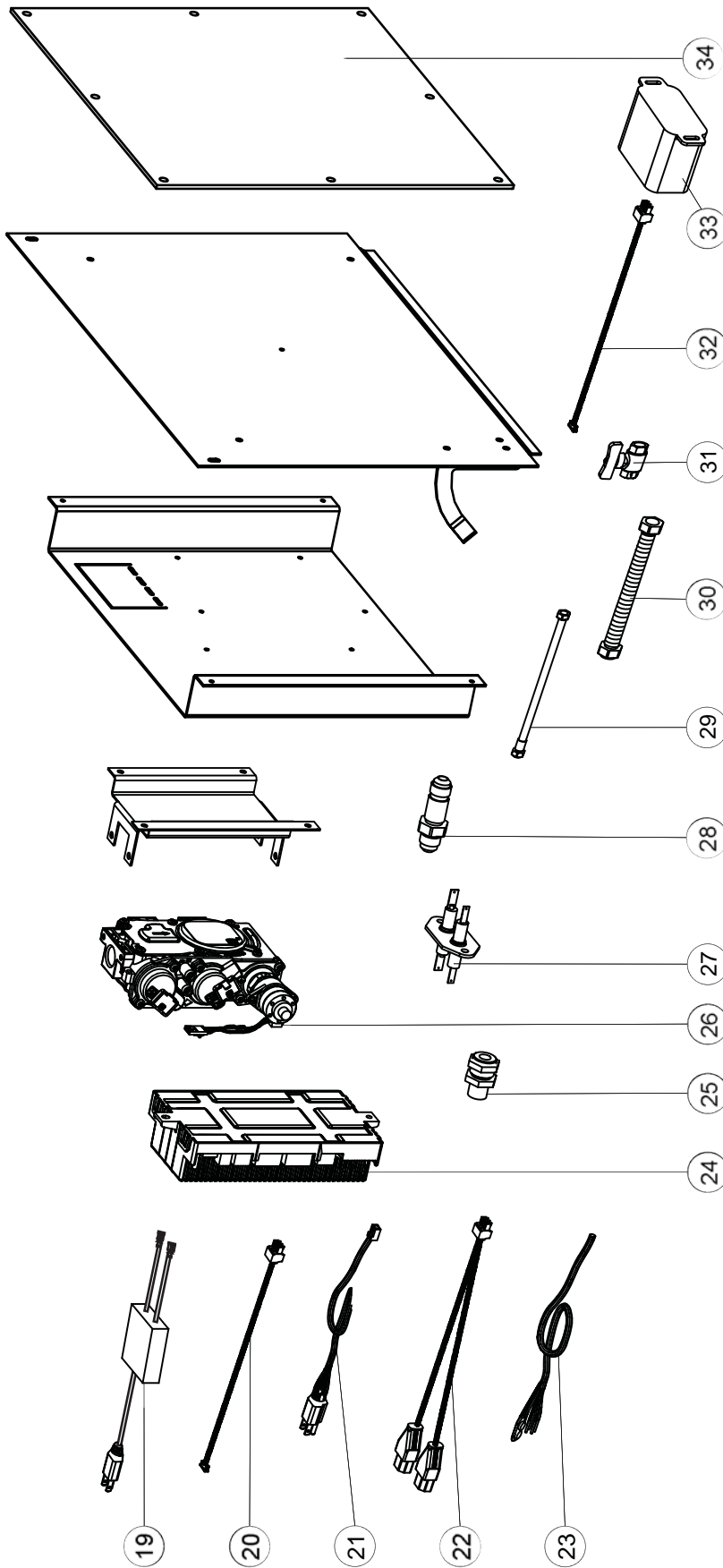

ITEMS MAY NOT APPEAR EXACTLY AS ILLUSTRATED

REF. NO.	PART NUMBER	DESCRIPTION	STOCKED	REF. NO.	PART NUMBER	DESCRIPTION	STOCKED
19	W707-0006	TRANSFORMER	YES	27	W240-0010	DOUBLE BULKHEAD ELECTRODE	YES
20	W750-0317	WIRE HARNESS EXTENSION		28	N255-0002	BULKHEAD FITTING	YES
21	W750-0294	POWER CORD		29	W720-0062	PILOT TUBE ASSEMBLY	YES
22	W750-0358	FEMALE PIG TAILS WITH CONNECTOR		30	W175-0311	FLEX CONNECTOR	
23	W750-0276	IPI/CPI JUMPER WIRE		31	W725-0046	SHUT-OFF VALVE	
24	W190-0073	CONTROL BOARD	YES	32	W750-0268	WIRE HARNESS	YES
25	W255-0021	PILOT TUBE BULKHEAD FITTING	YES	33	W350-0655	RECEIVER	YES
26	W725-0056	VALVE (NG)	YES	34	W290-0280	CONTROL PANEL ACCESS GASKET	YES
26	W725-0057	VALVE (LP)	YES				

# 14.0 LOG BURNER

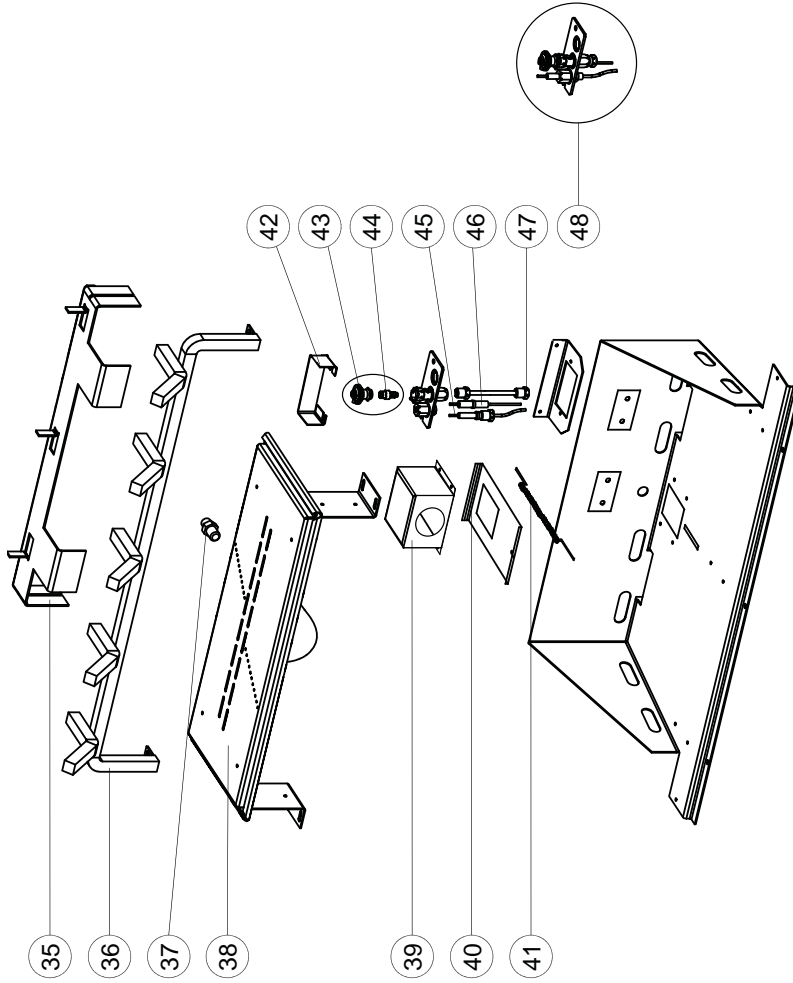

ITEMS MAY NOT APPEAR EXACTLY AS ILLUSTRATED

REF. NO.	PART NUMBER	DESCRIPTION	STOCKED	REF. NO.	PART NUMBER	DESCRIPTION	STOCKED
35	W655-0560	LOG SUPPORT		43	W335-0039	PILOT HOOD	YES
36	W010-3469	GRATE ASSEMBLY		44	W455-0070	PILOT ORIFICE #62 (NG)	YES
37	W456-0031	BURNER ORIFICE #31 (NG)	YES	44	W455-0068	PILOT ORIFICE #35 (LP)	YES
37	W456-0049	BURNER ORIFICE #49 (LP)	YES	45	W245-0025	THERMOSENSOR	YES
38	W100-0183	BURNER ASSEMBLY		46	W240-0006	IGNITOR (w/ WIRE)	YES
39	W350-0768	AIR SHUTTER HOUSING		47	W720-0062	PILOT TUBE (w/ FITTINGS)	YES
40	W500-0816	AIR SHUTTER PLATE		48	W010-2863	PILOT ASSEMBLY (NG)	
41	W010-3646	AIR CONTROL CABLE		48	W010-2808	PILOT ASSEMBLY (LP)	
42	W350-0725	PILOT HOUSING					

# 15.0 GLASS BURNER

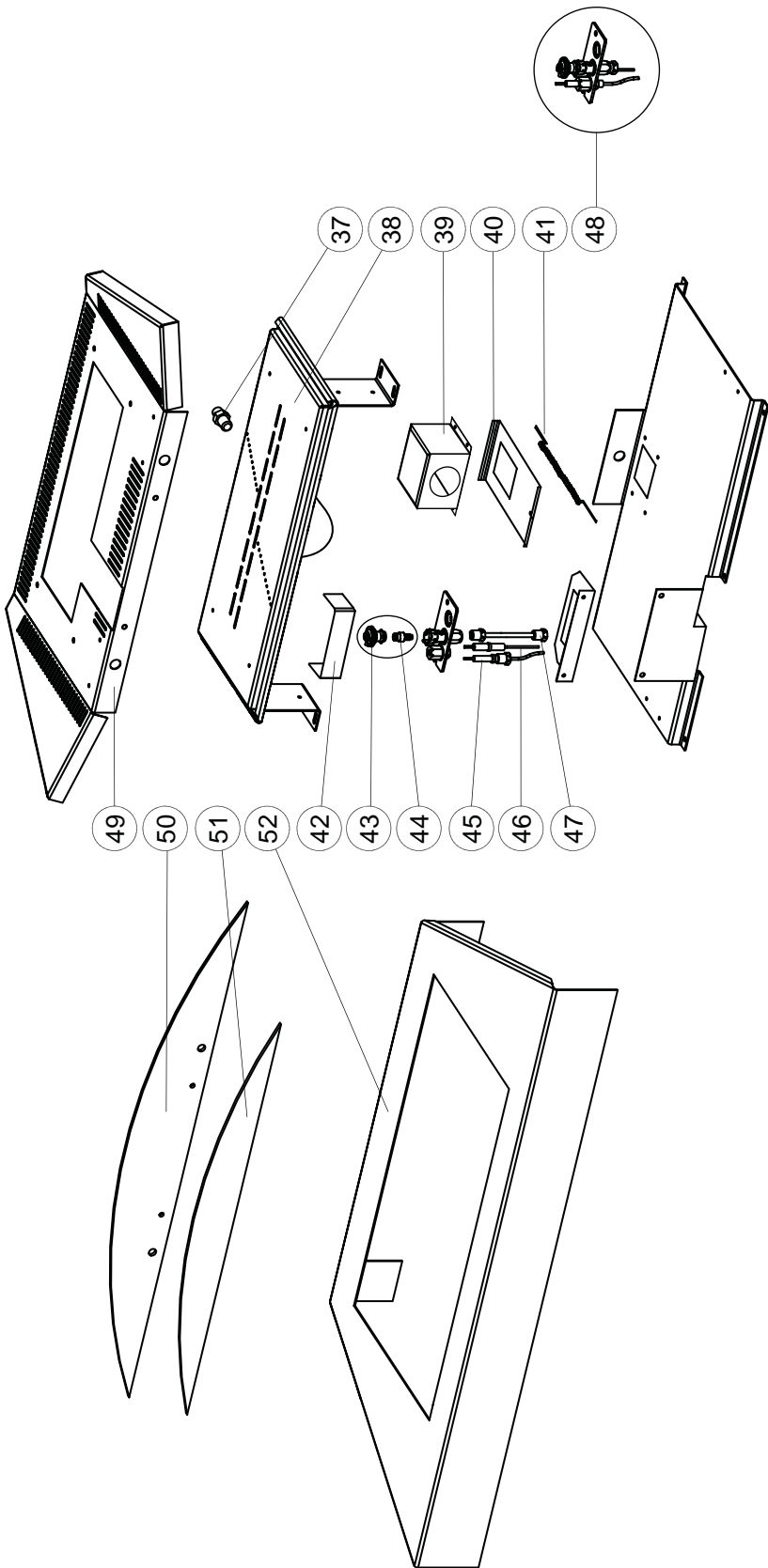

ITEMS MAY NOT APPEAR EXACTLY AS ILLUSTRATED

REF. NO.	PART NUMBER	DESCRIPTION	STOCKED
37	W456-0031	BURNER ORIFICE #31 (NG)	YES
37	W456-0049	BURNER ORIFICE #49 (LP)	YES
38	W100-0183	BURNER ASSEMBLY	
39	W350-0768	AIR SHUTTER HOUSING	
40	W500-0816	AIR SHUTTER PLATE	
41	W010-3646	AIR CONTROL CABLE	
42	W350-0725	PILOT HOUSING	
43	W335-0062	PILOT HOOD	YES
44	W455-0070	PILOT ORIFICE #62 (NG)	YES
44	W455-0068	PILOT ORIFICE #35 (LP)	YES

REF. NO.	PART NUMBER	DESCRIPTION	STOCKED
45	W245-0025	THERMOSENSOR	YES
46	W240-0006	IGNITOR (w/ WIRE)	YES
47	W720-0062	PILOT TUBE (w/ FITTINGS)	YES
48	W010-2863	PILOT ASSEMBLY (NG)	
48	W010-2808	PILOT ASSEMBLY (LP)	
49	W710-0075	GLASS MEDIA TRAY	
50	W655-0449	MEDIA SUPPORT	
51	W010-2997	MEDIA TRIM ASSEMBLY	
52	W710-0073	GLASS MEDIA BOWL TRAY	

# 16.0 ACCESSORIES

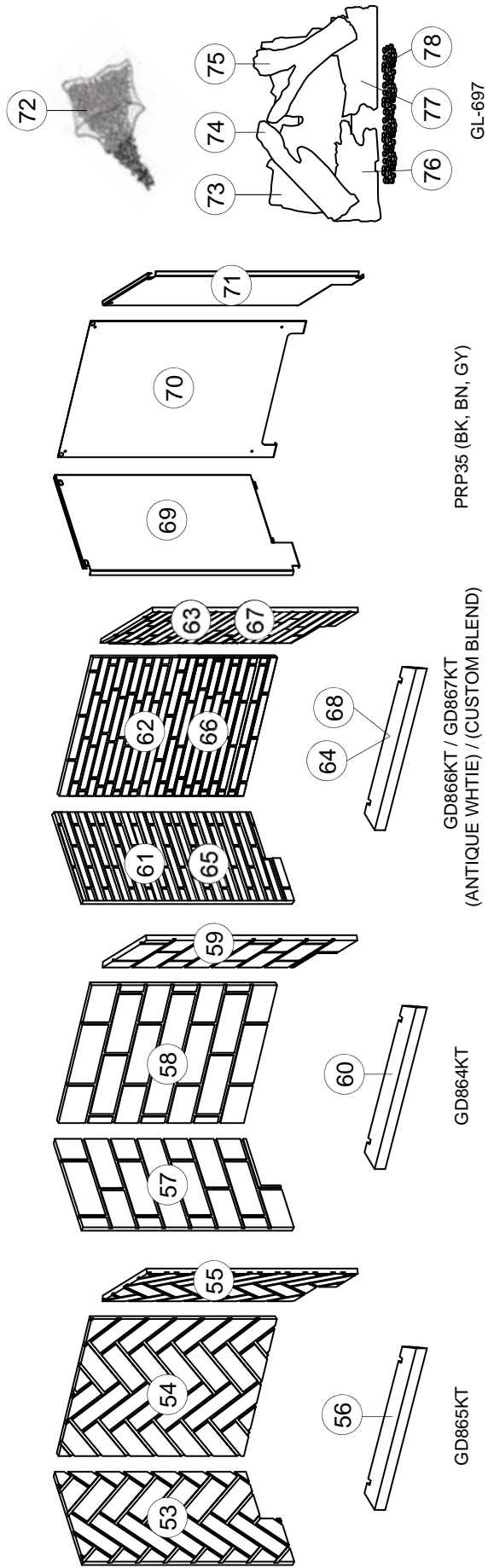

ITEMS MAY NOT APPEAR EXACTLY AS ILLUSTRATED

REF. NO.	PART NUMBER	DESCRIPTION	STOCKED	REF. NO.	PART NUMBER	DESCRIPTION	STOCKED
53	W090-0291	(LS) HERRINGBONE BRICK PANEL (GD865KT)		68	W090-0298	LEDGESTONE HEARTH PAD (GD867KT)	
54	W090-0289	REAR HERRINGBONE BRICK PANEL (GD865KT)		69	W090-0278	(LS) PORCELAIN PANEL (PRP35)	
55	W090-0290	(RS) HERRINGBONE BRICK PANEL (GD865KT)		70	W090-0276	REAR PORCELAIN PANEL (PRP35)	
56	W090-0292	HERRINGBONE HEARTH PAD (GD865KT)		71	W090-0277	(RS) PORCELAIN PANEL (PRP35)	
57	W090-0295	(LS) NEWPORT PANEL REAR (GD864KT)		72	MEGK	BLACK GLASS EMBERS (1lb)	
58	W090-0297	NEWPORT PANEL REAR (GD864KT)		72	MEGB	BLUE GLASS EMBERS (1lb)	
59	W090-0296	(RS) NEWPORT PANEL (GD864KT)		72	MEGR	RED GLASS EMBERS (1lb)	
60	W090-0294	NEWPORT PANEL HEARTH PAD (GD864KT)		72	MEGA	AMBER GLASS EMBERS (1lb)	
61	W090-0301	(LS) LEDGESTONE BRICK PANEL (GD866KT)		72	MEGT	TOPAZ GLASS EMBERS (1lb)	
62	W090-0300	REAR LEDGESTONE BRICK PANEL (GD866KT)		73	W135-0594	TOP REAR LOG (GL-697)	
63	W090-0302	(RS) LEDGESTONE BRICK PANEL (GD866KT)		74	W135-0593	LEFT CROSSOVER LOG (GL-697)	
64	W090-0299	LEDGESTONE HEARTH PAD (GD866KT)		75	W135-0595	RIGHT CROSSOVER LOG (GL-697)	
65	W090-0304	(LS) LEDGESTONE BRICK PANEL (GD867KT)		76	W135-0597	LEFT LOG (GL-697)	
66	W090-0293	REAR LEDGESTONE BRICK PANEL (GD867KT)		77	W135-0598	RIGHT LOG (GL-697)	
67	W090-0303	(RS) LEDGESTONE BRICK PANEL (GD867KT)		78	W361-0016	GLOWING EMBERS (GL-697)	YES
				79	RP4-KT	RESTRICTOR PLATE	YES

## 17.0 TROUBLESHOOTING

**! WARNING**

**ALWAYS LIGHT THE PILOT WHETHER FOR THE FIRST TIME OR IF THE GAS SUPPLY HAS RUN OUT, WITH THE GLASS DOOR OPEN OR REMOVED.**

**TURN OFF THE GAS AND ELECTRICAL POWER BEFORE SERVICING THE APPLIANCE.**

**APPLIANCE MAY BE HOT, DO NOT SERVICE UNTIL APPLIANCE HAS COOLED.**

**DO NOT USE ABRASIVE CLEANERS.**

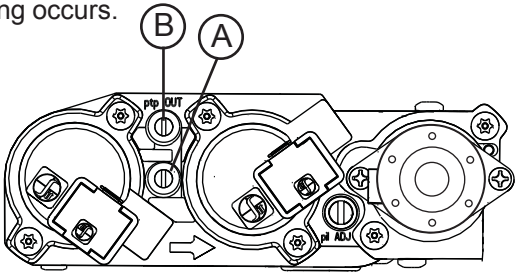
SYMPTOM	PROBLEM	TEST SOLUTION															
Remote controls Crystalite / Night light but no spark or flame.	Remote is locked out.	- Reset by turning power source off then on. <b>NOTE: If back up batteries are installed, they must also be removed to re-program.</b>															
Main burner flame is a blue, lazy, transparent flame.	Blockage in vent.	- Remove blockage. In really cold conditions, ice buildup may occur on the terminal and should be removed as required. To minimize this from happening again, it is recommended that the vent lengths that pass through unheated spaces (attics, garages, crawl spaces) be wrapped with an insulated mylar sleeve. Prevent sleeve from sagging. Contact your local authorized dealer for more information.															
	Incorrect installation.	- Refer to "VENTING" section to ensure correct installation.															
Flames are consistently too large or too small. Carboning occurs.	Appliance is over-fired or underfired.	- <b>Check pressure readings:</b> <i>Inlet pressure</i> can be checked by turning screw (A) counter-clockwise 2 or 3 turns and then placing pressure gauge tubing over the test point. Gauge should read as described on the chart below. Check that main burner is operating on 'HI'. <i>Outlet pressure</i> can be checked the same as above using screw (B). Gauge should read as described on the chart below. Check that main burner is operating on 'HI'. <b>AFTER TAKING PRESSURE READINGS, BE SURE TO TURN SCREWS CLOCKWISE FIRMLY TO RESEAL. DO NOT OVER TORQUE.</b> Leak test with a soap and water solution.															
																	
		<table border="1"> <thead> <tr> <th>Pressure</th> <th>Natural Gas (inches)</th> <th>Natural Gas (millibars)</th> <th>Propane (inches)</th> <th>Propane (millibars)</th> </tr> </thead> <tbody> <tr> <td>Inlet</td> <td>7" (MIN. 4.5")</td> <td>17.4mb (MIN. 11.2mb)</td> <td>13" (MIN. 11")</td> <td>32.4mb (MIN. 27.4mb)</td> </tr> <tr> <td>Outlet</td> <td>3.5"</td> <td>8.7mb</td> <td>10"</td> <td>24.9mb</td> </tr> </tbody> </table>	Pressure	Natural Gas (inches)	Natural Gas (millibars)	Propane (inches)	Propane (millibars)	Inlet	7" (MIN. 4.5")	17.4mb (MIN. 11.2mb)	13" (MIN. 11")	32.4mb (MIN. 27.4mb)	Outlet	3.5"	8.7mb	10"	24.9mb
Pressure	Natural Gas (inches)	Natural Gas (millibars)	Propane (inches)	Propane (millibars)													
Inlet	7" (MIN. 4.5")	17.4mb (MIN. 11.2mb)	13" (MIN. 11")	32.4mb (MIN. 27.4mb)													
Outlet	3.5"	8.7mb	10"	24.9mb													
Carbon is being deposited on glass, logs, rocks, media or combustion chamber surfaces.	Air shutter has become blocked.  Flame is impinging on the glass, logs, rocks, media or combustion chamber.	- Ensure air shutter opening is free of lint or other obstructions.  - Check that the glass, logs, rocks, media are correctly positioned. - Open air shutter to increase the primary air. - Check the input rate: check the manifold pressure and orifice size as specified by the rating plate. - Check that the door gasketing is not broken or missing and that the seal is tight. - Check that both vent liners are free of holes and well sealed at all joints. - Check that minimum rise per foot (meters) has been adhered to for any horizontal venting.															



SYMPTOM	PROBLEM	TEST SOLUTION
White / grey film forms.	Sulphur from fuel is being deposited on glass, logs or combustion chamber surfaces.	<ul style="list-style-type: none"> <li>- Clean the glass with a recommended gas fireplace glass cleaner. DO NOT CLEAN GLASS WHEN HOT.</li> <li>- If deposits are not cleaned off regularly, the glass may become permanently marked.</li> </ul>
Exhaust fumes smelled in room, headaches.	Appliance is spilling.	<ul style="list-style-type: none"> <li>- Check door seal.</li> <li>- Check for exhaust damage.</li> <li>- Check that venting is installed correctly.</li> <li>- Room is in negative pressure; increase fresh air supply.</li> </ul>
Pilot will not light. Makes noise with no spark at pilot burner.	Wiring.	<ul style="list-style-type: none"> <li>- Verify the wire for the sensor and the wire for the ignitor are connected to the correct terminals (not reverse) on the module and pilot assembly.</li> </ul>
	Loose connection.	<ul style="list-style-type: none"> <li>- Verify no loose connections, electrical shorts in the wiring or ground out to any metal object.</li> </ul>
	Igniter Spark gap is incorrect.	<ul style="list-style-type: none"> <li>- Spark gap of the ignitor to the pilot should be .125" (3.2mm).</li> </ul>
Pilot will not light. Makes no noise with no spark at pilot burner. Crystalites™ and (optional) blower operates.	A shorted or loose connection.	<ul style="list-style-type: none"> <li>- Remove and reinstall the wiring harness that plugs into the module.</li> <li>- Remove and verify continuity of each wire in the wiring harness.</li> </ul>
	Module is not grounded.	<ul style="list-style-type: none"> <li>- Verify the valve and pilot assemblies are properly grounded to the metal chassis of the fireplace.</li> </ul>
	Ignition box has been locked out.	<p>Choose one of the 4 methods below to reset the system.</p> <ol style="list-style-type: none"> <li>1. To reset ignition box when locked out. Turn off power supply and remove batteries (if used) from the back up battery pack.</li> <li>2. To reset the DFC Board when the board goes into a lock out condition and the LED is blinking 3 times using the transmitter ON/OFF button: <ul style="list-style-type: none"> <li><b>Step 1:</b> Turn the system off by pressing the ON/OFF button to turn the system off.</li> <li><b>Step 2:</b> After approximately 2 seconds press the ON/OFF button on the transmitter again. THE DFC Board will reset and the ignition sequence will start again.</li> </ul> </li> <li>3. To reset the DFC Board when the board goes into a lock out condition and the LED is blinking 3 times by cycling flame: <ul style="list-style-type: none"> <li><b>Step 1:</b> In the manual flame control mode, use the down arrow button to reduce the flame to off, indicated by the word OFF displayed on the trasmitter LCD screen.</li> <li><b>Step 2:</b> Wait approximately 2 seconds and press the up arrow button, the ignition sequence will start.</li> </ul> </li> </ol>
<p><b>NOTE: Starting from OFF, press the ON button on the transmitter. Approximately 4 seconds after the ON/OFF button is pressed the ignition board will start the spark. The first try for ignition will last approximately 60 seconds. If there is no flame ignition (rectification) the board will stop sparking for approximately 35 seconds. After the wait time the board will start the second try for ignition by sparking for approximately 60 seconds. If there is still no positive ignition, the board will go into lock out.</b></p>		



SYMPTOM	PROBLEM	TEST SOLUTION
Pilot sparks but will not light.	Gas supply.	<ul style="list-style-type: none"> <li>- Verify that the incoming gas line ball valve is “Open”.</li> <li>- Verify that the inlet pressure reading is within acceptable limits, inlet pressures must not exceed 14” W.C. (34.9mb).</li> </ul>
	Module is not grounded.	<ul style="list-style-type: none"> <li>- Verify the value and pilot assemblies are properly grounded to the metal chassis of the fireplace.</li> </ul>
	Out of propane gas.	<ul style="list-style-type: none"> <li>- Fill the tank.</li> </ul>
Continues to spark and pilot lights, but main burner will not light.	Short or loose connection in sensor rod.	Verify all connections. Verify the connections from the pilot assembly are tight; also verify these connections are not grounding out to any metal.
	Poor flame rectification or contaminated sensor rod.	<ul style="list-style-type: none"> <li>- Verify the flame is engulfing the sensor rod. This will increase the flame rectification. Verify correct pilot orifice is installed and inlet gas specifications to manual. (Remember, the flame carries the rectification current, not the gas. If the flame lifts from pilot hood, the circuit is broken. A wrong orifice or too high of an inlet pressure can cause the pilot flame to lift.) The sensor rod may need cleaning.</li> </ul>
	Poor grounding between pilot assembly and gas valve.	<ul style="list-style-type: none"> <li>- Verify that the wire harness is firmly connected to module.</li> </ul>
	Damaged pilot or dirty sensor rod.	<ul style="list-style-type: none"> <li>- Verify that the ceramic insulator around the sensor rod is not cracked, damaged, or loose. Verify the connection from the sensor rod to the sensor wire. Clean sensor rod with a green Scotch-Brite pad to remove any contamination that may have accumulated on the sensor rod. Verify continuity with multimeter with ohms set at the lowest range.</li> </ul>
	Pilot has been painted	<ul style="list-style-type: none"> <li>- Using a scrub pad, remove the paint from the pilot hood, ignitor and flame sensor.</li> </ul>
Appliance won't perform any functions.	Receiver switch is in the wrong position.	<ul style="list-style-type: none"> <li>- Verify that the 3 position switch on the receiver is in the “REMOTE” position (middle).</li> </ul>
	No power to the system.	<ul style="list-style-type: none"> <li>- Check breaker to verify it's in the “ON” position.</li> </ul>
	Transmitter isn't operational.	<ul style="list-style-type: none"> <li>- Check battery power and battery orientation.</li> </ul>
Night light or (optional) blower won't function	Control module switch is in the wrong position.	<ul style="list-style-type: none"> <li>- Verify ON/OFF switch is in the “I” position which denotes on.</li> </ul>
	COM switch is unplugged.	<ul style="list-style-type: none"> <li>- Verify “COM” switch is plugged into the front of the control module.</li> </ul>

## 18.0 WARRANTY

NAPOLEON products are manufactured under the strict Standard of the world recognized ISO 9001 : 2008 Quality Assurance Certificate.

NAPOLEON products are designed with superior components and materials assembled by trained craftsmen who take great pride in their work. The burner and valve assembly are leak and test-fired at a quality test station. The complete appliance is again thoroughly inspected by a qualified technician before packaging to ensure that you, the customer, receives the quality product that you expect from NAPOLEON.

### NAPOLEON GAS APPLIANCE PRESIDENT'S LIFETIME LIMITED WARRANTY

The following materials and workmanship in your new NAPOLEON gas appliance are warranted against defects for as long as you own the appliance. This covers: combustion chamber, heat exchanger, stainless steel burner, phazer™ logs and embers, rocks, ceramic glass (thermal breakage only), gold plated parts against tarnishing, porcelainized enameled components and aluminum extrusion trims.\*

Electrical (110V and millivolt) components and wearable parts such as blowers, gas valves, thermal switch, switches, wiring, remote controls, ignitor, gasketing, and pilot assembly are covered and NAPOLEON will provide replacement parts free of charge during the first year of the limited warranty.\*

Labour related to warranty repair is covered free of charge during the first year. Repair work, however, requires the prior approval of an authorized company official. Labour costs to the account of NAPOLEON are based on a predetermined rate schedule and any repair work must be done through an authorized NAPOLEON dealer.

\* Construction of models vary. Warranty applies only to components included with your specific appliance.

### CONDITIONS AND LIMITATIONS

NAPOLEON warrants its products against manufacturing defects to the original purchaser only. Registering your warranty is not necessary. Simply provide your proof of purchase along with the model and serial number to make a warranty claim. NAPOLEON reserves the right to have its representative inspect any product or part thereof prior to honouring any warranty claim. Provided that the purchase was made through an authorized NAPOLEON dealer your appliance is subject to the following conditions and limitations:

Warranty coverage begins on the date of original installation.

This factory warranty is non-transferable and may not be extended whatsoever by any of our representatives.

The gas appliance must be installed by a licensed, authorized service technician or contractor. Installation must be done in accordance with the installation instructions included with the product and all local and national building and fire codes.

This limited warranty does not cover damages caused by misuse, lack of maintenance, accident, alterations, abuse or neglect and parts installed from other manufacturers will nullify this warranty.

This limited warranty further does not cover any scratches, dents, corrosion or discoloring caused by excessive heat, abrasive and chemical cleaners nor chipping on porcelain enamel parts, mechanical breakage of PHAZER™ logs and embers.

This warranty extends to the repair or replacement of warranted parts which are defective in material or workmanship provided that the product has been operated in accordance with the operation instructions and under normal conditions.

After the first year, with respect to this President's Lifetime Limited Warranty, NAPOLEON may, at its discretion, fully discharge all obligations with respect to this warranty by refunding to the original warranted purchaser the wholesale price of any warranted but defective part(s).

NAPOLEON will not be responsible for installation, labour or any other expenses related to the reinstallation of a warranted part and such expenses are not covered by this warranty.

Notwithstanding any provisions contained in the President's Lifetime Limited Warranty, NAPOLEON'S responsibility under this warranty is defined as above and it shall not in any event extend to any incidental, consequential or indirect damages.

This warranty defines the obligations and liability of NAPOLEON with respect to the NAPOLEON gas appliance and any other warranties expressed or implied with respect to this product, its components or accessories are excluded.

NAPOLEON neither assumes, nor authorizes any third party to assume, on its behalf, any other liabilities with respect to the sale of this product.

NAPOLEON will not be responsible for: over-firing, downdrafts, spillage caused by environmental conditions such as rooftops, buildings, nearby trees, hills, mountains, inadequate vents or ventilation, excessive venting configurations, insufficient makeup air, or negative air pressures which may or may not be caused by mechanical systems such as exhaust fans, furnaces, clothes dryers, etc.

Any damages to the appliance, combustion chamber, heat exchanger, plated trim or other components due to water, weather damage, long periods of dampness, condensation, damaging chemicals or cleaners will not be the responsibility of NAPOLEON.

All parts replaced under the President's Limited Lifetime Warranty Policy are subject to a single claim.

During the first 10 years NAPOLEON will replace or repair the defective parts covered by the lifetime warranty at our discretion free of charge. From 10 years to life, NAPOLEON will provide replacement parts at 50% of the current retail price.

All parts replaced under the warranty will be covered for a period of 90 days from the date of their installation.

The manufacturer may require that defective parts or products be returned or that digital pictures be provided to support the claim. Returned products are to be shipped prepaid to the manufacturer for investigation. If a product is found to be defective, the manufacturer will repair or replace such defect.

Before shipping your appliance or defective components, your dealer must obtain an authorization number. Any merchandise shipped without authorization will be refused and returned to sender.

Shipping costs are not covered under this warranty.

Additional service fees may apply if you are seeking warranty service from a dealer.

Warranty labour allowance is only for the replacement of the warranted part. Travel, diagnostic tests, shipping and other related charges are not covered by this warranty.

ALL SPECIFICATIONS AND DESIGNS ARE SUBJECT TO CHANGE WITHOUT PRIOR NOTICE DUE TO ON-GOING PRODUCT IMPROVEMENTS. NAPOLEON IS A REGISTERED TRADEMARK OF WOLF STEEL LTD.

AS REQUIRED BY THE DEPARTMENT OF ENERGY IN THE UNITED STATES, 10 CFR PART 430, THE WARRANTY IS VOID IF THIS PRODUCT IS USED WITH A THERMOSTAT. THIS APPLIES TO PRODUCT INSTALLED IN THE UNITED STATES, ONLY.



Other Napoleon Products



Fireplace Inserts • Charcoal Grills • Gas Fireplaces • Waterfalls • Wood Stoves  
Heating & Cooling • Electric Fireplaces • Outdoor Fireplaces • Gas Grills



24 Napoleon Road, Barrie, Ontario, Canada L4M 0G8  
214 Bayview Drive, Barrie, Ontario, Canada L4N 4Y8  
103 Miller Drive, Crittenden, Kentucky, USA 41030  
7200 Trans Canada Highway, Montreal, Quebec, Canada H4T 1A3

Fireplaces / Heating & Cooling call: 705-721-1212 • Grills call: 705-726-4278  
napoleonproducts.com