

Installation & Maintenance Manual



MONTIGO[®]
the art of **fireplaces**

Phenom INDOOR GAS FIREPLACE

P38, PL38 25,000 BTU/hr Natural Gas or Propane Gas

P42, PL42 32,000 BTU/hr Natural Gas or Propane Gas

P52, PL52 40,000 BTU/hr Natural Gas or Propane Gas



NOTICE

Installer: Leave this manual with the appliance.
Consumer: Retain this manual for future reference.

⚠ WARNING:
FIRE OR EXPLOSION HAZARD

Failure to follow safety warnings exactly could result in serious injury, death, or property damage.

- Do not store or use gasoline or other flammable vapors and liquids in the vicinity of this or any other appliance.
- **WHAT TO DO IF YOU SMELL GAS**
 - Do not try to light any appliance.
 - Do not touch any electrical switch; do not use any phone in your building.
 - Leave the building immediately.
 - Immediately call your gas supplier from a neighbour's phone. Follow the gas supplier's instructions.
 - If you cannot reach your gas supplier, call the fire department.
- Installation and service must be performed by a qualified installer, service agency or the gas fitter.

⚠ CAUTION

Installation and service must be performed by a qualified installer, service agency or the gas fitter.

⚠ DANGER

Read and understand this manual. Improper installation, adjustment, alteration, service or maintenance can cause serious injury, property damage or even death. For assistance or additional information consult a qualified installer, service agency or the gas supplier.

⚠ WARNING

Some materials used in the manufacturing process of this product can expose you to Benzene which is known in the State of California to cause cancer and birth defects or other reproductive harm. For more information go to www.P65warnings.ca.gov

⚠ DANGER



HOT GLASS WILL CAUSE BURNS.
DO NOT TOUCH GLASS UNTIL COOLED.
NEVER ALLOW CHILDREN TO TOUCH GLASS.

A barrier designed to reduce the risk of burns from the hot viewing glass is provided with this appliance and must be installed for the protection of children and other at-risk individuals.

Canada

ENERGUIDE

Look for the **EnerGuide**
Gas Fireplace Energy
Efficiency Rating in this brochure

Based on **CSA P.4.1-15**

Safety Alert Key

DANGER

Indicates a hazardous situation which, if not avoided, WILL result in death or serious injury or property damage.

WARNING

Indicates a hazardous situation which, if not avoided, COULD result in death or serious injury or property damage.

CAUTION

Indicates a hazardous situation which, if not avoided, WILL result in minor or moderate injury.

NOTICE

Indicates practices that are important, but not related to personal injury.

Introduction

Congratulations on your purchase of a Montigo Fireplace.

With over 30 years of experience, Montigo is committed to providing you with a gas fireplace that is not only a beautiful addition to your space, but that is also designed and manufactured to the highest safety, reliability and engineering standards.

We strongly encourage you to read and carefully follow the instructions laid out in this Installation, Operation and Maintenance Manual and retain it for your future reference. Pay special attention to all cautions, warnings, and notices throughout this manual intended to ensure your safety.

This manual covers installation, operation and maintenance. Lighting, operation and care of this fireplace can be easily performed by the homeowner. All installation and service work should be performed by a qualified or licensed installer, plumber or gas fitter as certified by the state, province, region or governing body where the fireplace is being installed.

This installation, operation and maintenance manual is applicable to the models described in Table 1. Refer to your rating plate to verify included options.

Warranty and Installation Information: (See Appendix B)

The Montigo warranty will be voided by, and Montigo disclaims any responsibility for, the following actions:

- Modification of the fireplace and/or components including Direct-Vent assembly or glass doors.
- Use of any component part not manufactured or approved by Montigo in combination with this Montigo fireplace system.
- Installation other than as instructed in this manual.
- Consult your local Gas Inspection Branch on installation requirements for factory-built gas fireplaces. Installation & repairs should be done by a qualified contractor.

MODEL	Natural Gas		Gas Rating (BTU hr)	Efficiency P.4.1-15
	Natural Gas	Liquid Propane		
P38DFN-F	X		25,000	58
P38DFL-F		X	25,000	58
PL38DFN-F	X		25,000	58
PL38DFL-F		X	25,000	58
P42DFN-F	X		32,000	57
P42DFL-F		X	32,000	60
PL42DFN-F	X		32,000	57
PL42DFL-F		X	32,000	60
P52DFN-F	X		40,000	56
P52DFL-F		X	40,000	59
PL52DFN-F	X		40,000	56
PL52DFL-F		X	40,000	59

Figure 1 Phenom Specifications

Contents

Safety Alert Key	2	Fuel Type.....	32
Introduction.....	2	Gas Pressure	32
Section A: Before You Begin	4	Section 5-3: GAS CONNECTION.....	32
Installation Checklist	4	Section 6: Finishing.....	33
Standard Installation Checklist	5	Finishing Around the Fireplace	33
Rating Plate Sample.....	6	Finishing the Fireplace	34
Section 1: Product Dimensions	7	Flush Finishing the Fireplace.....	34
P/PL 38 Dimensions	7	Section 7: Screen Installation and Removal.....	35
P/PL 42 Dimensions	7	Removing the Screen	35
P/PL 52 Dimensions	8	To Install Screens:.....	35
Section 2: Framing	9	Replacement Screens:.....	35
In Wall and Corner Dimensions	9	Section 8: Installing & Removing the Door	36
Alcove Dimensions	9	Removing the door:.....	36
Clearances:.....	11	Reinstalling the door	36
Installing The Standoffs	11	Section 9: Installing the Accessories.....	37
Installing the Nailing Flange Extension	11	Installing the Uplighting Glass.....	37
Section 3: Venting	12	Installing the Firestones or optional Fireglass	37
Section 3-2: Installing a Roof Mounted Direct Vent Termination for 5"/8" (PVTK1SS).....	13	Installing Optional Speckled Stones	37
Section 3-2-1: Venting Layout.....	13	Optional Log Set	38
5"/8" Piping for P52 and PL52 units	14	Log Kit Installation	38
Section 3-3: Installing a Wall Mounted Termination 5"/8".....	15	Remote Operation (Optional for PL Units)	41
Installing a Wall Mounted Termination 5"/10".....	16	Section 10: Cleaning and Maintenance	45
Section 3-3-1: Venting Layout: Wall Mounted Termination	17	General	45
Top Venting Graph P38, PL38:	17	Cleaning	45
Rear Venting Graph P38, PL38:	18	Replacing Light Bulbs	46
Top Venting Graph P42, PL42:	19	Troubleshooting	46
Rear Venting Graph P42, PL42:	20	Replacement Parts.....	47
Top Venting Graph (5"/8") P52, PL52:	21	Appendix A: Venting Terminations	48
Top Venting Graph (5"/10") P52, PL52:	22	Appendix B: Warranty	49
45° Corner Installation 5"/8":.....	23	Appendix B: Warranty Continued	50
45° Corner Installation 5"/10":.....	23	Appendix C: Amendment (Gas Fireplace / Equipment sold in the State of Massachusetts).....	51
45° or less Corner Installation 5"/8":.....	23	Indoor fireplace in protected outdoor applications	52
45° or less Corner Installation 5"/10":	23		
Section 3-3-2: Venting Components.....	24		
Section 3-3-2.2: Alternate Venting Components.....	25		
Flexmaster as alternate venting	26		
Section 3-3-3: Heat Shields 5"/8"	27		
Heat Shields 5"/10" (For P52DF and PL52DF).....	28		
Section 4: Wiring	29		
Installation of Electrical Supply	29		
Installation of the wall switch.....	30		
POD - Pilot on Demand	31		
What is POD and CPI mode?	31		
Remote Continuous Pilot (CPI) Selection	31		
Installing the CPI Jumper Cable.....	31		
Section 5: Installing the gas line.....	32		

Section A: Before You Begin

IMPORTANT MESSAGE: SAVE THESE INSTRUCTIONS

The Phenom Series fireplaces must be installed in accordance with these instructions. Carefully read all the instructions in this manual first. Consult the Local Gas Branch to determine the need for a permit prior to starting the installation. It is the responsibility of the installer to ensure this fireplace is installed in compliance with the manufacturers instructions and all applicable codes.

NOTICE

Do not use this appliance if any part has been under water. Immediately call a qualified service technician to inspect the appliance and to replace any part of the control system and any gas control that has been under water

NOTICE

Due to high temperatures, the appliance should be located out of traffic and away from furniture and draperies

NOTICE

Children and adults should be alerted to the hazards of high surface temperature and should stay away to avoid burns or clothing ignition

NOTICE

A barrier designed to reduce the risk of burns from the hot viewing glass is provided with this appliance and shall be installed for the protection of children and other at-risk individuals

Installation Checklist

- Determine the desired install location of your fireplace.
- See Section 1, Dimensions on Page 7, and refer to the Framing Section 2 for details.
- Select the location of your termination and resulting vent run.
- Your selected termination location must be the highest point in the Direct Vent installation.
- Should it be impossible to meet the venting requirements laid out in Section 3: Venting, please contact your Montigo dealer regarding the use of a Montigo Power Vent.
- Lay out the Vent run; calculating the required elbows and straight runs of 5"/8" flex and/or rigid pipe (5"/10" for P52 and PL52).
- Layout Electrical Requirements refer to Section 4: Wiring, for Details.
- Refer to Section 5: Installing the Gas Line, for details on the gas connection and access.
- Refer to local codes and guidelines for installation requirements.
- Installation and repairs should be done by a qualified contractor and must conform to:
- Installations in Canada must conform to the local codes or in the absence of local codes to the current version of Natural Gas and Propane Installation Code, CSA B149. Electrical installations must conform to the local codes or, in the absence of local codes, to the current version of Canadian Electrical Code, CSA C22.1.1
- Installations in the USA must conform to the local codes or in the absence of local codes to the current version of National Fuel Gas Code, ANSI Z223.1/NFPA 54. Electrical installations must conform to the local codes or, in the absence of local codes, to the current version of the National Electrical Code, ANSI/NFPA 70. See Appendix C for installation within the State of Massachusetts

NOTICE

Clothing or other flammable material should not be placed on or near the appliance

NOTICE

Installation and repair should be done by a qualified service person. The appliance should be inspected before use and at least annually by a professional service person. More frequent cleaning might be required due to excessive lint from carpeting, bedding material, etc. It is imperative that control compartments, burners, and circulating air passageways of the appliance be kept clean

Standard Installation Checklist

This standard installation checklist is to be used by the installer in conjunction with, not instead of, the instructions contained within this installation manual.



Customer _____ Install Address: _____ _____ Model (circle one): P38DFN-F, P38DFL-F, PL38DFN-F, PL38DFL-F, P42DFN-F, P42DFL-F, PL42DFN-F, PL42DFL-F, P52DFN-F, P52DFL-F, PL52DFN-F, PL52DFL-F	Date Installed: _____ Location of Fireplace: _____ Installer: _____ Dealer Phone: _____ Serial #: _____
---	---

	YES	NO	IF NO, WHY NOT?
Appliance Install: Section 2			
Framing complies with install manual.			
Standoffs have been installed.			
Proper clearances have been maintained.			
Venting: Section 3			
Venting configuration complies with vent diagrams.			
Venting installed, fastened, and secured in place maintaining proper clearance.			
Firestops installed.			
Exterior wall/roof flashing installed and sealed in compliance with local building code.			
Terminations installed and sealed in compliance with local building code.			
Direct vent termination is highest point in vent assembly.			
Wiring/Electrical: Section 4			
Unswitched power provided to the appliance PPO box.			
Low voltage wire connected to dry contact wall switch (non-powered)*			
Gas: Section 5			
Proper appliance for fuel type.			
Was a conversion performed?			
Leak check performed & inlet pressure verified.			
Finishing: Section 6			
Only non-combustible materials installed in non-combustible areas.			
Clearances meet installation manual requirements			
Mantels and/or projections comply with install manual			
Appliance Setup: Section 7 through 9			
Media, door, and screen installed according to install manual			
Manual given to home owner.			
Started appliance and verified no gas leaks exist.			
Comments:			

*Only applicable for PL Series

Rating Plate Sample

**Do Not Remove
This Label
N'enlevez Pas
Cette Etiquette**

Type: Vented Gas Fireplace Heater

Model No. Modèle: PL52DF

Serial No.: 2-170811-XXXXXX

Manufacturer / Fabricant: Canadian Heating Products Inc., Langley BC, (www.montigo.com)
Montigo DelRay Corp., Ferndale, WA, (www.montigo.com)

Tested To / Examiné À: CSA/ANSI Z21.88-2019 / CSA2.33-2019

Electrical Rating / Estimation Électrique: 115V / 1Ph / 60Hz / less than 12A

Altitude Rating / Estimation D'Altitude: N & H (0 - 4500 ft. / 0 - 1371 m.)

Fuel Type / Type De Carburant:

Natural Gas / Gaz Naturel

Propane / Gaz Propane

For Indoor Use Only

Not for use with solid fuel. / Pas pour l'usage avec le combustible solide.
Not for use with air filters. / Pas pour l'usage avec des filtres à air.

Max. Input Max. Entrée BTU/H	Min. Input Min. Entrée BTU/H	Output / Rendement BTU/H	Orifice Size / Taille D'Orifice Front/Avant Rear/Dernière
40,000	40,000	N/A	3@50 DMS / N/A
40,000	40,000	N/A	3@57 DMS / N/A

*Clearance to Combustibles *Dégagements Aux Combustibles	
Sides/Côtés:	2 1/2"
Back/Dernière:	1"
Top-Top Vent/Du Haut-Évent Du Haut:	26"
Top-Rear Vent/Du Haut-Évent Arrière:	12"
Floor/Plancher:	0"
Mantel/Manteau:	6"
Recess Depth/ Profondeur D'Encadrement:	25"
RV- Back:	3"

FOR USE WITH GLASS DOORS AND SCREENS CERTIFIED WITH THE APPLIANCE ONLY
Pour utilisation avec portes de verre and écrans de certifiés avec l'appareil seulement

***Refer to installation manual for more information.**
***Référez-vous au manuel d'installation pour plus d'information.**

Figure 1.1 Rating Plate for PL52

Section 1: Product Dimensions

P/PL 38 Dimensions

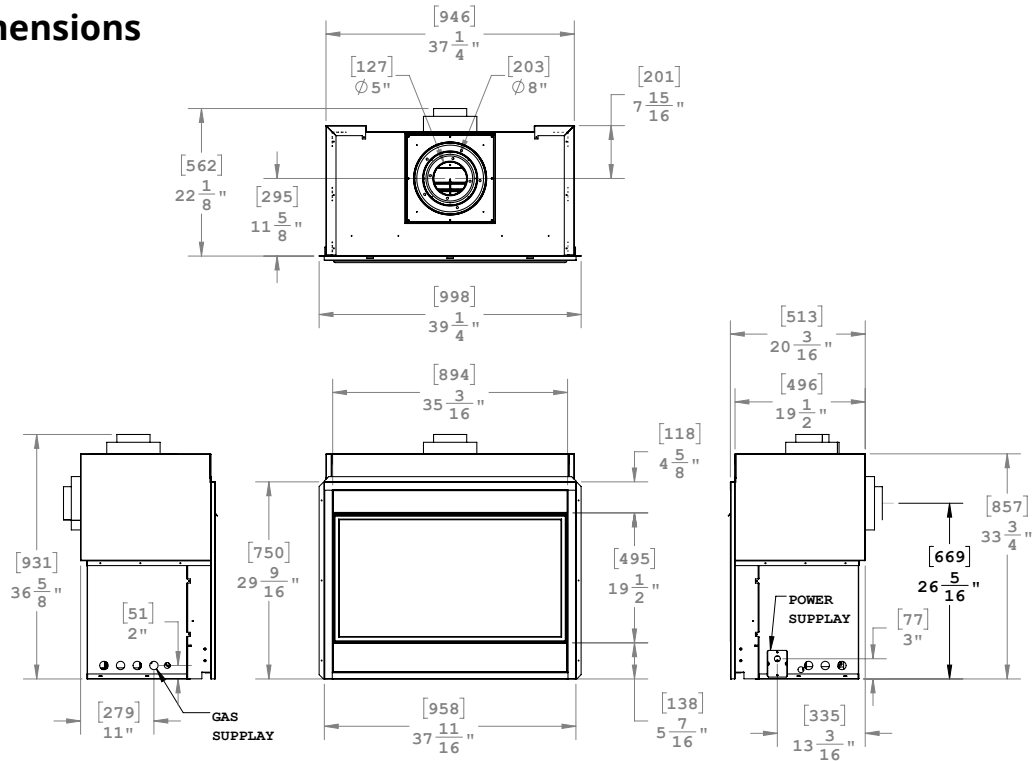

P/PL 42 Dimensions

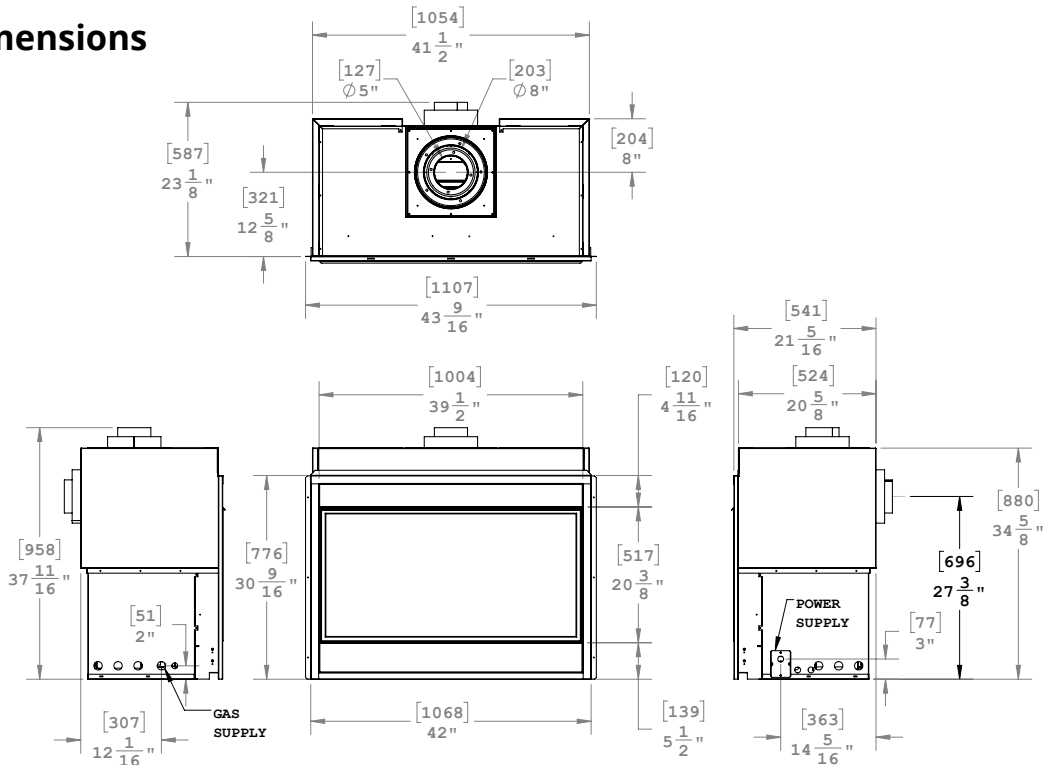

P/PL 52 Dimensions

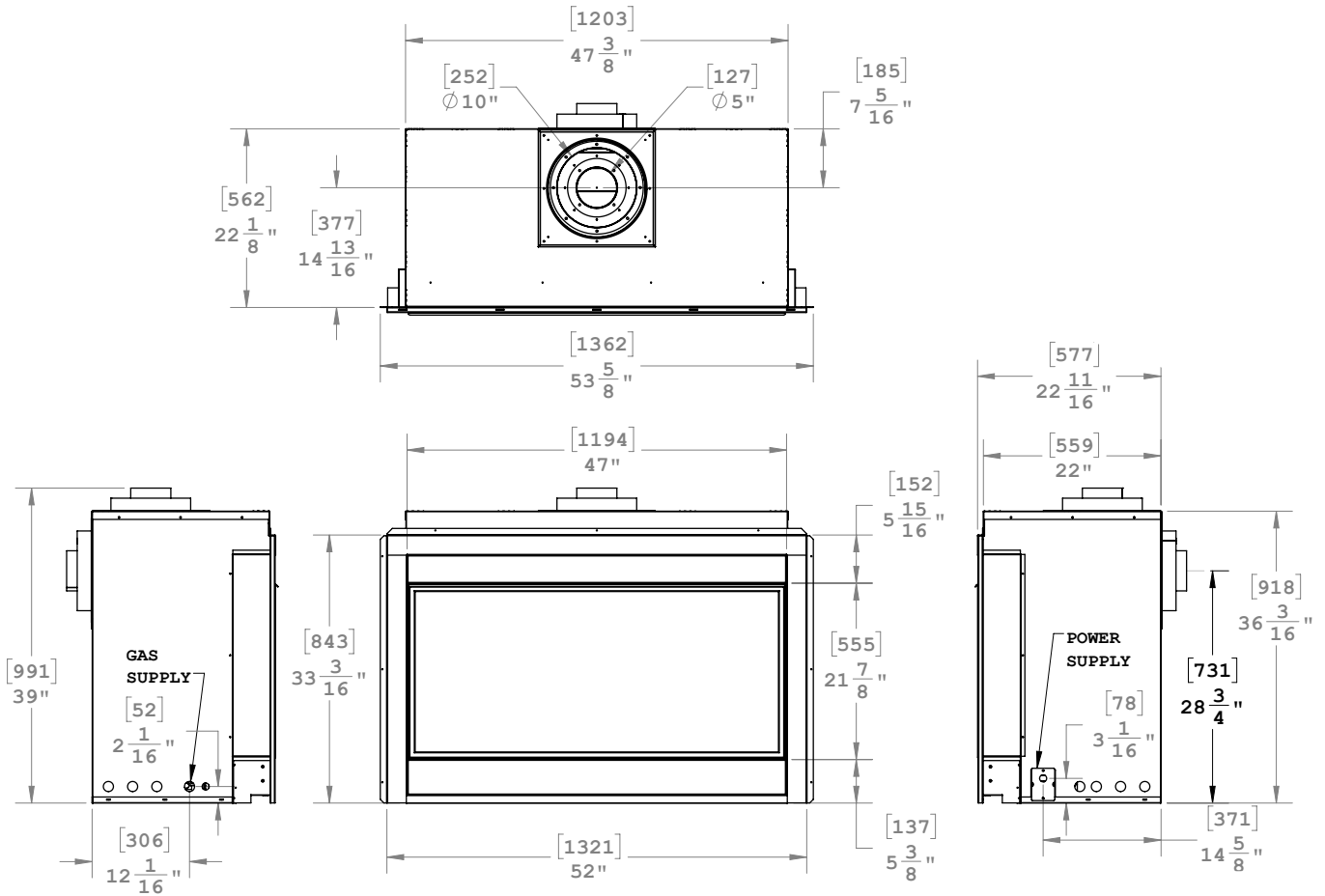

Figure 2. Fireplace dimensions (Tolerance $\pm 1/16$ ").

Section 2: Framing

In Wall and Corner Dimensions

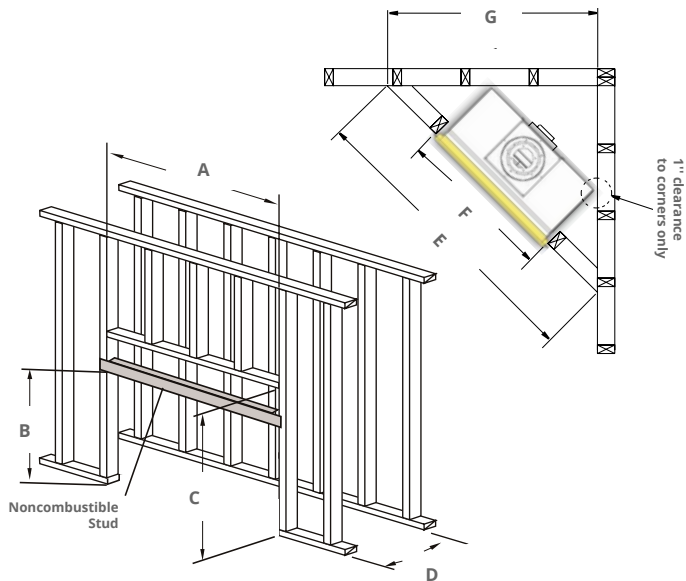

Figure 3.b Framing dimensions (Straight wall & Corner Installation).

P38, PL38	
A	37 ¾"
B	34 ¼"
C	41 ¼"
D	20 ⅞"
E	76 ¼"
F	37 ¾"
G	53 ⅞"

NOTE: When constructing the framed opening, please ensure there is access to install the gas line when the unit is installed.

P42, PL42	
A	42"
B	35"
C	42"
D	21 ⅞"
E	84 ½"
F	42"
G	59 ¾"

P52, PL52	
A	52"
B	37 ½"
C	43 ¾"
D	24 ½"
E	98"
F	52"
G	64 ¼"

⚠ WARNING

When this appliance is installed directly on ANY combustible other than wood flooring (carpet, vinyl, etc.). It must be installed on an equivalent wood or metal panel. This material must extend the full width and depth of the appliance.

NOTICE

Clearances must be in accordance with local installation codes and the requirements of the gas supplier

Alcove Dimensions

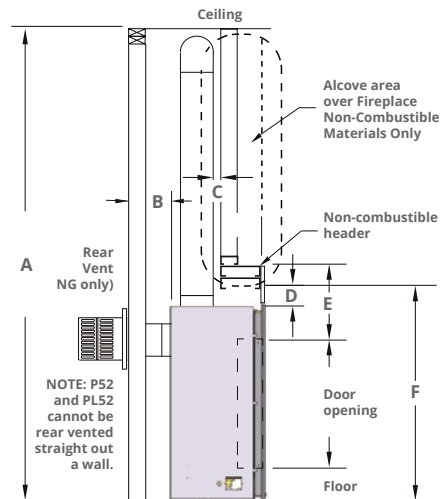

Figure 3.b.b Non Combustible Framing for Top Vent or Rear Vent, with alcove.

P38, PL38, P42, PL42	
A	96" MIN
B	12" MAX
C	1" MIN
D	3"
E	12"
F	37 ⅞"

P52, PL52	
A	84" MIN
B	N/A
C	1" MIN
D	1 ¼"
E	11½"
F	39 ¼"

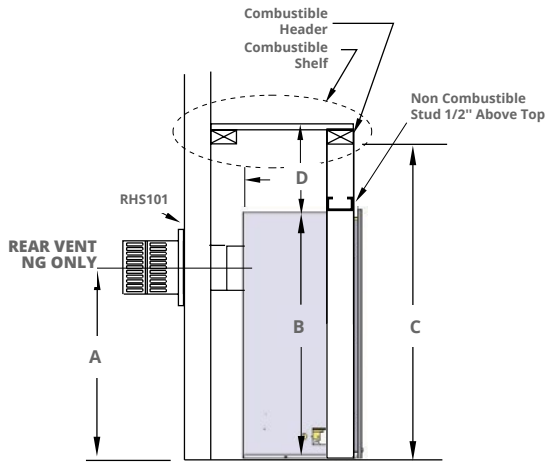

Figure 3.c Combustible Framing for shelves over the fireplace, Rear vent.

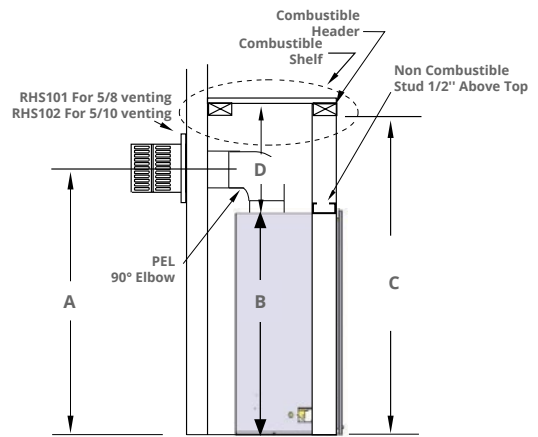

Figure 3.d Combustible Framing for shelves over the fireplace, Top vent.

P38, PL38	
A	26 $\frac{3}{8}$ "
B	33 $\frac{3}{4}$ "
C	41 $\frac{1}{4}$ "
D	9"

P42, PL42	
A	27 $\frac{1}{2}$ "
B	34 $\frac{1}{2}$ "
C	42"
D	9"

P52, PL52	
P52 and PL 52 cannot be rear vented straight out a wall.	

P38, PL38	
A	39"
B	33 $\frac{3}{4}$ "
C	49 $\frac{3}{4}$ "
D	17 $\frac{1}{2}$ "

P42, PL42	
A	40 $\frac{1}{2}$ "
B	34 $\frac{1}{2}$ "
C	50 $\frac{1}{2}$ "
D	17 $\frac{1}{2}$ "

P52, PL52	
A	56" min
B	36 $\frac{1}{4}$ "
C	62 $\frac{1}{4}$ "
D	26" min

Clearances:

P38, PL38, P42, PL42:

When installing a shelf over the top of the fireplaces, the following guidelines must be adhered to:

For Rear Vent applications, the minimum clearance is 0" from the rear of the fireplace to a wall, or any combustible materials, and 9" clearance from the top of the fireplace to the underside of any combustible shelf materials.

For Top Vent applications, the minimum clearance is 0" from the rear of the fireplace to a wall, or any combustible materials, and 17 1/2" to the underside of any combustible shelf materials.

P52, PL52:

When installing a shelf over the top of the fireplaces, the following guidelines must be adhered to:

For Rear Vent multi-elbow applications, the minimum clearance is 1" from the elbow off the rear of the fireplace to a wall, or any combustible materials, and 12" clearance from the top of the fireplace to the underside of any combustible shelf materials.

For Top Vent applications, the minimum clearance is 1" from the rear of the fireplace to a wall, or any combustible materials, and 26" to the underside of any combustible shelf materials.

MODEL	Top - Rear vent †	Top - Top vent †	Rear	Sides	Floor††	Mantel	Vent Pipe
P38DF* PL38DF*	9"	17 1/2"	0"	0"	0"	See Section 6 Finishing around the fireplace	1" all around 2" on the horizontal
P42DF* PL42DF*	9"	17 1/2"	0"	0"	0"	See Section 6 Finishing around the fireplace	1" all around 2" on the horizontal
P52DF* PL52DF*	12"	26"	1"	2 1/2" †††	0"	See Section 6 Finishing around the fireplace	1" all around 2" on the horizontal

Figure 4. Combustible Wall Clearances

NOTES:

† Clearance from top of fireplace to a ceiling within the fireplace enclosure.

†† Four sided surrounds require a raised installation.

††† 2 1/2" clearance is from the main body of the firebox, NOT the insulated flange. Clearance to the insulated flange is 1".

NOTICE

Do not install nailing flange when installing a Montigo surround, use equivalent non-combustible.

Installing The Standoffs

To avoid elevated mantel temperatures, all Phenom gas fireplaces are required to have the supplied standoffs installed. The fireplace is supplied with two standoffs. Bend and install these standoffs on top of the fireplace ensuring that the height of the standoff maintains a 7 1/2" clearance.

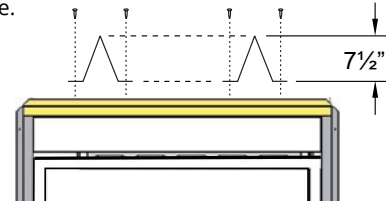

Figure 4.b Installing standoffs

Installing the Nailing Flange Extension

Before installing the supplied nailing flange extension, fold tabs at bottom of nailing flange to a 90 degree angle. **NOTE:** Do not install nailing flange when installing a Montigo Surround.



Figure 4.c Bottom of Nailing Flange Extension



Figure 4.d Bottom of Nailing Flange Extension with tab folded at 90 degree angle



Figure 4.e Insert folded tabs into slots above the front of the fireplace

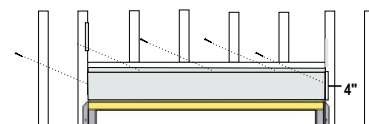

Figure 4.f Securing the Nailing Flange Extension.

The supplied nailing extension must be placed along the top edge of the fireplace and securely fastened into place, as shown in figure 4.c. Note: The nailing flange extension can be substituted with a piece of **NON-COMBUSTIBLE** material of the same size and thermal characteristics, ie: cement board or equivalent.

Section 3: Venting

Montigo supplies a variety of direct venting and termination options. The direct vent termination location **MUST** be selected such that it is the highest point in the venting assembly. It should also be selected such that it provides the shortest vent run possible. Should it be impossible to ensure that the termination is the highest point or to meet the venting guidelines laid out below please contact your Montigo dealer to discuss power venting options.

Notes For Planning Venting:

- Venting can originate from the unit through the top or through the rear
- Venting can terminate through the roof or through an exterior wall.
- Refer to Appendix A - Termination Locations to ensure the planned termination location is acceptable.
- Once the termination location has been established, refer to the appropriate section below for installation details
- All fireplaces shipped from the factory are top vent.
- **Silicone** application is **NOT** required when joining Montigo vent pipes and components.

Section 3-1: Converting to Rear Vent

Use the following instructions to convert a unit for Rear Vent use:

1. Remove the rear flue cover and gasket (5" and 8") on the flue outlet, as shown in Figure 5.
2. Next, remove the top flue collar (5" and 8") on the flue outlet, as shown in Figure 5.
3. Install the (removed) rear flue cover and gasket material, to the top vent outlet. Fasten the cover with included hardware, as illustrated Figure 5.b
4. Install the (5" and 8") collars to the rear vent outlet using the included hardware, as illustrated Figure 5.b

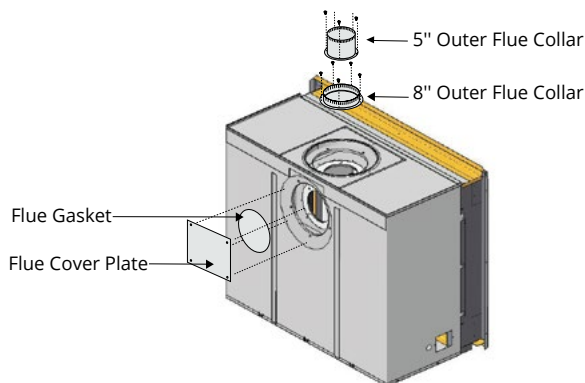

Figure 5. Flue cover and collar removal, Top Vented fireplace.

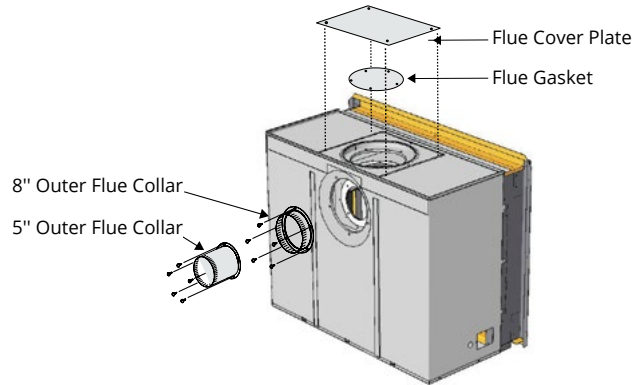

Figure 5.b Flue cover and collar installation, Rear Vented fireplace.

Section 3-1-1: Converting to 5" / 8" Venting (For P52, PL52)

P52 AND PL52 UNITS CANNOT BE REAR VENTED STRAIGHT THROUGH THE WALL. REAR VENT APPLICATIONS MUST BE MULTI-ELBOW.

(VERTICAL VENT RUNS OVER 8' FROM TOP OF UNIT ONLY)

1. Use the following instructions to convert a PL52DF* and P52DF* from 5"/10" to 5"/8" venting for top vent use figure 6.e on page 13.
2. Remove the 10" outer flue collar on the flue outlet, from the desired vent start - TOP or REAR
3. Install the separately ordered 8" reducing collar (RVA108) on the Top or Rear vent outlet.

NOTE: If power venting, vent run must be reduced to 5"/8" or 4"/7". contact your Montigo dealer to discuss power venting options.

NOTICE

Under no circumstances can Montigo flex venting be cut to accommodate an installation. Use an alternative length to complete your vent run.



Section 3-2: Installing a Roof Mounted Direct Vent Termination for 5" / 8" (PVTk1SS)

This section applies to installations where the direct vent termination will be roof mounted.

Section 3-2-1: Venting Layout

Selection of components and details of venting lay out should adhere to the following guidelines:

- The maximum termination point is 32' above the fireplace (**NOTE:** if the maximum termination height is used, the flame pattern may be affected).
- The vertical termination must be a minimum 2' higher than where the termination exits the roofing materials, (asphalt shingles, cedar shakes, etc). This distance should be measured from the high side of the roof slope where the flue flashing intersects the roofing materials.
- Termination location must be a minimum 6' from a mechanical air inlet.
- 1" clearance is maintained on sides and bottom of vent runs and 2" above horizontal vent runs to any combustible material.
- For a more detailed diagram of allowed termination locations, see Appendix A.
- A maximum of two offsets (each offset is made up of 2-90° bends) may be made for vertical vent runs.
- Firestops must be installed as required by national & local codes
- Ensure all horizontal runs are supported with a minimum of 3 supports per 10' of venting.
- Install all roof flashing and storm collars as shown.

Roof mounted terminations

The following details are some possible configurations for roof mounted terminations. See below.

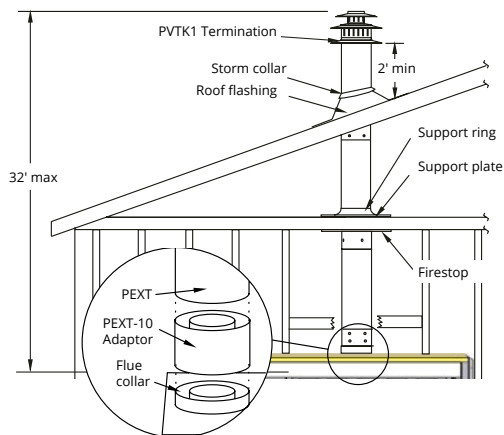

Figure 6. Top vent, roof mounted termination with no offset in vent run.

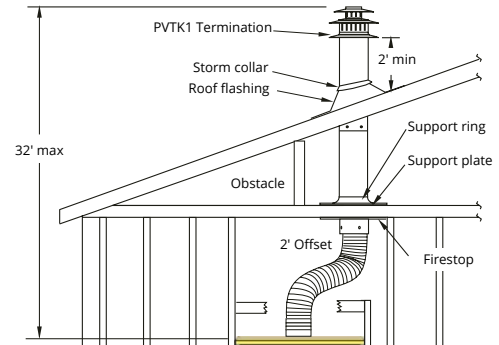

Figure 6.b Top vent, roof mounted with 1 offset (1 offset= two 90° bends).

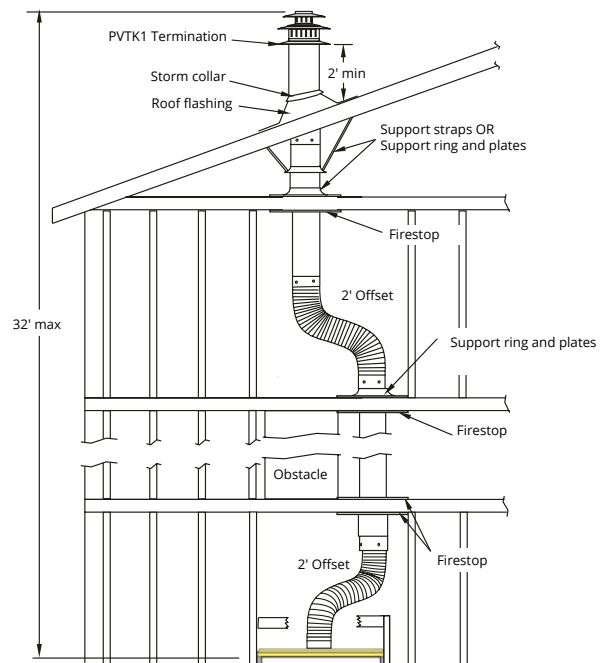

Figure 6.c Top vent, roof mounted with 2 offsets (1 offset= two 90° bends).

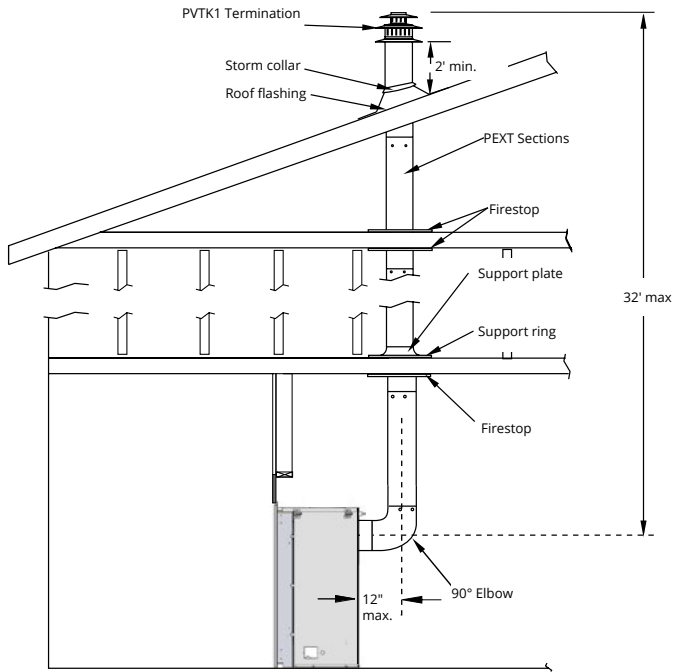

Figure 6.d Rear vent, roof mounted venting (1 = 90° bend).

5" / 8" Piping for P52 and PL52 units

FOR USE OF 5" / 8" PIPING YOU MUST HAVE A MINIMUM VERTICAL RISE OF 8 FEET FROM THE TOP OF THE UNIT.

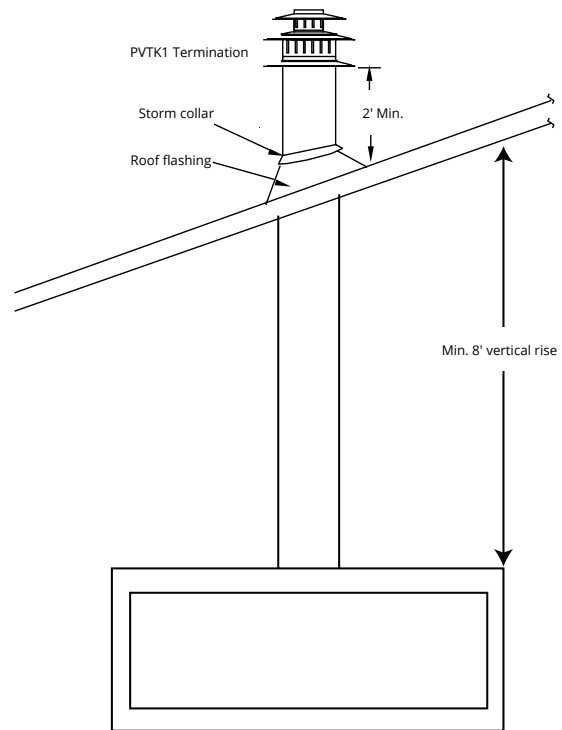

Figure 6.e 5"/8" piping for P-PL52 units

This configuration allows for 5" and 8" piping and termination

Component	Part Number
Reducing Collar	RVA108
Rigid straight pipe	PXT or PEXT
Termination	PVTk1SS
Heat Shield*	RHS101

* Heat Shield RHS101 required if vent passes through wall or ceiling

Section 3-3: Installing a Wall Mounted Termination 5"/8"

This section applies to installations where the direct vent termination will be wall mounted. **NOTE:** If subject to a highly corrosive environment i.e. Seaside, Montigo recommends using Stainless Steel Termination.

Installation of termination with built in frame

A termination with a built-in frame is installed during framing of a structure.

1. Frame the termination opening to 11" x 11".
2. Install exterior sheathing to the structure framing.
3. Fasten the termination to the sheathing using a minimum of 4 screws.

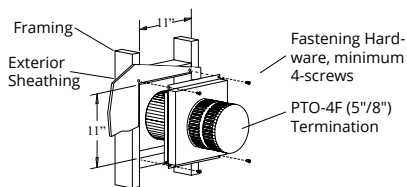

Figure 7. Installing a PTO-4F termination.

Installation of termination frame at time of framing

Terminations with a MSR frame allow the installation of the frame prior to installation of the termination.

1. Frame the termination opening to 12" x 12".
2. Secure the MSR Frame to the exterior sheathing of the structure.
3. Fasten the termination to the MSR Frame using a minimum of 4 screws.

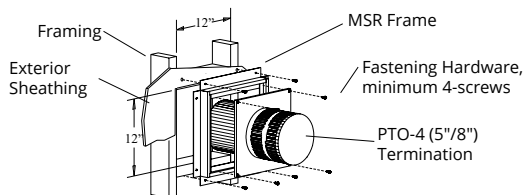

Figure 7.b Installing a PTO termination with the MSR frame.

Installation of termination frame at time of framing in masonry

Terminations with a BSR frame allow the installation of the frame in masonry prior to the installation of the termination

1. Frame the BSR opening to 12" x 12".
2. Secure the BSR Frame to the exterior sheathing of the structure.
3. Fasten the termination to the BSR Frame using a minimum of 4 screws.

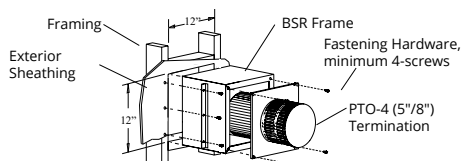

Figure 7.c Installing a PTO termination with the BSR frame.

Installation of termination from inside structure

A Termination with a MOSR Frame is installed from the inside of the structure. These are commonly used in high-rise construction.

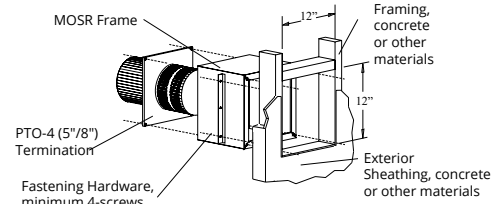

Figure 7.d Installing a PTO termination with MOSR frame.

1. Frame the MOSR opening to 12" x 12".
2. Fasten the MOSR frame to the interior side of the studs, concrete, or finished wall construction using a minimum of 4 screws.
3. Insert the termination into the MOSR frame as shown here, (from the inside) and attach to the MOSR by installing a min. quantity of 4 bolts into the threaded nuts on the MOSR Frame.

Installation of a termination shield for vinyl siding

The VSS Termination shield is installed when the exterior of a structure is clad with Vinyl siding. It is placed directly above, and on-center with the termination.

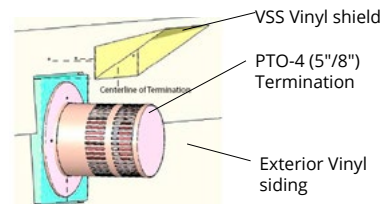

Figure 7.e Installing the VSS Vinyl Shield.

Installing heat guards

Installing heat guards over terminations is recommended in installations where the termination is located within 7' feet above grade, or above a pedestrian walkway, and may be required by code in public areas.

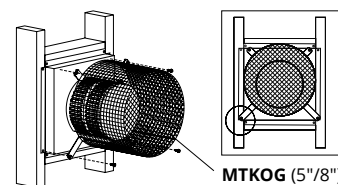

Figure 7.f Installing a PTO termination heat guard.

1. Ensure that the two long mounting brackets are facing the bottom of the termination (See inset). This will provide more heat protection at the top of the termination, where temperatures are highest.
2. Attach to the faceplate of the termination using four sheet metal screws.

Installing a Wall Mounted Termination 5"/10"

FOR P52 AND PL52 UNITS ONLY

This section applies to installations where the direct vent termination will be wall mounted. **NOTE:** If subject to a highly corrosive environment i.e. seaside, Montigo recommends using stainless steel termination.

Installation of termination with built in frame under 8' from the top of the unit.

A Termination with a built-in frame is installed during framing of a structure.

1. Frame the termination opening to 16" x 16".
2. Install exterior sheathing to the structure framing.
3. Fasten the termination to the sheathing using a minimum of 4 screws.

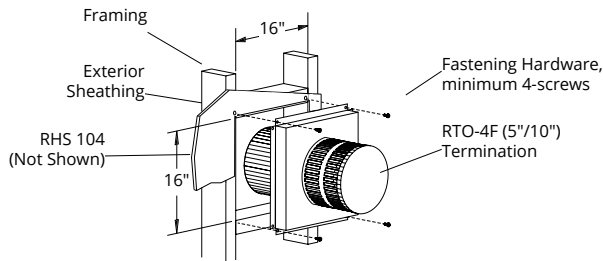

Figure 7.g Installing a RTO-4F termination.

Section 3-3-1: Venting Layout: Wall Mounted Termination

Top Venting Graph P38, PL38:

Measure the vertical height from the fireplace hearth to the centre of the termination and the horizontal run from the fireplace flue collar to the wall flange of the termination. Plot on the Venting Graph Figure 8 or 8b with an 'X'.

If the 'X' falls on or above the top boundary of the shaded area, the installation is acceptable.

Selection of components and details of venting layout should adhere to the following guidelines:

- Vent terminations must not be recessed in walls or siding.
- For Heat Shield requirements see Section 3-3 on page 14.
- Once the proposed venting layout has been determined refer to Figure 8, 8b, 8c to ensure the layout is acceptable.

Notes Wall Mounted Terminations: TOP VENT

- All measurements for vertical or horizontal runs are measured from center of the vent pipe.
- Venting runs must fall within the limits set by the venting graph, see Figure 8 or 8b.

Wall mounted Terminations:

The following details are some possible configurations for Wall mounted terminations. See below.

Example A: (Acceptable Installation)

If the vertical dimension from the hearth is 120" and the horizontal run to the wall flange of the vent termination is 144", this would be an acceptable installation.

Example B: (Unacceptable Installation)

If the vertical dimension from the hearth is 36" and the horizontal run to the wall flange of the vent termination is 84", this would not be an acceptable installation.

Example C: (Unacceptable Installation)

If the vertical dimension from the floor of the fireplace is 60" and the horizontal run to the wall flange of the vent termination is 144", this would not be an acceptable installation.

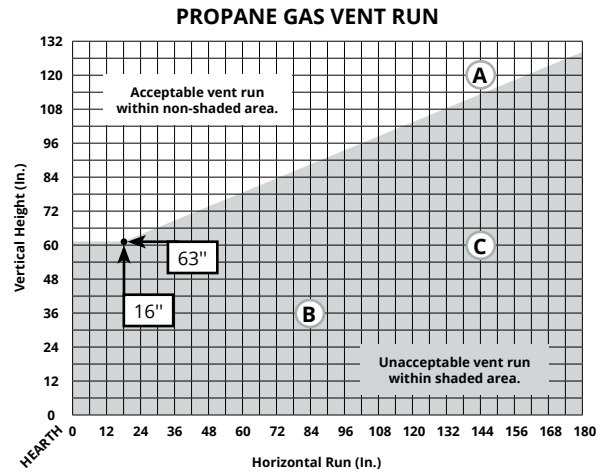

Figure 8. PL38DF* Propane Top Vent Venting Graph for wall mounted terminations.

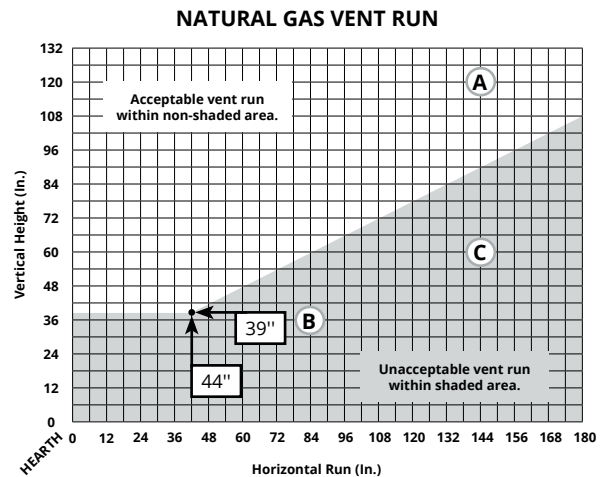

Figure 8.b PL38DF* NG Top Vent Venting Graph for wall mounted terminations.

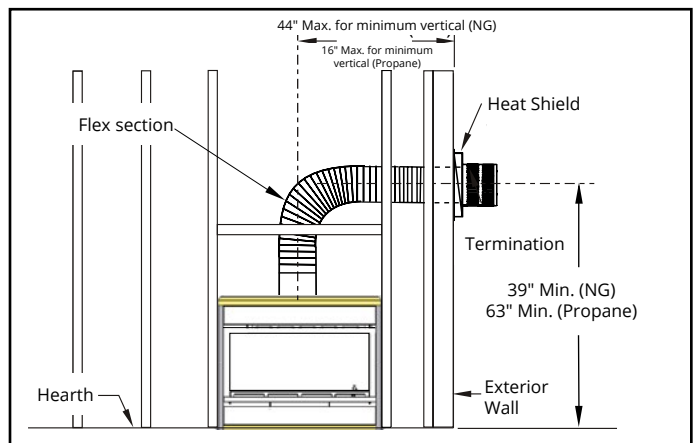

Figure 8.c Top Vented, wall mounted Multi-elbow installation. See Venting Graph for Top vent, wall mounted terminations, Figure 8 or 8.b

Rear Venting Graph P38, PL38:

Measure the vertical height from the fireplace hearth to the centre of the termination and the horizontal run from the fireplace flue collar to the wall flange of the termination. Plot on the Venting Graph Figure 9 or 9.b with an 'X'.

If the 'X' falls on or above the top boundary of the shaded area, the installation is acceptable.

Notes Wall Mounted Terminations: REAR VENT

- All dimension lengths for vertical or horizontal runs are measured from center of the vent pipe.
- Venting runs must fall within the limits set by the venting graphs, see Figure 9 or 9.b
- Fireplace must be converted to Rear Vent configuration prior to running vent, see Figure 5 and 5.b (Page 11)

Example A: (Acceptable Installation)

If the vertical dimension from the hearth is 120" and the horizontal run to the wall flange of the vent termination is 144", this would be an acceptable installation.

Example B: (Unacceptable Installation)

If the vertical dimension from the hearth is 36" and the horizontal run to the wall flange of the vent termination is 84", this would not be an acceptable installation.

Example C: (Unacceptable Installation)

If the vertical dimension from the floor of the fireplace is 60" and the horizontal run to the wall flange of the vent termination is 144", this would not be an acceptable installation.

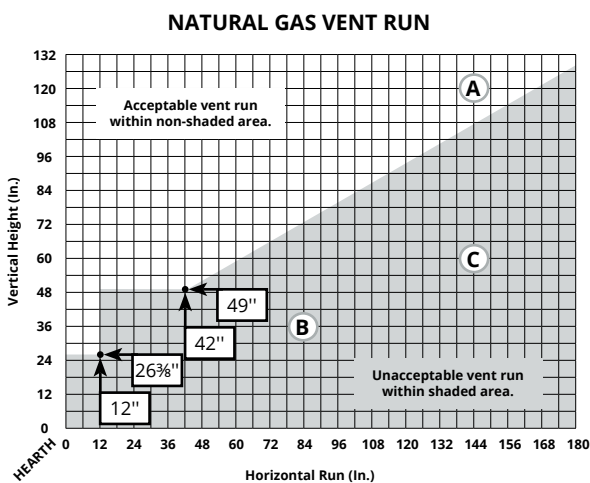

Figure 9. PL38DF* Rear Vent Venting Graph for NG wall mounted terminations.

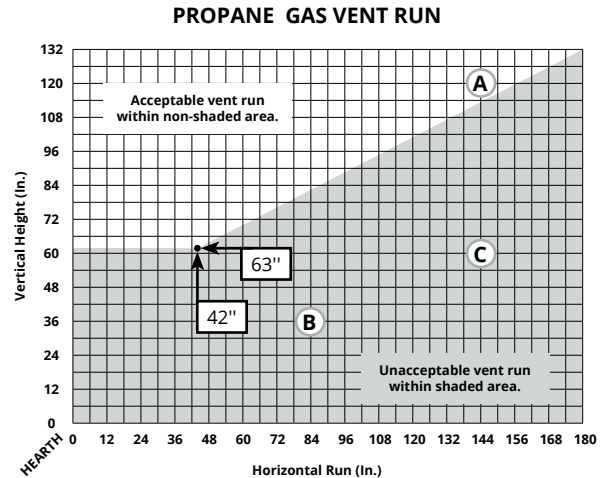

Figure 9.b PL38DF* Rear Vent Venting Graph for Propane wall mounted terminations.

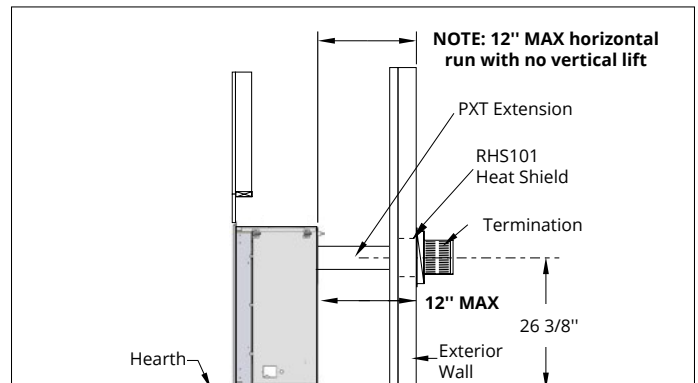

Figure 9.c Straight run, Rear Vented, wall mounted termination. Note: Straight through the wall rear vent available for Natural Gas only.

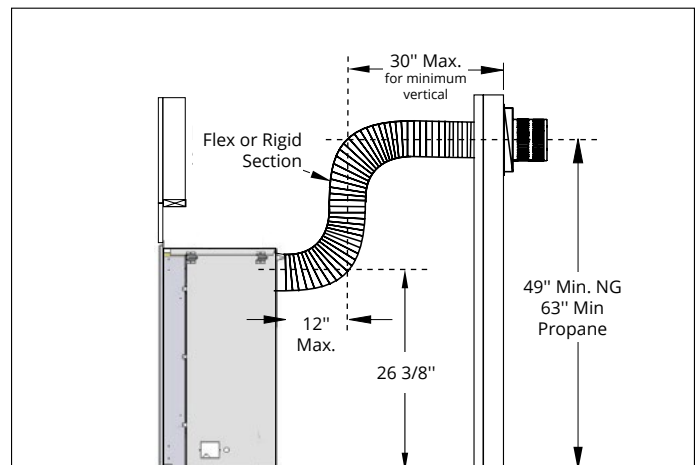

Figure 9.d Rear Vented, wall mounted Multi-elbow termination installation for NG or Propane. Installation must comply with the Venting Graph for Rear vent, wall mounted terminations, Figure 15 or 15a.

Top Venting Graph P42, PL42:

Measure the vertical height from the fireplace hearth to the centre of the termination and the horizontal run from the fireplace flue collar to the wall flange of the termination. Plot on the Venting Graph Figure 10 or 10.b with an 'X'.

If the 'X' falls on or above the top boundary of the shaded area, the installation is acceptable.

Notes Wall Mounted Terminations: TOP VENT

- All measurements for vertical or horizontal runs are measured from center of the vent pipe.
- Venting runs must fall within the limits set by the venting graph, see Figure 10 or 10b.

Example A: (Acceptable Installation)

If the vertical dimension from the hearth is 120" and the horizontal run to the wall flange of the vent termination is 144", this would be an acceptable installation.

Example B: (Unacceptable Installation)

If the vertical dimension from the hearth is 36" and the horizontal run to the wall flange of the vent termination is 84", this would not be an acceptable installation.

Example C: (Unacceptable Installation)

If the vertical dimension from the floor of the fireplace is 60" and the horizontal run to the wall flange of the vent termination is 144", this would not be an acceptable installation.

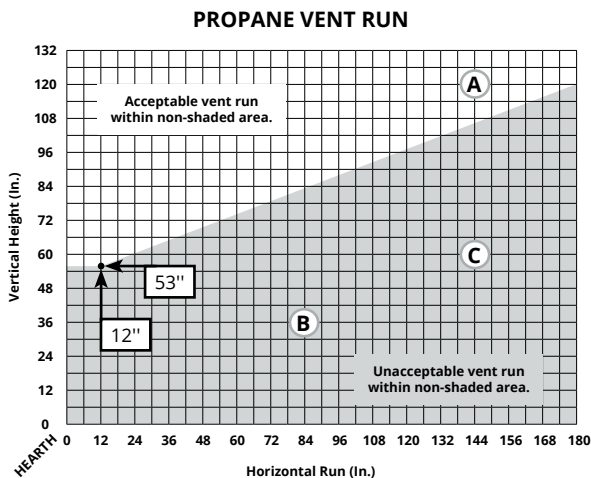

Figure 10. PL42DF* Propane Top Vent Venting Graph for wall mounted terminations.

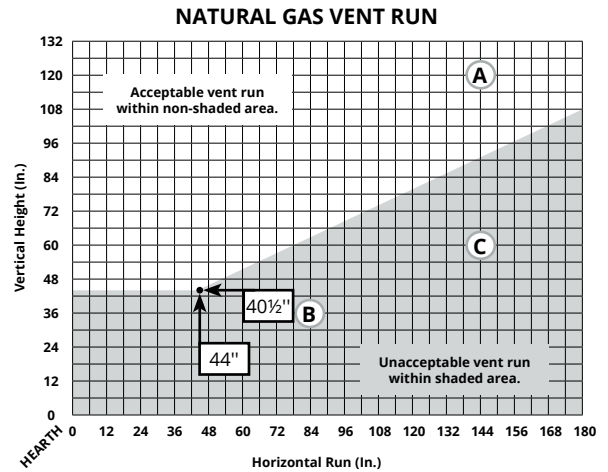

Figure 10.b PL42DF* NG Top Vent Venting Graph for wall mounted terminations.

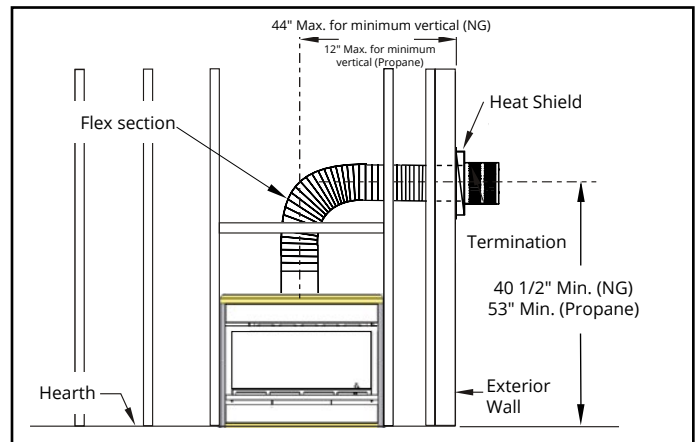

Figure 10.c Top Vented, wall mounted Multi-elbow installation. See Venting Graph for Top vent, wall mounted terminations, Figure 10 or 10b.

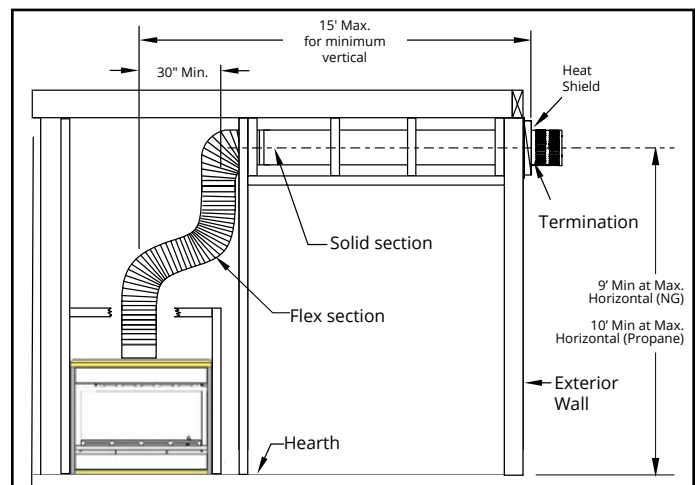

Figure 10.d Top Vented, wall mounted Multi-elbow installation. The vent run must comply with Venting Graph for Top vent, wall mounted terminations, Figure 10 or 10.b

Rear Venting Graph P42, PL42:

Measure the vertical height from the fireplace hearth to the centre of the termination and the horizontal run from the fireplace flue collar to the wall flange of the termination. Plot on the Venting Graph Figure 11 or 11.b with an 'X'.

If the 'X' falls on or above the top boundary of the shaded area, the installation is acceptable.

Notes Wall Mounted Terminations: REAR VENT

- All dimension lengths for vertical or horizontal runs are measured from center of the vent pipe.
- Venting runs must fall within the limits set by the venting graphs, see Figure 11 or 11.b
- Fireplace must be converted to Rear Vent configuration prior to running vent, see Figure 8 and 8a.

Example A: (Acceptable Installation)

If the vertical dimension from the hearth is 120" and the horizontal run to the wall flange of the vent termination is 144", this would be an acceptable installation.

Example B: (Unacceptable Installation)

If the vertical dimension from the hearth is 36" and the horizontal run to the wall flange of the vent termination is 84", this would not be an acceptable installation.

Example C: (Unacceptable Installation)

If the vertical dimension from the floor of the fireplace is 60" and the horizontal run to the wall flange of the vent termination is 144", this would not be an acceptable installation.

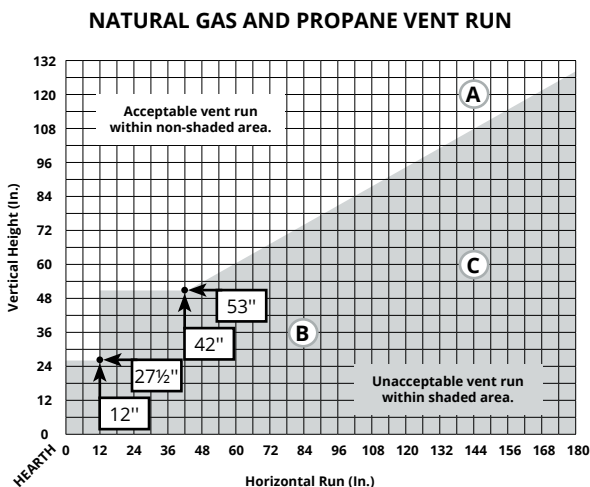

Figure 11. PL42DF* Rear Vent Venting Graph for NG and propane wall mounted terminations.

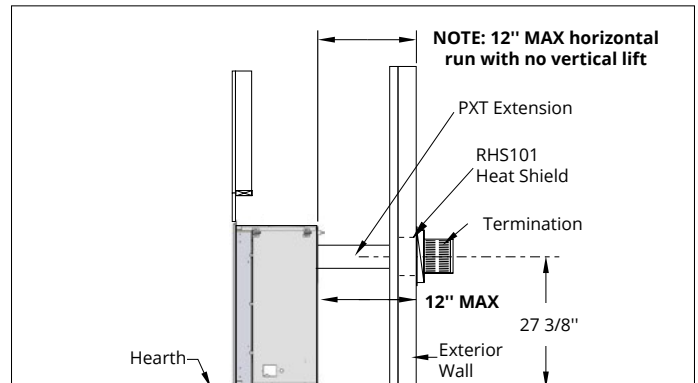

Figure 11.b Straight run, Rear Vented, wall mounted termination. The vent run must comply with the Venting Graph for Rear vent, wall mounted terminations, Figure 11. NOTE: Straight through the wall rear vent available for **Natural Gas** only.

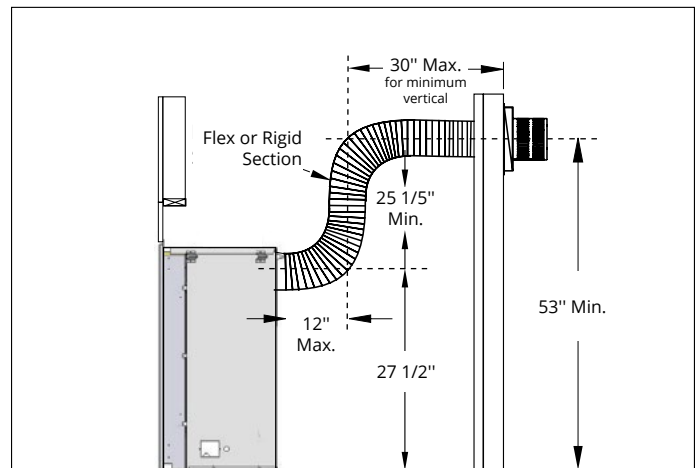

Figure 11.c Rear Vented, wall mounted Multi-elbow termination installation. The vent run must comply with the Venting Graph for Rear vent, wall mounted terminations, Figure 11.b

Top Venting Graph (5"/8") P52, PL52:

Measure the vertical height from the fireplace hearth to the centre of the termination and the horizontal run from the fireplace flue collar to the wall flange of the termination. Plot on the Venting Graph Figure 12 or 12b with an 'X'.

If the 'X' falls on or above the top boundary of the shaded area, the installation is acceptable.

Notes Wall Mounted Terminations: TOP VENT

- All measurements for vertical or horizontal runs are measured from center of the vent pipe.
- Venting runs must fall within the limits set by the venting graph, see Figure 12 or 12b.

Example A: (Acceptable Installation)

If the vertical dimension from the hearth is 180" and the horizontal run to the wall flange of the vent termination is 120", this would be an acceptable installation.

Example B: (Unacceptable Installation)

If the vertical dimension from the hearth is 126" and the horizontal run to the wall flange of the vent termination is 54", this would not be an acceptable installation.

Example C: (Unacceptable Installation)

If the vertical dimension from the floor of the fireplace is 125" and the horizontal run to the wall flange of the vent termination is 130", this would not be an acceptable installation.

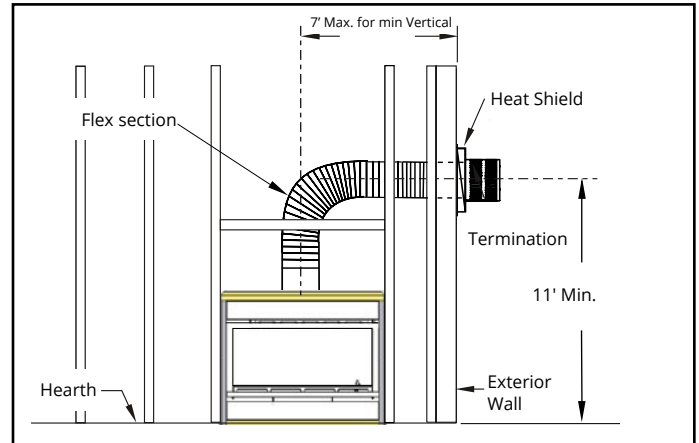

Figure 12.b 5"/8" Top Vented, wall mounted installation with one 90° bend. The vent run must comply with Venting Graph for Top vent, wall mounted terminations, Figure 12.

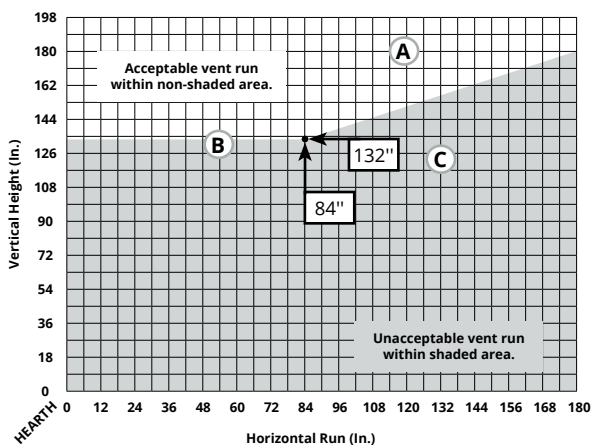

Figure 12. 5"/8" Top Vent Venting Graph for wall mounted terminations.

Top Venting Graph (5"/10") P52, PL52:

Measure the vertical height from the fireplace hearth to the centre of the termination and the horizontal run from the fireplace flue collar to the wall flange of the termination. Plot on the Venting Graph Figure 13 with an 'X'.

If the 'X' falls on or above the top boundary of the shaded area, the installation is acceptable.

Notes Wall Mounted Terminations: TOP & REAR VENT

- All dimension lengths for vertical or horizontal runs are measured from center of the vent pipe.
- Venting runs must fall within the limits set by the venting graphs, see Figure 13.
- Fireplace must be converted to Rear Vent configuration prior to running vent, see Section 3: Venting, figures 5 and 5b.

Example A: (Acceptable Installation)

If the vertical dimension from the hearth is 120" and the horizontal run to the wall flange of the vent termination is 138", this would be an acceptable installation.

Example B: (Unacceptable Installation)

If the vertical dimension from the hearth is 48" and the horizontal run to the wall flange of the vent termination is 72", this would not be an acceptable installation.

Example C: (Unacceptable Installation)

If the vertical dimension from the floor of the fireplace is 60" and the horizontal run to the wall flange of the vent termination is 144", this would not be an acceptable installation.

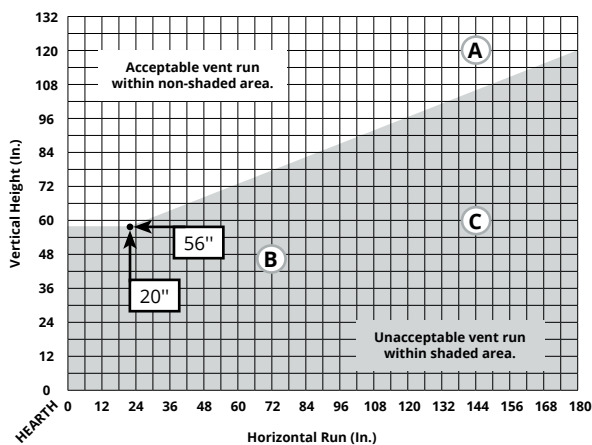

Figure 13. 5"/10" Top or Rear Vent Venting Graph for wall mounted terminations.

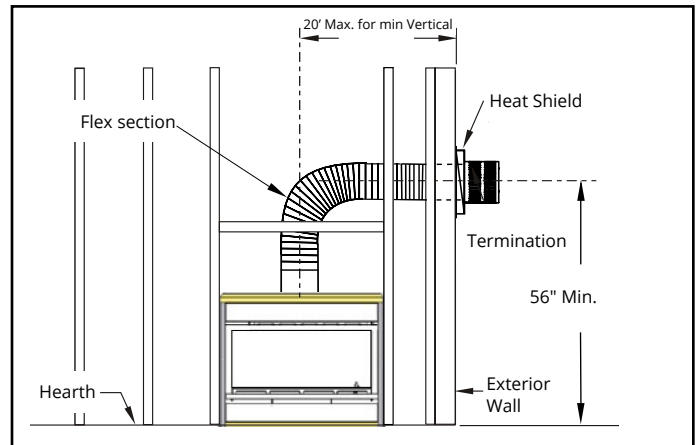

Figure 13.b 5"/10" Top Vented, wall mounted installation with one 90° bend. The vent run must comply with Venting Graph for Top vent, wall mounted terminations, Figure 12

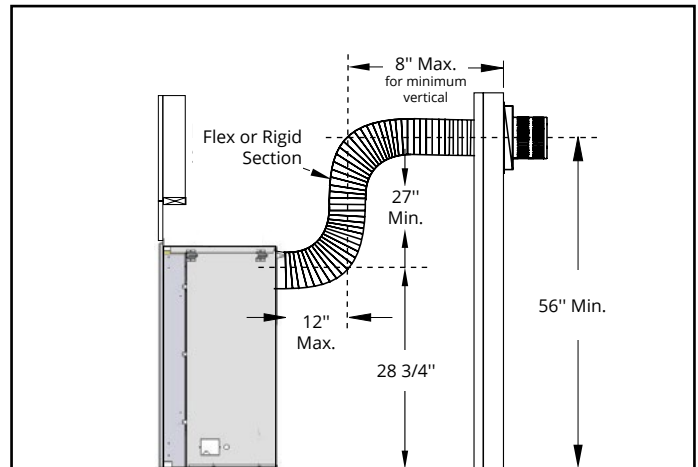

Figure 13.c 5"/10" Rear Vented, wall mounted Multi-elbow termination installation. The vent run must comply with the Venting Graph for Rear vent, wall mounted terminations

Note:

If power venting, vent run must be reduced to 5"/8" or 4"/7". Contact your Montigo dealer to discuss power venting options.

45° Corner Installation 5"/8":

Attach a PEL-45 (45° elbow) directly onto the flue collar. Cut the PXT-20 to suit, and attach it to the PEL-45. Slide the fireplace into position and attach to the termination.

45° Corner Installation 5"/10":

Attach a REL-45 (45° elbow) directly onto the flue collar. Cut the RXT-20 to suit, and attach it to the REL-45. Slide the fireplace into position and attach to the termination.

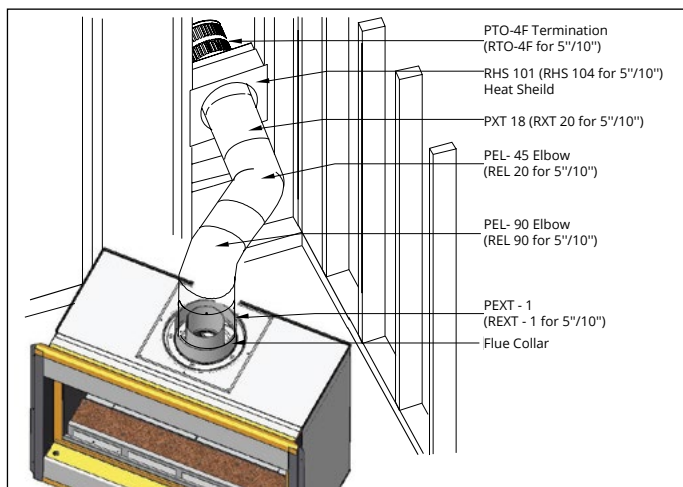

Figure 14. Corner Installation

45° or less Corner Installation 5"/8":

Use a PTO-4 termination and a PFL-1 or PFL-2 (12" or 24" compressed length) and a frame, if appropriate. Flex may be turned to obtain desired degree of angle required but must not exceed 45°.

45° or less Corner Installation 5"/10":

Use a RTO-4 termination and a RFL-4 (48" compressed length) and a frame, if appropriate. Flex may be turned to obtain desired degree of angle required but must not exceed 45°.

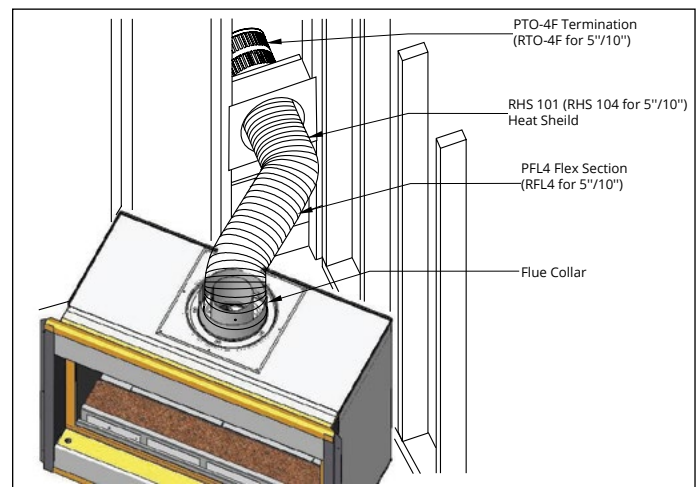

Figure 14.b Corner Installation Flex

NOTICE

Corner Installation is available for **TOP VENT UNITS ONLY**. Ensure minimum Vertical Venting Height is maintained in corner installations:

- 40" for P*38
- 48" for P*42
- 56" for P*52

NOTE: P*38DF, P*42DF: The PFVK01 / PFVK01F kit is available for top vent corner FLEX application (NG only). The kit includes a heat shield, a PFL-18 (f/f) flexible pipe, and a termination with or without a mounting frame.

NOTE: P*52DF: The PFVK01F kit is available for top vent corner FLEX application (NG only). The kit includes a heat shield, a RFL-2 (f/f) flexible pipe, and a termination with or without a mounting frame.

Section 3-3-2: Venting Components

The following components and associated Montigo part numbers are for installation of a roof or wall mounted termination. Use of non-Montigo approved parts will VOID the warranty and may impede operation of the fireplace.

A - Termination	RTO4F (5/10 Vent) PTO4F (5/8 Vent) PTO4 (5/8 Vent) PVTK1SS (5/8 Vent)
B - Frame Kits	MSR (Stucco Frame) MOSR (Stucco Frame) BSR-4 (4" Brick Frame) BSR-6 (6" Brick Frame)
C - Flex Sections (5/8 Vent)	PFL - 1 (12" f/f Section) PFL - 18 (18" f/f Section) PFL - 2 (24" f/f Section) PFL - 3 (36" f/f Section) PFL - 4 (48" f/f Section) PFL - 6 (72" f/f Section)
D - Rigid Sections (5/8 Vent)	PXT - 5 (5" f/f Section) PXT - 10 (10" f/f Section) PXT - 20 (20" f/f Section) PEXT - 1 (12" f/m Section) PEXT - 2 (24" f/m Section) PEXT - 3 (36" f/m Section) PEXT - 4 (48" f/m Section) PEXT - 6 (72" f/m Section)
(5/10 Vent)	RXT - 10 (10" f/f Section) RXT - 20 (20" f/f Section) REXT - 1 (12" f/m Section) REXT - 2 (24" f/m Section) REXT - 3 (36" f/m Section) REXT - 4 (48" f/m Section) REXT - 6 (72" f/m Section)
E - Elbows (5/8 Vent)	PEL-90MM (m/m 90° Elbow) PEL-90FF (f/f 90° Elbow) PEL-90FM (f/m 90° Elbow) PEL-45FM (f/m 45° Elbow)
(5/10 Vent)	REL-90MM (m/m 90° Elbow) REL-90FF (f/f 90° Elbow) REL-90FM (f/m 90° Elbow) REL-45FM (f/m 45° Elbow)
F - Wall Penetration Kit	RFVK01F (5/10 venting only) PRVK01F (5/8 venting only) PRVK01 (5/8 venting only)
G - Support Ring & Plate	PSPXT-8 (5/8 venting) RSPXT-10 (5/10 venting)
H - Firestop	FS-8 FS-10
I - Roof Flashing	PRF-7 (1/12 - 7/12 pt.) PRF-12 (7/12 - 12/12 pt.)
J - Heat Shield	RHS101 (5"/8") RHS102 (5"/10") RHS104 (5"/10")
K - Heat Guard	MTKOG
L - Reducing Collar	RVA108 (5/10 to 5/8)

Connection and installation of the vent components should adhere to the following guidelines:

- Use any combination of rigid and flex pipe as required and in any orientation (Male connectors can face in any direction).
- Flex sections may be stretched up to 150% of their total length (e.g. a 24" section may be stretched to 36").
- Connect all vent sections using a minimum of three sheet metal screws on the outer pipe flue.
- Ensure the pipe ends male to female slide in a minimum of 1 1/2" of overlap.
- Ensure all horizontal runs are supported with a minimum of 3 supports per 10' of venting.
- When hanging/supporting venting, ensure that 1" clearance is maintained on sides and bottom of vent runs and 2" above horizontal vent runs to any combustible material.
- Rigid pipe may be cut less than half way from the **FEMALE END ONLY**.
- Ensure when cutting sections of rigid pipe to maintain integrity of internal supports.
- Flex pipe cannot be cut
- Place the springs, supplied with the pipe kit (flex only), between the outer and inner pipes to keep the pipes separate and avoid any possible hot spots.
- Montigo recommends the use of a flex section for the first section of venting connected directly to the fireplace, offering greater flexibility of installation and absorption of movement.
- Firestops must be installed as required by national & local codes.
- Montigo recommends that all exterior corners and joints be sealed with exterior caulking. However, we encourage you to consult your Building Envelope Engineer or Waterproofing Consultant for further recommendations.

IMPORTANT:

Please refer to your Building Envelope Engineer or Waterproofing Consultant for a review of ALL penetrations through exterior walls or the roof.

Section 3-3-2.2: Alternate Venting Components 5"/8"

Installation

The following components are approved for use with Montigo products. Please contact your local Montigo dealer for further information.

Component	Montigo P/N	DuraVent P/N	ICC P/N	MetalFab P/N	Selkirk P/N	Flexmaster P/N
NOTES		DuraVent adaptor is designed for collared vent components, DuraVent raw flex is true 5/8				
Termination	PTO4 (3" Length) PTO4F (3" Length) PVTK1SS (5/8 Vent)	58DVA-HC (Horiz. 5/8 vent) 58DVA-VCH (Vert.5/8 Vent)				
Rigid Sections (5/8 Vent)	PEXT - 1 (12" f/m) PEXT - 2 (24" f/m) PEXT - 3 (36" f/m) PEXT - 4 (48" f/m) PEXT - 6 (72" f/m)	58DVA-06 (6") 58DVA-09 (9") 58DVA-12 (12") 58DVA-18 (18") 58DVA-24 (24") 58DVA-36 (36") 58DVA-48 (48") 58DVA-60 (60")	5DL6 (6") 5DL9 (9") 5DL1 (12") 5DL2 (24") 5DL3 (36") 5DL4 (48")	5D6 (6") 5D12 (12") 5D18 (18") 5D24 (24") 5D36 (36") 5D48 (48")	5DT-06 5DT-09 5DT-12 5DT-18 5DT-24 5DT-36 5DT-48	5DVKIT58X01 5DVKIT58X01.5 5DVKIT58X02 5DVKIT58X03 5DVKIT58X04 5DVKIT58X06
Flex Sections (with collar)	PFL1 (12" flex pipe) PFL18 (18" flex pipe) PFL2 (24" flex pipe) PFL3 (36" flex pipe) PFL4 (48" flex pipe) PFL6 (72" flex pipe)	58DVA-36FF (36" F/F Section) 58DVA-60FF (60" F/F Section) 58DVA-120FF (120" F/F Section)				
Flex Sections (Raw, no collar) DuraVent adaptor 58DVA-AD-M1 not required when using raw flex		58DVA-36FO (36" Section) 58DVA-60FO (60" Section) 58DVA-120FO (120" Section)				4DVKIT58X01 4DVKIT58X01.5 4DVKIT58X02 4DVKIT58X03 4DVKIT58X04 4DVKIT58X06
Rigid Pipe Extension	PXT12 (12" f/f) PXT20 (20" f/f)	58DVA-08A (12") 58DVA-16A (20")	5DLT (12") 5DLS1 (12") 5DLT2 (20") 5DSL2 (20")	5DAL (3" to 10")	5DT-AJ12 (12")	
Rigid Telescopic Pipe		58DVA-17TA 58DVA-24TA	5DLA30			
Elbows (5/8 Vent)	PEL-90MM (m/m 90°) PEL-90FF (f/f 90°) PEL-90FM (f/m 90°) PEL-45FM (f/m 45°)	58DVA-E30 (30°) 58DVA-E45 (45°) 58DVA-E60 (60°) 58DVA-E90 (90°)	5DE45 (45°) 5DE90 (90°)	5D45L (45°) 5D90L (90°)	5DT-EL45 (45°) 5DT-EL90 (90°)	
Support Ring & Plate	PSPXT-8	58DVA-DC	5CS		5DT-CS	
Firestop	FS-8	58DVA-WFS 58DVA-FS	5CS	5DFS	5DT-FS	
Roof Flashing	PRF-7 (1/12 - 7/12 pt.) PRF-12 (7/12 - 12/12 pt.)	58DVA-FF (flat roof) 58DVA-F6 (0/12 - 6/12 pt.) 58DVA-F12 (7/12 - 12/12 pt.)		5DF (1/12 - 7/12 pt.) 5DF-12 (8/12 - 12/12 pt.)	5DT-AF6 5DT-AF12	
Metal/Tile Roof Flashing		58DVA-F6DS (0/12-6/12 pt.) 58DVA-F12DS (7/12-12/12 pt.)				
Heat Shield	RHS101	58DVA-WTU 58DVA-WT	5WT 5WTE		5DT-WT	2DVWTE58
Attic Radiation Shield		58DVA-IS	5AS 5RDS		5DT-AIS	
Vinyl Siding Heat Shield	VSS VSSSS	58DVA-VSK (Vinyl Siding Standoff)				
Wall Support		58DVA-WS	5WS	5DWS	5DTWSB	
Offset Support		58DVA-ES	5OS		5DT-OS	
Vaulted Ceiling Support		58DVA-CS	5SS	5DRS	5DT-CCS	
Storm Collar	SC8	58DVA-SC	5SC 5SQSC	5DSC	5DT-SC	
Montigo Fireplace Adapter		58DVA-AD-M1	TM-5AA6	5DNA		
Montigo Termination Adapter		58DVA-AD-M2	TM-5TA1	5DMTA		

Flexmaster as alternate venting

Flexmaster flex venting is approved on all Montigo residential fireplaces. Flexmaster Flex pipe may be used in any length as long as the respective vent graph provided in the manual is adhered to. This approval on Flexmaster Flex includes all and any prepackaged vent kits by Montigo containing Flexmaster venting. All Montigo prepackaged vent kits may be used on any Montigo residential unit fireplace. When using a Power vent you must use Montigo pipe only.

HORIZONTAL FLEX RUN REQUIREMENTS:

Follow venting graph for each model as required. Support horizontal sections every 2ft to prevent sagging, allow for a ¼" rise per foot of horizontal. Use high temperature silicone and three (3) screws at fireplace collar and termination collars. Reduce horizontal run by 36" for each 90° offset after the first one.

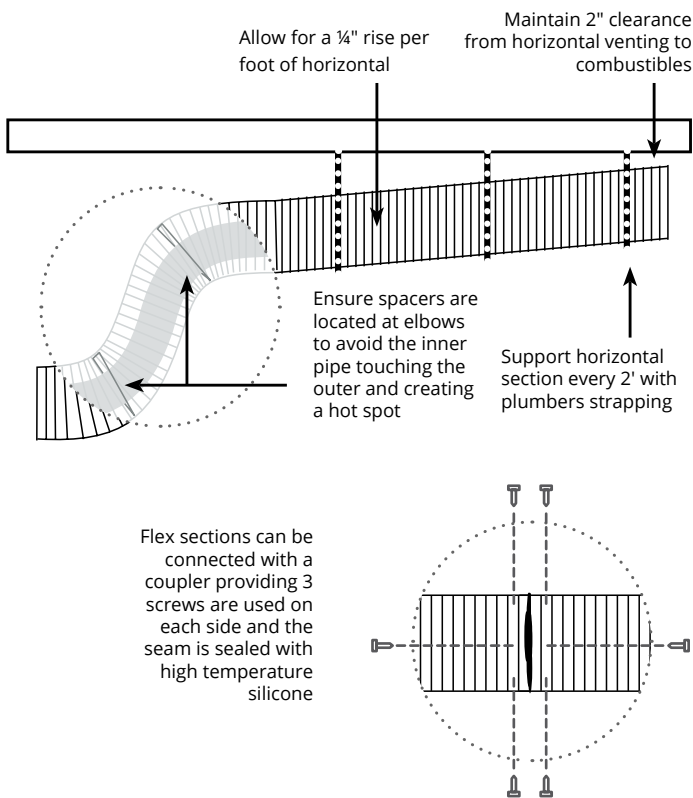

VERTICAL THROUGH THE ROOF:

Follow venting graph for each model as required. Use mil pack and three (3) screws at joints, support horizontal section every 2 ft, use one half of RHS100 as a firestop when passing through floors and ceilings, use additional firestops as necessary to keep construction debris and insulation away from contact with vent.

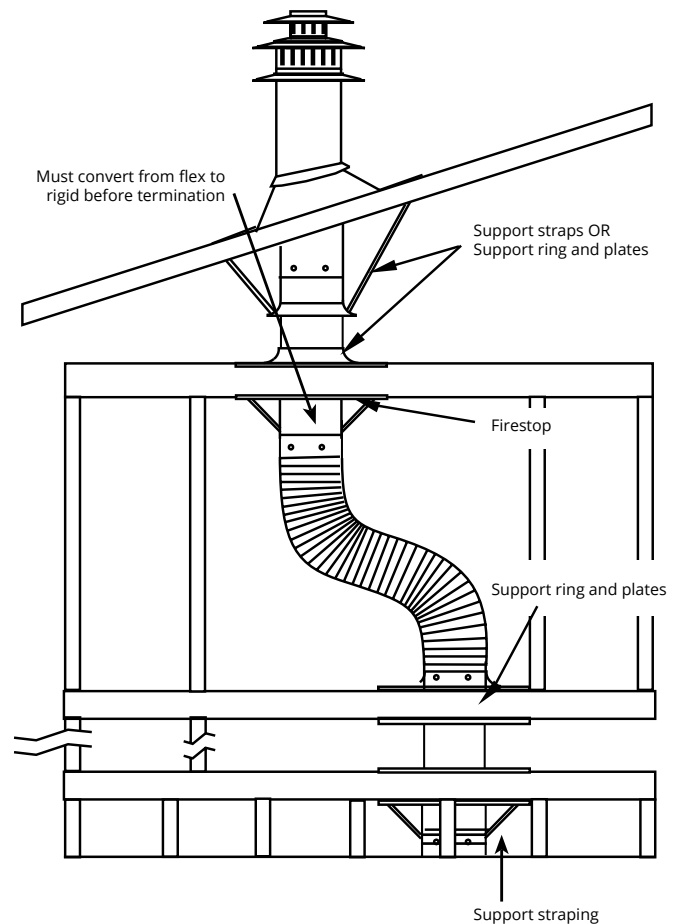

Section 3-3-3: Heat Shields 5" / 8"

Installing a Wall Mounted RHS8 heat shield

The RHS8 Heat shield CANNOT be used when the Termination is WITHIN (36" Min. horizontal and 46" Min. vertical) from the fireplace, or directly off the rear of the fireplace, as shown figure 15. The RHS101 Heat Shield (Figure 15 and 15b) MUST be used within the noted dimensions. To install the RHS8, frame an opening in combustible construction, Figure 15 below. Slide the Heat shield in place over the vent pipe which attaches to the fireplace. After the fireplace and vent pipe have been installed, clearances should match the dimensions in Figure 15.

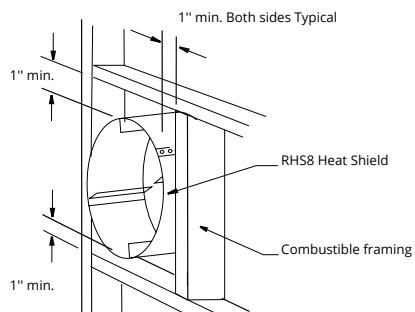

Figure 15.a RHS8 Installation. (Install by sliding over vent pipe where it passes through the combustible construction).

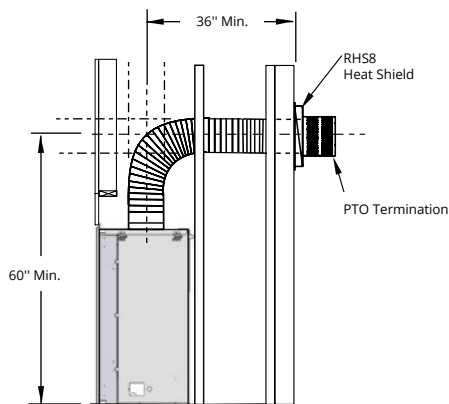

Figure 15.b RHS8 Installation. (Minimum requirements).

Installing a Wall Mounted RHS101 Heat shield

The RHS101 heat shield MUST be used where the RHS8 Termination (Figure 15.c and 15.d) CANNOT be used. Use the RHS101 where any of the dimensions are within the parameters shown, figure 15.d To install the RHS101, Slide the Inner Section over the vent pipe that will connect to the fireplace. Then fasten the vent pipe to the back of the fireplace with a minimum of three sheet metal screws.

From the outside slide the RHS101 outer section on see Figure 15.d To complete the installation fasten the heat shield outer section & termination frame to the structure Figure 15.e

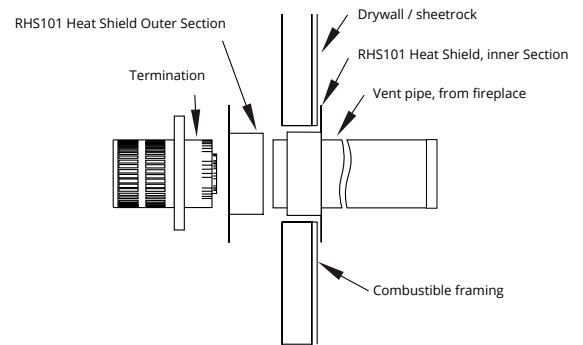

Figure 15.c RHS101 Installation. (Install by sliding Outer Section over vent pipe where it passes through the combustible construction).

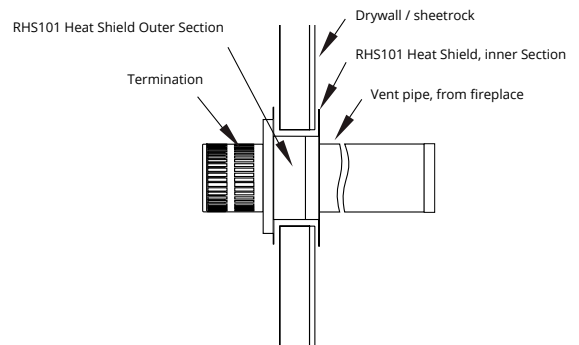

Figure 15.d Heat Shield. After sliding the outer section in place.

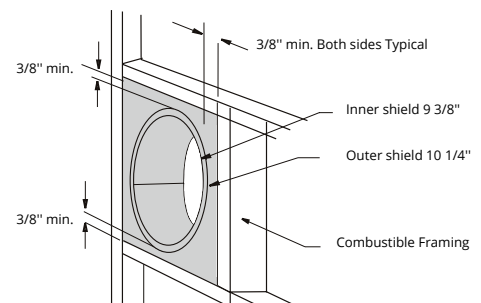

Figure 15.e RHS101 Installation

Heat Shields 5"/10" (For P52DF and PL52DF)

Installing a Wall Mounted RHS102 Heat shield

The RHS102 Heat Shield (Figure 16 and 16a) MUST be used in all cases where the venting passes through a wall. To install the RHS 102, frame an opening in combustible construction. Slide the Heat shield in place over the vent pipe which attaches to the fireplace. After the fireplace and vent pipe has been installed, clearances should match the dimensions in Figure 16.

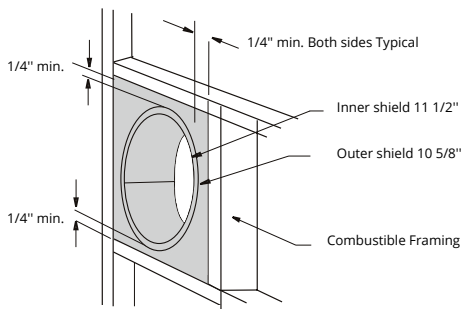

Figure 16. RHS102 Installation.

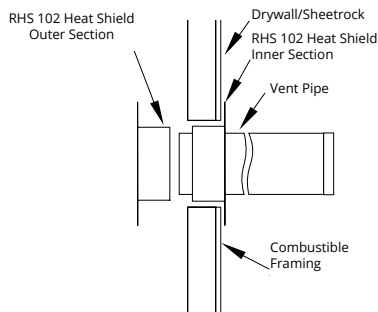

Figure 16.b RHS102 Installation.

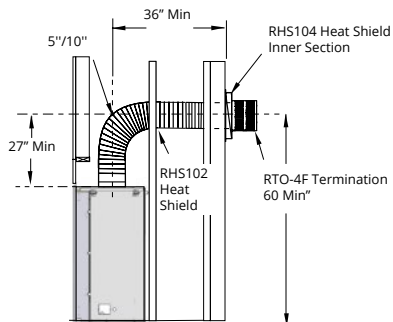

Figure 16.c RHS 102 & RHS 104 Installation. (Minimum requirements).

Installing a Wall Mounted RHS104 Heat shield

Installing a Wall Mounted RHS 104 Heat shield. The RHS104 Heat shield MUST be used in conjunction with the RTO-4F Termination (Figure 16 and 16b).

To install the RHS104, Slide the Inner Section over the vent pipe. From the outside slide the RHS104 outer section on (see Figure 16f). To complete the installation fasten the Heat Shield Outer Section & Termination frame to the structure.

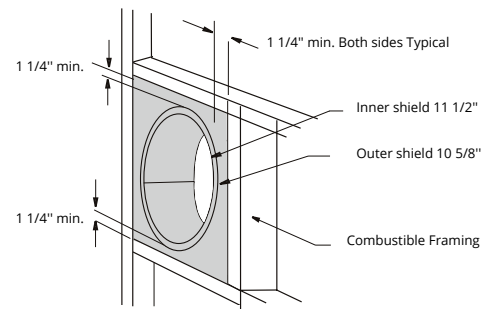

Figure 16.d RHS104 Installation

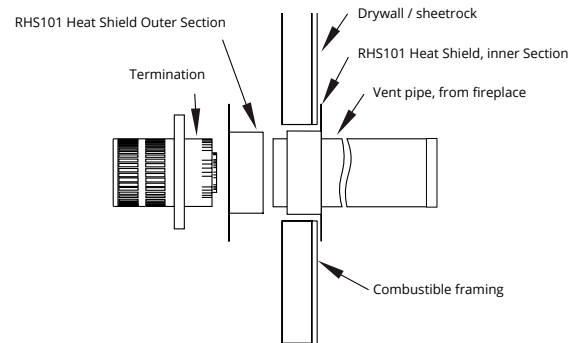

Figure 16.e RHS104 Installation.

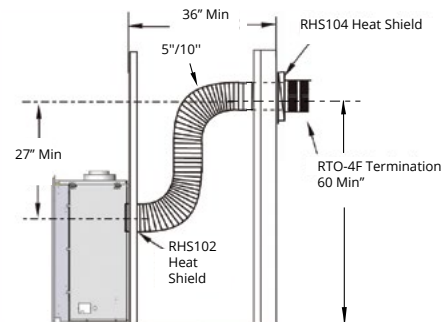

Figure 16.f RHS 102 & RHS 104 Installation. (Minimum requirements).

Section 4: Wiring

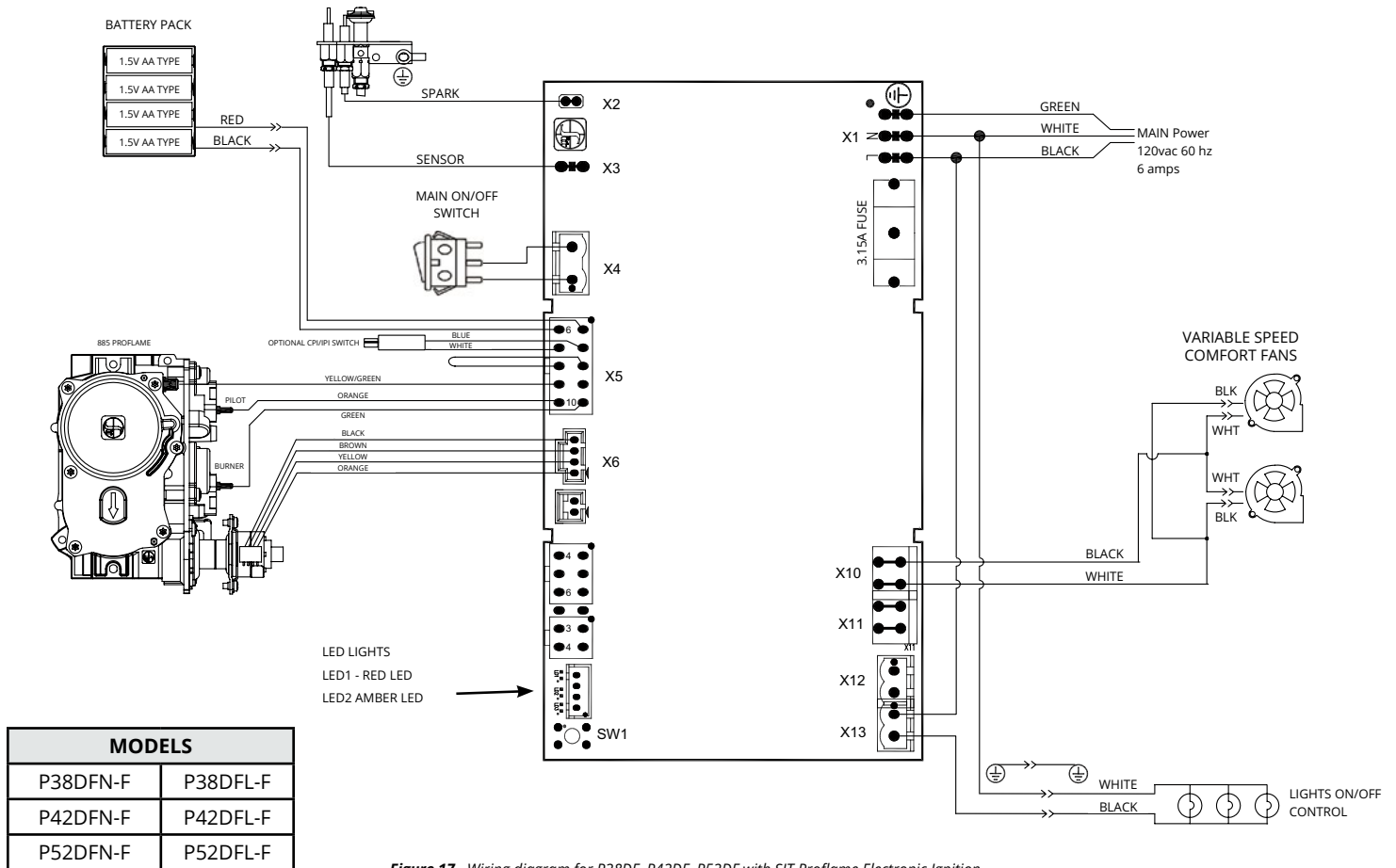

Figure 17. Wiring diagram for P38DF, P42DF, P52DF with SIT Proflame Electronic Ignition

Installation of Electrical Supply

Installations in Canada must be electrically grounded in accordance with CSA C22.1 Canadian Electrical Code Part 1 and/or Local Codes.

Installations in the USA must be grounded in accordance with local codes or, in the absence of local codes, with the National Electrical Code, ANSI/NFPA 70.

NOTE: If any of the original wire supplied with the appliance is replaced, it must be replaced with the same type, or its equivalent.

ELECTRICAL CONNECTION ACCESS PL38, P38, PL42, P42

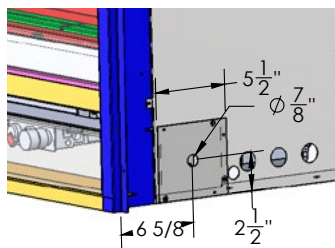

Figure 17.b Electrical connection access. (right side shown)

ELECTRICAL CONNECTION ACCESS PL52, P52

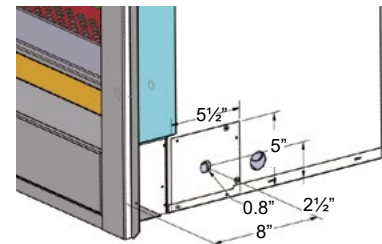

Figure 17.c Electrical connection access. (right side shown)

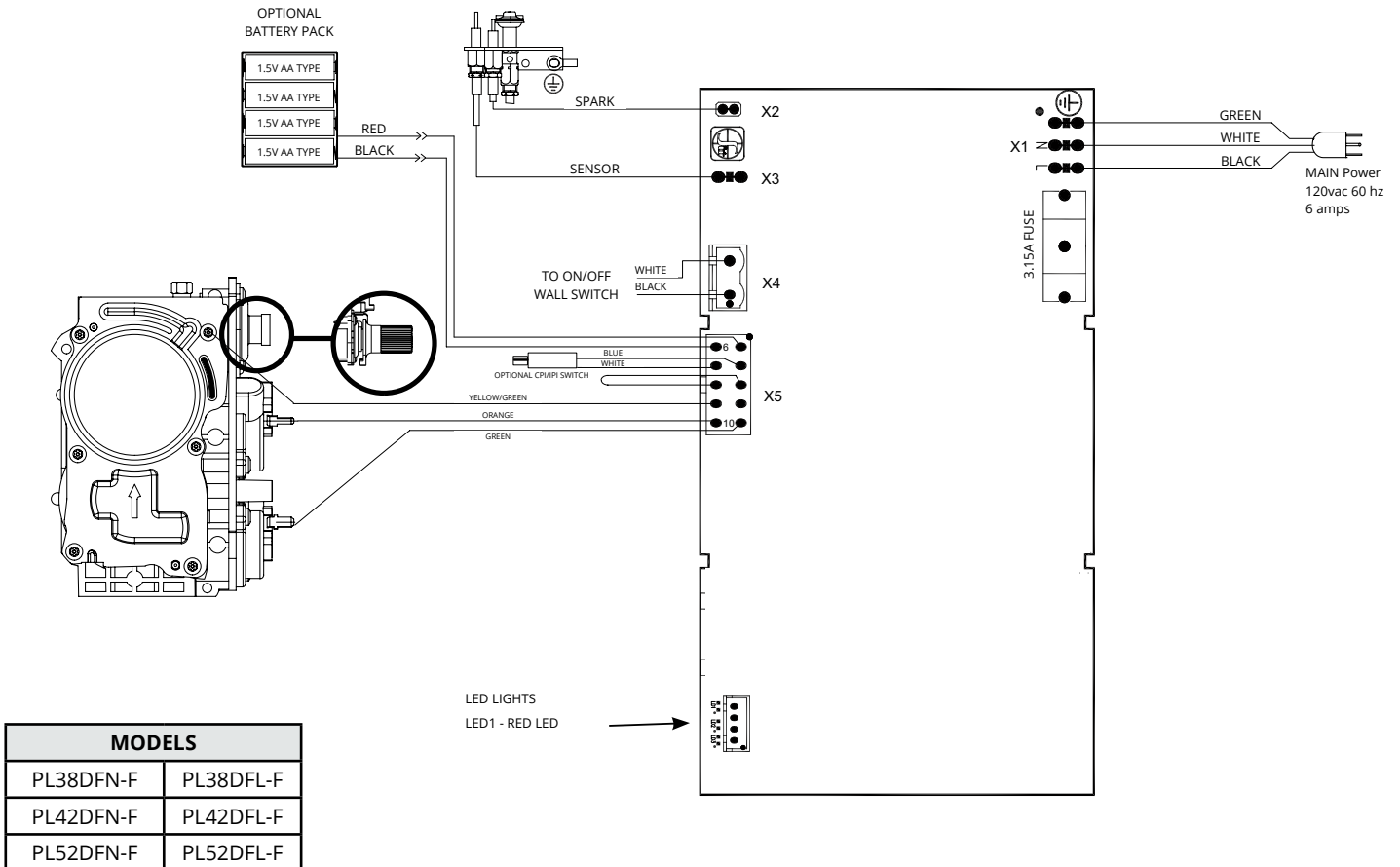

Figure 18. Wiring diagram for PL38DF, PL42DF, PL52DF with SIT Proflame BASIC Electronic Ignition

Installation of the wall switch

Montigo supplies 14' of low voltage wire to be plugged into the control board. Connect to a standard single pole ON/OFF switch to the location of your choice. You may extend these wires up to 100' in length with a wire of equal quality.

Installations in Canada must be electrically grounded in accordance with CSA C22.1 Canadian Electrical Code Part 1 and/or Local Codes.

Installations in the USA must be electrically grounded in accordance with local codes or, in the absence of local codes, with the National Electrical Code, ANSI/NFPA 70.

Optional remote control available through your Montigo Dealer.
(RX200**)

POD - Pilot on Demand

What is POD and CPI mode?

This fireplace is equipped with an "On Demand" intermittent pilot ignition system (IPI) which also includes a continuous pilot ignition (CPI) mode with an integrated seven day timer.

In IPI mode, the pilot will light before the main burner, when the appliance is turned on using a wall switch, remote or from a thermostat. Once the appliance is turned off, the main burner and pilot flame will shut down.

The continuous (CPI) mode exists to ease the startup phase in colder climates by keeping the firebox and venting warm when the main burner is not in use. The timer automatically switches off the pilot when the appliance has not been used for seven days.

When the CPI function is turned on, the pilot will remain on after the fireplace is turned off. A timer will then begin the countdown for approximately seven (7) days before shutting off the pilot if the appliance is not used. This countdown will reset anytime the burner is use.

If your appliance is equipped with a remote control device capable of selecting IPI / CPI modes, refer to remote operating instructions.

In order to start your pilot, turning the main burner on with the switch, remote or thermostat and then turning it off will reactivate the continuous pilot mode and reset the seven day timer.

A jumper is supplied with this unit that can be plugged into the wire harness connected to the controller. This jumper cable gives the Remote Control the ability to operate the POD / IPI switch and set the unit to operate in either condition. Please refer to jumper installation instructions for more information.

Remote Continuous Pilot (CPI) Selection

Requires installation of the CPI JUMPER

With the system in "off" position press the Mode Key, to index to the CPI mode icon, Pressing the Up Arrow Key will activate the Continuous Pilot Ignition mode (CPI). Pressing the Down Arrow Key will return to IPI. A single "beep" will confirm the reception of the command.

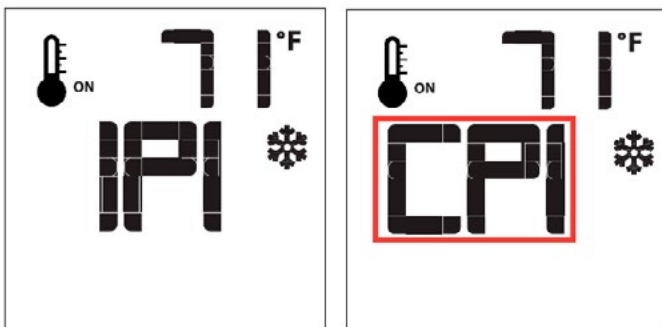

Installing the CPI Jumper Cable

- 1). Access the control box.

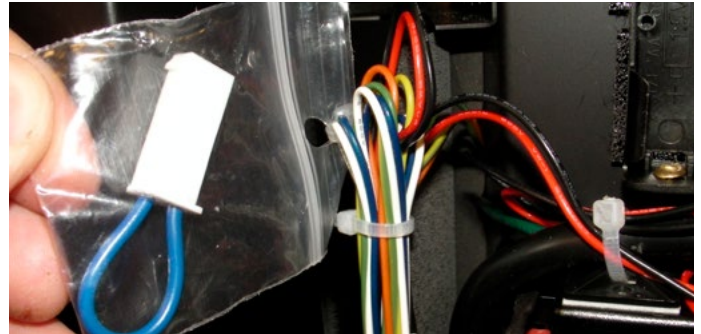

Figure 19.a Open the control box drawer

- 2). Remove the bag containing the Jumper Cable from the wire harness connected to the controller.

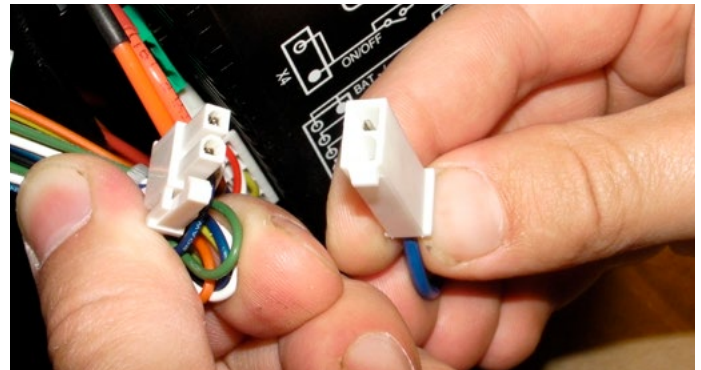

Figure 19.b Locate Jumper cable

- 3). Find the corresponding plug attached to the control wire harness and connect the CPI jumper.



Figure 19.c Connect CPI

- 4). See operation section to turn remote into CPI mode.

Section 5: Installing the gas line

Fuel Type

- Verify that your fireplace is compatible with your available gas type. (Natural Gas or Propane shown by "N" or "L" in your model number)
- If gas type is not compatible, contact your local Montigo dealer.

Gas Pressure

- Optimum appliance performance requires proper input pressures.
- Gas line sizing requirements will be determined in ANSI Z223.1/NFPA 54 National Fuel Gas Code in the USA and CAN/CGA B149.1 in Canada.

Pressure requirements (during operation):

PRESSURE REQUIREMENTS		
Gas Pressure	Natural Gas	Propane
Minimum inlet pressure	5.5in. w.c.	11in. w.c.
Manifold pressure	3.5in. w.c.	10in. w.c.

Figure 20. Pressure Requirements

- The manifold outlet pressure is set from the factory to the appropriate pressure but should be verified.
- To check pressures, control valves have a provision to remove a 1/8" N.P.T. plug to be fitted with a hose barb.
- Montigo requires a service shut off valve be located in an accessible location to isolate the gas supply.
- Only install gas shut-off valves approved for use by the state, province, or other governing body in which the fireplace is being installed.

Section 5-3: GAS CONNECTION

- See Figure 20.b or 20.c for location of gas line access.
- Flexible gas connectors must not exceed 2 feet in length, unless allowable within local regulations.
- Connect incoming gas line to the 1/2" or 3/8" gas inlet port.
- Check appliance connection, valve and valve train under normal operating pressure with a commercially available leak check solution.

DO NOT USE A FLAME OF ANY KIND TO TEST FOR LEAKS.

NOTICE

When pressure testing the fireplace, gas line, and input system follow the appropriate local codes for your area. DO NOT connect the fireplace to pressures in excess of **0.5 psig. (14" w.c.)** This will damage the gas control valve.

⚠ DANGER

After gas line is connected, each appliance connection, valve and valve train **MUST** be checked while under normal operating pressure with either a Liquid Solution, or Leak Detection Device, to locate any source of leak. Tighten any areas where bubbling appears or a leak is detected until bubbling stops completely or leak is no longer detected. **DO NOT** use a flame of any kind to test for leaks. A fire or explosion will occur, causing serious injury, property damage or death.

⚠ WARNING

An inspection of the explosion relief flappers and door **MUST** be made prior to lighting the fireplace. A faulty seal on the door gasket and/or explosion ports will result in products of combustion leaking into the living space and may result in carbon monoxide poisoning.

GAS LINE ACCESS PL38, P38, PL42, P42

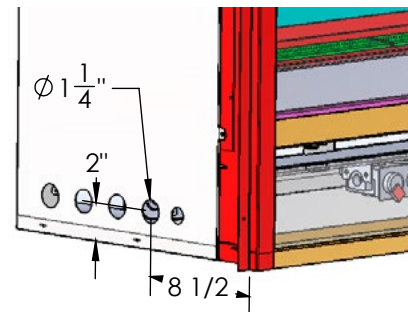

Figure 20.b Gas Inlet Supply location (left side shown)

GAS LINE ACCESS PL52, P52

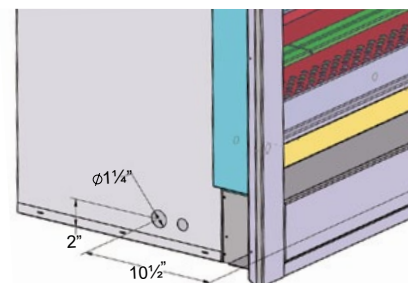

Figure 20.c Gas Inlet Supply location (left side shown)

Section 6: Finishing

Finishing Around the Fireplace

Combustible mantels and mouldings may be safely installed over the top and on the front of the fireplace provided that they do not project beyond shaded area shown in Figure 21.a - 21.c

Fireplace Facing

When sizing the finish material for your fireplace, it is important to remember the following: THE OPENING MUST NOT BE OBSTRUCTED IN ANY WAY - to do so restricts the air supply for the control compartments and heat exchanger it also prevents access for servicing controls.

The face of the fireplace may be painted to match the room decor, provided you use a heat-resistant paint. Decorative facing must not extend past the fireplace opening at all, because it will interfere with the access to retainers for removal of glass door

P38, PL38 COMBUSTIBLE MANTLES AND FACINGS

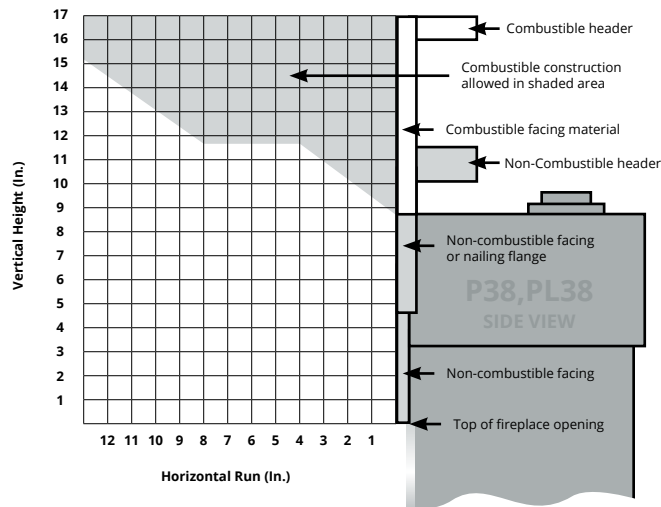

Figure 21.a Combustible mantles and facings. (Not to scale)

P42, PL42 COMBUSTIBLE MANTLES AND FACINGS

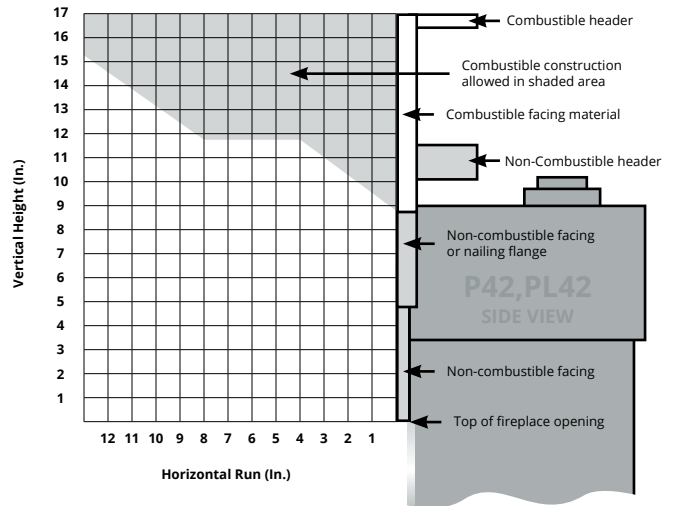

Figure 21.b Combustible mantles and facings. (Not to scale)

P52, PL52 COMBUSTIBLE MANTLES AND FACINGS

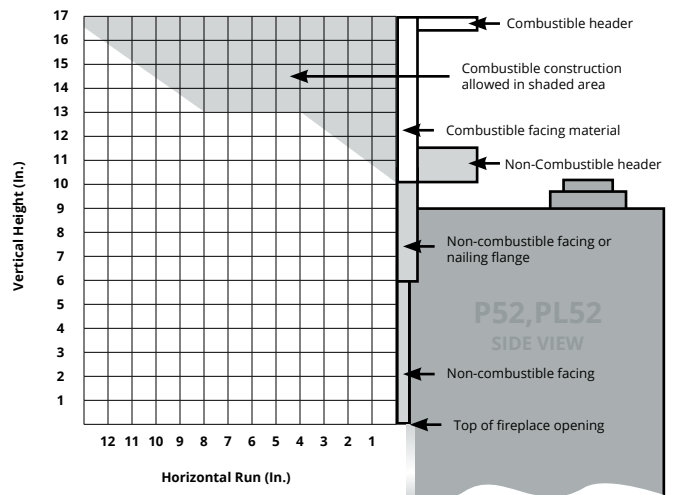

Figure 21.c Combustible mantles and facings. (Not to scale)

CAUTION

We recommend careful consideration be given to the effects of elevated mantel temperatures which may be in excess of product design, for example: candles, plastic or pictures. This can cause melting, deformation, discoloration or premature failure of T.V. radio, and other electronic components.



WARNING

Fireplaces cannot be recessed into a wall cavity.

Finishing the Fireplace

NOTE: National Canadian Gas Association mantel test requirements are for fire hazard prevention to combustible materials.

New technology, to meet consumer and government demands for the wise use of energy, has prompted us to manufacture many models of fireplaces which are hot, fuel and energy efficient.

Please be aware; temperatures over the mantel will rise above normal room temperature and walls above fireplace may be hot to touch.

NOTE: UNIT CANNOT BE RECESSED INTO A WALL

Side wall clearances are 3". Combustible surrounds may be installed with 3" clearance to the side of the fireplace as shown in Figure 21.b

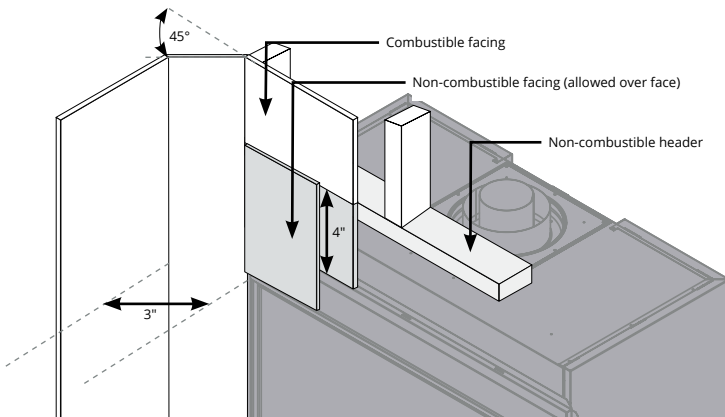

Figure 21.d Combustible facing materials.

Flush Finishing the Fireplace

A noncombustible finishing material may be installed over the face of the unit as shown below. Please be aware that the temperature of the fireplace face will be extremely hot and could be subject to cracking in seams of concrete board or tile installed directly on the face.

Please refer to the flush face finishing guide for more detailed instructions.

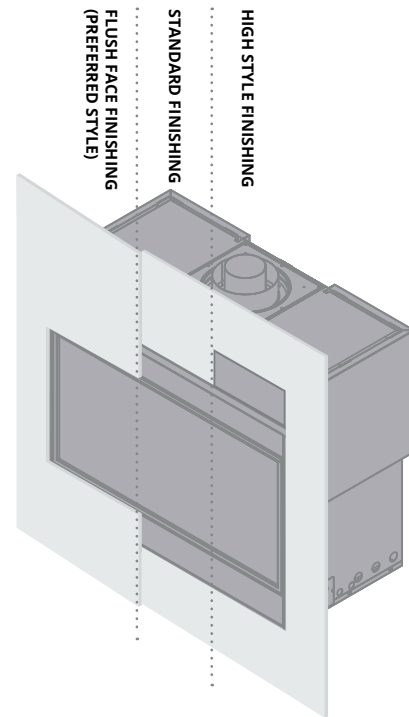

Figure 21.ddd Flush facing vs Standard vs High style

⚠ IMPORTANT

When covering the upper metal portion of the fireplace with a non-combustible material. Please note the decorative facing materials may be subject to temperatures in excess of 250°F. This should be considered when selecting facing materials.

⚠ WARNING

Do not place any materials or objects on top of the valve blind. Doing so could result in failure of door relief system or heat dissipation.

Section 7: Screen Installation and Removal

Removing the Screen

Grasp each top outer corner of the screen with your thumb and finger and pull towards yourself. When the upper Screen Studs are free, lift the screen at an angle from the lower slots from which the Screen Bottom Tabs are held. Place the screen in a safe place.

To Install Screens:

Hold the screens at an angle away from the fireplace, and locate the Screen Bottom Tabs at the lower corners of the screen. Place the screen into the Screen Tab Receptacles in the lower section of the fireplace.

Make sure the tabs and screens are lowered all the way down into the Screen Tab Receptacles on the fireplace. Then, push each Upper Screen Stud on the top corners of the screen into the Upper Screen Stud Receptacles in the fireplace.

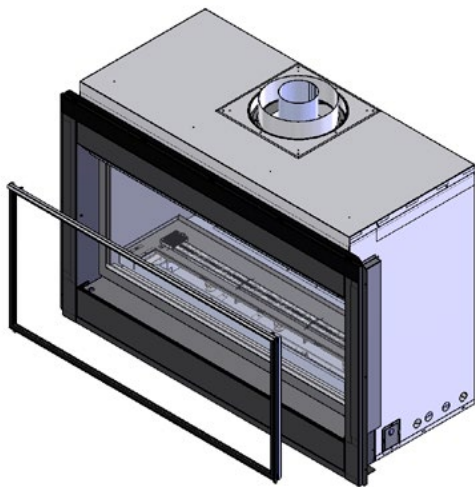

Figure 22. Lift out the Retaining Tabs and screen

CAUTION

Glass doors on gas fireplaces are extremely hot while the fireplace is on and remain hot even after the fireplace has been turned off. Safety screens are mandatory while glass is hot and can reduce the risks of severe burns. Please keep children away from the fireplace at all times.

Replacement Screens:

For replacement part order numbers, please refer to section "Replacement Parts:" on page 46.

NOTICE

Any safety screen, guard, or barrier removed for servicing an appliance, must be replaced prior to operating the appliance

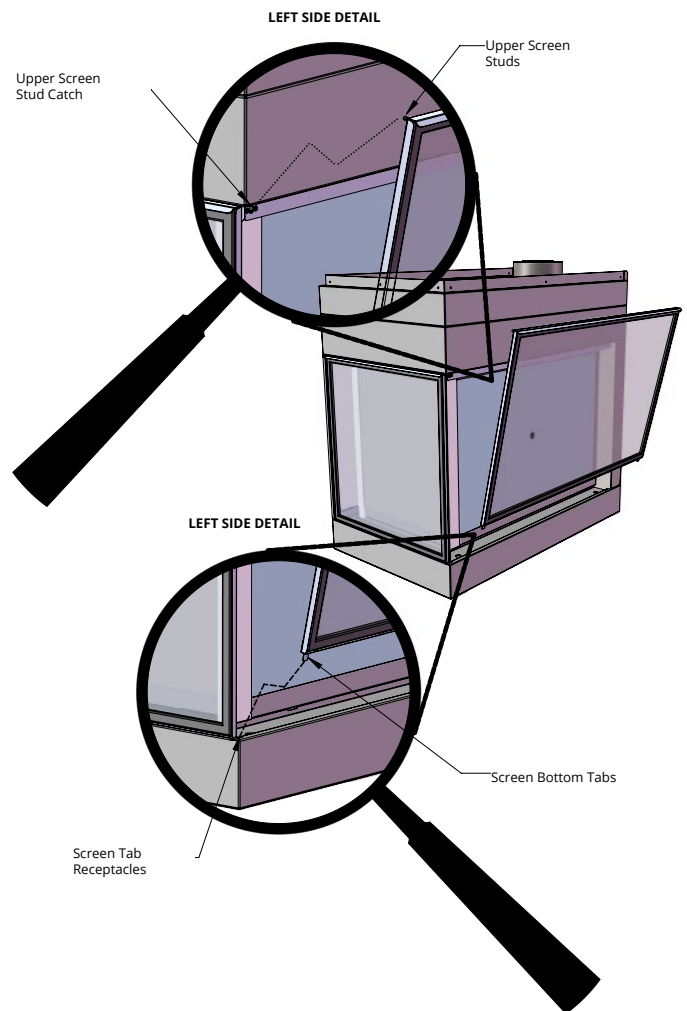

Figure 22.b Screen Installation and Removal

Section 8: Installing & Removing the Door

Removing the door:

The doors are removed in a few simple steps. Follow these below to remove the horizontal access panel, unlatch the door buckles and, remove the door. Replace in reverse order.

WARNING

When reinstalling the door(s), always make sure all door buckles are properly hooked and fully engaged.



Figure 23.a Door buckle Tool

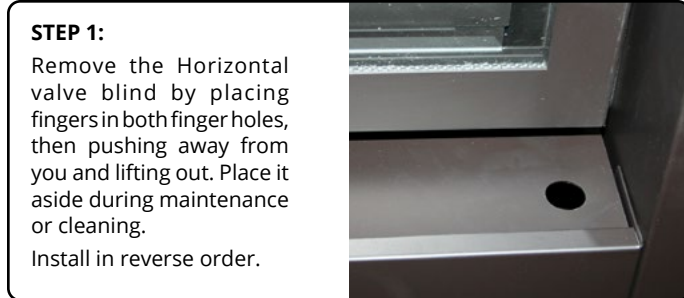

Figure 23.b Removing and installing the Horizontal Access Panel

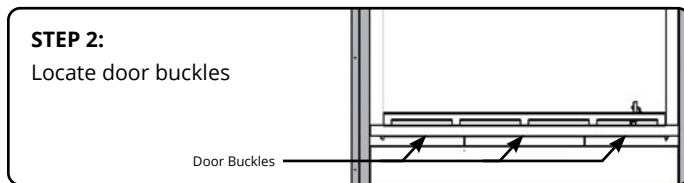

Figure 23.c Locate door buckles

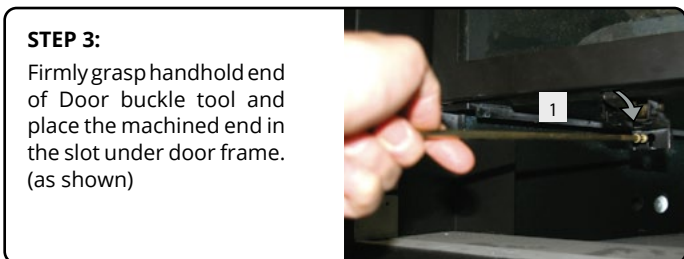

Figure 23.d Locate door latches

STEP 4:

Ensure the tool is firmly in the lower end of the slot, (as shown), Then pull toward you.

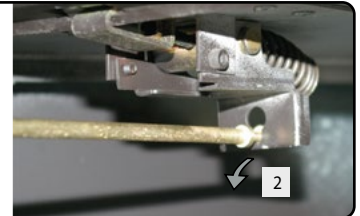

Figure 23.e Pull door latches

STEP 5:

Pull hard if necessary to release the spring tension. (Caution: The latch springs back with force, hold the tool securely).

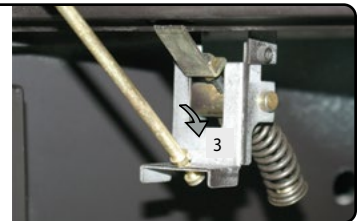

Figure 23.f Lift the latch upward

STEP 6:

Remove the tool from the latch slot. Ensure the latches are hanging freely, the hook end is released from the bottom of the door. (Repeat all 4-steps for the remaining latches).



Figure 23.g Lift the door up and out of the fireplace frame

STEP 7:

Grasp the door on either side, usually midway and lift upward, lift the door carefully up and away from the front of the fireplace. Place the door aside in a safe place while maintenance and / or cleaning is being performed.

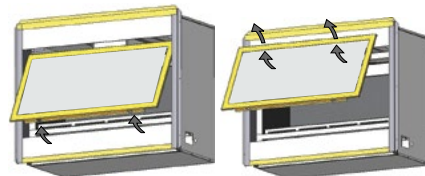

Figure 23.h Removing and installing the glass doors.

Reinstalling the door

To install the door, hook the top edge of the door frame into place. Lower the door into position and follow the previous steps shown in reverse order.

Section 9: Installing the Accessories

Installing the Uplighting Glass

(For P Units)



Figure 24.d Up-lighting glass in package.

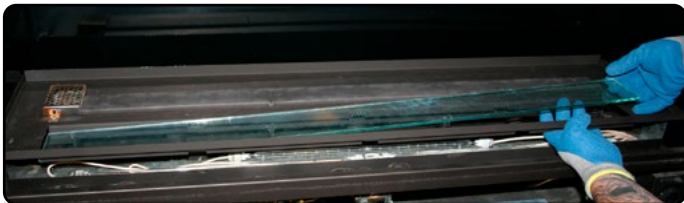

Figure 24.e Place the up-lighting glass in the burner tray.

Installing the Firestones or optional Fireglass

The unit is supplied with firestones. Optional fireglass may be purchased from the dealer. Remove the Door as shown in the previous Instruction. Once the glass door is removed place the firestones randomly across the pan and the burners as described in Figure 24 to 24.b

Note: Only cover the burner with one layer of firestones or fireglass.



Figure 24. spreading out firestones



Figure 24.b Completed firestone installation

Installing Optional Speckled Stones

[RR***SS]

Once the glass door has been removed as shown in the previous section, place the speckled stones evenly across the pan and burner. Ensure stones do not overlap too much as this will effect the flame pattern, see figure 24.c DO NOT cover the pilot with stones.



Figure 24.c Completed Speckled Stone installation

WARNING: This appliance is intended for use only with the included Montigo burners and accessories. Never install or add any additional or alternative media, rock wool or other material in this appliance. The use of additional or alternative materials may pose potential safety hazards, damage to the appliance, and void manufacturer's warranty.

Optional Log Set

The Fireplace has the option of installing a drift wood log set. Once the base media of fireglass, firestones, or speckled stones has been placed the log set can be installed. Ensure logs are securely placed and will not tip or fall.

Log Kit Installation

Log kits used to create sequence shown: 1 LGS58, 1 LGS59

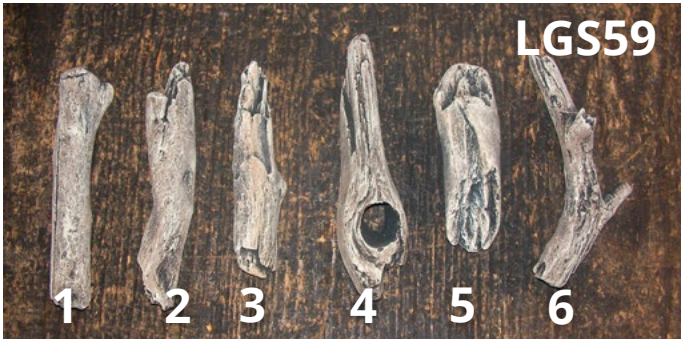

Figure 25. LGS59

STEP 1: Remove the glass door as described in the previous section.

STEP 2: Ensure selected media is installed per instruction as per Figures 24 - 24b or 24.c.

STEP 3: Unpack the logs and handle with care.



Figure 26.

STEP 4: Place Log C from LGS58 in the back right corner of the burner tray. Ensure log does not cover ports. Place Log B of LGS58 on top of log C. See Figure 26.



Figure 26.b

STEP 5: Place Log E from LGS58 on top of Log B. Place Log A from LGS58 on top of log B, see figure 26b



Figure 25.b LGS58



Figure 26.c

STEP 6: Place log 6 of LGS59 across of log A of LGS58, see figure 26c.

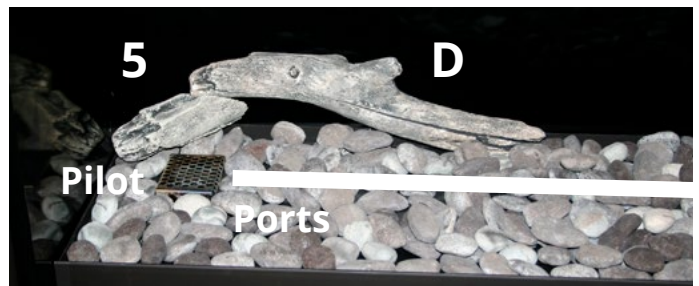

Figure 26.d

STEP 7: Place log 5 from LGS59 in the back left corner of the burner, behind the pilot. Place Log D from LGS58 on top of log 5. Use stones to help stabilize log D. See figure 26d.



Figure 26.e

STEP 8: Place log 2 from LGS59 in front of pilot. Place log 3 from LGS59 on top of log 2. See figure 26e.



Figure 26.h

STEP 11: Completed Installation



Figure 26.f

STEP 9: Place log 4 from LGS59 in front of ports just to the right of log 3 from LGS59. Place log 1 from LGS59 behind ports in the middle of the tray. See figure 26f.

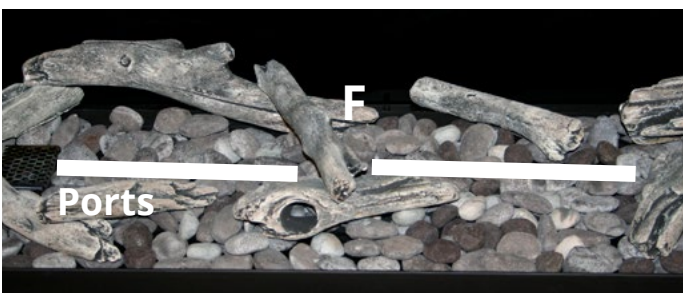

Figure 26.g

STEP 10: Place log F of LGS58 across log D from LGS58 and log 4 from LGS59, see figure 26g.



Figure 26.i

STEP 12: Watch for sooting for 30 minutes. If sooting is present, adjust media and/or logs to eliminate.

FOR YOUR SAFETY - READ BEFORE LIGHTING:

DANGER

**HOT GLASS WILL CAUSE BURNS.
DO NOT TOUCH GLASS UNTIL COOLED.**

NEVER ALLOW CHILDREN TO TOUCH GLASS.

A barrier designed to reduce the risk of burns from the hot viewing glass is provided with this appliance and must be installed for the protection of children and other at-risk individuals.

WARNING: If the information in these instructions is not followed exactly, a fire or explosion may result causing property damage, personal injury or death.

WARNING/ CAUTION: Hot while in operation. Do not touch. Severe burns may result. Keep children, clothing, furniture, gasoline and other liquids having flammable vapours away.

See installation and operating instructions accompanying this appliance for more information.

A. This appliance is equipped with an ignition system that lights the pilot burner automatically. **Do not attempt to light the pilot by hand.**

B. BEFORE LIGHTING smell all around the appliance area for gas. Be sure to smell next to the floor because some gas is heavier than air and will settle on the floor.

What To Do If You Smell Gas:

- Do not try to light any appliance.
- Do not touch any electrical switch; do not use any phone in your building.

- Immediately call your gas supplier from a neighbour's phone. Follow the gas supplier's instructions.

- If you cannot reach your gas supplier, call the Fire Department.

C. Use only your hand to operate gas control. Never use tools. If the control does not function, don't try to repair it, call a qualified service technician. Force or attempt to repair may result in a fire or explosion.

D. Do not use this appliance if any part has been under water. Immediately call a qualified service technician to inspect the appliance and to replace any part of the control system, and any gas control which has been under water.

LIGHTING INSTRUCTIONS:

1. **STOP!** Read the safety information above on this label.
2. Turn "ON" manual "ON/OFF" switch. (If available)
3. Turn Incoming gas shut off valve to the "ON" position.
4. Wait 5 minutes to clear out any gas. If you smell gas, **STOP!** Follow "B" in the safety information above on this label. If you don't smell gas, go to the next step.
5. Turn fireplace "ON" using wall switch or remote control.
6. If the Fireplace does not light, the System will cycle through two trials, (one minute audible clicking, thirty seconds of silence, and then another one minute of audible clicking). If the system locks out due to inadequate gas flow, refer to "Troubleshooting" in instruction guide.
7. After completion of the information in the Troubleshooting section, Repeat step 5.
8. If the system will not function correctly, follow the instructions "To Turn Off Gas To Appliance" and call your service technician or gas supplier.

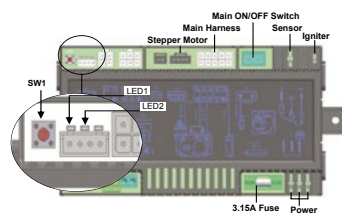

SW1 = Programming Button
 LED1 = Red Diagnostic Light
 LED2 = Amber Programming Remote Control Light
 Typical Control Module shown

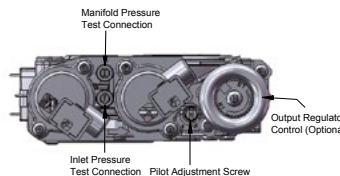

Gas Valve

TO TURN OFF GAS TO APPLIANCE:

1. Turn off fireplace using wall switch or remote control.
2. Turn the incoming gas shut off valve to "Off".

P/N LB176-060614

Remote Operation (Optional for PL Units)

The Proflame 2 System consists of the following elements:

1. Pilot Assembly
2. Proflame Gas Valve.
3. Proflame 2 Control Module
4. Wiring Harness
5. Variable Speed fans (If applicable)
7. Proflame 2 remote control
8. Battery Pack
- 9 Manual override switch

NOTE: Can not be used with home automation systems.

The Proflame 2 Transmitter controls the following fireplace functions

(all functions may not be available if used on a PL unit):

1. Main Burner On/Off
2. Main Burner flame modulation (6 levels).
3. Choice of standing or intermittent pilot (CPI/IPI).
4. Thermostat and Smart thermostat functions.
6. Fan speed modulation (6 levels).

The Proflame 2 Transmitter uses a streamlined design with a simple button layout and informative LCD display. A Mode Key is provided to index between the features and a Thermostat Key is used to turn On/Off or index through Thermostat functions, see Figure 27. Additionally, a Key Lock feature is provided.



Figure 27. Proflame 2 Remote

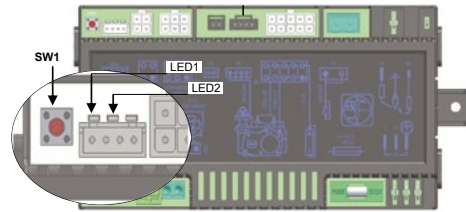

SW1 = Programming Button

LED1 = Red Diagnostic Light

LED2 = Amber Programming Remote Control Light

Figure 27.b Proflame 2 Control Module

⚠ WARNING

Do not expose remote control to temperatures below 0°C (32°F) or above 50°C (122°F)

⚠ CAUTION

Property Damage Hazard. Excessive heat can cause property damage.
The appliance can stay lit for many hours. Turn off the appliance if it is not going to be attended for any length of time.

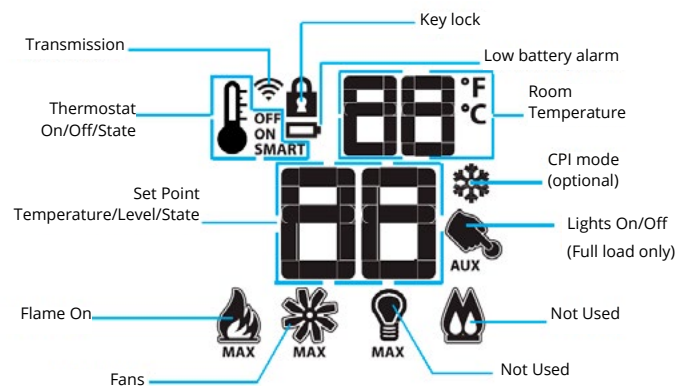

Figure 27.c Remote Control LCD Display

Initializing the System for the first time

1. Set master override switch to off position.
2. Install four (4) AA batteries into the battery holder.
3. Install three (3) AAA batteries in the back of the remote control. Note the polarity of batteries and install them as indicated by the silk screen (+/-) on the holder.
4. Connect AC Power (115 volts, 60 Hz) to fireplace.

Operating the System for the first time

Press SW1 button on the control module. The control module will beep three (3) times and an amber LED is illuminated to indicate that the IFC (control board) is ready to synchronize with a remote control within 10 sec. Push the ON button. The control module will "beep" four (4) times to indicate transmitter's command is accepted.

The System is now initialized.



WARNING

Battery operated device. Read the battery instructions before installing them into the system. Do not expose any battery, or its holder, or a device in which batteries are installed, to a working temperature greater than 54°C / 129°F



Figure 27.d Remote Control Battery Compartment

Temperature Indication Display

With the system in the "Off" position, press the Thermostat Key and the Mode Key at the same time. Look at the LCD screen on the Remote Control to verify that a C or F is visible to the right of the Room Temperature display.

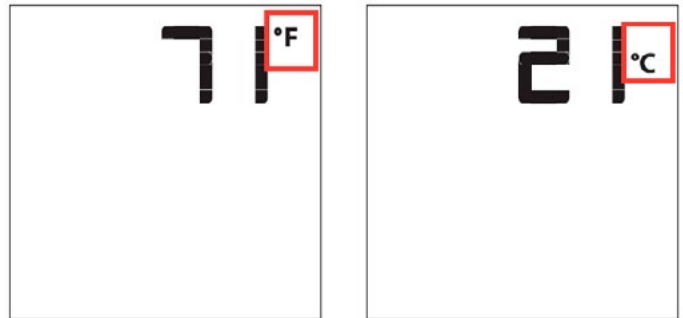

Figure 27.e Remote Control display in Fahrenheit & Celsius

Turn On the Fireplace

With the system Off, turn the master override switch to on and press the On/Off Key on the Remote Control. The Remote Control display will show some other active Icons on the screen. At the same time the Control Module will activate the fireplace. A single "beep" from the Control Module will confirm reception of the command.

Turn Off the Fireplace

With the system On, press the On/Off Key on the Remote Control. The Remote Control LCD display will only show the room temperature. At the same time the Control Module will turn off the fireplace. A single "beep" from the Receiver confirms reception of the command.



Figure 27.f Remote Control Display

Remote-Flame Control

When you turn on the fireplace it starts on high. The proflame 2 has six (6) flame levels. Each time you press the Down Arrow Key once the flame height will reduce by one step.

You can continue this until the main burner flame turns off. You can still operate the accent lights and fans in this mode.

If the main burner flame is off and you press the up arrow key once, the flame will automatically go to high.

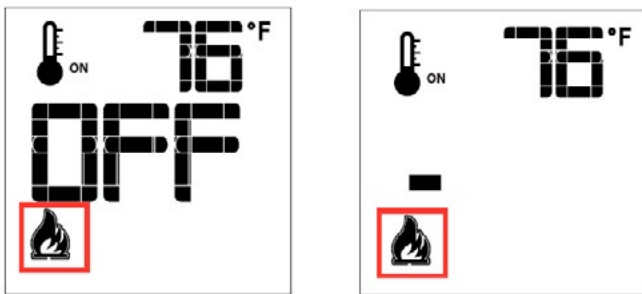

Figure 27.g Flame Off and Flame Level 1.

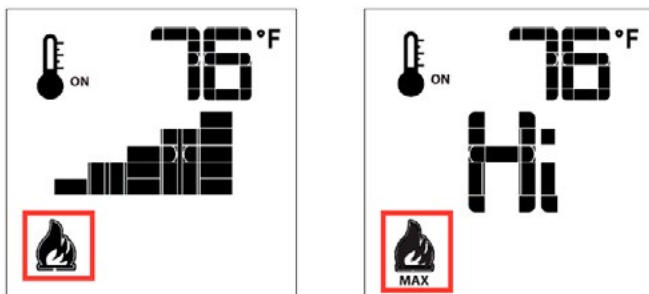

Figure 27.h Flame Level 5 and Flame Level Maximum

Room Thermostat (Remote Control Operation)

The Remote Control can operate as a room thermostat. The thermostat can be set to a desired temperature to control the comfort level in a room. To activate the function, press the Thermostat Key, see Figure 27i. The LCD display on the remote control will change to show that the room thermostat is "On" and the set temperature is now displayed. To adjust the set temperature press the Up or Down Arrow Keys until the desired set temperature is displayed on the LCD screen of the Transmitter.

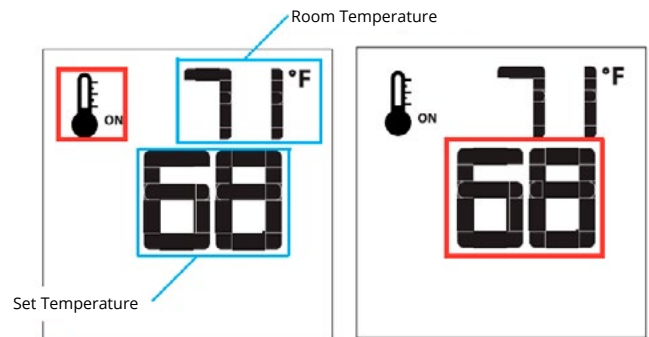

Figure 27.i Setting Room Thermostat

Smart Thermostat (Remote Control Operation)

The Smart Thermostat function adjusts the flame height in accordance to the difference between the set point temperature and the actual room temperatures. As the room temperature gets closer to the set point the Smart Function will modulate the flame down. To activate the function, press the Thermostat Key, see Figure 27.j, until the word "SMART" appears to the right of the temperature bulb graphic, see Figure 27j.

NOTE: When smart Thermostat is activated, manual flame height adjustment is disabled.

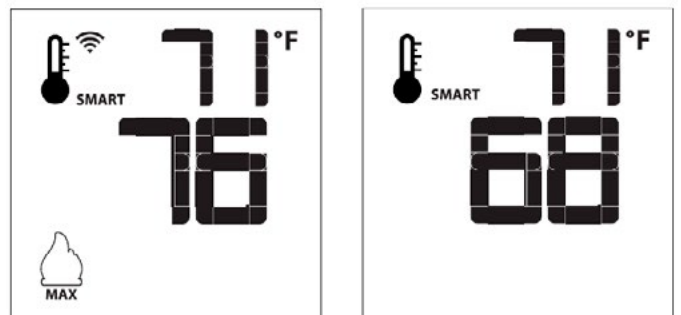

Figure 27.j Smart flame function

Disabling Thermostat

Some jurisdictions and bedroom installations require the thermostat to be disabled.

1. Partially take out one battery, see Figure 27k.
2. Insert the battery while holding down the thermostat button. The remote screen will display 'Clr' while the button is held down. See Figure 27l.
3. To enable thermostat repeat steps 1-2. The remote screen will display 'set' while the thermostat button is held down.



Figure 27.k



Figure 27.l

Fan Speed Control

The fireplace is equipped with optional hot air circulating fans. The speed of the fans can be controlled by the Proflame system. The fan speed can be adjusted through six (6) speeds. To activate this function use the Mode Key, see Figure 27, to index to the fan control icon, see Figure 27m. Use the Up/Down Arrow Keys to turn on, off, or adjust the fan speed. A single "beep" will confirm reception of the command.

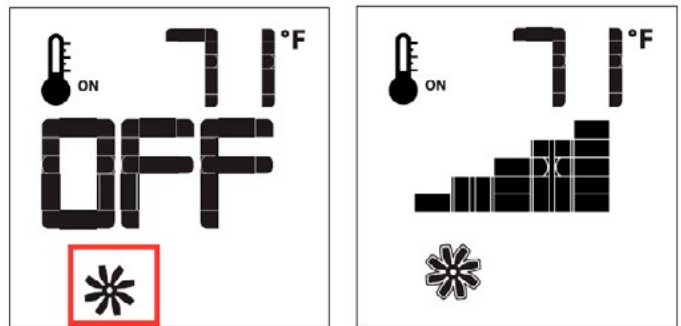

Figure 27.m Fan Speed Control

Accent Light Control (P units only)

The fireplace may be equipped with accent lights. The auxiliary function controls the Accent Lights. To activate this function use the Mode Key, see figure 27, to index to the AUX icon, see figure 27n.

Pressing the Up Arrow Key will turn the light on. Pressing the Down Arrow Key will turn the light off. A single "beep" will confirm the reception of the command.

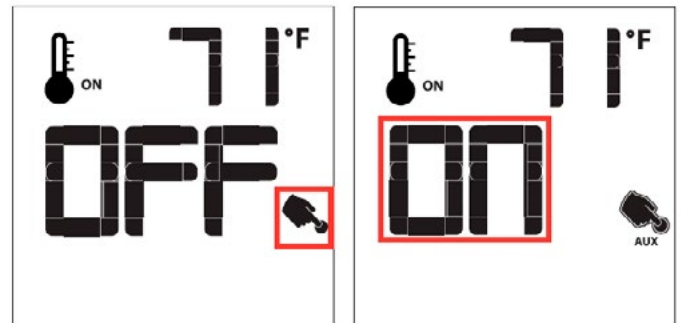

Figure 27.n Light Control

Section 10: Cleaning and Maintenance

General

- Have the fireplace and installation inspected yearly. The inspection must include, but is not limited to, the following:
 - A visual check of the entire vent system and termination, where accessible.
 - An inspection of the explosion relief flappers and the door gaskets to ensure a proper seal.
 - An inspection of the burner, vent run, and primary air openings.
 - An inspection of the gas valve, gas components, and pilot flame. For your convenience a 1/8" manifold pressure tap is supplied on the gas valve for a test gauge connection.
 - Inspection of all optional equipment; fans, thermostats, remote control lights, etc.
- For Natural Gas this appliance requires a minimum inlet pressure of 5.5" W.C. and a manifold pressure of 3.5" W.C.
- For Propane Gas this appliance requires a minimum inlet pressure of 11" W.C. and a manifold pressure of 10" W.C.
- Always keep the fireplace area clear and free of combustibile materials, as well as gasoline and other flammable vapors and liquids.
- Do not use this appliance if any part has been under water. Immediately call a qualified service technician to inspect the appliance and to replace any part of the control system and any gas control which has been under water.
- Inspection of glass doors and screen for damage and proper installation.

Cleaning

When the fireplace is first activated, there may be some smoke and a visible film may be left on the glass. This is a normal condition, and is the result of burning of protective coatings on new metal.

- Glass must be cleaned periodically to remove any film (which is a normal by-product of combustion) which may be visible. Film can easily be removed by removing the door. Handle the door carefully, and clean it with non-abrasive, non-ammonia based glass cleaners. One of the most effective products is Kel-Kem.
- During the initial firing, Silicone seals will "off gas", leaving a visual deposit of a white substance on combustion chamber walls. This can easily be removed using normal household products.
- Use a vacuum cleaner or whisk broom to keep the control compartment, burner, and firebox free from dust and lint.

Pilot Burner Adjustment.

1. Locate Pilot Adjustment Screw. (See *figure 28*)
2. Adjust pilot screw to provide properly sized flame as shown.
3. After installing or servicing, leak test with a soap solution with main burner on. Coat pipe and tubing joints, gasket etc. with soap solution. Bubbles indicate leaks. Tighten any areas where the bubbles appear until the bubbling stops completely.

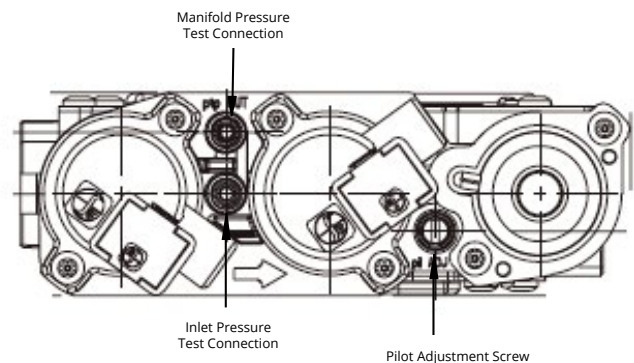

Figure 28. Pilot Adjustment on the SIT Proflame 2 gas valve.

NOTICE

Do not use ammonia or abrasive cleaners on the glass, they will permanently etch the surface. Use an approved gas fireplace cleaner such as Kel-Kem or White off.

Annual inspection list for determining safe operation of a direct vent gas fireplace

- 1) Inspect and operate the pressure relief mechanism to verify relief mechanisms are free from obstruction to operate.
- 2) Clean glass window with a suitable fireplace glass cleaner. Abrasive cleaners must not be used. Be careful not to scratch the glass when cleaning.
- 3) Inspect the operation of the flame safety system Pilot or Flame rectification device.
- 4) Inspect and ensure the lighting of the main burner occurs within 4 seconds of the main gas valve opening. Visual inspection should match that outlined in the appliance instruction manual. Inspect primary air openings for blockage.
- 5) Inspect condition of vent and vent terminal for sooting or obstruction and correct if present.
- 6) Vacuum and clean any debris in the firebox that is not supposed to be there.
- 7) Test and measure the flame failure response time of the flame safety system. It must de-energize the safety shutoff in no more than 30 seconds.
- 8) Check all accessible gas-carrying tubes, connections, pipes and other components for leaks.

Replacing Light Bulbs

The **Phenom** light bulbs can be replaced in a few simple steps. Follow the directions for removing the door on **page 35**. Once the door has successfully been removed, proceed with **figures 29 - 29c**.

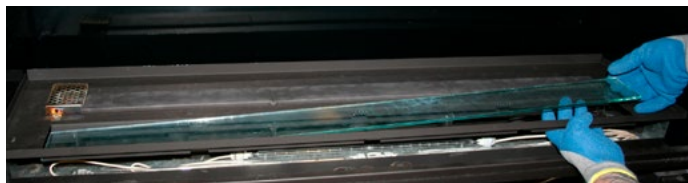

Figure 29. Remove the up-lighting glass from the burner tray.



Figure 29.b Wear gloves when handling light bulbs. To remove a light bulb, pull connecting wire away from bulb and pull light bulb up. Replace with new light bulb.

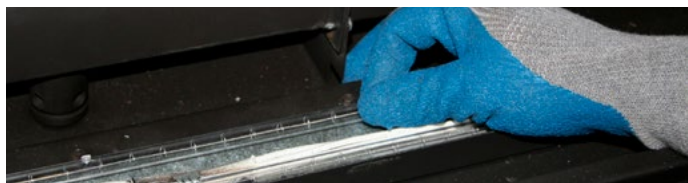

Figure 29.c Rotate newly replaced bulbs in a full circle. Place glass cover back in the burner tray.

Troubleshooting

The following is a troubleshooting chart of possible problems:

PROBLEM	SOLUTION
Pilot Igniter won't spark	<ol style="list-style-type: none"> 1. Check the MAIN ON-OFF switch (typically located below the valve cover) and turn ON 2. Ensure main power is ON or new batteries are installed in the remote control and backup battery pack (if available). 3. Check the 3.15A fuse in the control box and replace if necessary
Pilot Igniter sparking, but Pilot burner will not light	<ol style="list-style-type: none"> 1. Verify the Inlet and Manifold Gas Pressure are within acceptable limits 2. Check all connections to gas valve 3. Check connection to stepper motor (if available)
Pilot lights, but Main burner will not Light	<ol style="list-style-type: none"> 1. Check and verify all wiring connections as per the wiring diagram. 2. Verify the inlet and Manifold Pressure are within acceptable limits
Pilot lights, but Main burner will not Light and igniter continues to spark	<ol style="list-style-type: none"> 1. Check the Pilot Flame Sensor Rod and clean with steel wool or similar. 2. Check the Pilot hood and clean with steel wool if dirty. 3. Adjust pilot flame using the pilot adjustment screw if the pilot flame is too long or too short (Flame should fully engulf the sensor rod and must be stable). 4. Check and make sure the ground wire from the pilot is connected to the fireplace body.
Fans not working	<ol style="list-style-type: none"> 1. Ensure main power is ON (fireplace may be operating on back up batteries). 2. Check the 3.15A fuse in the control box and replace if necessary
One or more light bulbs are not working	Contact the local dealer for repairs or service

If your fireplace still does not operate correctly, consult your local Montigo dealer.

All service and repairs should be performed by a qualified Technician.

All spare parts, optional fans, and optional trim finishes are available from your local Montigo dealer.

Replacement Parts

Replacement Parts List - Proflame 1

Part	P38DF	P42DF	P52DF
NG Gas Valve (with stepper motor)	RGC3033	RGC3033	RGC3033
Propane Gas Valve (with stepper motor)	RGC3034	RGC3034	RGC3034
NG Pilot Assembly	RPA035	RPA035	RPA035
Propane Pilot Assembly	RPA036	RPA036	RPA036
Ignitor Probe Assembly	RGC3075	RGC3075	RGC3075
Flame sensor rod assembly	RGC3076	RGC3076	RGC3076
Pilot Tubing 18"	RPTA03	RPTA03	RPTA03
Control Module	RGC3035	RGC3035	RGC3035
Wiring Harness	RGC3041	RGC3041	RGC3041
DC Adapter	RGC3043	RGC3043	RGC3043
Tungsten Halogen Lamp (Full load only)	REC1319 (2 required)	REC1319 (2 required)	REC1319 (3 required)
Door Assembly	RDRP38	RDRP42	RDTP52
Replacement Screen	RSCP38	RSCP42	RSCP52
Designer Speckled Stones	RR250SS	RR300SS	RR350SS
Driftwood Log Set	LGSPseries	LGSPseries	LGSPseries

Replacement Parts List - SIT IPI Proflame 2

Part	P38DF	P42DF	P52DF
NG Gas Valve (with stepper motor)	RGC3033	RGC3033	RGC3033
Propane Gas Valve (with stepper motor)	RGC3034	RGC3034	RGC3034
NG Pilot Assembly	RPA035	RPA035	RPA035
Propane Pilot Assembly	RPA036	RPA036	RPA036
Ignitor Probe Assembly	RGC3075	RGC3075	RGC3075
Flame sensor rod assembly	RGC3076	RGC3076	RGC3076
Pilot Tubing	RPTA03	RPTA03	RPTA03
Door	RDRP38	RDRP42	RDTP52
Control Module Proflame 2 Full Load	RGC3095	RGC3095	RGC3095
Control Module Proflame 2 Basic	RGC3079	RGC3079	RGC3079
Proflame Transmitter	RGC3063	RGC3063	RGC3063
Tungsten Halogen Lamp (Full load only)	REC1319 (2 required)	REC1319 (2 required)	REC1319 (3 required)
Replacement Screen	RSCP38	RSCP42	RSCP52
Designer Speckled Stones	RR250SS	RR300SS	RR350SS
Driftwood Log Set	LGSPseries	LGSPseries	LGSPseries

Appendix A: Venting Terminations

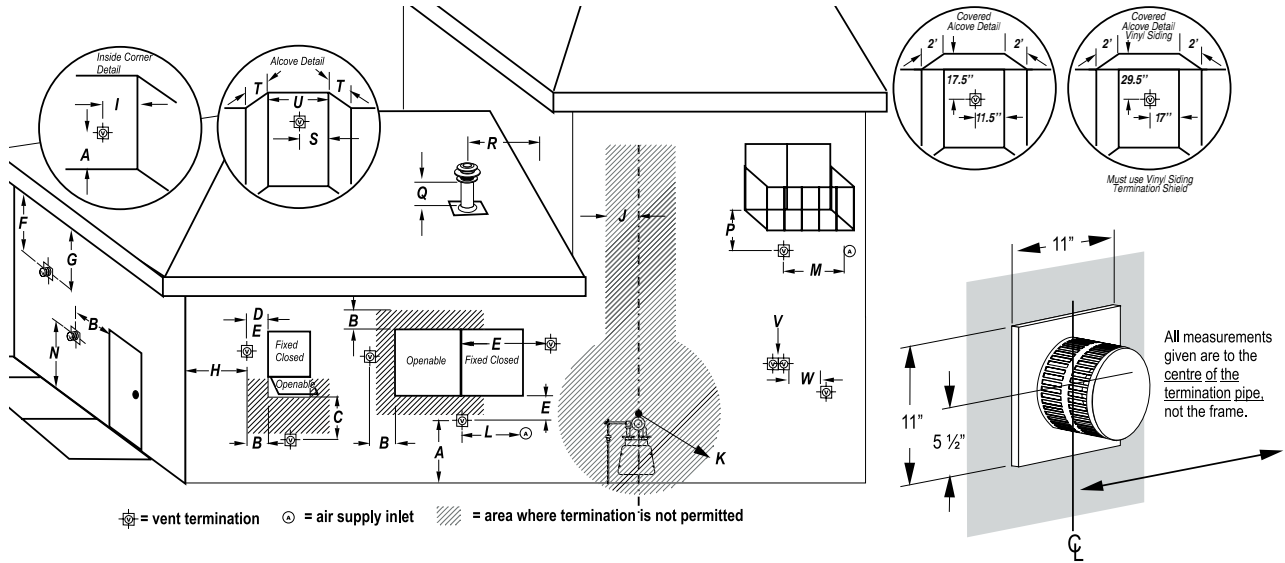

Location	Canada*	USA**
A clearance to the termination frame above grade, veranda, porch, deck, or balcony	12 inches	12 inches
B clearance to top of doors or operable windows	12 inches	12 inches
C clearance to sides or bottom of door or operable windows	12 inches	9 inches
D clearance to permanently closed window when installed with approved glass penetration termination	0	0
E clearance to permanently closed window Recommended to prevent condensation	16 inches	16 inches
F clearance to ventilated soffit located within a horizontal distance to 24 inches from centerline of termination	22 inches	22 inches
G clearance to unventilated soffit	30 inches to combustibles 16 inches to non-combustibles	30 inches to combustibles 16 inches to non-combustibles
H clearance to outside corner	9 inches	9 inches
I clearance to inside corner	12 inches	12 inches
J clearance to each side of the vertical centerline of a metre or regulatory assembly to a maximum vertical distance of 15ft	3 feet	3 feet
K clearance to service regulator vent outlet	3 feet	3 feet
L clearance to non mechanical air supply inlet to the building or combustion air inlet to other appliance for appliance <= 100,000 BTU/H (30 kW)	12 inches	12 inches
M clearance to forced air supply inlet	6 feet	3 feet above air inlet
N clearance above paved sidewalk or paved driveway located on public property	7 feet	7 feet
P clearance under veranda, porch, deck, or balcony	22 inches to combustibles 16 inches to non-combustibles	22 inches to combustibles 16 inches to non-combustibles
Q clearance above roof	2 feet	2 feet
R clearance to adjacent walls and neighboring buildings	2 feet	18 inches
S clearance from corner in recessed location	12 inches	12 inches
T Maximum depth of recessed location	4 feet	4 feet
U Maximum width for back wall of recessed location	2 feet	2 feet
V Horizontal clearance between two terminations that are level	0	0
W Horizontal clearance (centre to centre) between two terminations that are not level	18 inches	18 inches

Note 1: For N a vent shall not terminate directly above the sidewalk or paved driveway which is located between two single family dwellings and serve both dwelling.

Note 2: For P only permitted if veranda, porch, deck, or balcony is fully open on a minimum of two sides beneath the floor

Note 3: For J, K, and as specified in CGA B149 installation code. Local codes or regulations may vary.

* Based on CGA B149.1 Natural Gas and Propane installation code. Local codes may vary, please check with local regulatory agency.

** Based on ANSI Z223.1/NFPA 54 National Fuel Gas Code. Local codes may vary, please check with local regulatory agency.

Appendix B: Warranty

MONTIGO RESIDENTIAL WARRANTY PROGRAM

Canadian Heating Products Inc. and/or Montigo DelRay Corp (collectively referred to herein as "The Companies"), warrants the Montigo gas appliance (referred to herein as 'the appliance') to be free from defects in materials and workmanship at the time of manufacture. The gas appliance and related components are further subject to the terms and conditions set forth below.

This warranty covers the following Montigo product series: **Distinction, Divine & Divine Outdoor (H-Series), Illume (FID Inserts), Phenom (L/P/PL-Series), Exemplar (R/RP-Series), Mahana and DelRay**

Component	Coverage Period	Labor Coverage
Firebox, heat exchanger	15 years	1 year
Main burner	15 years	1 year
Gas control valve and related control components (pilot assembly, spark electrode flame sensors, thermopile)	1 year	1 year
Electrical components (internal blowers, ignition control module, wiring, switches, remote control systems, blower control module, accent bulbs)	1 year	1 year
Firebox media (logset, glass beads, river rocks)	1 year	1 year
Glass (thermal breakage)	1 year	1 year
Plated, painted finishes (including interior reflective glass) *	1 year	1 year
Refractory lining	1 year	1 year
Mesh/Glass safety barriers	1 year	1 year
Power vent termination	1 year	1 year
Montigo terminations*	10 years	1 year
Montigo venting (excluding termination)	15 years	1 year

* *Exterior painted surfaces exempt*

QUALIFICATIONS TO THE WARRANTY

This Warranty only covers gas appliances installed in the United States or Canada.

To receive the benefits of this warranty, the appliance must be purchased, installed and serviced annually by a dealer authorized by The Companies for the warranty to be valid.

The gas appliance must be installed by a licensed professional in accordance with The Companies' installation instructions and local building codes. The warranty on the appliance covers only components manufactured by The Companies. The use of components manufactured or supplied by other manufacturers and used in conjunction with the appliance could create serious safety hazards, may result in the denial of certification by recognized national safety agencies and could violate local building codes. Such use may untimely void this warranty. This warranty does not cover any damages occurring from the use of any components not manufactured or supplied by The Companies.

The appliance must be subjected to normal use. The appliance is designed to burn natural gas (NG) or liquefied petroleum (LP) only. Burning conventional fireplace fuels such as wood, coal or any other solid fuel will cause damage to the appliance, produce

excessive temperatures will result in a fire hazard and void all warranties. This warranty is transferable. The appliance must remain in its original place of installation to be valid.

If the components of the appliance covered by this warranty are found to be defective within the time frame stated (see The Companies investigation of claims), The Companies will, at its option, replace or repair defective components of the appliance manufactured by The Companies at no charge and will also pay for labor costs (in accordance with schedule) incurred in replacing or repairing components. If repair or replacement is not commercially practical, The Companies will, at its sole discretion, fully discharge all obligations under the warranty by refunding the verified dealer purchase price of the appliance, excluding the cost of labor unless the labor is covered by the terms of the warranty.

This warranty covers only parts and labor as provided above. In no case shall the companies be responsible for materials, components or construction, which are not manufactured or supplied by The Companies, or for the labor necessary to install, repair or remove such materials, components or construction. All replacement or repair components will be shipped F.O.B. from the nearest Company factory.

LIMITATION ON LIABILITY

It is agreed and understood that The Companies sole obligation, and purchaser's exclusive remedy under this warranty, under any other warranty, expressed or implied, or in contract, tort or otherwise, shall be limited to repair, replacement or refund as specified above. The opinion of The Companies with respect to these matters shall be final.

In no event shall The Companies be responsible for any incidental or consequential damages caused by (but not limited to) improper installation, installation by an unqualified or unauthorized installer, accident, lack of regular maintenance, user error, abuse, misuse, Acts of God, power surges, floods, natural disasters, force majeure, defects in its appliance whether such damage occurs or is discovered before or after replacement or repair, and whether or not such damage is caused by The Companies negligence. Some jurisdictions do not allow the exclusion or limitation of incidental or consequential damages, so the above limitation or exclusion may not apply to you. The duration of any implied warranty with respect to the appliance is limited to the duration of the foregoing warranty. Some jurisdictions do not allow limitations on how long an implied warranty lasts, so the above limitation or exclusion may not apply to you.

Appendix B: Warranty Continued

EXCLUSIONS TO WARRANTY

Corrosion or rust of any kind due to a lack of maintenance, inadequate combustion air or improper venting and corrosive chemicals/environments, expansion and contraction of metals or minor movements of components causing noise are not covered by this warranty.

Willful misconduct (i.e. use of the appliance with problems known to the purchaser and causing further damages), including unauthorized or self-performed 'fixing' or exploration of the appliance's internal workings will void the warranty.

Appliances on which the serial number has been altered, defaced, removed or made illegible will void the warranty.

Costs incurred for diagnosis, service work, shipping and handling of defective or replacement parts are not covered under this warranty.

The published warranties are not applicable for any equipment manufactured by The Companies that has been sold direct to the consumer via internet or auction websites. The Companies do not endorse, approve or certify any online sale of its products through auction websites, online retailers or any other method of online sales direct to consumers.

INVESTIGATION OF CLAIMS AGAINST WARRANTY

The Companies reserve the right to investigate any and all claims against this warranty and decide upon method of settlement.

The Companies are not responsible for work done without written consent of The Companies.

The Companies shall in no event be responsible for any warranty work done without first obtaining the Companies written consent.

The Companies employees and dealers have no authority to make any warranties to neither alter this warranty nor authorize any remedies in addition to or inconsistent with those stated within this warranty.

IF WARRANTY SERVICE IS NEEDED

To make a claim under this warranty, contact your installing dealer or contractor. The installing dealer is responsible for providing service and will contact the companies to initiate warranted parts replacements. In the event the installing dealer is unavailable, contact your nearest authorized Montigo dealer (www.Montigo.com) or contact Montigo direct at techsupport@montigo.com. Ensure you have your sales receipt and the model and serial number of your appliance.

DO NOT ATTEMPT TO DO ANY SERVICE WORK YOURSELF

If you cannot locate the installing dealer, or nearest dealer/distributor, you must notify The Companies in writing.

USA Offices

6955 Salashan Parkway
Ferndale WA, 98248
techsupport@montigo.com

Canadian Offices

27342 Gloucester Way
Langley, BC V4W 4A1
techsupport@montigo.com

The terms and conditions of this warranty may be altered or amended from time to time without prior notice.

WARRANTY PERIOD: Warranty coverage begins on the date of original purchase. In the case of new construction, warranty coverage begins on the date of first occupancy of the dwelling or six months after the sale of the product by an independent, authorized Company dealer/ distributor, whichever occurs earlier.

Appendix C: Amendment

(Gas Fireplace / Equipment sold in the State of Massachusetts)

5.08: Modifications to NFPA-54, Chapter 10

- (1) Revise NFPA-54 section 10.5.4.2 by adding a second exception as follows:

Existing chimneys shall be permitted to have their use continued when a gas conversion burner is installed, and shall be equipped with a manually reset device that will automatically shut off the gas to the burner in the event of a sustained back-draft.

- (2) Revise 10.8.3 by adding the following additional requirements:

- (a) For all side wall horizontally vented gas fueled equipment installed in every dwelling, building or structure used in whole or in part for residential purposes, including those owned or operated by the Commonwealth and where the side wall exhaust vent termination is less than seven (7) feet above finished grade in the area of the venting, including but not limited to decks and porches, the following requirements shall be satisfied:

1. **INSTALLATION OF CARBON MONOXIDE DETECTORS.** At the time of installation of the side wall horizontal vented gas fueled equipment, the installing plumber or gas fitter shall observe that a hard wired carbon monoxide detector with an alarm and battery back-up is installed on the floor level where the gas equipment is to be installed. In addition, the installing plumber or gas fitter shall observe that a battery operated or hard wired carbon monoxide detector with an alarm is installed on each additional level of the dwelling, building or structure served by the side wall horizontal vented gas fueled equipment. It shall be the responsibility of the property owner to secure the services of qualified licensed professionals for the installation of hard wired carbon monoxide detectors
 - a. In the event that the side wall horizontally vented gas fueled equipment is installed in a crawl space or an attic, the hard wired carbon monoxide detector with alarm and battery back-up may be installed on the next adjacent floor level.
 - b. In the event that the requirements of this subdivision can not be met at the time of completion of installation, the owner shall have a period of thirty (30) days to comply with the above requirements; provided, however, that during said thirty (30) day period, a battery operated carbon monoxide detector with an alarm shall be installed.
2. **APPROVED CARBON MONOXIDE DETECTORS.** Each carbon monoxide detector as required in accordance with the above provisions shall comply with NFPA 720 and be ANSI/UL 2042 listed and IAS certified.
3. **SIGNAGE.** A metal or plastic identification plate shall be permanently mounted to the exterior of the building at a minimum height of eight (8) feet above grade directly in line with the exhaust vent terminal for the horizontally vented gas fueled heating appliance or equipment. The sign shall read, in print size no less than one-half (1/2) inch in size, "GAS VENT DIRECTLY BELOW. KEEP CLEAR OF ALL OBSTRUCTIONS".

4. **INSPECTION.** The state or local gas inspector of the side wall horizontally vented gas fueled equipment shall not approve the installation unless, upon inspection, the inspector observes carbon monoxide detectors and signage installed in accordance with the provisions of 248 CMR 5.08(2)(a)1 through 4.

- (b) **EXEMPTIONS:** The following equipment is exempt from 248 CMR 5.08(2)(a)1 through 4:

1. The equipment listed in Chapter 10 entitled "Equipment Not Required To Be Vented" in the most current edition of NFPA 54 as adopted by the Board; and
 2. Product Approved side wall horizontally vented gas fueled equipment installed in a room or structure separate from the dwelling, building or structure used in whole or in part for residential purposes.
- (c) **MANUFACTURER REQUIREMENTS - GAS EQUIPMENT VENTING SYSTEM PROVIDED.** When the manufacturer of Product Approved side wall horizontally vented gas equipment provides a venting system design or venting system components with the equipment, the instructions provided by the manufacturer for installation of the equipment and the venting system shall include:
1. Detailed instructions for the installation of the venting system design or the venting system components; and
 2. A complete parts list for the venting system design or venting system.
- (d) **MANUFACTURER REQUIREMENTS - GAS EQUIPMENT VENTING SYSTEM NOT PROVIDED.** When the manufacturer of a Product Approved side wall horizontally vented gas fueled equipment does not provide the parts for venting the flue gases, but identifies "special venting systems", the following requirements shall be satisfied by the manufacturer:
1. The referenced "special venting system" instructions shall be included with the appliance or equipment installation instructions; and
 2. The "special venting systems" shall be Product Approved by the Board, and the instructions for that system shall include a parts list and detailed installation instructions.
- (e) A copy of all installation instructions for all Product Approved side wall horizontally vented gas fueled equipment, all venting instructions, all parts lists for venting instructions, and/or all venting design instructions shall remain with the appliance or equipment at the completion of the installation.

- (3) After NFPA-54 section 10.10.4.2 add a new section 10.10.4.3 as follows:

When more than four gas appliances are to be vented through a common gas vent or common horizontal vent manifold, a plan of the proposed vent installation shall be submitted to the Inspector and the serving gas supplier for review and approval.

Extraction from: Massachusetts Rules and Regulations

5.00: Amendments To 2002 Edition Of ANSI Z223.1-NFPA-54

Indoor fireplace in protected outdoor applications

This fireplace may be installed into outdoor locations provided they are suitably protected from direct water impingement. However, all installation clearances in the appliance manual must be observed. Framing, Clearances to Combustibles, Mantel Heights, Facing Requirements, Venting Installation, etc. Use supplied Safety Screen.

Dimension "A"	X .75	= min. overhang depth
The overhang must extend at least 75% of the roof line height (A) Height is measured from bottom of fireplace opening to the ceiling		

Example formula
Min. overhang = $A \times 0.75$
For example: if distance A is 84", the overhang must extend at least 63"

See through fireplace

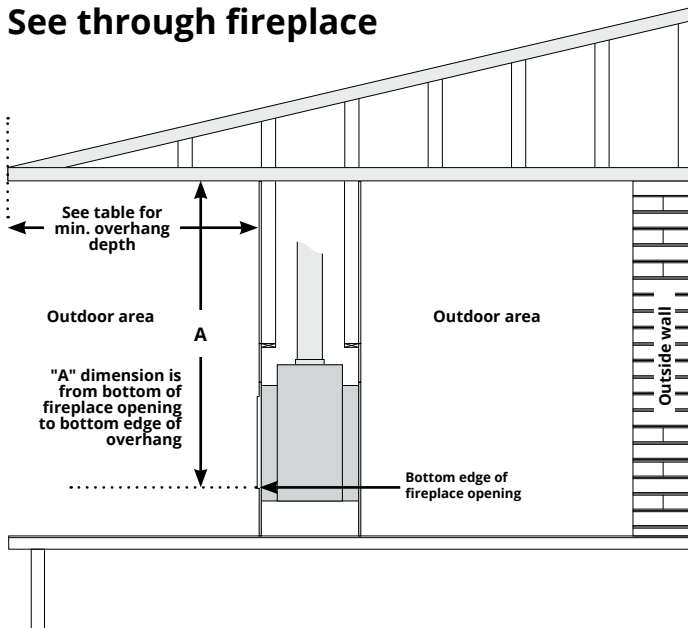

Single sided fireplace

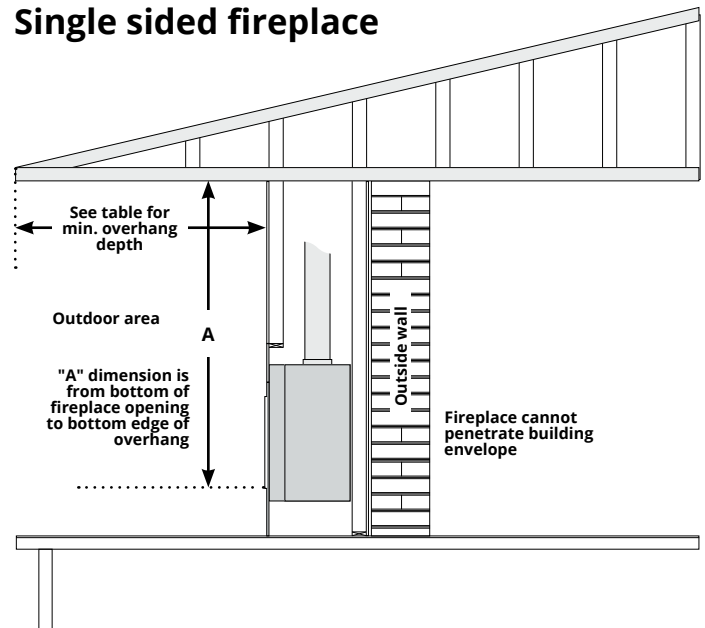

Notes

- Overhang requirements must be applied to both the front and sides of the fireplace
- Indoor see-through models cannot be installed as indoor/outdoor fireplaces, as air flows through both sides of the fireplace.
- If the fireplace will be in contact with salt water, then an outdoor fireplace is recommended
- Follow all building codes, including those addressing fireplace penetration of an exterior building envelope
- Follow all product installation instructions; including framing, clearances to combustibles, mantel heights, Facing Requirements, venting installation, etc. Use supplied safety screen.
- All wiring connections to line power shall be in accordance with outdoor requirements of; NECA NFPA 70 in the USA Canadian Electrical Code, CSA C22.1 for Canada.
- The Fireplace is not to be operated in temperatures below freezing (0°C | 32°F)

NOTICE

Units with tempered glass doors are vulnerable to rapid and/or extreme changes in temperature (thermal shock). Take care to prevent water from contacting the fireplace, especially if it is hot.

PL38DF, PL42DF, PL52DF
P38DF, P42DF, P52DF

Single Sided Gas Fireplace