



# INSTALLATION MANUAL

## SAFETY INFORMATION

### ⚠ WARNING

#### FIRE OR EXPLOSION HAZARD

Failure to follow safety warnings exactly could result in serious injury, death, or property damage.

- Do not store or use gasoline or other flammable vapors and liquids in the vicinity of this or any other appliance.

#### - WHAT TO DO IF YOU SMELL GAS:

- Do not try to light any appliance.
- Do not touch any electrical switch; do not use any phone in your building.
- Immediately call your gas supplier from a neighbour's phone. Follow the gas supplier's instructions.
- If you cannot reach your gas supplier, call the fire department.

- Installation and service must be performed by a qualified installer, service agency, or the supplier.

This appliance may be installed in an aftermarket, permanently located, manufactured home (USA only) or mobile home, where not prohibited by local codes.

This appliance is only for use with the type of gas indicated on the rating plate. This appliance is not convertible for use with other gases, unless a certified kit is used.

#### INSTALLER:

Leave this manual with the appliance

#### CONSUMER:

Retain this manual for future reference



PATENT PENDING

(Installation Option 2 illustrated)

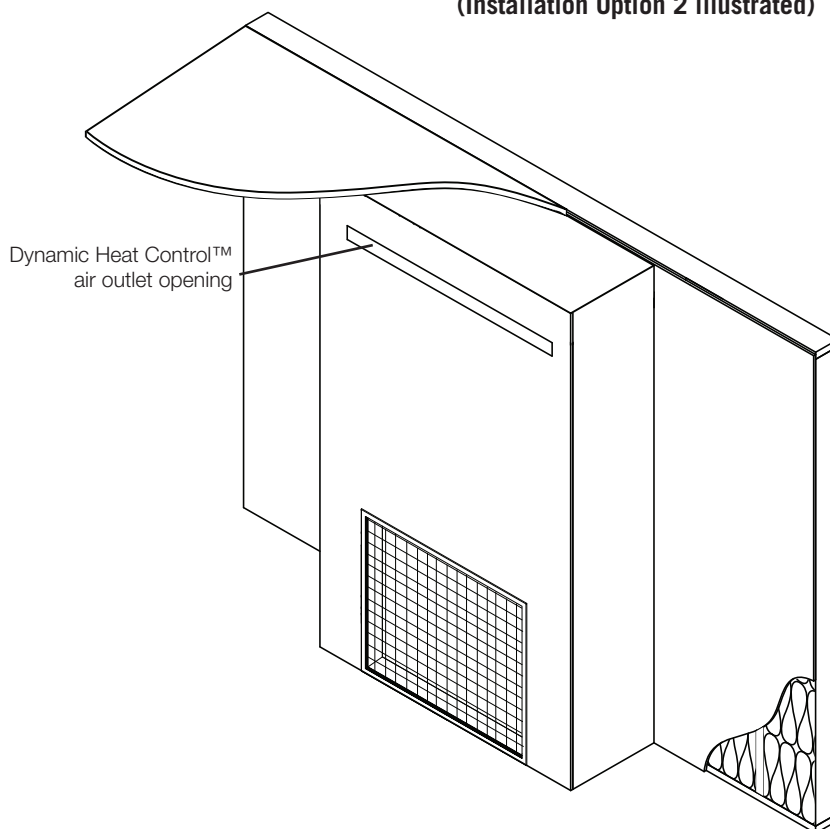

**FOR INDOOR USE ONLY**

**FOR USE WITH ELEVATION™ X  
MODELS ONLY**



Wolf Steel Ltd., 24 Napoleon Rd., Barrie, ON, L4M 0G8 Canada / 103 Miller Drive, Crittenden, Kentucky, USA, 41030  
Phone 1 (866) 820-8686 • www.napoleon.com • hearth@napoleon.com

# table of contents

<b>1.0</b>	<b>general information</b>	<b>3</b>
<b>2.0</b>	<b>installation planning</b>	<b>4</b>
2.1	installation option 1 - open enclosure (enclosure stops short of the ceiling)	5
2.2	installation option 2 - front opening	5
2.3	installation option 3 - rear opening	6
2.4	installation option 4 - open enclosure with hard combustible valance	7
2.5	installation option 5 - side openings	8
<b>3.0</b>	<b>appliance overview</b>	<b>9</b>
<b>4.0</b>	<b>Dynamic Heat Control™ installation</b>	<b>10</b>
4.1	high limit switch installation	13
<b>5.0</b>	<b>minimum framing dimensions</b>	<b>15</b>
<b>6.0</b>	<b>minimum clearance to combustible enclosures</b>	<b>16</b>
<b>7.0</b>	<b>rough framing - before appliance installation</b>	<b>17</b>
<b>8.0</b>	<b>finish framing - after appliance installation</b>	<b>18</b>
<b>9.0</b>	<b>finishing</b>	<b>20</b>
9.1	enclosure design	21
9.2	optional trim finishing	22
<b>10.0</b>	<b>minimum combustible mantel clearances</b>	<b>23</b>
<b>11.0</b>	<b>maximum protrusion</b>	<b>24</b>
<b>12.0</b>	<b>Dynamic Heat Control™ installation checklist</b>	<b>25</b>

## note:







The information throughout this manual is believed to be correct at the time of printing. Wolf Steel Ltd. reserves the right to change or modify any information within this manual at any time without notice. Changes, other than editorial, are denoted by a vertical line in the margin.

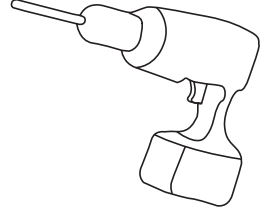

**WARNING:** This product can expose you to chemicals including chromium, which are known to the State of California to cause cancer, and chemicals including toluene, which are known to the State of California to cause birth defects or other reproductive harm. For more information, go to [www.P65Warnings.ca.gov](http://www.P65Warnings.ca.gov).

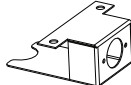
## WARNING

- **Dynamic Heat Control™ MUST** be installed during the installation of the appliance **BEFORE** appliance venting and gas are installed.
- Ensure the appliance is completely cool before starting installation.
- To avoid danger of suffocation keep the packaging bag away from babies and children. Do not use in cribs, bed, carriages, or play pens. This bag is not a toy. Knot before throwing away.

You will need:	Included in this kit
  	 Bracket  Wire Harness  High Limit Switch  Deflector  Screws



**Dynamic Heat Control™** is a system for managing the heat produced by the appliance at and around the fireplace. The purpose of the **Dynamic Heat Control™** is to move the heat away from the fireplace to allow it to circulate more effectively within the living space. By installing the **Dynamic Heat Control™** both the installer and the user gain considerable benefits, see the following;

### Installer:

- Ability to use combustible framing and finishing right up to the fireplace opening.\*
- High temperatures above the front of the fireplace opening are significantly reduced eliminating potential degrading to sensitive finish material (cracks or discoloration).
- No additional electrical, fans, ducts, or manifolds are required which keeps installation straightforward.

### User:

- Heat is circulated more consistently throughout the living space increasing comfort in front of the fireplace.
- Increased “real world” efficiency as heat is moved into the room rather than retained inside the enclosure.
- Complete flexibility in selection of finish materials.
- Ability to place a TV, sound bar or artwork above the fireplace.\*\*

The **Dynamic Heat Control™** system relies on an optimized flow of air both through the appliance and the enclosure. As such the installation of the **Dynamic Heat Control™** system requires certain technical considerations when compared to traditional fireplaces. Specifically, the **Dynamic Heat Control™** requires the **enclosure to be ventilated** and requires the installer to ensure that a minimum air outlet opening area is provided to allow heat to escape and circulate at a prescribed minimum height and position. This **must** be carefully adhered to in the planning and the installation to ensure the appliance functions safely and to minimize installation time.

**\*In most common installation configurations, some specific installations require special provisions. See “minimum clearance to combustible enclosures” section for details. Ensure to strictly adhere to instructions.**

**\*\* Always check appliance manufacturers’ recommendations to confirm suitability and any special environmental limitations. For valuable or antique items, always refer to expert preservation instructions as some items require specifically controlled temperature and/or humidity.**

## 2.0 installation planning

### ! WARNING

- Do NOT cover or place any items in the **Dynamic Heat Control™** air outlet. Failure to comply with these instructions will create a fire hazard.
- Ensure air flow within the air passage is not restricted in any way with the exception of approved venting.

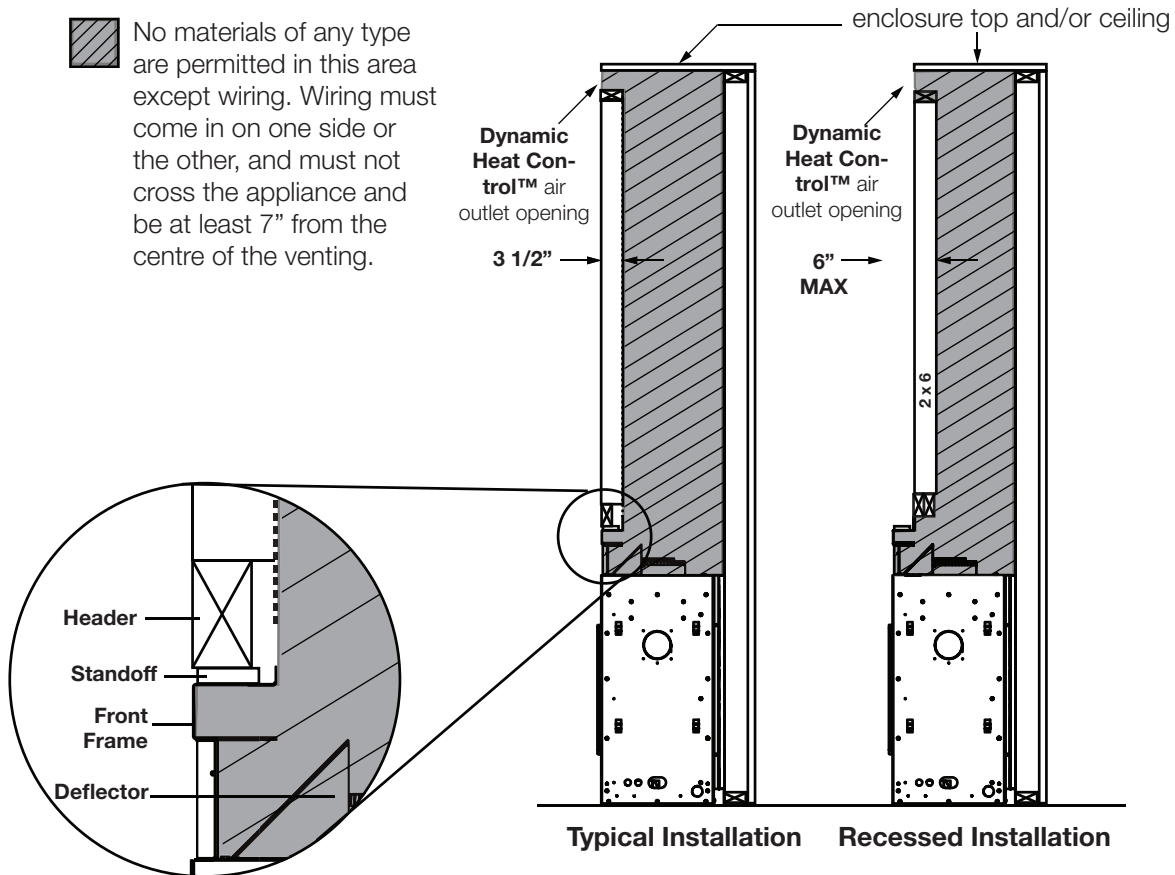

Air flow in the shaded area **must** not be restricted in any way with the exception of an approved appliance vent system. No other items are allowed in this area.

### Clearance to Fire Sprinkler

If there is a fire sprinkler system installed in close proximity to the air outlet opening of your appliance, the following installation parameters must be adhered by:

- Follow the sprinkler head manufacturer's instructions regarding proximity to heat sources.
- In the absence of specific requirements, a minimum 60" (152cm) recommended clearance, in length, between any point of the air outlet opening and fire sprinkler head.
- Verify the sprinkler head sensor is set to proper heat settings to prevent activation during appliance operation (see fire sprinkler manufacturer's instructions).
- If in doubt it is recommended to measure the temperature adjacent to the sprinkler head during installation, after the appliance has been operating continuously for at least 2 hours.
- Follow local building codes to ensure compliance.

**2.1 installation option 1 - open enclosure (enclosure stops short of the ceiling)**

**NOT suitable for Dynamic Heat Control™ Plus**

**Installation Option 1** (open enclosure) leaves a complete air outlet opening above the enclosure to provide the necessary air circulation path for the **Dynamic Heat Control™** system. This has been found to be well accepted with respect to final appearance and offer minimal distraction. It also allows for efficient circulation of air within the room. This option offers the simplest method for framing and installation. Limit the air outlet opening height to 4" to reduce the risk of items inadvertently falling into the enclosure. **The air outlet opening must extend around the entire perimeter, or the entire front face of the enclosure, where the enclosure runs from wall to wall.**

**DYNAMIC HEAT CONTROL™ AIR OUTLET OPENING IS HOT WHEN APPLIANCE IS OPERATING!**

Air outlet opening **must** be located out of reach of the user. Air outlet **must** not be restricted by furnishings or decor.

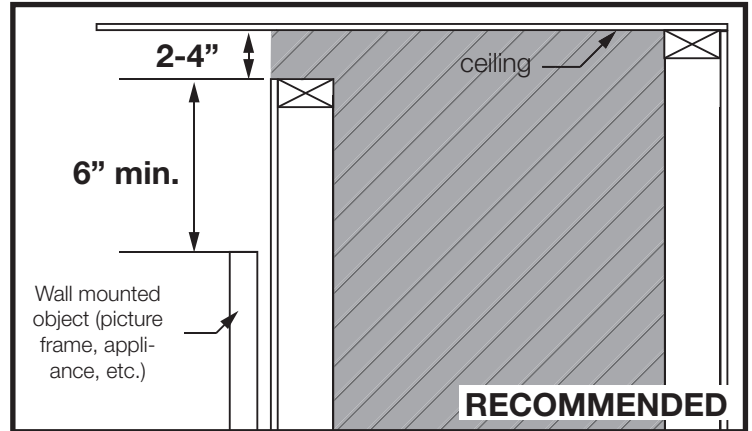
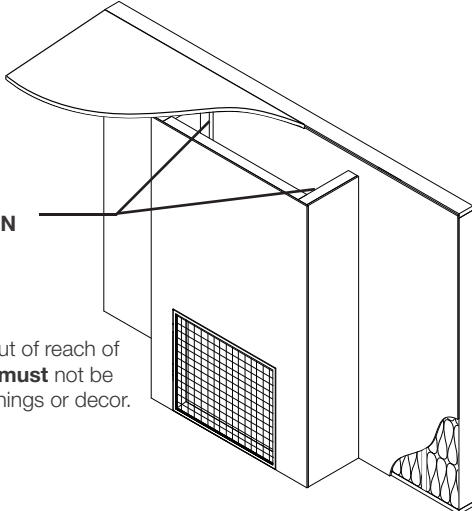

**2.2 installation option 2 - front opening**

**Suitable for Dynamic Heat Control™ Plus**

**Installation Option 2** (front opening) requires an air outlet opening to be framed no more than 1.5" below the enclosure top to avoid trapping heat in the upper areas and the air outlet opening centered on the appliance center. Minimum air outlet opening dimensions **must** be followed. **Framing the air outlet opening lower will overheat the appliance, the enclosure, and finishing material.**

**DYNAMIC HEAT CONTROL™ AIR OUTLET OPENING IS HOT WHEN APPLIANCE IS OPERATING!**

Front air outlet opening **must** be located out of reach of the user. Air outlet **must** not be restricted by furnishings or decor.

Air outlet opening is required to be centered with the appliance.

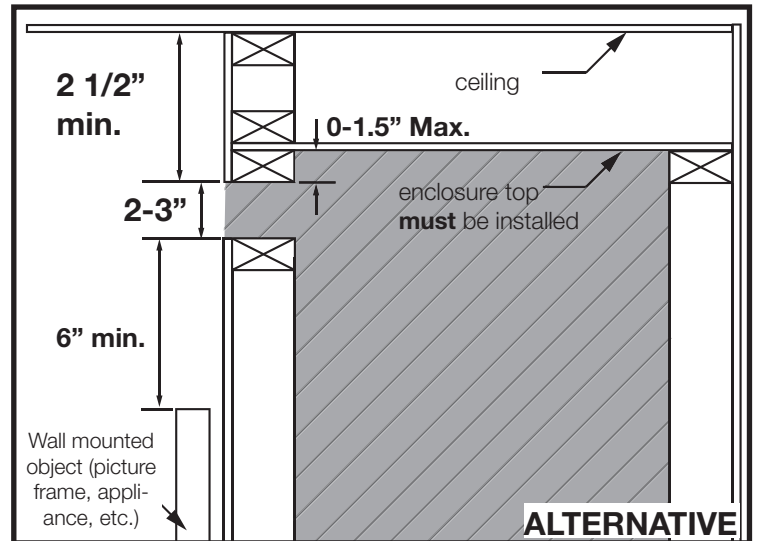
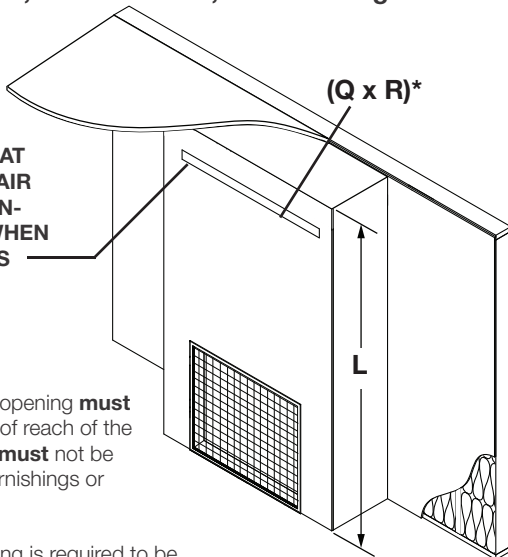

**MINIMUM AIR OUTLET OPENING DIMENSIONS**

	EX36	EX42
<b>(Q x R)*</b>	112 sq. in. minimum (Q <b>must</b> be 2-3")	
<b>L</b>	72"	

\* Grills, grates, louvers, or other covers are only permitted if the free area is equal to or greater than the required minimum opening size listed above.

# installation planning

## 2.3 installation option 3 - rear opening

### Suitable for Dynamic Heat Control™ Plus

**Installation Option 3** (rear opening) requires an air outlet opening to be framed no more than 1.5" below the enclosure top to avoid trapping heat in the upper areas and centered on the appliance center. Minimum air outlet opening dimension **must** be followed. The opening is required. **Framing the rear opening lower will overheat the appliance, the enclosure, and finishing material.**

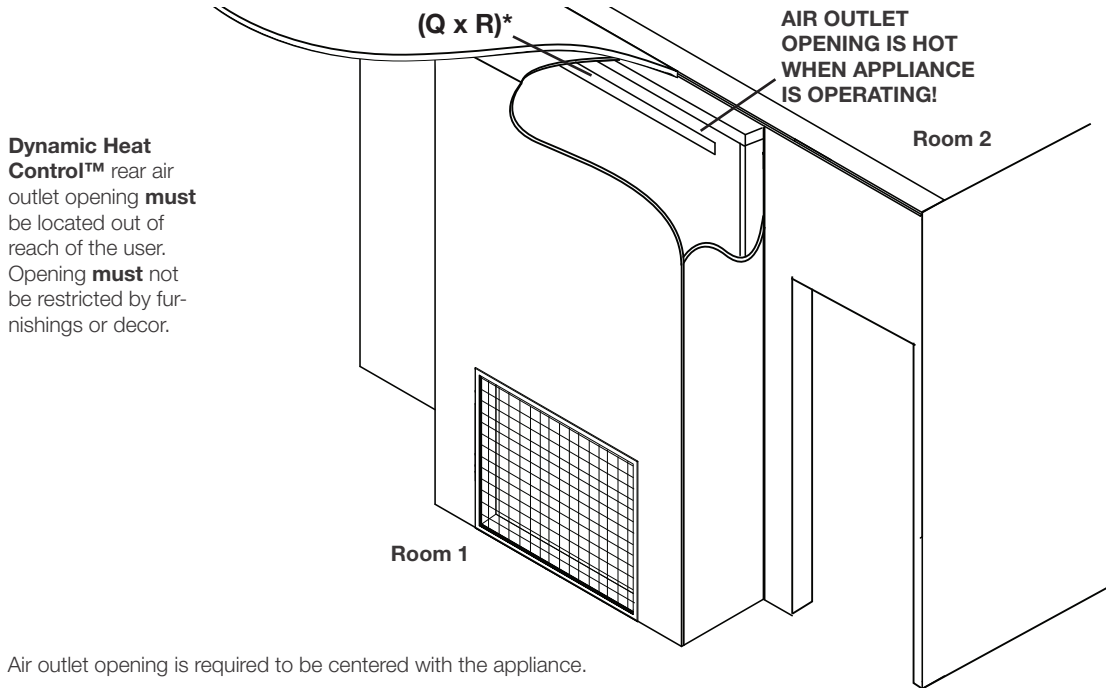

## ! WARNING

- **When using a rear air outlet opening, it is critical that the adjoining room or living spaces are in direct air communication (i.e. of an open plan configuration or connected by a permanently open doorway or archway). This prevents the appliance from being in a negative pressure more than that of the adjoining room. Failure to follow these requirements can result in reversing the Dynamic Heat Control™ air flow and will cause the appliance, safety barrier, and finishing materials to overheat, creating a fire hazard.**

### note:

Increasing the air outlet opening will allow the appliance, the barrier, the temperatures on the surfaces above the fireplace opening, and the enclosure be at cooler temperatures. It will also allow the air to circulate more effectively in the room. **However, if the appliance is equipped with the Dynamic Heat Control™ Plus, then the opening size must be 120 sq. in..**

**note:**

**Dynamic Heat Control™** can be installed with both front and rear air outlet openings to allow heat to circulate in two rooms, however, it is recommended to install the air outlet opening at different heights that meet the installation parameters for aesthetic purposes. For **Dynamic Heat Control™ Plus**, a second opening **MUST NOT** be installed.

## 2.4 installation option 4 - open enclosure with hard combustible valance

**NOT suitable for Dynamic Heat Control™ Plus**

**Installation Option 4** (open enclosure with hard combustible valance) is similar to **Installation Option 1** with the addition of a hard combustible valance. Minimum opening dimensions and valance dimensions **must** be followed. **Restricting air movement within the valance area will overheat the appliance, the enclosure, and finishing material.**

**note:**

Air outlet opening must be at least continuous around the top of the enclosure for a valance to be permitted. Using the minimum air outlet opening from **Installation Option 2** and **Option 3** is not permitted and will overheat the appliance.

**DYNAMIC HEAT CONTROL™ AIR OUTLET OPENING IS HOT WHEN APPLIANCE IS OPERATING!**

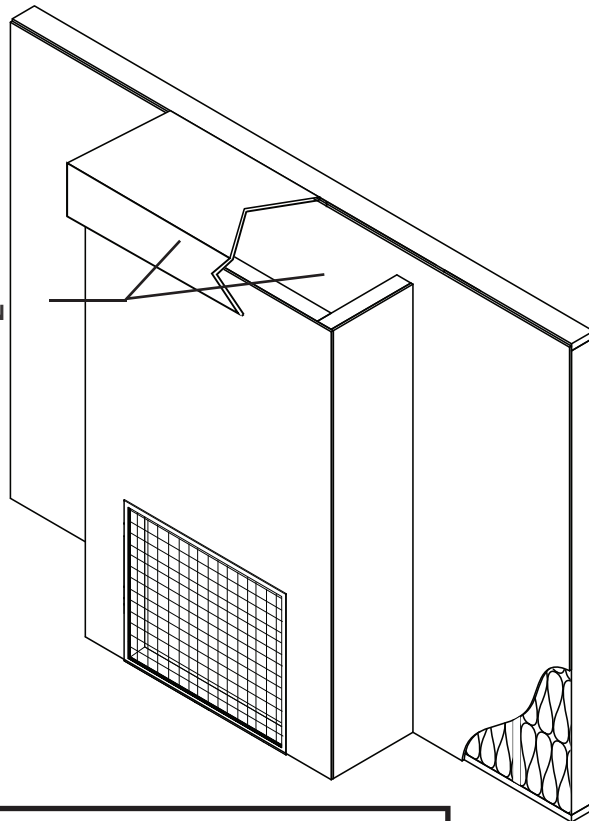

Air outlet opening must be located out of reach of the user.  
Air outlet **must** not be restricted by furnishings or decor.

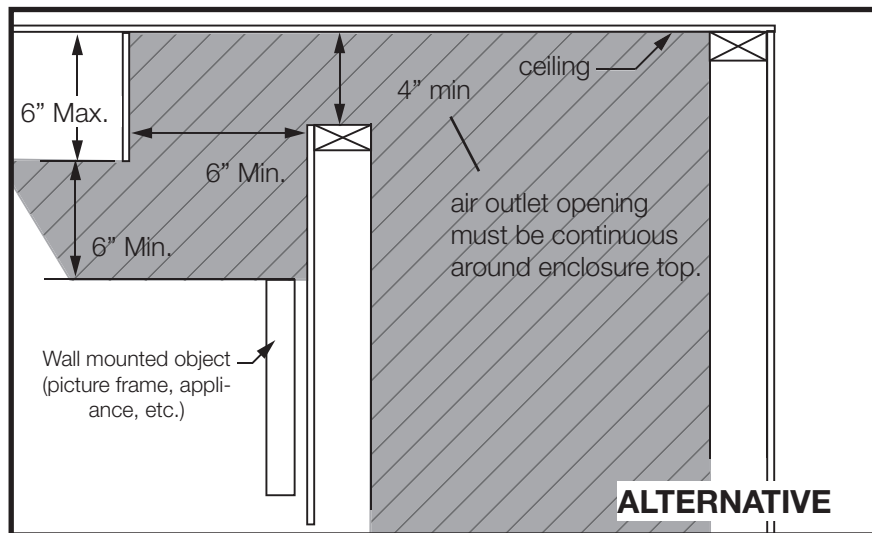

ABSOLUTELY NO OBSTRUCTION OR RESTRICTION ALLOWED IN THE ENTIRE SHADED AREA WITH THE EXCEPTION OF APPROVED VENTING

# installation planning

## 2.5 installation option 5 - side openings

**Suitable for Dynamic Heat Control™ Plus**

**Installation Option 5** (side openings) requires **two (2)** air outlet openings to be framed no more than 1.5” below the enclosure top to avoid trapping heat in the upper areas and the air outlet opening centered on the appliance center. Minimum air outlet opening dimensions **must** be followed. **Framing the air outlet opening lower will overheat the appliance, the enclosure, and finishing material.**

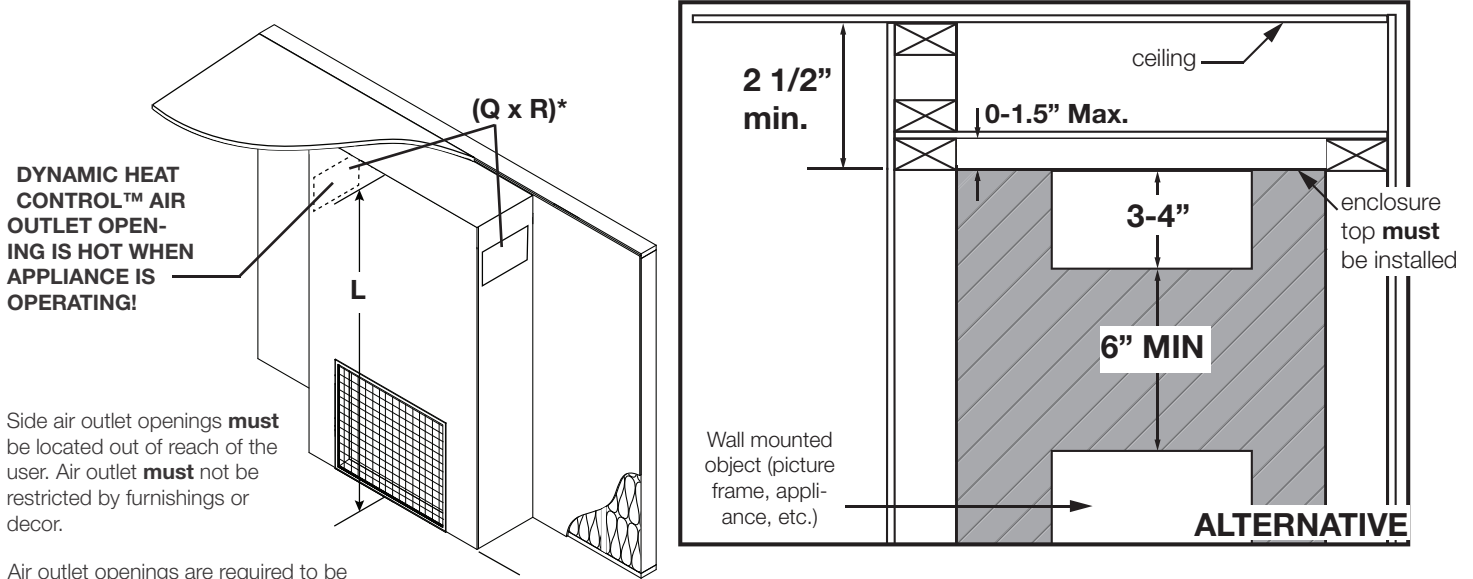

Side air outlet openings **must** be located out of reach of the user. Air outlet **must** not be restricted by furnishings or decor.

Air outlet openings are required to be centered with the appliance.

**MINIMUM AIR OUTLET OPENING DIMENSIONS**

	EX36	EX42
<b>(Q x R)*</b>	2x 56 sq. in. openings minimum (Q <b>must</b> be 3-4")	
<b>L</b>	72"	

**\*Grills, grates, louvers, or other covers are only permitted if the free area is equal to or greater than the required minimum opening size listed above.**



**top view**  
(frame and deflectors not shown)

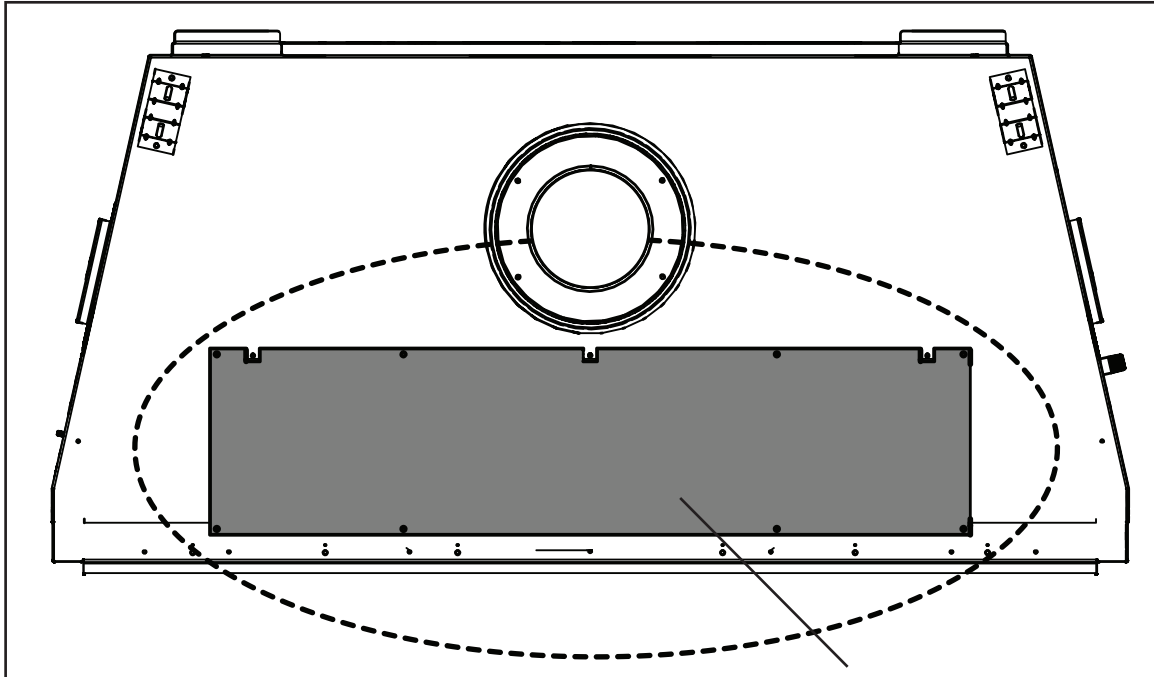

**Header shield not illustrated.**

For plate removal, see "Dynamic Heat Control™ installation" section.

**side view**

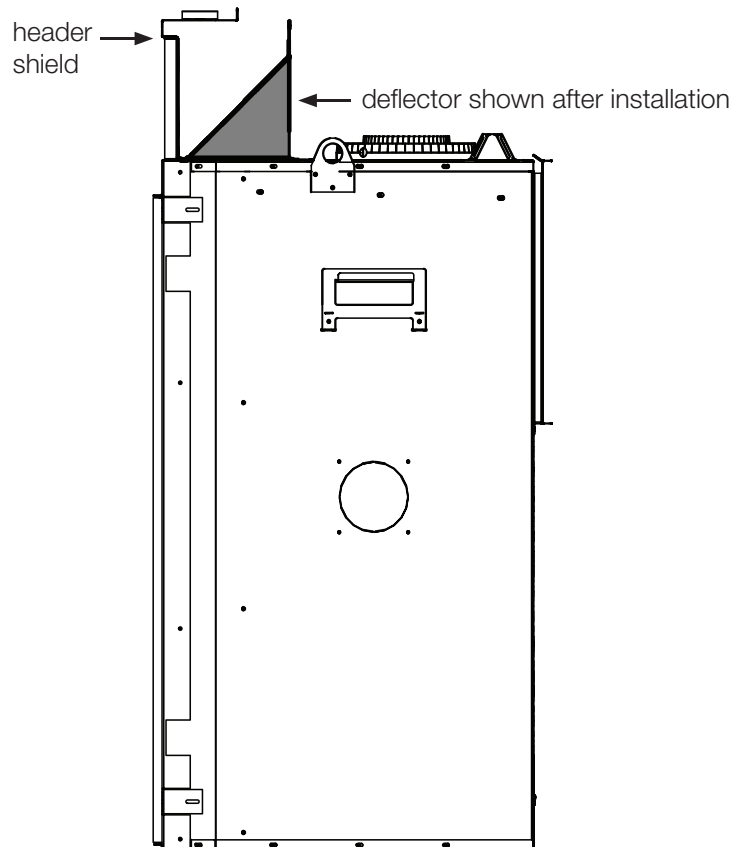

## EN 4.0 Dynamic Heat Control™ installation

Before starting the Dynamic Heat Control™ installation, remove the barrier. Refer to the appliance installation manual.

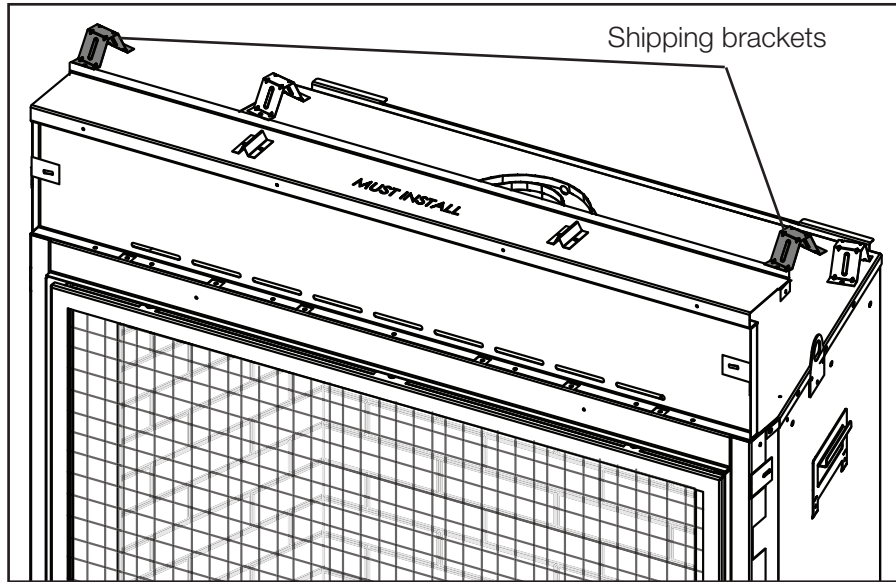

**note:**

The shipping brackets **must** only be removed from the header shield if the enclosure is recessed.

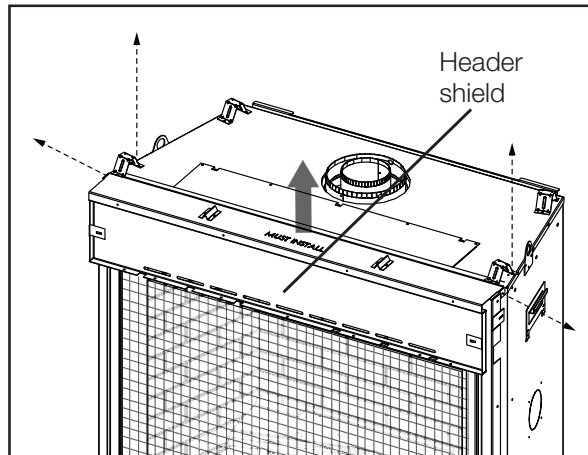

1. Remove fasteners securing header shield. **Do not discard fasteners.**

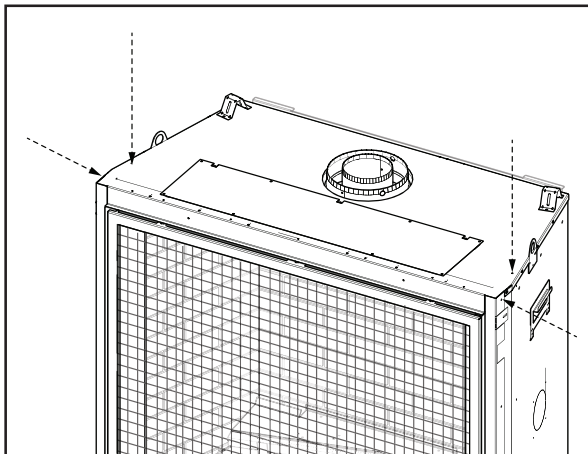

2. Once the header shield is removed, replace the 4 screws removed in step 1.

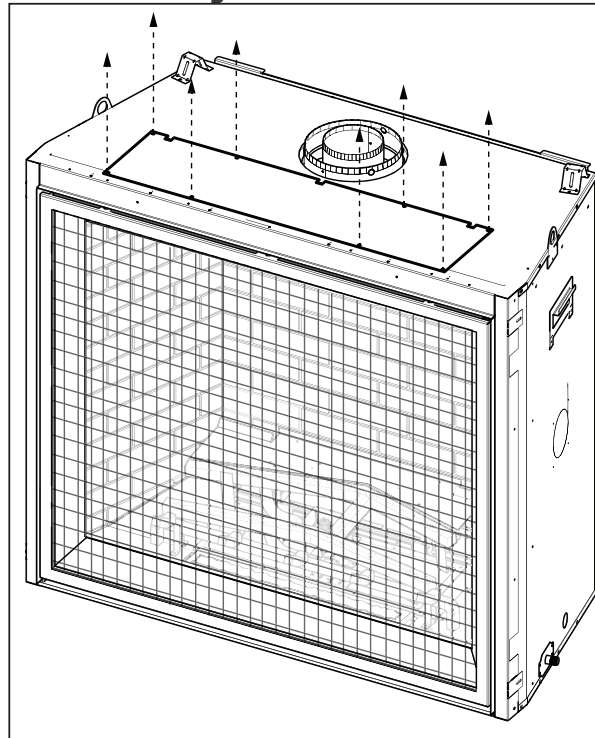

3. Remove the plate.

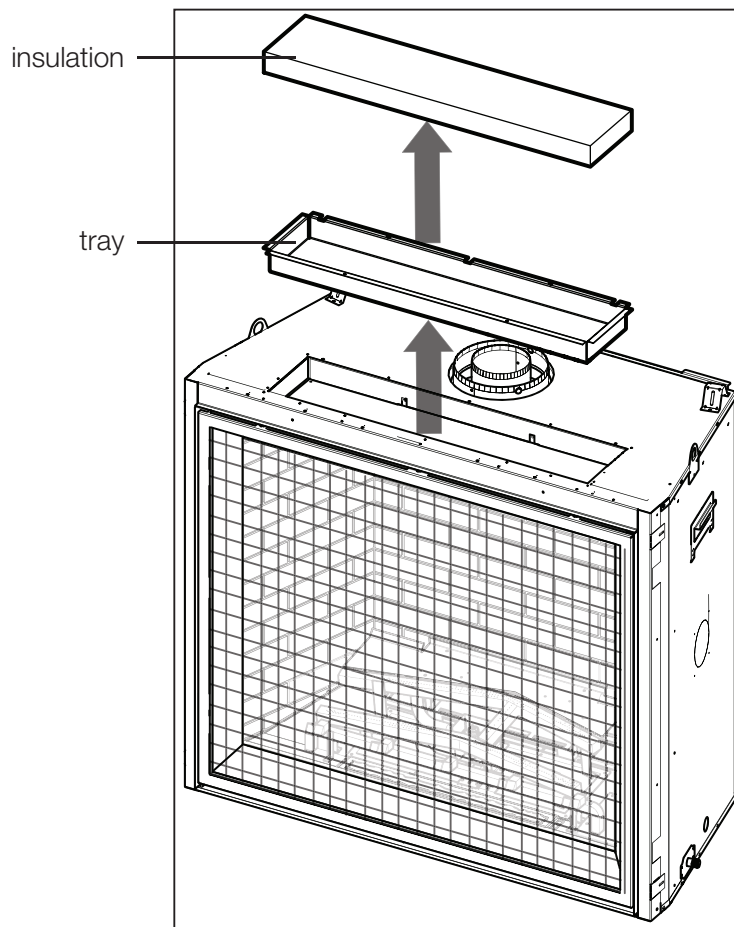

4. Remove the insulation and tray and discard.

**IMPORTANT:**

**Fire Hazard Warning:** This step is crucial for your appliance to work properly. If the insulation AND tray are not removed, the appliance will overheat, the barrier will become excessively hot, and the high limit switch will constantly trip.

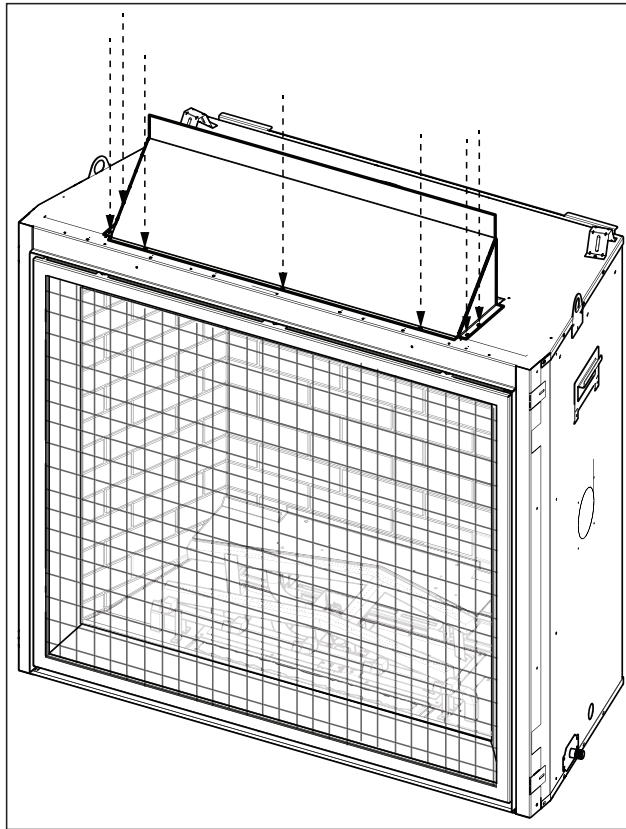

5. Install the deflector using the fasteners supplied.

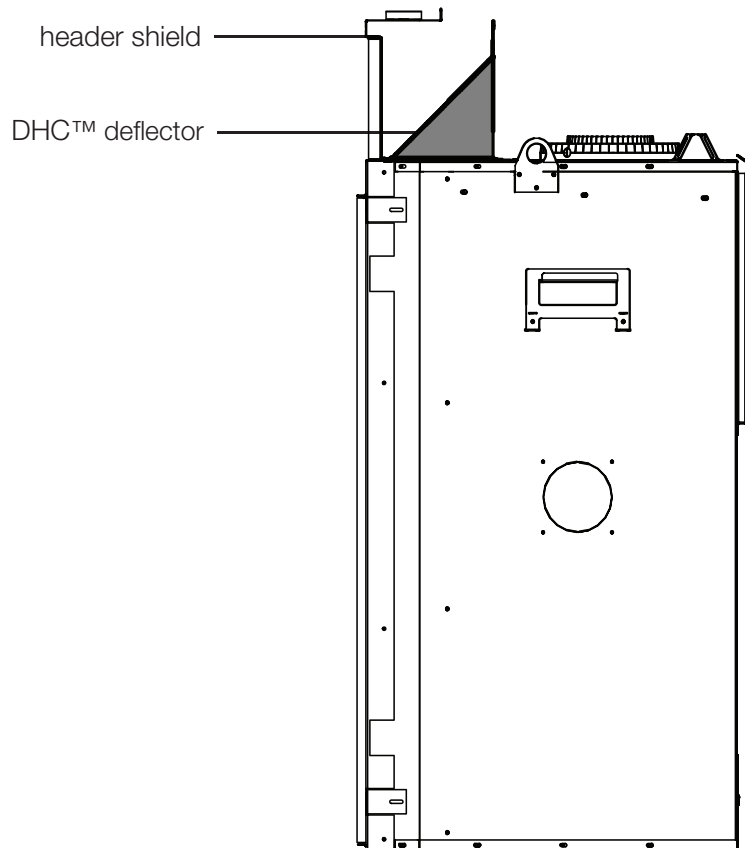

6. Reinstall header shield using fasteners supplied.

## 4.1 high limit switch installation

### **! WARNING**

- High Limit Switch installation is **MANDATORY**. Failure to correctly install will cause a fire hazard.

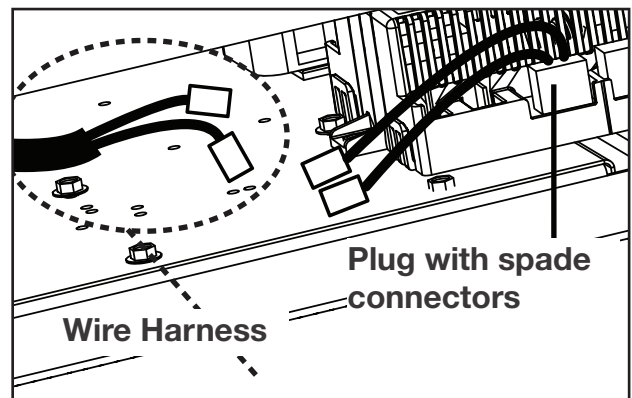
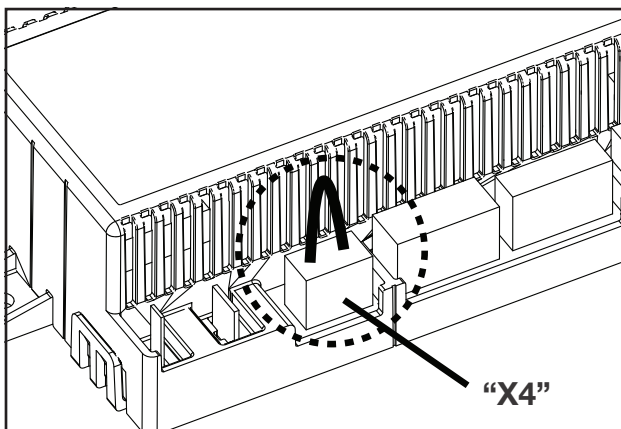
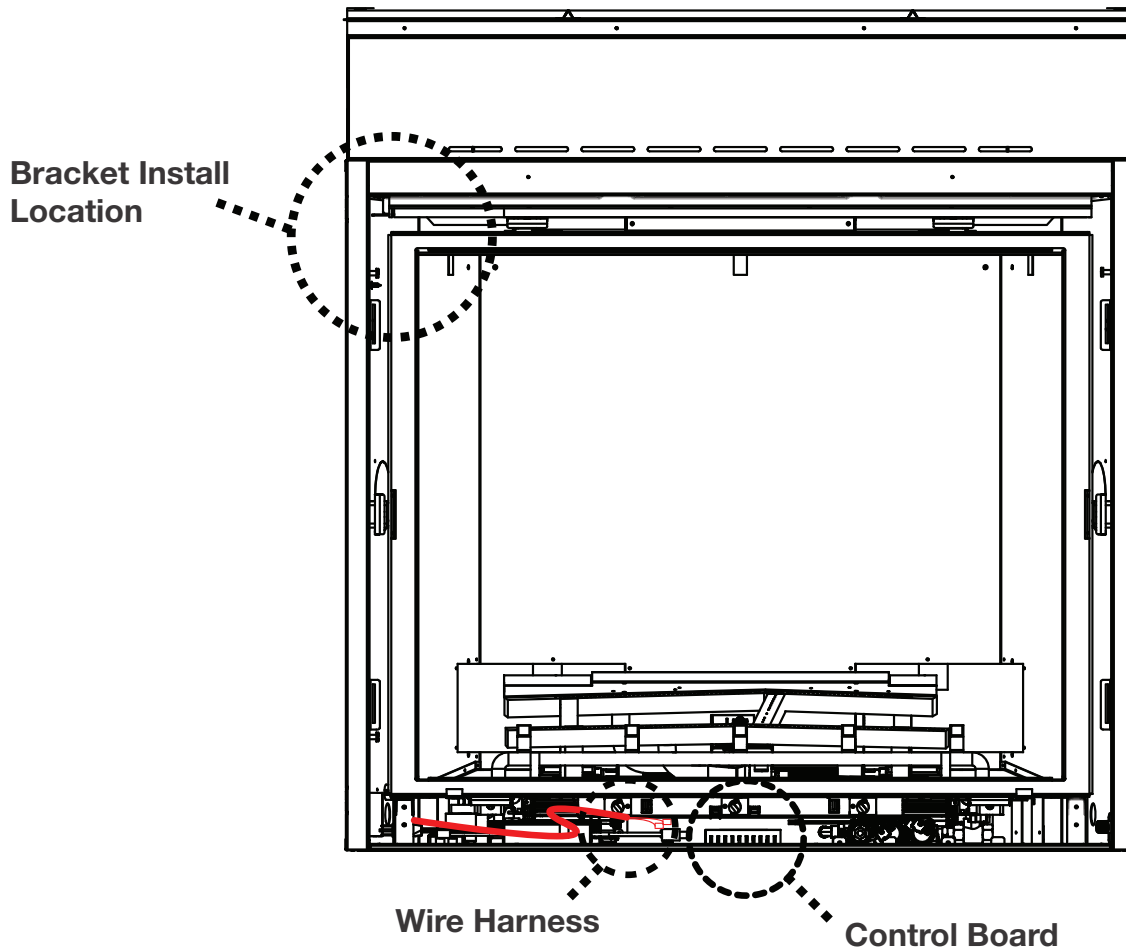

1.) Remove jumper plug from control board (marked "X4") and install plug with spade connectors to the control board. Discard the original jumper plug.

# Dynamic Heat Control™ installation

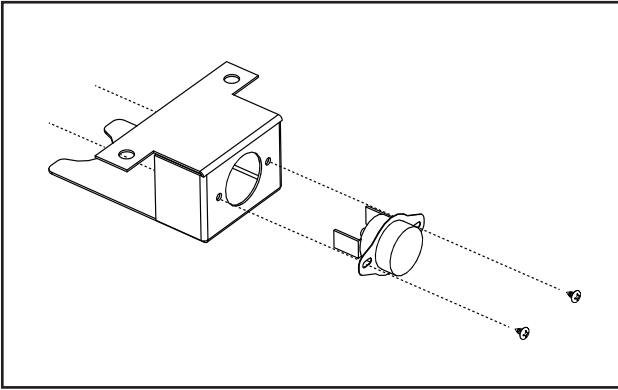

3.) Insert the high limit switch into the bracket and secure with two fasteners (supplied).

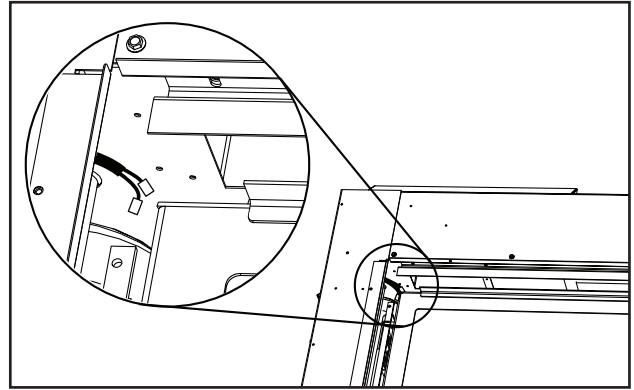

4.) Locate the existing wire harness in the upper left corner of the firebox (as illustrated). Connect wires to the high limit switch.

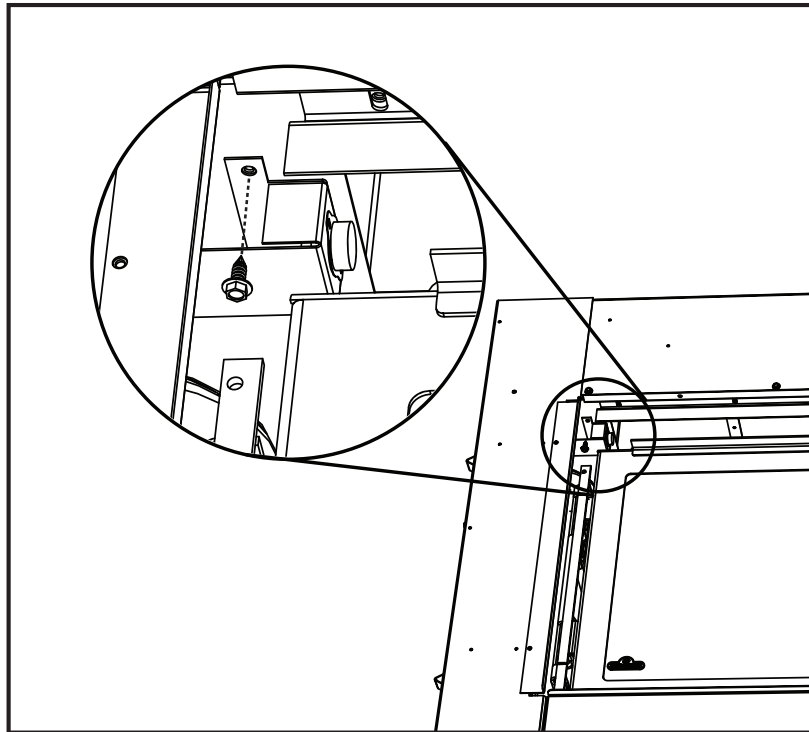

5.) Install high limit switch assembly to the bracket install location in the upper left hand corner of the appliance. Secure high limit switch assembly with a supplied screw as shown.

## IMPORTANT:

**After installing the Dynamic Heat Control™ system, ensure appliance is clean from dust, debris, etc. before continuing with the appliance installation. Take precautions to ensure framing or finishing dust and debris does not enter the air outlet openings or deflectors.**

**Check and clean appliance before operation.**

**Re-install safety barrier. Refer to “safety barrier installation / removal” in the appliance installation manual.**

## 5.0 minimum framing dimensions

EN

**note:**

When using optional finishing accessories, the framing dimensions and finishing materials may differ from what is outlined in the section below; refer to the leaflet instructions supplied in the accessory kit for specific framing and finishing specifications.

### ! WARNING

- Risk of fire!
- In order to avoid the possibility of exposed insulation or vapour barrier coming in contact with the appliance body, it is recommended that the walls of the appliance enclosure be "finished" (i.e. drywall / sheetrock), as you would finish any other outside wall of a home. This will ensure that clearance to combustibles is maintained within the cavity.
- Do not notch the framing around the appliance stand offs. Failure to maintain air space clearance may cause over heating and fire. Prevent contact with sagging or loose insulation or framing and other combustible materials. Block opening into the chase to prevent entry of blown-in insulation. Make sure insulation and other materials are secured.
- Minimum clearance to combustibles must be maintained or a serious fire hazard could result.

**note:**

For heavier finishing materials such as marble, we recommend adding extra support to the frame. Ensure there is adequate floor support for the appliance and finishing material.

### minimum framing dimensions

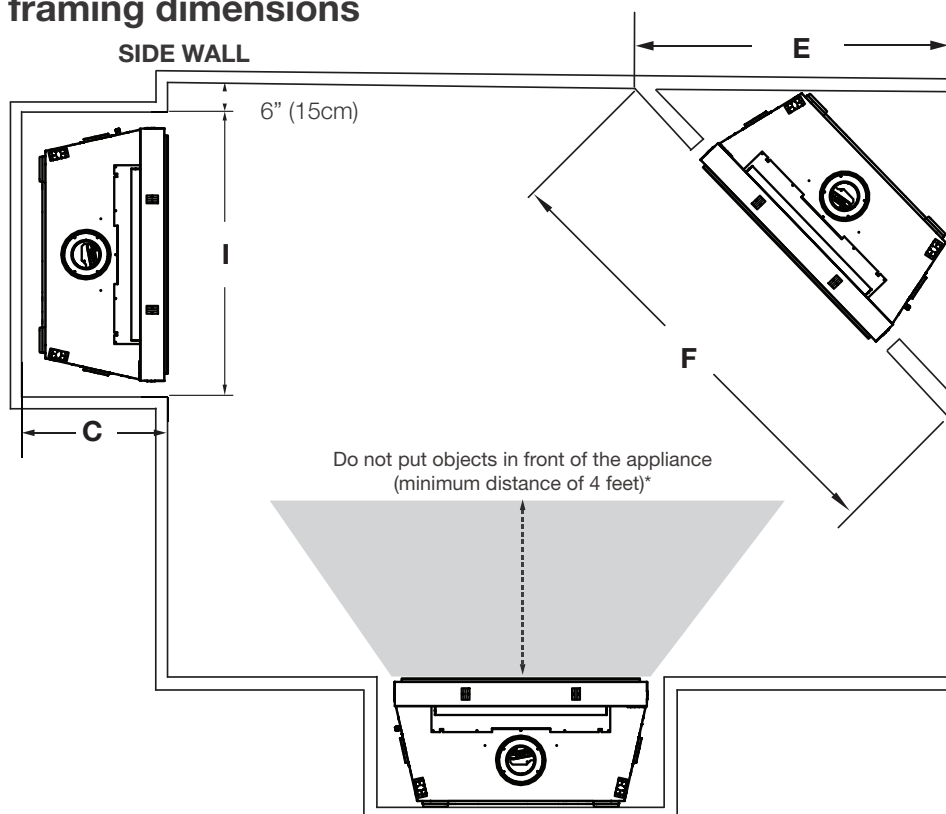

**Horizontal vent sections:** A minimum clearance of 3" (76mm) on the top of the vent to combustibles and 2" (51mm) on the sides and bottom of the vent to combustibles is required.

**Vertical vent sections:** A minimum clearance of 1" (25mm) all around the vent pipe on all vertical runs to combustibles is required.

	EX36	EX42
I	39 3/4"	45 3/4"
C	22 1/4"	
E	53 3/8"	57 13/16"
F	75 1/2"	81 11/16"

# 6.0 minimum clearance to combustible enclosures

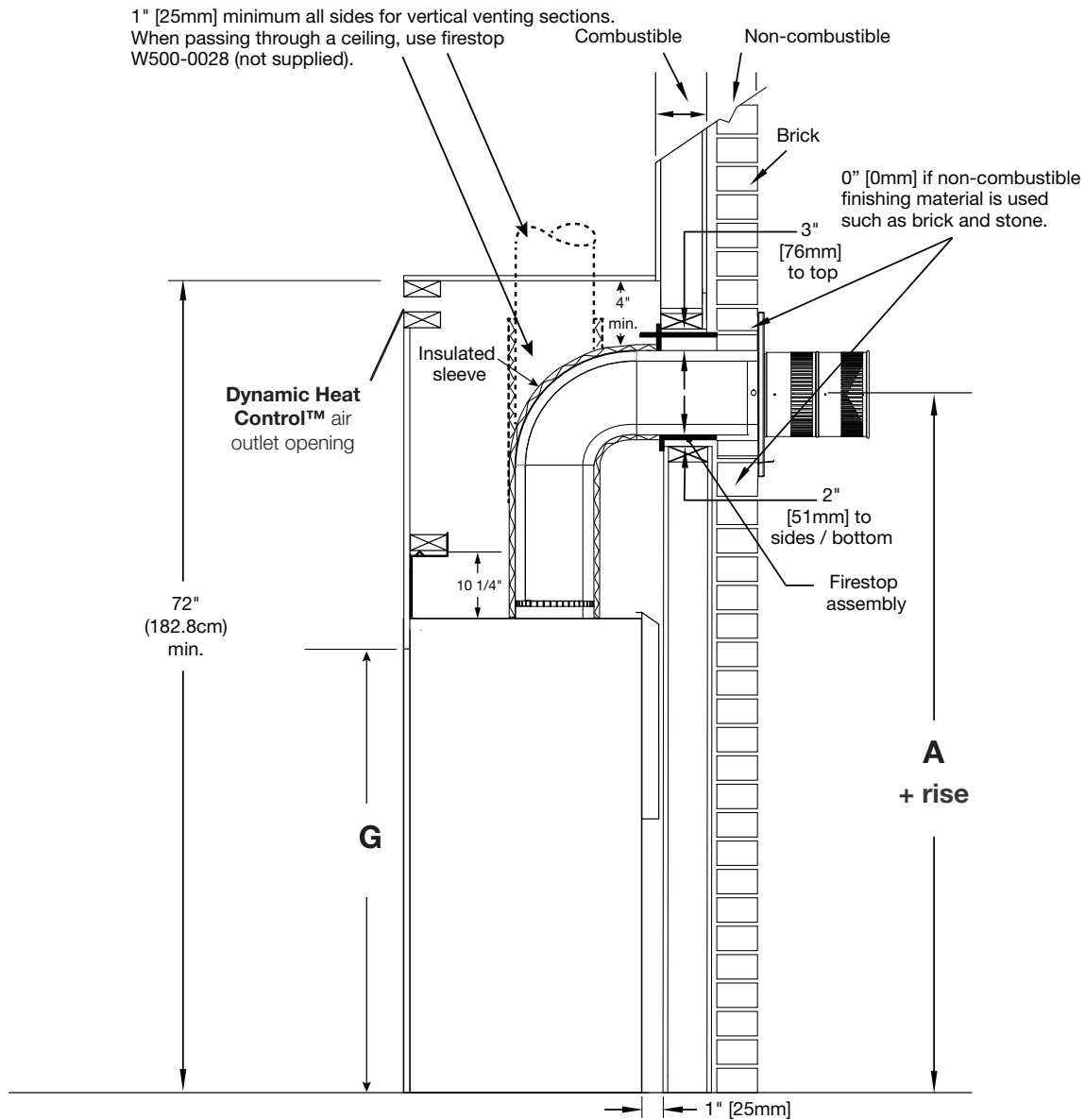

\* Refer to “venting requirements” and “venting installation” sections.

\*\* Clearances within the enclosure may be higher (refer to “minimum framing dimensions” section).

	EX36	EX42
A	59"	63"
G	33 1/8"	37 1/8"

**Horizontal vent sections:** A minimum clearance of 3" (76mm) on the top of the vent to combustibles and 2" (51mm) on the sides and bottom of the vent to combustibles is required.

**Vertical vent sections:** A minimum clearance of 1" (25mm) all around the vent pipe on all vertical runs to combustibles is required.

**note:**

The Elevation series requires a minimum inside enclosure height (as illustrated) measured from the bottom of the appliance. For temperature requirements, this area must be left unobstructed. Some venting configurations that require more vertical rise will require a larger enclosure to provide minimum vertical clearance between vent pipes and combustibles.



## 7.0 rough framing - before appliance installation

EN

Before framing your appliance, determine vent requirements before deciding the final location of the appliance. After rough framing, place the appliance in its final position. Also, see appliance manual for vent shield installation, nailing tabs installation, electrical installation, gas installation, etc.

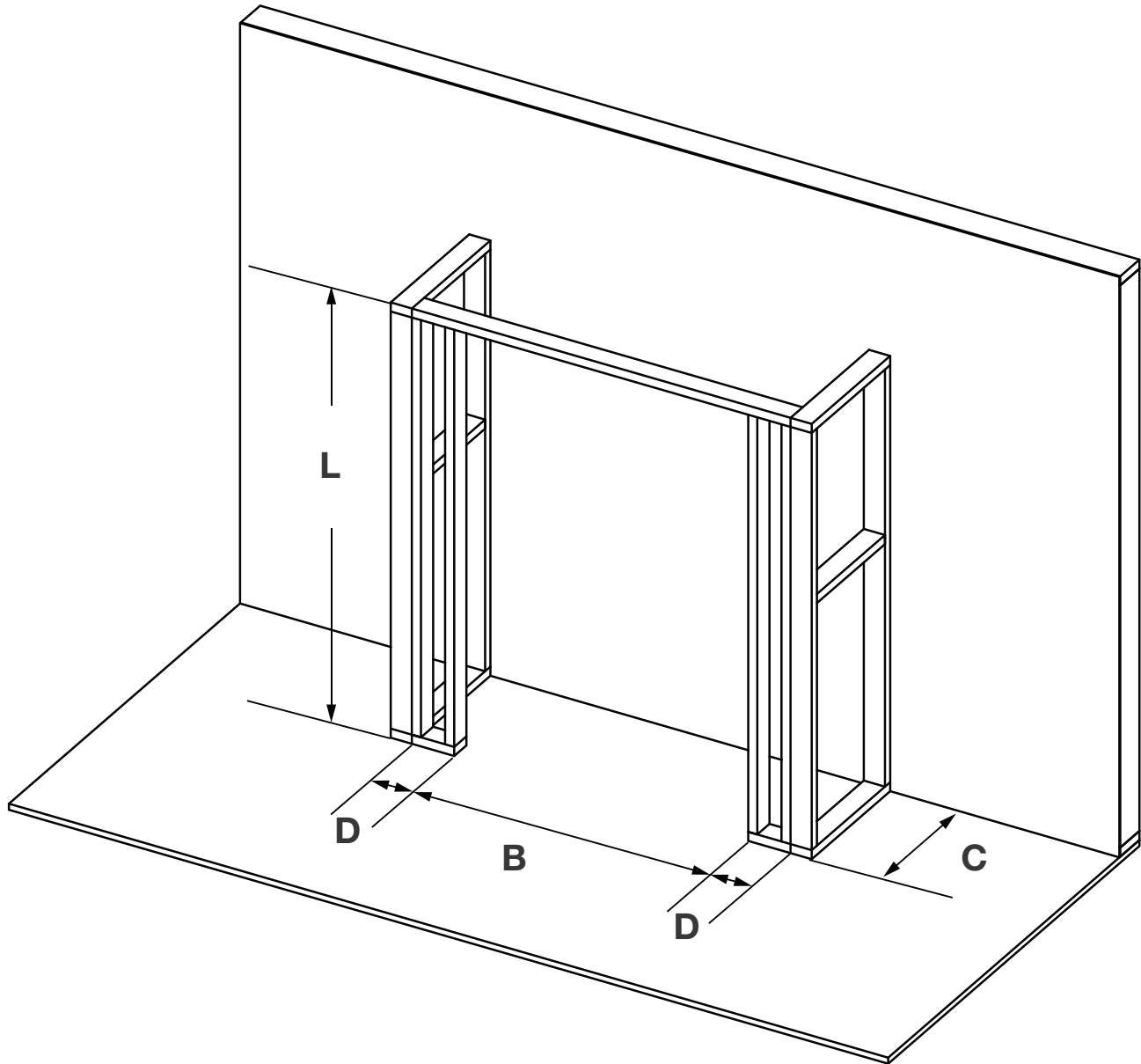

**note:**

The Elevation series requires a minimum enclosure height (as illustrated), measured from the bottom of the appliance. For temperature requirements, this area must be left unobstructed. Some venting configurations that require more vertical rise will require a larger enclosure to provide minimum vertical clearance between vent pipes and combustibles.

Ref	EX36	EX42
B	42 3/4"	48 3/4"
C	22 1/4"	
D	6"	
L	72"	

## 8.0 finish framing - after appliance installation

There are various methods to ventilate the enclosure. Refer to "installation planning" section. Only two options are illustrated - **installation option 2** and **installation option 5**.

The appliance must be installed at this point of framing. Appliance is not shown to better illustrate framing.

### flush

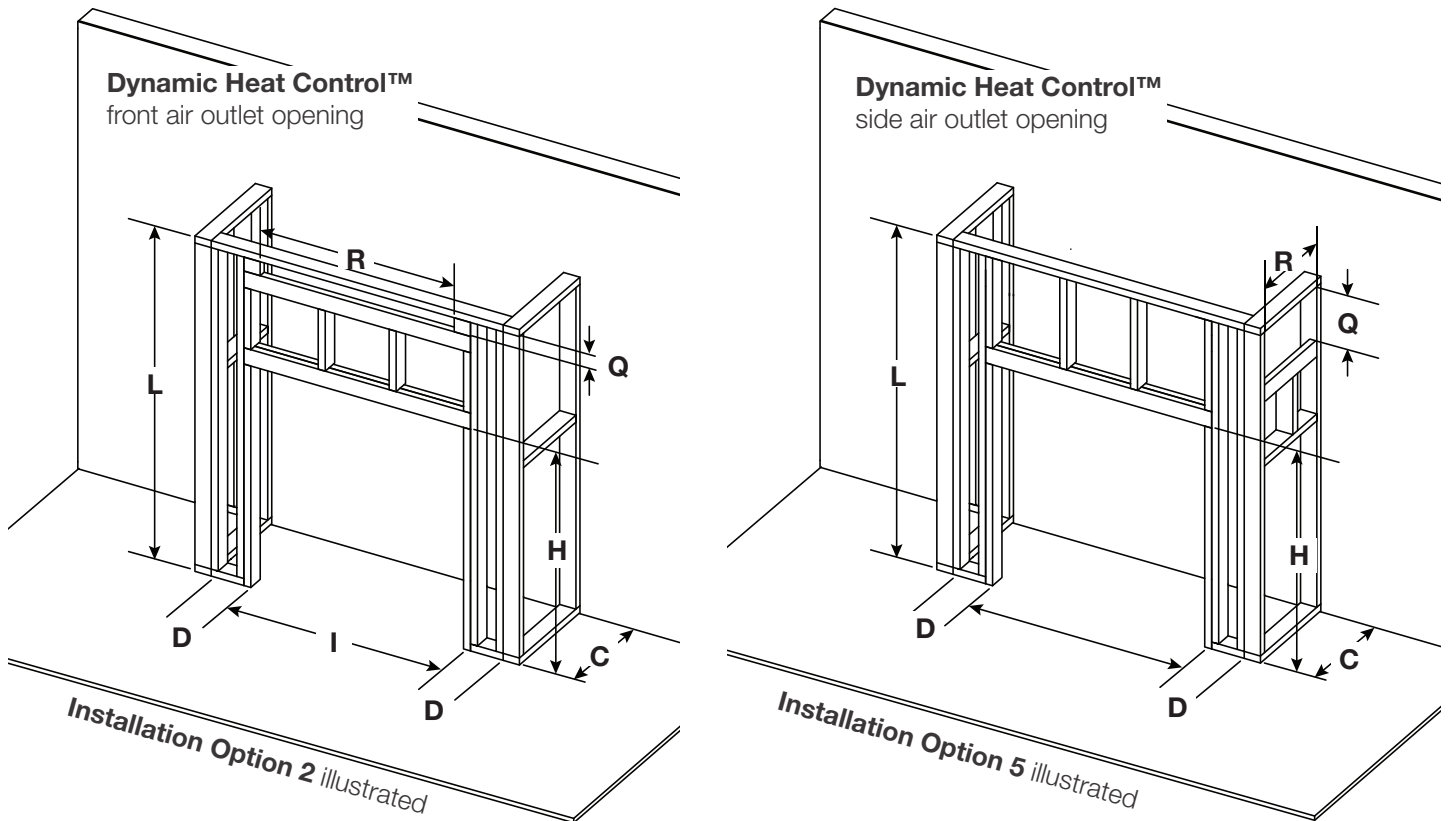

#### note:

Finish framing **must** be built after appliance has been placed in its final position and venting connected.

### minimum framing

Ref	EX36	EX42
I	39 3/4"	45 3/4"
C	22 1/4"	
D	6"	
H	43 3/4"	47 3/4"
L	72"	
Q*	2" min and 3" max	
(Q x R)*	112 sq. in.	

\* ONLY APPLICABLE TO OPTION 2, 3 and 5 - Opening **must** be centered in enclosure on appliance. Dimensions represent finished sizes and where applicable should be adjusted to include finish material thickness.

#### note:

The Elevation series requires a minimum enclosure height (as illustrated) measured from the bottom of the appliance. For temperature requirements, this area must be left unobstructed. Some venting configurations that require more vertical rise will require a larger enclosure to provide minimum vertical clearance between vent pipes and combustibles.

## recessed

### **! WARNING**

- Shaded components (finish framing) **must** be non-combustible materials.

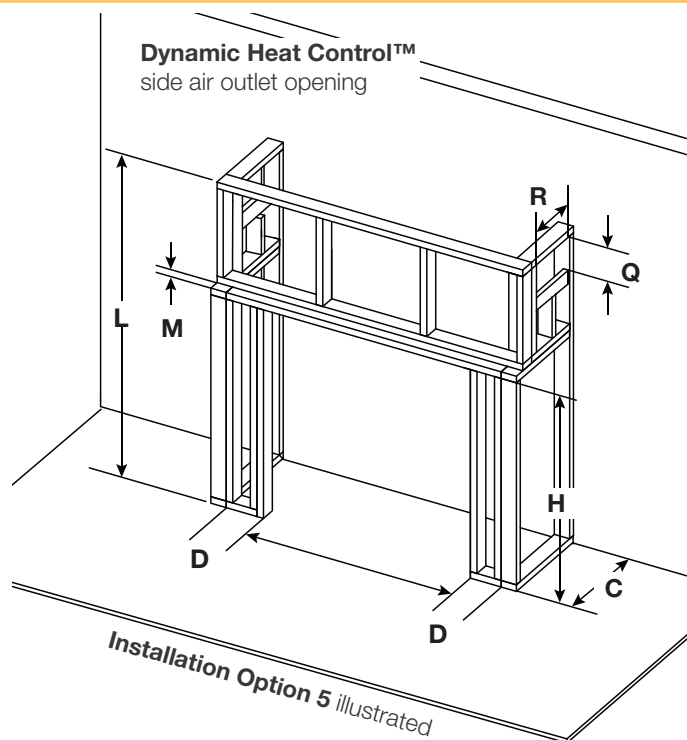
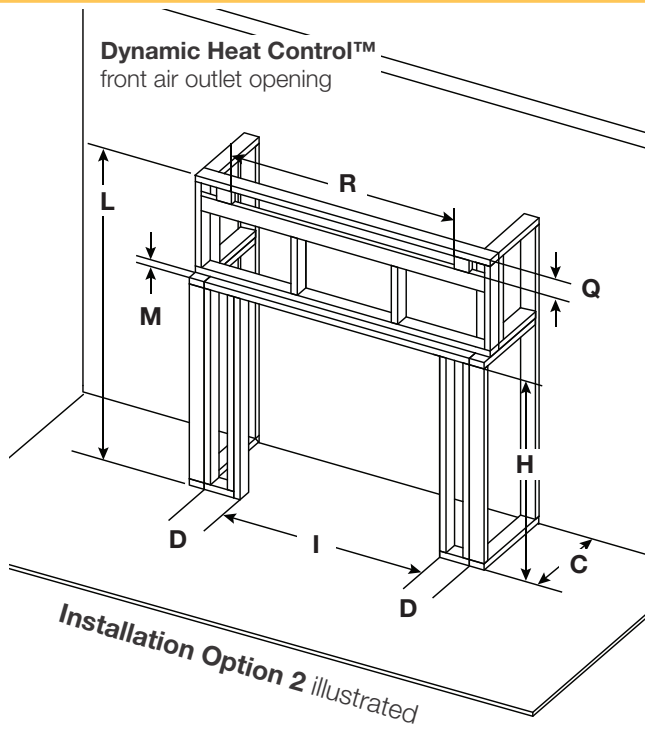

**note:**

Finish framing **must** be built after appliance has been placed in its final position and venting connected.

**This configuration also requires recess area to use non-combustible facing due to close proximity to vent.**

Recessed volume must be added to the overall size of enclosure.

### minimum framing

Ref	EX36	EX42
I	39 3/4"	45 3/4"
C	22 1/4"	
D	6"	
H	43 3/4"	47 3/4"
L	72"	
Q*	2" min and 3" max	
(Q x R)*	112 sq. in. min.	
M**	3", 6" max	

\* ONLY APPLICABLE TO OPTION 2, 3 and 5 - Opening **must** be centered in enclosure on appliance. Dimensions represent finished sizes and where applicable should be adjusted to include finish material thickness.

**note:**

The Elevation series requires a minimum enclosure height (as illustrated) measured from the bottom of the appliance. For temperature requirements, this area must be left unobstructed. Some venting configurations that require more vertical rise will require a larger enclosure to provide minimum vertical clearance between vent pipes and combustibles.

With Dynamic Heat Control™, you can finish the appliance with any combustible materials. Air outlet opening must be located out of reach of the user. Air outlet opening **must** not be restricted by furnishings or decor.

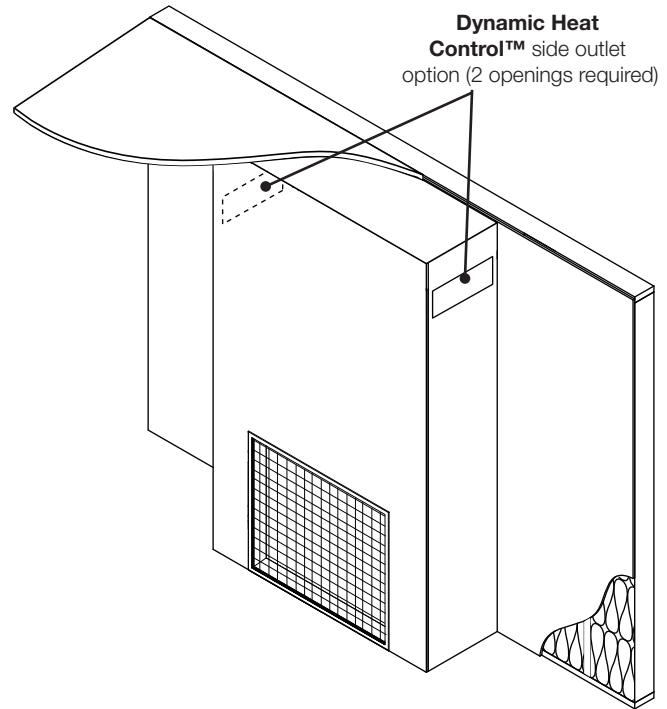
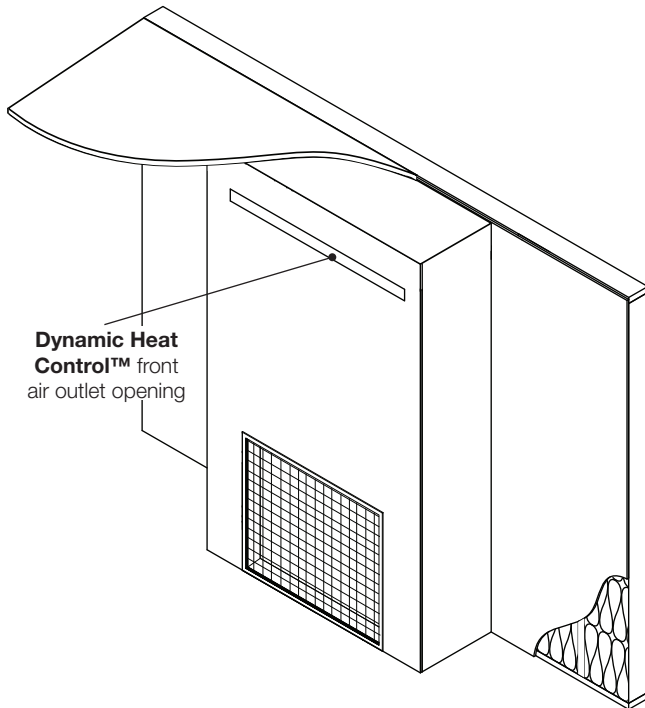

### Recessed installation with Dynamic Heat Control™

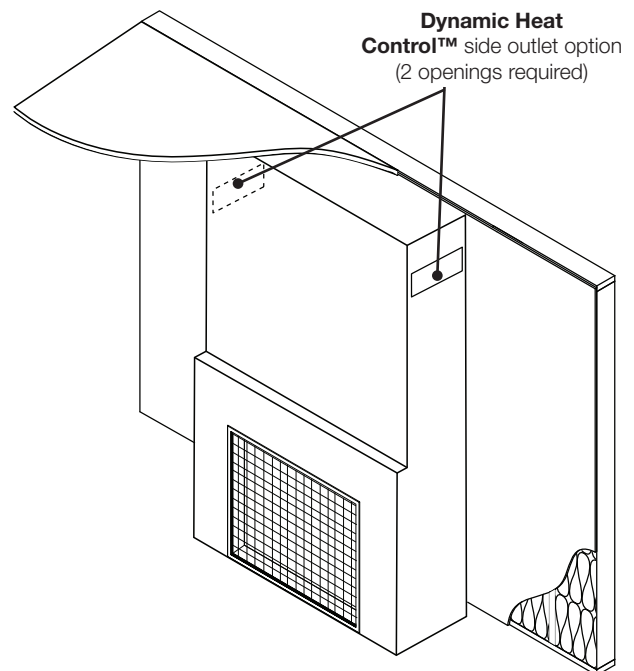
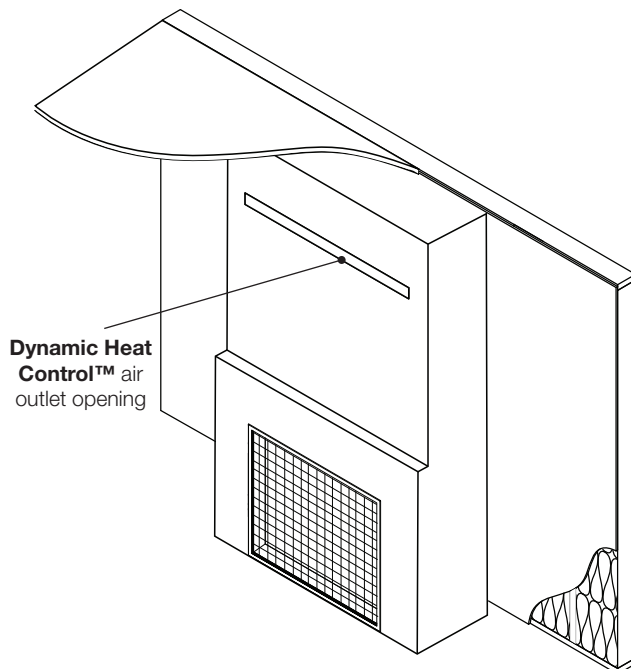

**note:**

Recessed volume must be added to the overall size of enclosure.

## 9.1 enclosure design

Additional openings in the enclosure are not acceptable since the DHC™ system relies on the “chimney effect” created through the appliance and the enclosure.

By adding additional air inlet(s) to an enclosure, air can bypass the appliance, which increases the operating temperature of the appliance and around the appliance opening. This is counterproductive to the benefits of heat management and, in extreme cases, the appliance may become hot enough for the high limit switch to trip.

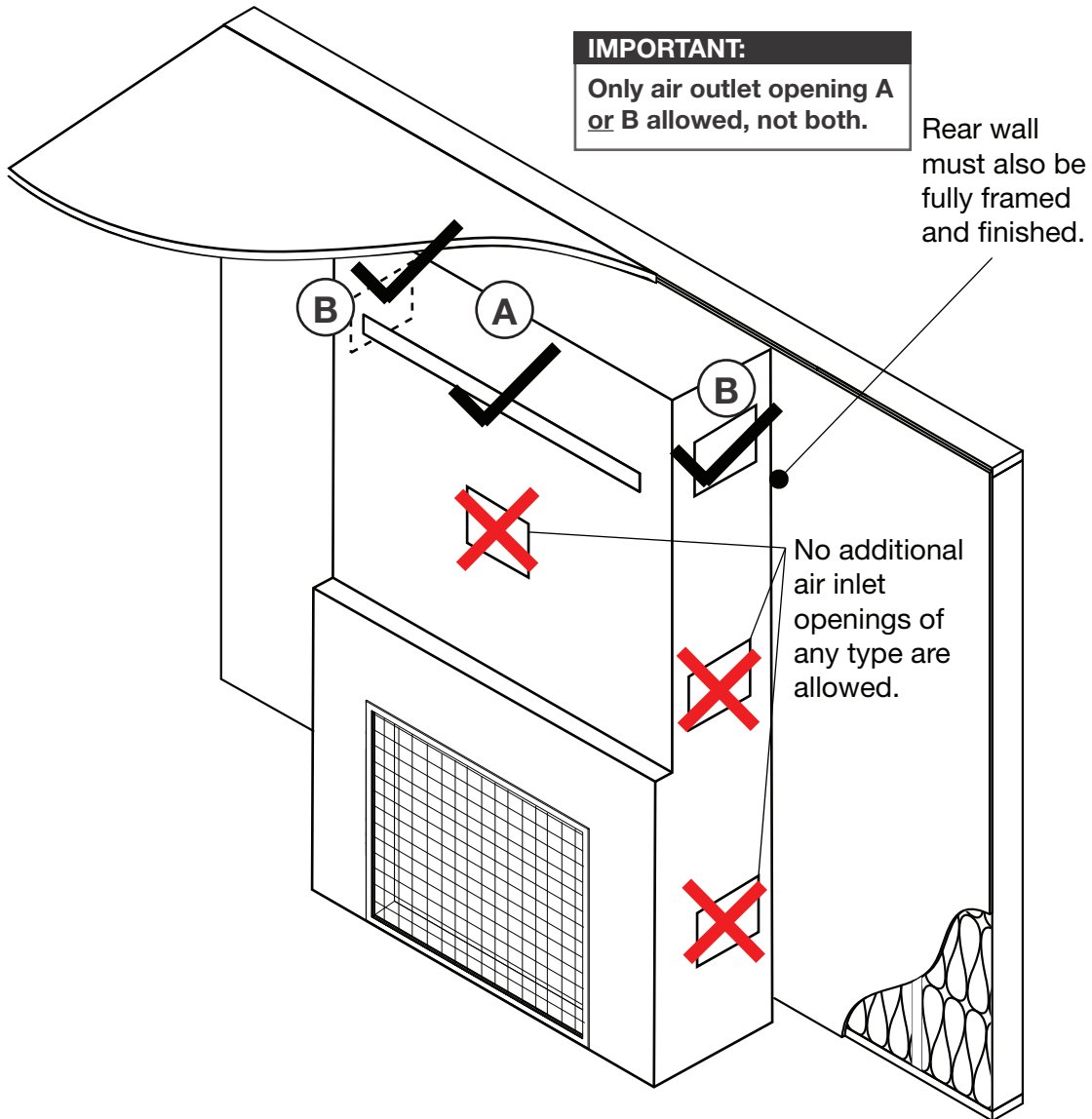

**note:**

The outside of the enclosure must be finished on all four sides and must include a complete floor.

## 9.2 optional trim finishing

When the appliance is installed with the front (or rear) air outlet opening, a decorative trim kit is available to finish your installation. The trim kit can be painted as an accent colour or to blend in with room decor.

**The minimum air opening area must be maintained after the finishing material has been installed.**

Contact your local authorized dealer for more information.

**note:**

The inner surfaces may be visible.

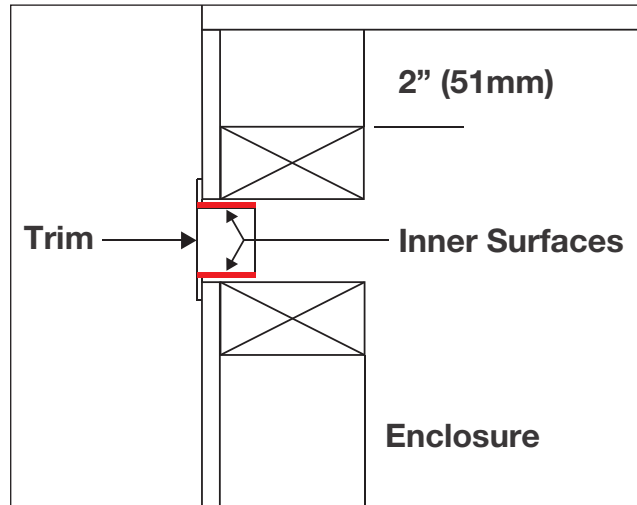

# 10.0 minimum combustible mantel clearances

## ! WARNING

- Risk of fire. Maintain all specified air space clearances to combustibles. Failure to comply with these instructions may cause a fire or cause the appliance to overheat. Ensure all clearances (i.e. back, side, top, vent, mantel, front, etc.) are clearly maintained.
- When using paint or lacquer to finish the mantel, the paint or lacquer must be heat resistant to prevent discolouration.
- Installing a television or other electronics above the appliance may cause discolouration, melting, or damage to the electronics. Use clearances as guidelines and refer to your TV manufacturer's instructions for further information.

Installing a mantel between this appliance and electronics or other materials that may be sensitive to heat, will reduce the effect of direct heat on them. Follow mantel height and depth instructions for proper clearance information. A non-combustible mantel is considered a non-combustible protrusion

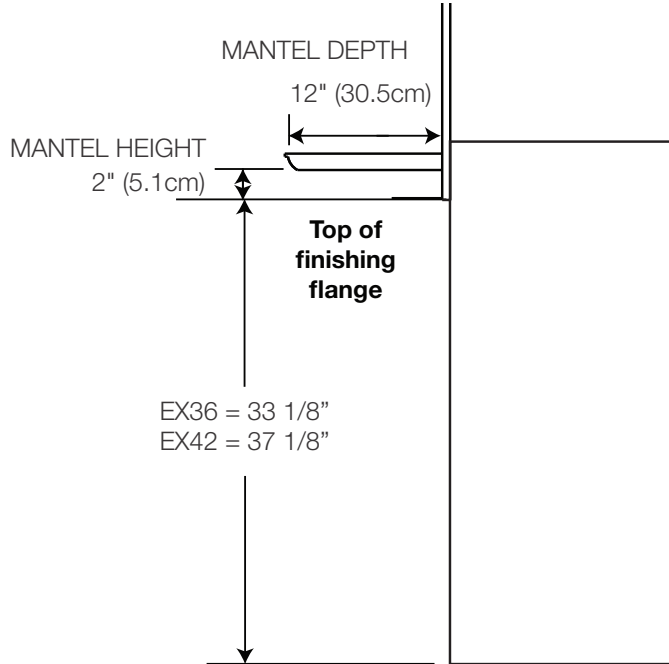

Electronics, picture frames, decors, or other wall-mounted objects must be 6" below the air outlet opening and 6" above the finishing flange.

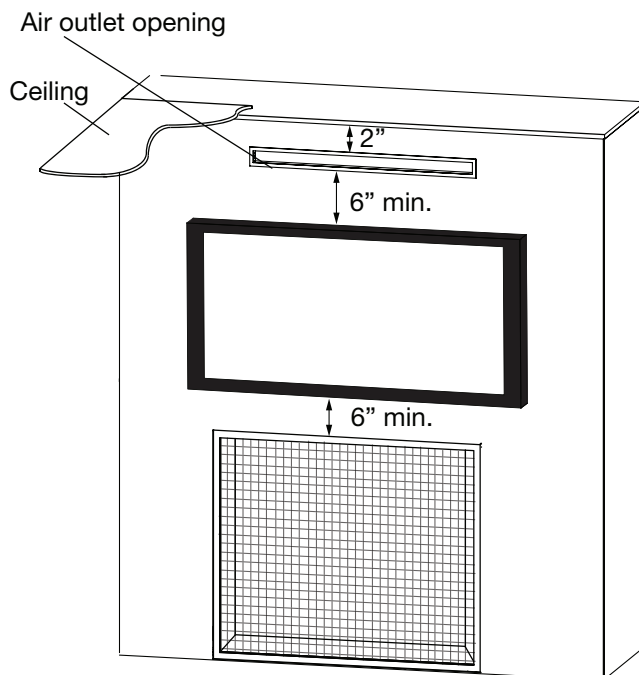

# 11.0 maximum protrusion

## ! WARNING

- Finishing material tight to the frame around the finishing flange must not project more than 4" (38mm) from the face of the safety barrier (above the door and sides only).

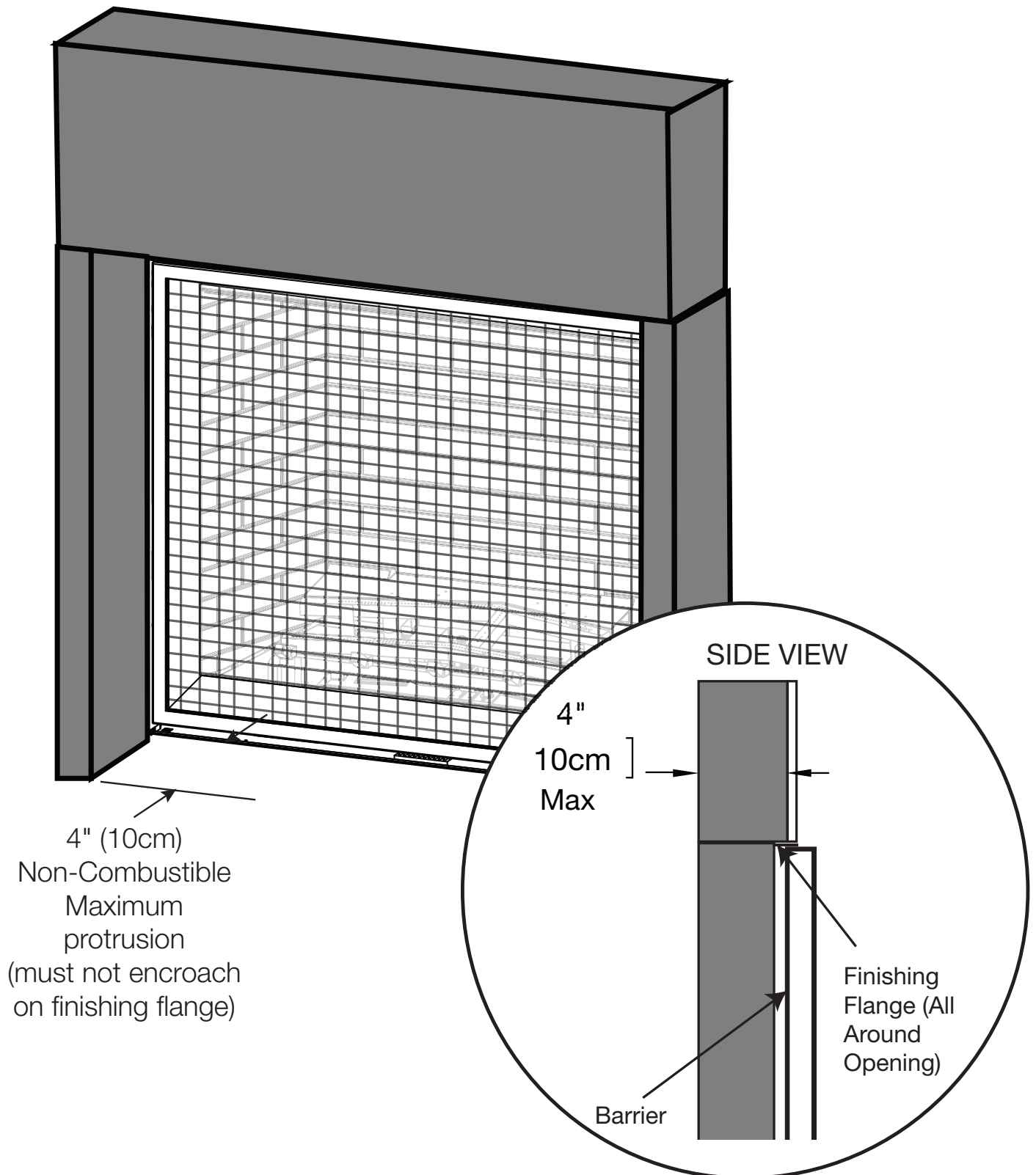



## **! WARNING**

- Ensure knockout plates on the fixed side are not removed or damaged.

- Header shield installed
- Housing cap removed
- Insulation removed
- Housing tray removed
- Deflector installed
- High limit switch installed
- Wire harness connected to high limit switch and control board.
- Safety Barrier installed
- Framing
- Clean all dust and debris
- Finish the appliance
- Installation of **Dynamic Heat Control™** recorded in owner's manual.

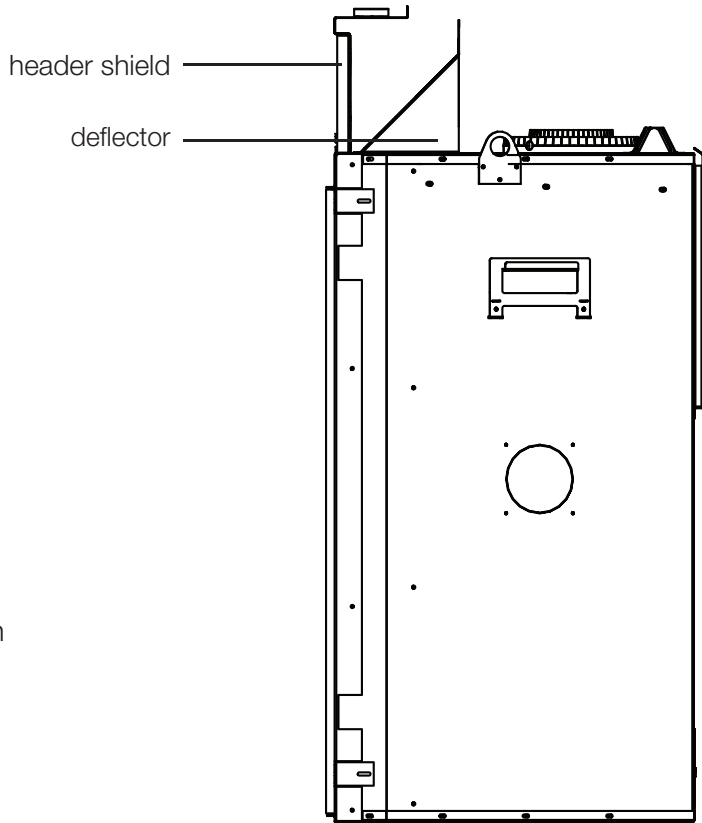

**side view**

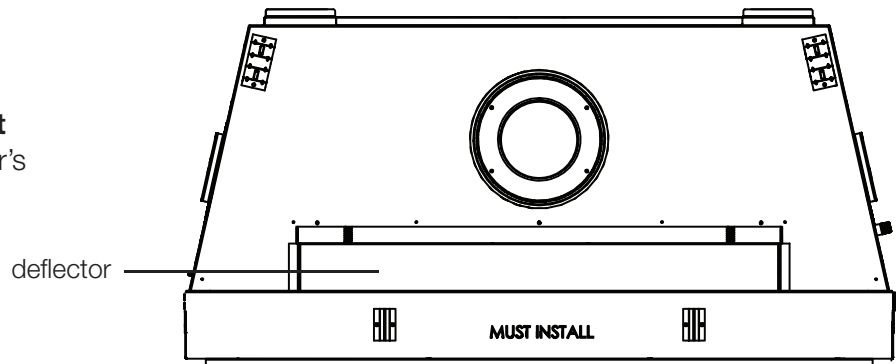

**top view**

# NAPOLEON CELEBRATING OVER 40 YEARS OF HOME COMFORT PRODUCTS



7200, Route Transcanadienne, Montréal, Québec H4T 1A3  
24 Napoleon Road, Barrie, Ontario, Canada L4M 0G8  
214 Bayview Drive, Barrie, Ontario, Canada L4N 4Y8  
103 Miller Drive, Crittenden, Kentucky, USA 41030  
De Riemsdijk 22, 4004 LC Tiel, The Netherlands

Phone: 1-866-820-8686  
[napoleon.com](http://napoleon.com)