

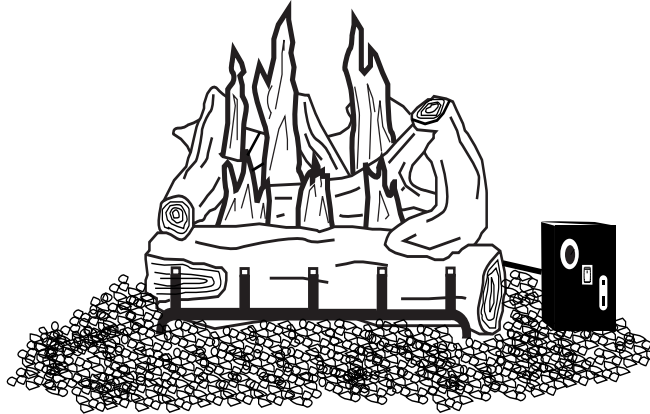


## Electronic Safety Pilot System for Vented Gas Logs

**Models:**  
**AFVK-SP**  
**AFVK-SP-HL**  
**AFVK-SP-MHL**

**IF YOU CANNOT READ OR UNDERSTAND THESE INSTALLATION INSTRUCTIONS DO NOT ATTEMPT TO INSTALL OR OPERATE**

## INSTALLATION AND OPERATING INSTRUCTION



This intermittent pilot ignition (IPI) gas valve (Safety Pilot) kit is set up for Natural gas only and designed to be used with 18 to 30-inch gas log sets (up to 120,000 Btu's). Optional LP conversions kits LPK-18 or LPK-24 are available.

**DUE TO HIGH TEMPERATURES THESE MODELS ARE NOT RECOMMENDED FOR INSTALLATION IN SEE THROUGH FIREPLACES**

**Warning:** Improper installation, adjustment, alteration, service or maintenance can cause injury or property damage. Refer to this manual for assistance or for additional information consult a qualified installer, service agency or gas supplier.

### FOR YOUR SAFETY

#### WHAT TO DO IF YOU SMELL GAS

- Do not try to light the appliance.
- Do not touch any electrical switch.
- Do not use any phone in your building.
- Immediately call your gas supplier from a neighbor's phone. Follow the gas suppliers instructions.
- If you cannot reach your gas supplier call the fire department.

**Young children should be carefully supervised when they are in same room as the appliance.**

**Important:** Read these instructions carefully before starting installation of your log set.

### FOR YOUR SAFETY

Do not store or use gasoline or other flammable vapors and liquids in the vicinity of this or any other appliance.

**Be sure Flue Damper and Glass Doors are fully open when operating any vented gas log set.**

### CALIFORNIA PROPOSITION 65



#### WARNING

This product is designed to operate with one of the following fuel sources: Liquid Propane or Natural Gas. The fuel used to operate this product, and the products of combustion of such fuel, can expose you to chemicals including Benzene which is known to the State of California to cause cancer, birth defects and other reproductive harm and Carbon Monoxide which is known to the State of California to cause birth defects or other reproductive harm.

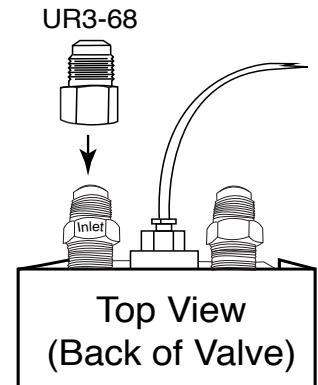
(For more information go to: [www.p65Warnings.ca.gov](http://www.p65Warnings.ca.gov).)

**Notice:** Please leave these instructions for the consumer. Retain for future reference

Table of Contents	
Description & Contents	Page 2
Valve Kit Models	Page 3
Installing into a Pre-Existing Log Set	Page 4
Installing with a New Log Set	Page 5
Reference Section & Wiring Diagram	Page 6
Battery Pack Preparation	Page 7
Gas Conversion	Page 8
Operation of System	Page 9-10
Troubleshooting	Page 11
Replacement Parts	Page 12
Warranty	Page 12

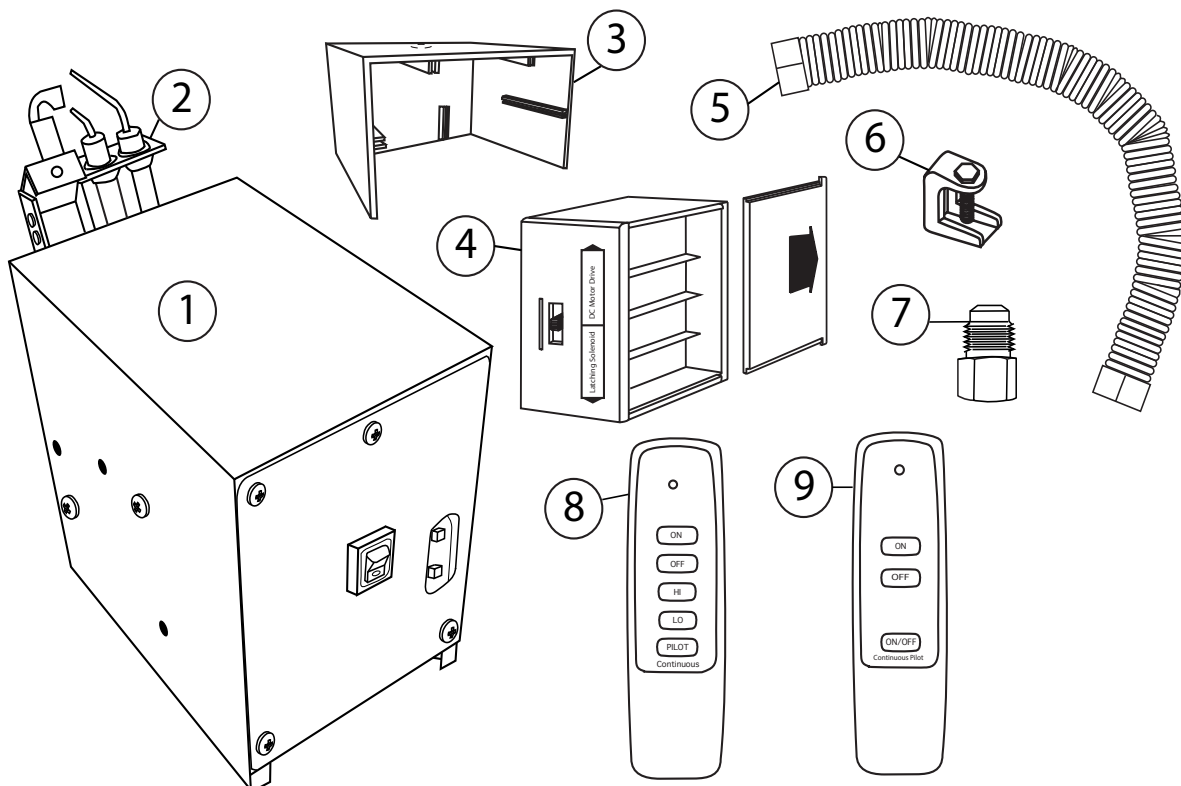
**INSTALLER:** Each valve kit is supplied with a (UR3-68) adapter that provides an option to convert the inlet or outlet gas connection from 3/8" flare fitting to a 1/2" flared fitting. Simply thread the UR3-68 on to the inlet/outlet gas flared fitting as shown in Fig. 1.

**Note:** No pipe joint compound or thread tape is necessary. Ensure fittings are tight and test for gas leaks.

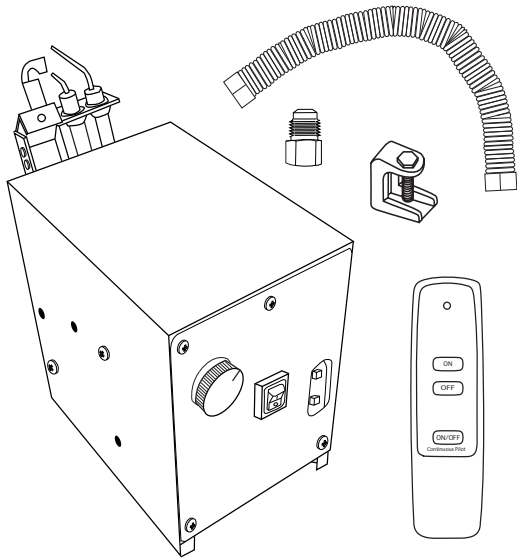


**Fig. 1** Installing UR3-68 to the inlet or outlet side of gas valve

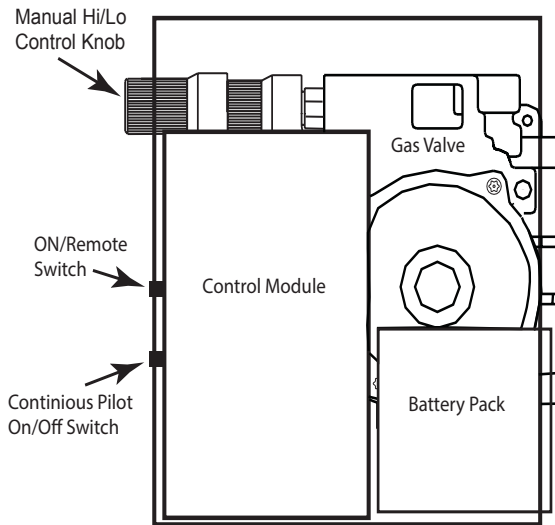
**DESCRIPTION:** This installation manual covers three valve kits; AFVK-SP, AFVK-SP-HL and AFVK-SP-MHL. Installation is the same for all of the kits however the operation is slightly different. All valve kits are fire tested at the factory to ensure proper operation. Each kit is supplied with a individual rocker switch to enable ON/OFF operation without the transmitter (if needed) and the ability to have continuous pilot or intermittent pilot ignition (IPI), which only operates the pilot when the log set is turned ON. See each kit below and their contents.



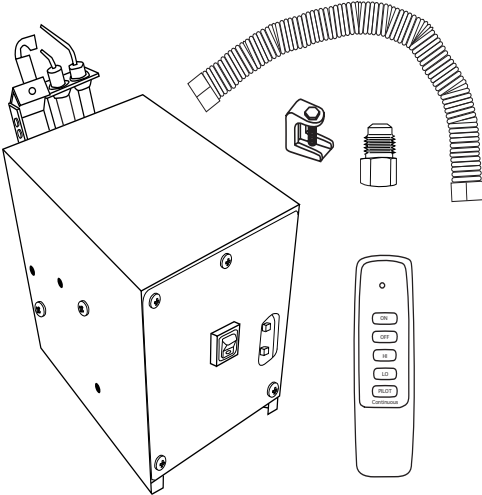
**Fig. 2** Carton contents: 1- Valve Kit 2- Pilot Assembly 3- Battery Pack Heat Shield 4- Battery Pack 5- Flex Connector 6- Damper Clamp 7- Adapter Fitting 8- SP1001HL 9- SP1001



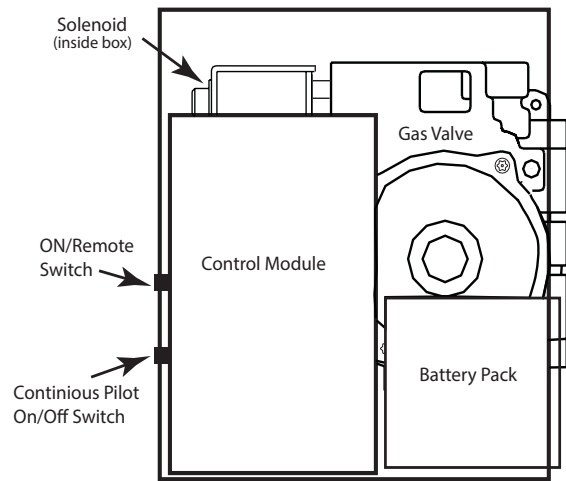
**Fig. 3** AFVK-SP: Manual Hi/Lo knob, SP1001 transmitter, damper clamp, flex line, adapter fitting (includes battery pack heat shield & batteries not shown).



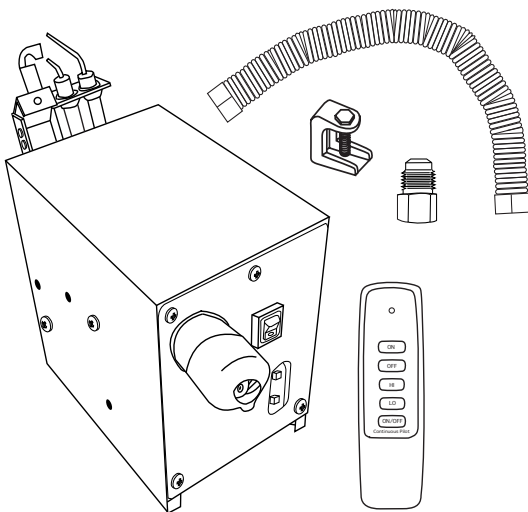
**Fig. 6** Shows side view of component parts inside the AFVK-SP valve kit.



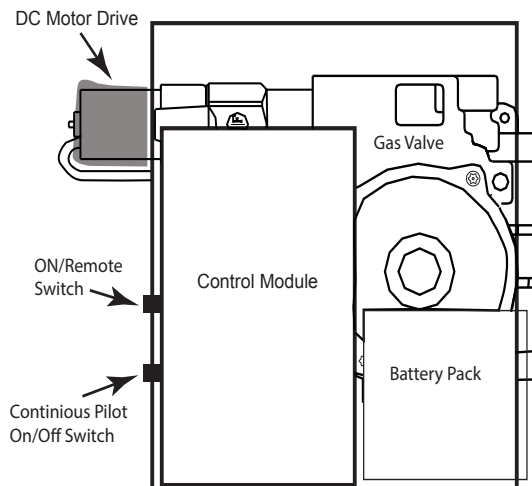
**Fig. 4** AFVK-SP-HL: Hi/Lo Solenoid, SP1001HL transmitter, damper clamp, flex line, adapter fitting ((includes battery pack heat shield & batteries not shown).



**Fig. 7** Shows side view of component parts inside the AFVK-SP-HL valve kit.



**Fig. 5** AFVK-SP-MHL: Hi/Lo DC Motor Drive, SP1001HL transmitter, damper clamp, flex line, adapter fitting (includes battery pack heat shield & batteries not shown).



**Fig. 8** Shows side view of component parts inside the AFVK-SP-MHL valve kit.

## INSTALLATION PRECAUTIONS

These instructions must be used as a supplement to the instructions supplied with the gas log set. Follow the gas log instructions supplied by the manufacturer on the placement of the burner pan, log basket grate, burner media (sand or vermiculite), ember material and the log placement. Please follow these instructions on the connection of the inlet line to the gas valve and to the burner pan assembly. If this fireplace installation has glass doors, only operate the fireplace with glass doors in the fully open position.

This electronic safety pilot system contains a valve, pilot assembly, module and connector that are certified by CSA under file report number 224930.

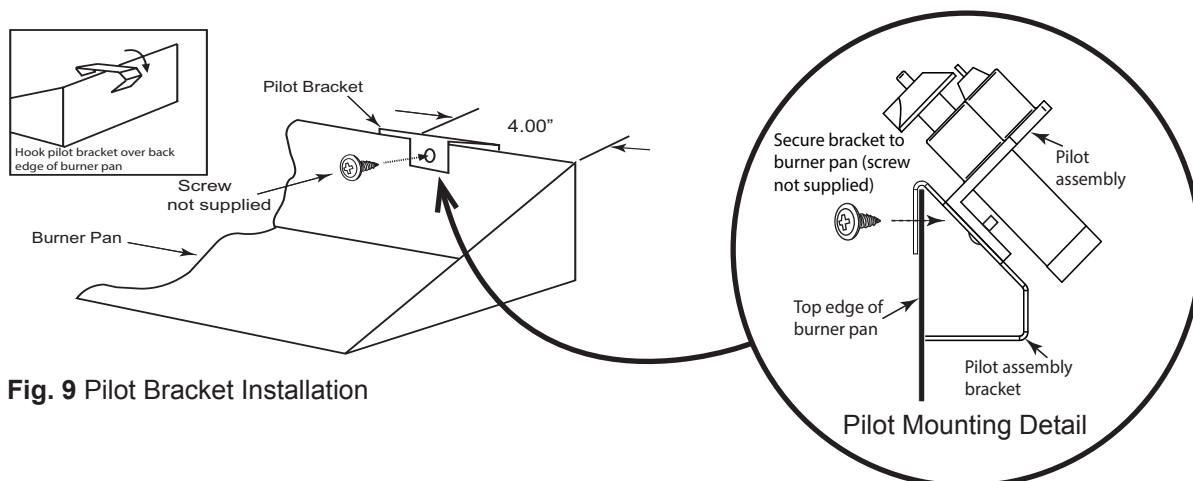
**NOTE: VALVE BOX MUST BE LOCATED A MINIMUM OF 2-INCHES FROM SIDES OF BASKET GRATE AND NEVER PLACED DIRECTLY IN FRONT OR BEHIND THE BASKET GRATE.**

## Installation Instructions:

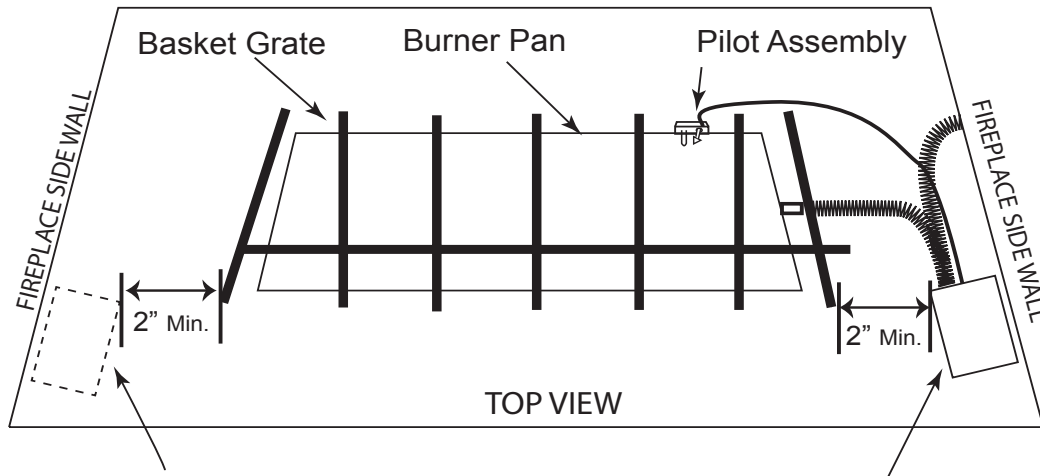
### INSTALLATION: VALVE KIT WITH PRE-INSTALLED LOG SET:

1. Make sure gas is completely turned OFF to the gas log set. Make sure you have a certified and approved shut-off within 6-feet of the fireplace, or per the local code requirements.
2. Remove all logs and basket grate and set aside.
3. Disconnect the 3/8" flared fitting on the existing manual valve from the inlet gas supply.
4. Remove existing manual valve and fittings on the burner pan.
5. Locate a position for the pilot assembly on the back of the burner pan about 4-inches from the right or left side of the burner pan (See Fig 9).
6. Mount pilot assembly to burner pan as shown in (Fig. 9). **Note:** This pilot bracket clips on the top edge of burner pan and holds the pilot at a 45° position onto the pan, an attachment screw is recommended. Bend pilot tubing from pilot assembly until the bottom of the pilot bracket is resting against the pan. This will hold the pilot at the 45° position. (Use caution when bending pilot tubing not to kink the tubing and when locating the igniter and flame sensor wires not to locate the wires and the tubing in or over the burner pan.)
7. Locate the valve kit in the right or left front corner of the firebox as far forward as possible (See Fig. 10).
8. Bend inlet gas supply line and connect the 3/8" flare fitting to 3/8" inlet fitting on the gas valve. (Use caution not to kink the aluminum inlet line when bending to fit to the valve). **Note:** Use the UR3-68 adapter (if needed) for inlet or outlet gas supply.
9. Bend 12" stainless flex line and connect it to the valve **outlet**, then connect other end to 3/8" flare fitting to existing burner pan. **Caution:** Ensure no gas line, inlet or outlet, are placed over top of the burner pan.
10. Turn ON gas supply and check all connections for leaks using soapy water solution.
11. Follow valve lighting instructions. After the pilot is operating, check pilot fittings for leaks.
12. Reinstall basket grate and logs.
13. Install Damper clamp (supplied with valve kit) which allows damper to remain slightly open to allow the pilot gases to vent).

**NOTE: For any PROPANE installations see conversion kit instructions.**



**Fig. 9** Pilot Bracket Installation



**Optional Valve Box Location**                      **Valve Box Location**

**Fig. 10** Basic installation layout centering the grate and components inside the firebox.

**INSTALLATION: VALVE KIT WITH NEW LOG SET:**

1. Make sure gas is completely turned OFF to the fireplace. Make sure you have a certified and approved shut-off within 6-feet of the fireplace, or per the local code requirements.
2. Follow the instructions supplied with the log set to locate the burner pan. Using the fittings, orifice and gas supply line that came with the log set. Connect the line to the inlet gas supply.
3. Locate a position on the back of the burner pan to mount the pilot assembly about 4" from the right or left side of the burner pan (See Fig. 9).
4. Mount pilot assembly to burner pan as shown in (Fig. 9). **Note:** This pilot bracket clips on the top edge of the burner pan and holds the pilot at a 45° position onto the pan, an attachment screw is recommended. Bend pilot tubing from pilot assembly until the bottom of the pilot bracket is resting against the pan. This will hold the pilot at the 45° position. (Use caution when bending pilot tubing not to kink the tubing and when locating the igniter and flame sensor wires not to locate the wires and the tubing in or over the burner pan.) Locate the valve kit in the right or left front corner of the firebox as far forward as possible (See Fig. 10)
5. Bend inlet gas supply line and connect to the 3/8" flare fitting to 3/8" inlet connector on the valve kit (Use caution not to kink the aluminum inlet line when bending to fit to the valve).
6. Bend 12" stainless flex line and connect to valve outlet. Connect other end to 3/8" flare fitting on burner pan.  
**Caution:** Ensure no gas line, inlet or outlet, are placed over top of the burner pan.
7. Turn ON gas supply and check all connections for leaks using soapy water solution.
8. Follow valve lighting instructions. After pilot is operating check pilot fittings for leaks.
9. Follow the instructions supplied with the log set to install ember material, basket grate and logs.
10. Install Damper clamp (supplied with valve kit) which allows damper to remain slightly open to allow the pilot gases to vent).

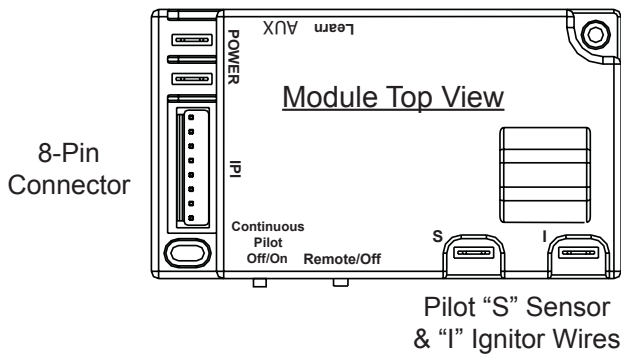
**NOTE: For any PROPANE installations see conversion kit instructions.**

**THIS SECTION IS FOR REFERENCE ONLY**

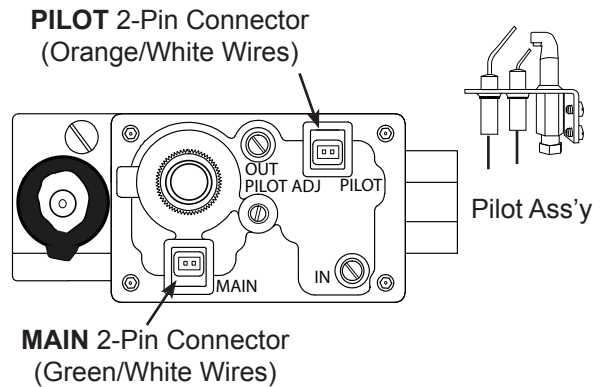
The pilot tubing and wiring, electronic module and battery pack come pre-assembled in the valve box.

**WIRING FROM THE PILOT ASSEMBLY**

1. The "S" (Sensor) and "I" (Ignitor) wires from the pilot assembly are connected at the factory to the "S" & "I" terminals on the electronic module. **NOTE:** The terminal locations in Fig. 11.
2. Route the "S" & "I" wires from the pilot assembly to an area that will be away from the pilot or main burner flame and at least 2-inches from the burner pan.

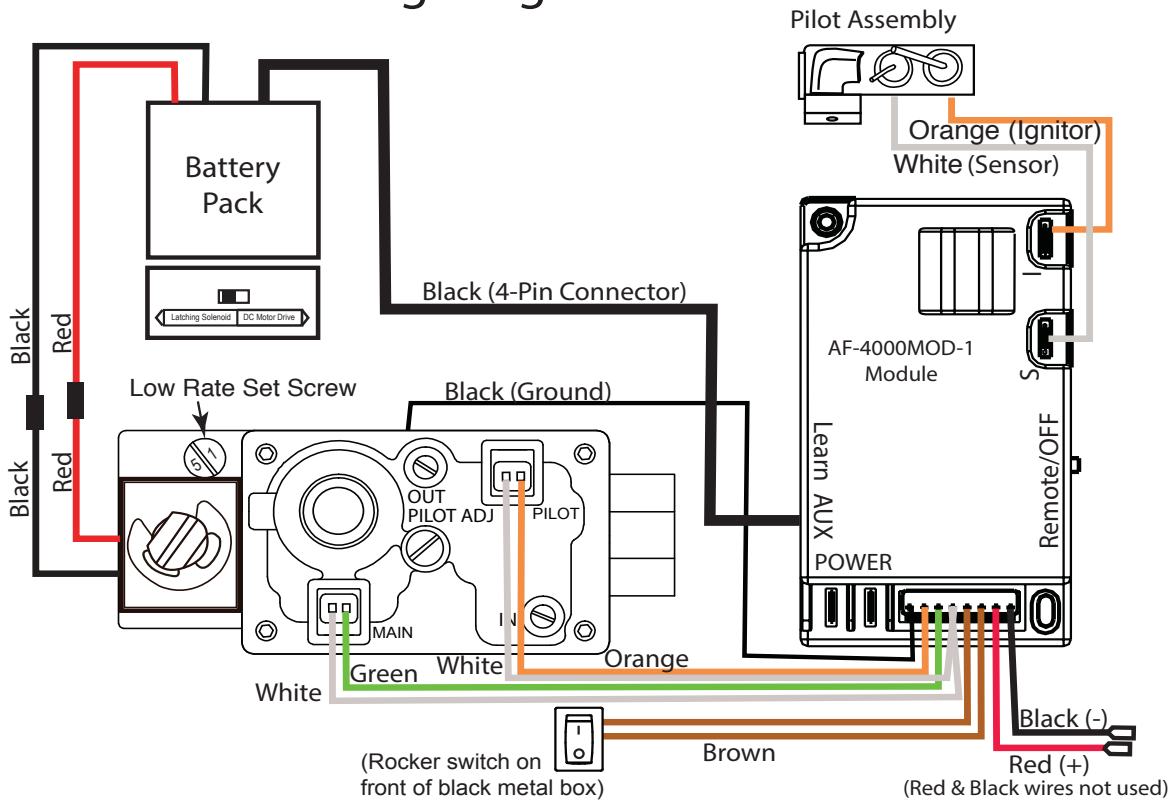


**Fig. 11** Module Identification



**Fig.12** Gas Valve Identification

**Valve Kit Wiring Diagram**



**Fig. 13** Wiring diagram shows a valve kit with a solenoid attached to the gas valve. If a DC motor drive is attached the same red/black wires would apply. **Note:** Switch on battery pack must be on DC Motor Drive position for AFVK-SP-MHL model or Latching Solenoid position for AFVK-SP model.

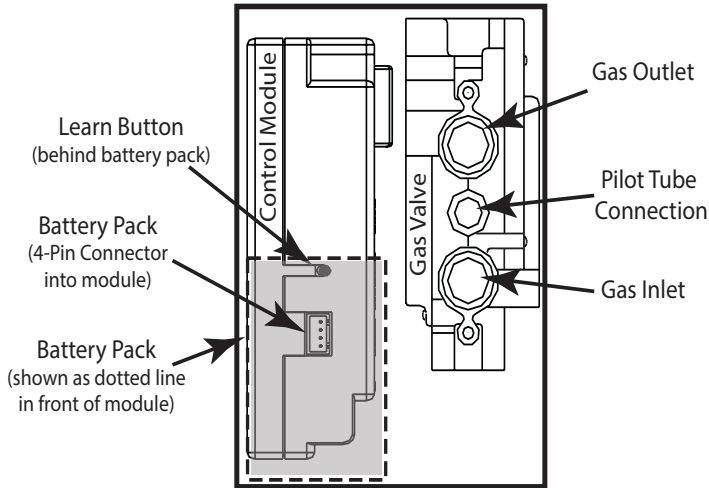


## INSTALLING BATTERIES INTO THE VALVE KIT BATTERY PACK

The battery pack is located at the back of the valve kit inside the metal box with the heat shield. See Fig. 14.

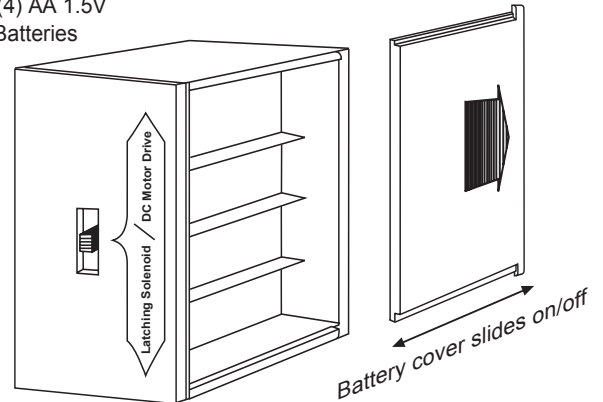
1. The valve kits battery pack has a 6-inch, 4-pin wire harness connecting the battery pack to the module. See Fig. 16.
2. Prior to installation remove the battery pack during installation and install (4) AA batteries.
3. Install the heat shield ovetop of the battery pack and slide it back into the back of the valve box. See Fig. 14.

**Note:** All valve kits are battery powered systems and will not operate without the battery pack. The battery pack controls the solenoid or motor drive in the system and provides the power necessary to operate each valve kit.



**Fig. 14** Battery pack location.

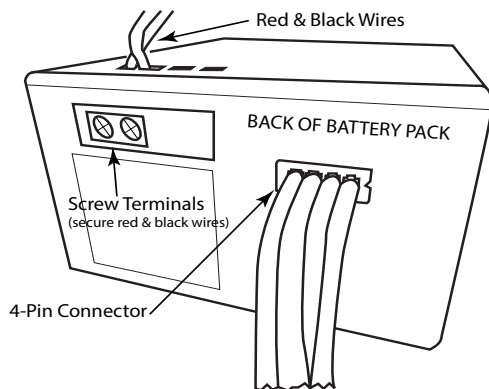
Requires (4) AA 1.5V  
Alkaline Batteries



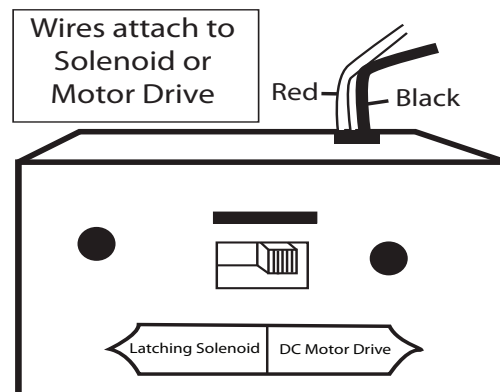
**Fig. 15** Install (4) AA batteries into the battery pack.

**AFVK-SP, AFVK-SP-HL, & AFVK-SP-MHL MODELS:** The battery pack is located at the back of the valve kit inside the metal box with the heat shield. See Fig. 14. Install (4) AA alkaline batteries in the battery pack as shown in Fig. 15.

1. The 6-inch, 4-pin male connector on the battery pack comes pre-installed to the 4-pin female connector located on the battery pack and module. **Note:** Figs. 14 & 16 for reference.
2. The AFVK-SP-HL & AFVK-SP-MHL also has (2) 18" wires (Red & Black) that are connected to the Hi/ Lo solenoid. Reference Figs. 11, 16 & 17.
3. After the valve kit installation process is completed reinstall heat shield and battery pack back into the rear area of the metal box as shown in Fig. 14.
4. Ensure the excess wire from the 4-pin wire harness and Hi/Lo wire harness are tucked in the metal box to protect them from heat.



**Fig. 16** 4-pin connector on back of battery pack.



**Fig. 17** Red & Black wires out of battery pack.

### **AFVK-SP-HL & AFVK-SP-MHL MODELS ONLY**

The battery pack is located at the back of the valve kit inside the metal box with the heat shield. See Fig. 14. Prior to installation remove the battery pack during installation and install (4) AA batteries.

1. Check the connections of the stripped ends of the RED and BLACK wires on solenoid wiring harness to the screw terminals located on the top of the battery pack (See Fig.16).
2. Connect the (2) 1/4" female terminals (red & black wires) on the solenoid or DC Motor Drive wiring harness to the matching color (red & black wires ) 1/4" male terminals on the wires from the Hi/Lo solenoid or DC Motor Drive. See Figs. 13 (page 6) & 16-17 (page 7).
3. After the valve kit installation process is completed reinstall hear shield and battery pack back into the rear area of the metal box as shown in Fig. 14.

**Note:** Verify the AFVK-SP-HL the battery pack switch is set to **LATCHING SOLENOID** power to operate the HI/LO solenoid. This switch is located on the face of the battery pack in Figs. 13 & 17.

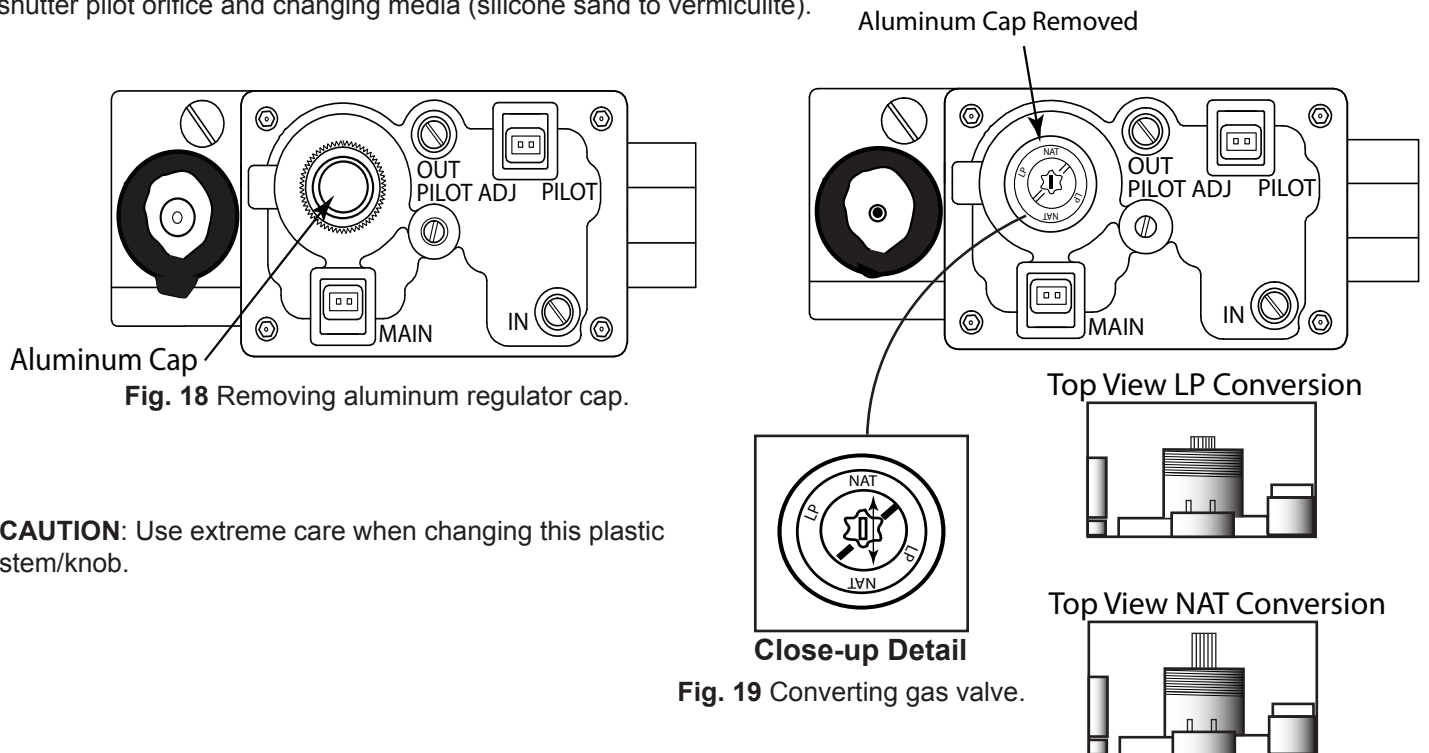
**Note:** Verify the AFVK-SP-MHL the battery pack switch is set to **DC MOTOR DRIVE** power to operate the HI/LO DC Motor Drive. This switch is located on the face of the battery pack in Figs. 13 & 17.

### **CONVERTING THE AFVK-SP, AFVK-SP-HL, & AFVK SP-MHL FROM NATURAL TO PROPANE GAS**

Note: When converting a vented log set from NATURAL to PROPANE it will be necessary to use the LPK-18 or LPK-24

1. The AFVK-SP, AFVK-SP-HL, or AFVK-SP-MHL electronic control valves are convertible from Natural gas to Propane gas by simply turning the stem/knob located on the front (Face) of the gas valve. See Fig. 18.
2. Remove the black metal face plate/cover from the valve box to access the face of the gas valve.
3. Unscrew the aluminum cap on the front of the gas valve. Note the position of the marker on the end of the stem. This mark will point to NAT or LP that indicates the type of gas the valve is set on.
4. To convert the AF-4000 from the factory setting (NAT) push the stem inward and turn the stem 90°. The marker will now point to LP and the stem will remain inward. See Fig. 19.
5. To convert the AF-4000 back to the factory setting push the stem inward and rotate 90°. The marker will now point to NAT and the shaft will stay out. See Fig. 19.
6. After the conversion has been made check the outlet pressure with a manometer. The factory setting on the internal regulator is 3.5"WC natural and 10.5"WC propane. Pressure taps are located on front of the gas valve labeled IN and OUT.
7. Replace the aluminum cap.

Note: See the LPK 18 or 24 instructions to convert the burner pan to propane gas this involves installing an orifice air shutter pilot orifice and changing media (silicone sand to vermiculite).



**CAUTION:** Use extreme care when changing this plastic stem/knob.



## OPERATION FEATURES

Special Features of the valve kits control module

All valve kits modules have (2) special features built into the system as follows:

### **1. CONTINUOUS PILOT FEATURE:**

The AFVK-SP, AFVK-SP-HL & AFVK-SP-MHL valve kits have a continuous pilot feature that may be activated in cold climate conditions or to maintain a draft in the chimney. The continuous pilot can be activated by the following two methods.

#### **1.Switch on the Front Valve Kit**

The Continuous Pilot feature may be activated by placing the "Off/Continuous Pilot" switch located on the front of the valve kit in the "Continuous Pilot" position. See Fig. 20. When this switch is turned to the Continuous pilot position the pilot will immediately begin sparking to light the pilot and the pilot will remain ON.

#### **2.Button on the Hand Held Remote**

To use the continuous pilot feature from the hand held remote control ensure the "Off/Remote" switch on the front of the valve kit is in the "remote" position. See Fig. 20. Simply press the button on the hand held remote marked "Continuous Pilot" (See Fig. 21). The pilot will immediately begin sparking to light the pilot and the pilot will remain ON.

#### **Note: 7-Day On-Demand Pilot**

When the control module is set in the Continuous Pilot mode (either manually or by remote control), a 7-day countdown timer will be started. After 7-days if the main flame has not been turned ON, the control module will turn the pilot OFF. If the main flame is turned ON during the 7-day countdown, the timer is reset and the cycle restarted again.

### **2. REMOTE CONTROL FEATURE:**

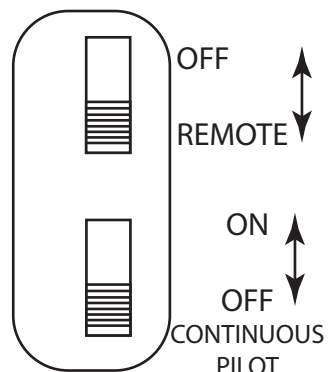
The AFVK-SP, AFVK-SP-HL, or AFVK-SP-MHL comes with a remote control transmitter. This remote is already programmed to operate your valve kit directly out of the box.

The valve kit module has a built in remote control receiver that allows the user to program a hand held remote transmitter to the appliance at any time during or after installation of the appliance.

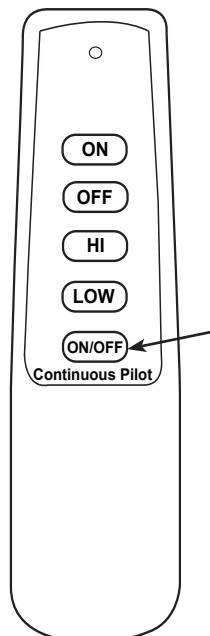
1. There is a switch located on the front of the valve kit face plate that reads OFF/REMOTE. See Fig. 20.
2. When the OFF/REMOTE switch is in the OFF position the valve kit will operate from the rocker switch in the center of the face plate. **Note:** Fig. 13 page 6 ("O" is Off and "I" is for Ignite)
3. When the OFF/REMOTE switch is in the REMOTE position the appliance will operate from the Remote Control transmitter. **Note:** The valve kit module must be programmed to the Remote Control transmitter.
4. If needed, program the module (Make sure the batteries have been installed in the battery pack). Locate the learn button on the module (See Fig. 14). Press and release the learn button there will be a beep sound from the module. Then press any button on the remote transmitter. Once the modules internal receiver accepts the transmitter code, there will be a series of rapid beeps.
5. The remote system is ready for use.

### **MAINTENANCE OF YOUR AFVK-SP SERIES VALVE KIT SYSTEM**

1. Your system should be checked once a year (At the start of the heating season) for proper operation by a qualified service representative.
2. Replace all batteries at the start of the season. Items to check: electronic valve operation, Spark to pilot operation, ON/OFF switch operation, damper operation, visual check of the burner and gas connections for leaks.



**Fig. 20** Valve box switches



**Fig. 21** Remote control Continuous button

## **FOR YOUR SAFETY READ BEFORE LIGHTING**

**WARNING: IF YOU DO NOT FOLLOW THESE INSTRUCTIONS EXACTLY, A FIRE OR EXPLOSION MAY RESULT CAUSING PROPERTY DAMAGE, PERSONAL INJURY OR LOSS OF LIFE.**

1. This installation should be installed with provisions for combustion and ventilation air, must conform with local codes or in the absence of local codes to the national fuel Gas Code ANSI Z223 latest addition.
2. This product must be on a gas supply line that is less than 1/2 psi. and an individual manual shut-off.
3. Never operate this new system with the glass fireplace enclosures (doors) in the closed position.
4. Connecting 120-volt electrical power to a valve kit directly will cause damage and will void warranty. An optional AF-4000ADP24 adapter (step-down transformer 120VAC to 7.5VDC) can be installed to eliminate batteries. The battery pack must remain connected to enable the solenoid or motor drive operation however the batteries can be removed.

**NOTE: VALVE BOX MUST BE LOCATED A MINIMUM OF 2-INCHES FROM SIDES OF THE BASKET GRATE AND NEVER PLACED DIRECTLY IN FRONT OR BEHIND THE BASKET GRATE**

### **OPERATING PROCEDURE**

After installation is completed follow these steps to operate the AFVK-SP.

1. Turn ON the main gas supply and check all fittings and connections for leaks with soap and water solution.
2. Move the OFF/REMOTE slide switch on the face plate of valve box to the REMOTE position. See Fig. 20. Push the **ON** button on the remote transmitter this will start the ignition system. The pilot will begin to spark and then light. Once the pilot is lit 2 seconds the main burner will light.
3. Adjust the main flame from **HI** to **LO** with the manual HI/LO knob on front of valve kit.

**Note:** Move the OFF/REMOTE slide switch on the face plate of valve box to the OFF position then push the rocker switch to the "I" position this will manually start the ignition system. Once the pilot is lit 2 seconds the main burner will light.

After the installation is complete follow these steps to operate the AFVK-SP-HL & AFVK-SP-MHL

1. Turn on the main gas supply and check all fittings and connections for leaks with soap and water solution.
2. Move the OFF/REMOTE slide switch on the front to the REMOTE position. See Fig. 12. Push the ON button on the remote transmitter position this will start the ignition system. The pilot will begin to spark and then light once the pilot is lit 2 seconds later the main burner will light.
3. Adjust the main flame from HI to LO with the HI/LO buttons on the remote transmitter.

**Note:** Move the OFF/REMOTE slide switch on the face plate of the valve box to the OFF position then push the rocker switch to the "I" position this will manually start the ignition system. Once the pilot is lit 2 seconds the main burner will light.

**Note:** On the AFVK-SP-H/L press and release the LO button and the flame will go to LO. Press and release the HI button and the flame will go to HI.

**Note:** On the AFVK-SP-MH/L press and hold the LO button and the flame will modulate to LO. Press and hold the HI button and the flame will modulate to HI.

**Note:** On initial start up: due to air in the gas supply line it may take an extended amount of time for the pilot to light. There is a 60 second lockout built into the module. To reset turn the rocker switch OFF then ON or push the OFF button on the remote transmitter then push the ON button.

## **TROUBLESHOOTING**

**IMPORTANT:** An experienced qualified service technician should only perform troubleshooting procedures.

### **PILOT WILL NOT STAY LIT:**

1. Confirm that the “S” sensor wire and the “I” igniter wires are properly connected to the module “S” and “I” terminals on the module. **Note:** Figs. 11 & 13 on page 6 for terminal locations.
2. Confirm that the Spark to Pilot burner is properly grounded to the gas control valve (Ground is provided through the pilot tubing).
3. Check the ground wire from the module to the gas control valve (Black ground wire on the 8 pin connector)
4. Check the power source battery pack connections and voltage of batteries.
5. Optional check the position of the CONTINUOUS PILOT switch on the valve kit module. See: Fig. 20

### **CONTINUOUS PILOT SHUTS OFF AFTER A PERIOD OF TIME**

1. If the control module is set in the Continuous Pilot mode (either manually or by remote control), a 7-day countdown timer will be started. After 7-days if the main flame has not been turned ON, the control module will turn the pilot OFF. If the main flame is turned ON during the 7-day countdown, the timer is reset and the cycle restarted again.
2. When continuous pilot is turned OFF, simply press the ON button on the remote control or press the rocker switch to ON to light the system in a normal fashion. The 7-day timer will reset unless you turn the continuous pilot switch to the OFF position.

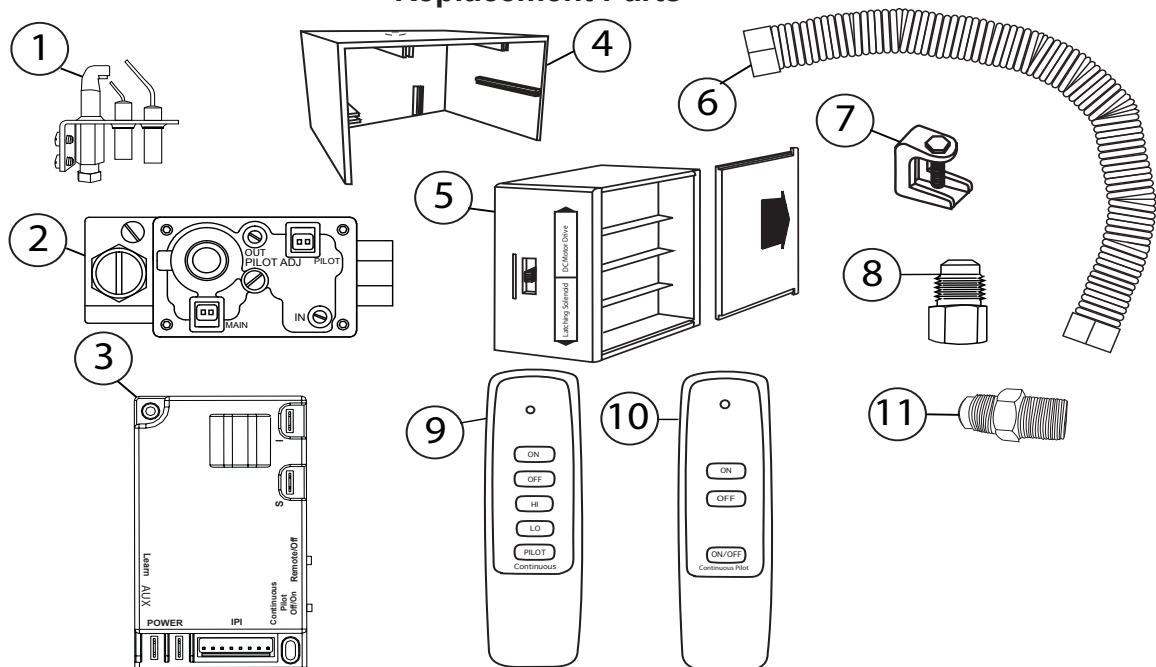
### **MAIN BURNER DOES NOT COME ON WHEN THE MANUAL ROCKER SWITCH OR REMOTE CONTROL IS TURNED ON:**

1. Confirm that the pilot sparks and lights.
2. Check the (2) pin plastic connectors that plug in the face of the gas control valve. See Fig. 13.
3. Confirm that the gas control valve is properly grounded to the valve kit module.

### **REMOTE WON'T OPERATE VALVE KIT**

1. Ensure the module switch is in Remote position and check batteries in the remote and the battery pack.
2. **Clear Codes:** Memory in the module might be full if the learn button is pressed too many times. If this happens no audible beep will be heard. To clear memory, place the module slide switch into the REMOTE position. Press the learn button and release after 10 seconds. You should hear three (3) long audible beeps indicating all codes have cleared. You can now “relearn” the transmitter to the module as described below.
3. Press the LEARN button on the module to accept the transmitter security code. Ensure the slide button on the module in the REMOTE position; the module will not LEARN if the slide switch is in the OFF position. The LEARN button is located on the side of the module (See figure 10). Using the end of a paperclip or toothpick gently press and release the black LEARN button inside the hole. When you release the LEARN button the module will emit an audible “beep”. After the module emits a beep press the transmitter ON button and release. The module will emit several beeps indicating that the transmitter’s code has been accepted into the module then you can presume normal operation.

## Replacement Parts



Item #	Description	Part #
1	Complete Pilot Assembly	238577-13
2	Gas Valve Only for AFVK-SP	AF-4014
2a	Gas Valve Only for AFVL-SP-HL	AF-4024
2b	Gas Valve Only for AFVK-SP-MHL	AF-4034
3	Control Module	AF-4000MOD-1
4	Battery Pack Heat Shield	RS-1A
5	Battery Pack	AF-4000BP
6	10" Flex Gas Line	T102-9898-10
7	Damper Clamp	685-14
8	3/8" to 1/2" flared adapter	UR3-68
9	Remote control used on AFVL-SP-HL & AFVK-SP-MHL	SP1001H-LTX
10	Remote control used on AFVK-SP	SP1001-TX
11	3/8" Flare x 3/9" NPT Connector	U1-6C-S
12	8-Pin wire harness for all valve kits (not shown)	AF-40008PIN6WH
13	1-inch Manual Extension Knob for AFVK-SP (not shown)	AF-2000H-L-1

### LIMITED WARRANTY

American Flame warrants the AFVK-SP, AFVK-SP-HL, or AFVK-SP-MHL Valve Kit for 12 months from the date of purchase or installation to the original purchaser to be free from defects in materials and workmanship. Damage to the AFVK-SP, AFVK-SP-HL, or AFVK-SP-MHL Valve Kit caused by accident, misuse, abuse, or installation error, whether performed by a contractor, Service Company, or owner, is not covered by this warranty. American Flame will not be responsible for labor charges and/or damage incurred in installation, repair, replacement, or for incidental or consequential damage. Some states, provinces, and nations do not allow exclusion or limitations of incidental or consequential damages, so the above limitations or exclusions may not apply. This warranty gives you specific legal rights. You may also have other rights that vary by state, province, or nation.

**FOR TECHNICAL QUESTIONS, CALL: (855) 498-8324**

Support Sales: (888) 699-6167  
[www.skytechpg.com](http://www.skytechpg.com)  
 9230 Conservation Way, Fort Wayne, IN 46809

