



Model: 5301

INSTALLATION AND OPERATING INSTRUCTIONS

IF YOU CANNOT READ OR UNDERSTAND THESE INSTALLATION INSTRUCTIONS DO NOT ATTEMPT TO INSTALL OR OPERATE

INTRODUCTION

This SKYTECH remote control system was developed to provide a safe, reliable, and user-friendly remote control system for gas heating appliances. The system can be operated thermostatically or manually from the transmitter. The system operates on radio frequencies (RF) within a 20-foot range using non-directional signals. The system operates one of 1,048,576 security codes that are programmed into the transmitter at the factory; the remote receiver's code must be matched to that of the transmitter prior to initial use. This is a dry contact switch designed for millivolt systems.

Review **COMMUNICATION SAFETY SECTION** under **TRANSMITTER** section and **THERMO SAFETY SECTION** under **REMOTE RECEIVER** section. These signal/temperature safety features shut down the fireplace system when a potentially unsafe condition exists.

NOTE: This product is designed for use with an attended hearth appliance or fire feature. Adults must be present when the Control System is operating. DO NOT program or thermostatically set this Control to operate a hearth appliance or fire feature when Adults are not physically present. Furthermore, DO NOT leave the hearth appliance or fire feature burning unattended; it may cause damage or serious injury. If an Adult is going to be away from the hearth appliance or fire feature for any length of time, then the handheld/wall mount, receiver/control module and application should be in the "OFF" position.

TRANSMITTER

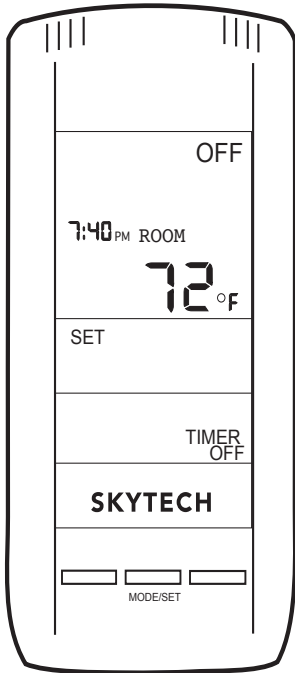

FRONT

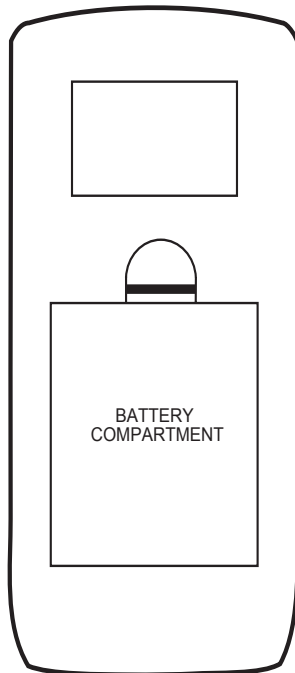

BACK

The transmitter operates on (4) AAA-size 1.5V batteries. It is recommended that ALKALINE batteries always be used for **longer battery life and maximum operational performance**. **IMPORTANT:** New or fully charged batteries are essential for proper operation of the multi-function transmitter. Insert (4) AAA size 1.5 V batteries into the battery compartment on the back of the transmitter, positioning the (+) and (-) ends of the batteries as indicated on the casing. When the batteries are inserted, the screen at right (with similar numbers) will display.



Note: On initial start up if a LOW battery icon appears on the screen, check the position of the batteries.

Note: Due to the sensitive temperature-monitoring components in the transmitter, it may be necessary to allow the transmitter to stabilize to room temperature before accurate room temperatures are displayed on the screen. If the transmitter is activated from a severe cold condition, it can take up to 15-minutes for accurate temperature readings to appear.

LCD DISPLAY SCREEN

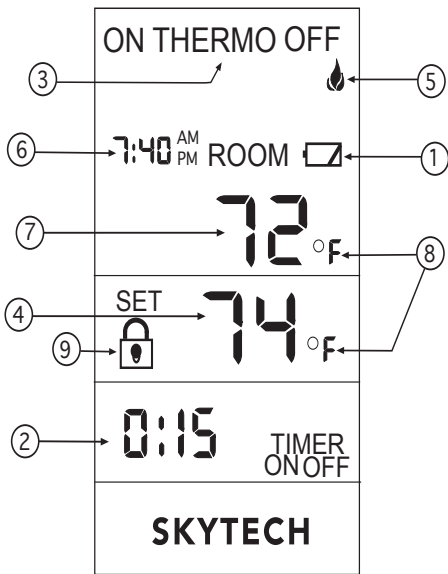

1. **BATTERY ICON** - Battery power is low. Replace batteries within two weeks.
2. **TIMER**- Indicates time remaining before system shuts off, when timer-programmed; 9-hour maximum setting.
3. **MODE**- Indicates operation MODE of system. ON indicates the system is ON, either manually or thermostatically. OFF indicates the entire system is turned OFF THERMO indicates the system will automatically cycle ON/OFF, depending on programmed
4. **SET**- Indicates desire SET room temperature for THERMO operation
5. **FLAME** – Indicates burner/valve in operation.
6. **CLOCK** – Indicates the current time in AM/PM
7. **ROOM** – Indicates CURRENT room temperature.
8. ° F indicates degrees Fahrenheit (°C indicates degrees Celsius).
9. **LOCK** – Child lock out.

OPERATION FUNCTIONS

Note: Touch anyplace on the screen and the screens blue back light will light up and stay on 5-seconds. To operate the system, press the MODE/SET button or press the MODE SECTION on the LCD screen on the front of the transmitter to select the operational MODE desired.

- ON indicates the system is ON, either manually, timed or thermostatically.
- THERMO indicates the system will automatically cycle ON/OFF, depending on programmed set temperature.
- OFF indicates the entire system is turned OFF.

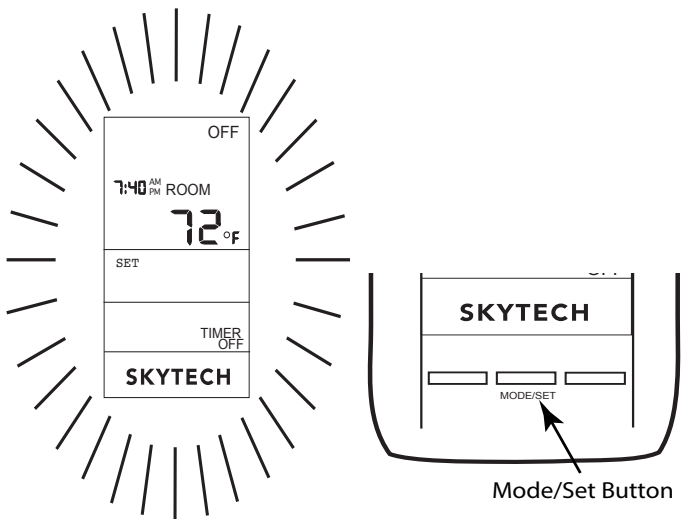

SETTING THE CLOCK

NOTE: When setting the clock the transmitter must be in the OFF position

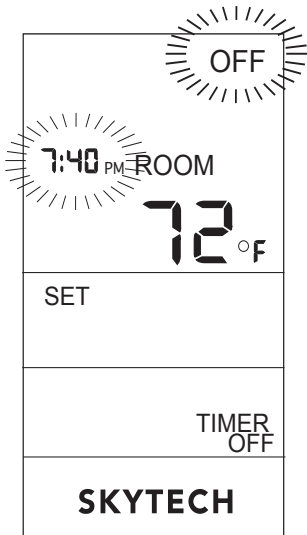

1. Press the word TIMER on the LCD screen of the transmitter for more than two seconds. The hour digit(s) will begin flashing.
2. Press the UP or DOWN buttons until the desired hour is displayed in AM or PM.
3. After setting the desired hour, press and release the word TIMER again and the minutes digits will begin flashing.
4. Press the UP or DOWN buttons until the desired minutes are displayed.
5. Press the word TIMER again for more than two seconds then release. The minute digits will cease flashing, indicating the clock has been successfully set.

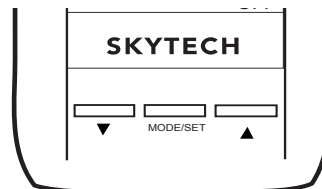

NOTE: Flashing numbers on the display indicate the system is awaiting user input, such as using the UP and DOWN buttons to program a new setting. If no change is made to flashing digits within 15 seconds, the system will complete the procedure last programmed and reset the display to its normal state.

SETTING °F/°C SCALE

The factory setting for temperature is °F. To change this setting to °C, first press and hold the UP button and the DOWN button on the transmitter at the same time. Follow this same procedure to change from °C back to °F. When changing between the °F and °C scales, the temperature in the SET frame defaults to the lowest temperature (45°F, or 6°C). The highest SET temperature is 99° Fahrenheit (32° Celsius).

SETTING DESIRED ROOM TEMPERATURE

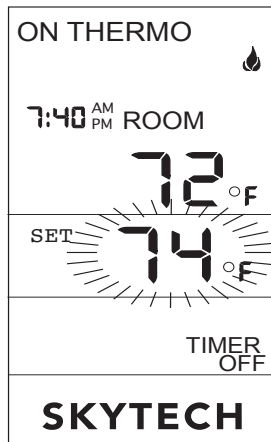

This remote control system can be thermostatically controlled when the transmitter is in the THERMO mode (**THERMO must be displayed on the screen**). To set the DESIRED room temperature, press the MODE/SET button to place the transmitter into THERMO mode, then press the UP or DOWN button to select the desired room temperature. The highest SET temperature is 99° Fahrenheit (32° Celsius).

OPERATIONAL NOTE: TO CONSERVE BATTERY POWER, CHANGES IN ROOM TEMPERATURE ARE AUTOMATICALLY UPDATED EVERY TWO MINUTES TO THE TRANSMITTER.

SETTING THE TEMPERATURE SWING (TEMPERATURE DIFFERENTIAL)

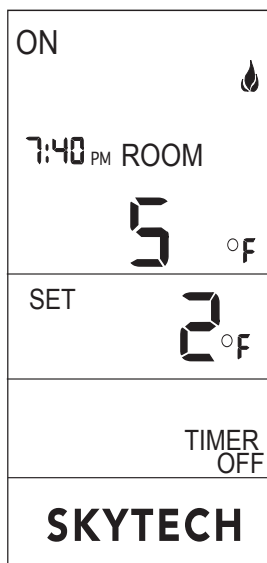

The Thermo Mode on the transmitter operates the appliance whenever the ROOM TEMPERATURE varies a certain number of degrees from the SET TEMPERATURE. This variation is called the "SWING" or TEMPERATURE DIFFERENTIAL.

1. To change the temperature "SWING" setting (1°-3°), press the TIMER and DOWN buttons simultaneously to display the current "SWING" setting in the SET TEMP frame. The letter "S" will display in the ROOM TEMP frame on the LCD screen.
2. Press the UP or DOWN button to change the temperature differential or "SWING" (1°-3°).
3. To store the "swing number" press the MODE/SET button or allow 15 seconds to lapse, and the new "swing number" will be automatically programmed.

MANUAL CHECK OF " SWING" OR TEMPERATURE DIFFERENTIAL

The operation of the factory set "THERMO SWING" can be checked by adjusting the SET TEMP 2° F above or below the room temperature. This will cause the system to turn ON or OFF. Normally the system will only respond to temperature changes every two minutes. Manually changing the SET temperature will activate the system in less than 10 seconds. IF the "SWING" is changed, then a new room temperature differential will respond. Factory setting of "SWING" temperature is 2° F.

SETTING THE COUNTDOWN TIMER

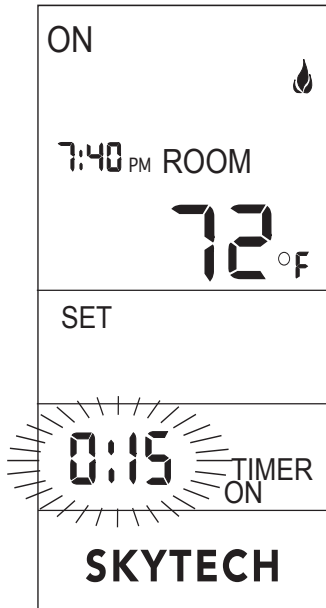

This remote control system can operate with a built-in countdown timer when the transmitter is in the ON or THERMO modes (THERMO or ON must be displayed on the screen).

1. Touch the word **TIMER** on the LCD screen of the transmitter for more than two seconds on the transmitter. The minimum 0:15 minute setting on the will begin to flash.
2. Press the UP or DOWN button on the transmitter to begin advancing through each of the countdown time options. Available countdown times are 15 minutes, 30 minutes, 45 minutes, 1 hour, 1 hour 30 minutes, 2 hours, 2 hours 30 minutes, and each additional half-hour up to nine hours.
3. To set the **TIMER** press the **MODE/SET** button on the transmitter if the system is ON. It will remain on until the time has expired. If the system is in the THERMO mode, it will cycle ON and OFF, as the room temperature requires until the “time” has expired.

OPERATIONAL NOTE: When the timer is used in the THERMO mode, the THERMO operation will discontinue when the “time” has expired. System will return to the THERMO OFF position.

LOW/BATTERY INDICATOR

The battery **ICON** on the right side of the LCD screen will appear when battery power has dropped significantly. At this time, approximately two weeks of battery power remains until the transmitter may experience partial or complete loss of functions.

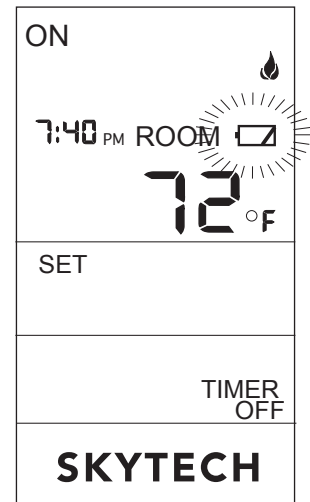

CHILDPROOF “LOCK-OUT” – (CP)

This remote control includes a CHILDPROOF “LOCK-OUT” feature that allows the user to “LOCK-OUT” operation of the appliance from the TRANSMITTER.

SETTING “LOCK-OUT” – (CP)

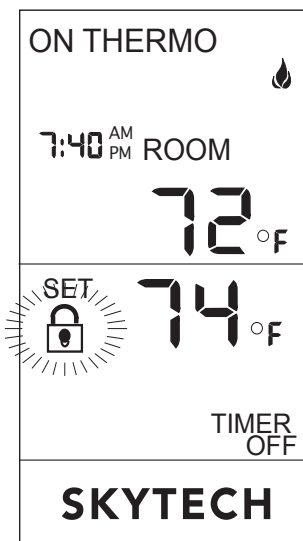

1. To activate the “LOCK-OUT” feature, press and hold the UP button and touch the word **TIMER** on the LCD screen of the transmitter together, for 5 seconds. The lock icon will appear on the LCD screen.
2. To disengage the “LOCK-OUT”, press and hold the UP button and touch the word **TIMER** on the LCD screen of the transmitter together for 5 seconds or more, and the lock icon will disappear from the LCD screen and the transmitter will return to its normal operating condition.

NOTE: If the appliance is already operating in the ON or THERMO MODES, engaging the “LOCK-OUT” will not cancel the operating MODE. Engaging the “LOCK-OUT” prevents only the manual operation of the TRANSMITTER. If in the auto modes, the THERMO operation will continue to operate normally. To totally “LOCK-OUT” the operation of the TRANSMITTER’S operating signals; the transmitter’s MODE must be set to OFF.

TRANSMITTER

The remote control operates, on RF (radio frequency) signals that are sent by the TRANSMITTER (remote) to the RECEIVER that operates the appliance. It is recommended that the TRANSMITTER always be located within the 20-foot operating range, preferably in the same room in which the appliance is located.

THERMO UPDATING FEATURE – TRANSMITTER – (T/S – TX)

This SKYTECH remote control has a THERMO UPDATING Feature built into its software. The THERMO UPDATING Feature operates in the following manner, but only in the THERMO MODES:

The transmitter normally reads the ROOM temperature every 2 minutes checking the ROOM temperature against the SET temperature and then sends a signal to the receiver.

COMMUNICATION – SAFETY – TRANSMITTER – (C/S – TX)

This remote control has a COMMUNICATION – SAFETY function built into its software. It provides an extra margin of safety when the TRANSMITTER is out of the normal 20-foot operating range of the receiver.

The COMMUNICATION – SAFETY feature operates in the following manner, in all OPERATING MODES – ON/ ON THERMO/ ON TIMER.

At all times and in all OPERATING MODES, the transmitter sends an RF signal every fifteen (15) minutes, to the receiver, indicating that the transmitter is within the normal operating range of 20-feet. Should the receiver NOT receive a transmitter signal every 15 minutes, the IC software, in the RECEIVER, will begin a 2-HOUR (120-minute) countdown timing function. If during this 2-hour period, the receiver does not receive a signal from the transmitter, the receiver will shut down the appliance being controlled by the receiver. The RECEIVER will then emit a series of rapid “beeps” for a period of 10 seconds. Then after 10 seconds of rapid beeping, the RECEIVER will continue to emit a single “beep” every 4 seconds until a transmitter MODE button is pressed to reset the receiver. The intermittent 4-second beeping will go on for as long as the receiver’s batteries last which could be in excess of one year.

To “reset” the RECEIVER and operate the appliance, on the 5301 there two (2) methods (1) press the MODE/SET button or (2) press the top of the LCD screen on the transmitter. The word ON must display on the LCD screen. By turning the system to ON, the COMMUNICATION – SAFETY operation is overridden and the system will return to normal operation depending on the MODE selected at the transmitter. The COMMUNICATION – SAFETY feature will reactivate should the transmitter be taken out of the normal operating range or should the transmitter’s batteries fail or be removed.

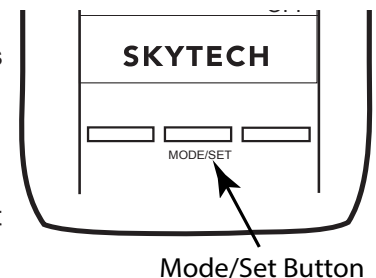

REMOTE RECEIVER

The remote receiver operates on (4) AA-size 1.5V batteries. SEE DRAWING ON PAGE 6. It is recommended that ALKALINE batteries be used for longer battery life and maximum microprocessor performance. **IMPORTANT:** New or fully charged batteries are essential for proper operation of the remote receiver.

The remote receiver houses the microprocessor that responds to commands from the transmitter to control system operation. It emits one beep when it receives an ON or OFF command manually, but no beep when cycling ON and OFF automatically in THERMO mode. The remote receiver has a 3-position slide switch for selecting the MODE of operation: ON/REMOTE/OFF

- With the slide switch in the ON position (toward the LEARN button), the system will remain on until the slide switch is placed in the OFF or REMOTE position.
- With the slide switch in the REMOTE position (centered), the system will only operate if the remote receiver receives commands from the transmitter.
- With the slide switch in the OFF position (away from the LEARN button), the system is OFF.
- **It is suggested that the slide switch be placed in the off position if you will be away from your home for an extended period of time. If the remote receiver is mounted out of children’s reach, placing the slide switch in the OFF position also functions as a safety “lock-out” by both turning the system off and rendering the remote receiver inoperative.**

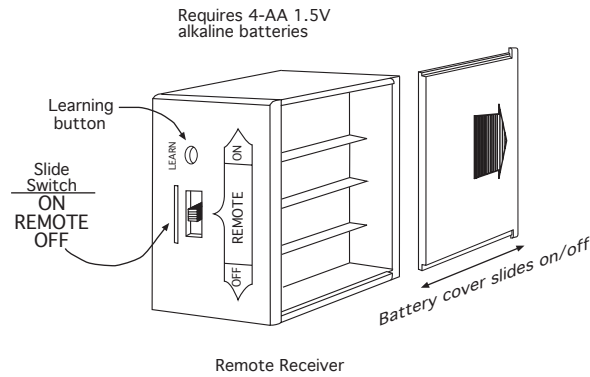

THERMO- SAFETY FEATURE – RECEIVER (T/S –RX)

This remote control has a THERMO- SAFETY feature that is built into the system’s RECEIVER. This feature is temperature- activated and provides an extra margin of safety when the RECEIVER is operating where ambient temperatures exceed 130°F degrees inside the receiver case.

The THERMO-SAFETY feature, in the RECEIVER, operates in the following manner, when the appliance is in operation.

The receiver is thermally protected from extreme heat conditions. Heat can have negative effect on the operation of the receiver’s microprocessors.

For REMOTE RECEIVERS that operate on BATTERY POWER, these heat conditions can cause batteries to discharge when temperatures exceed 115°F. Studies show that alkaline batteries, when exposed to a constant temperature of 120° F, can lose up to 50% of their operating power. When the battery cools down, it will partially recharge itself, but constant heating and cooling will reduce the battery’s normal life expectancy.

When the ambient temperature at the THERMISTOR, inside the receiver case, reaches 130° F, the THERMISTOR will automatically shut the appliance down and the RECEIVER will begin emitting a series of 4 “beeps”, every 2 seconds. When the ambient temperature, at the RECEIVER, drops between 120° F and 130° F, the user can reactivate the appliance by pushing the MODE button on the transmitter. The word ON must display on the LCD screen. When the MODE button is pressed to ON, the THERMISTOR “resets” itself and the fireplace will begin operating again. However, the “beeping” will continue, if the ambient temperature remains between 120° F and 130° F. This “beeping” alerts the user that the RECEIVER should be repositioned so the ambient temperature drops below 120° F.

When the temperature drops below 120° F, the “beeping” will cease, providing the user has “reset” the THERMISTOR by pushing the MODE button to ON to operate the appliance, either manually or thermally. Allow sufficient time for the receiver to cool below 120° F, and then press MODE button to stop beeping.

INSTALLATION INSTRUCTIONS

WARNING

This remote control system must be installed exactly as outlined in these instructions. Read all instructions completely before attempting installation. Follow instructions carefully during installation. Any modifications of the SKYTECH remote control or any of its components will void the warranty and may be pose a fire hazard.

Do not connect any gas valve or electronic module directly to 110-120VAC power. Consult gas appliance manufacturer’s instructions and wiring schematics for proper placement of all wires. All electronic modules are to be wired to manufacturer’s specifications.

The following wiring diagrams are for illustration purpose only. Follow instructions from manufacturer of gas valve and/or electronic module for correct wiring procedures. Improper installation of electric components can cause damage to electronic module, gas valve and remote receiver.

INSTALLATION

The remote receiver can be either wall-mounted in a standard plastic switch box or placed on or near the fireplace hearth. Preferably, the remote receiver should be wall-mounted in a plastic switch box, as this will protect its electronic components from both the heat produced by the gas appliance and potential damage or abuse that can occur if it is left exposed on the hearth. **PROTECTION FROM EXTREME HEAT IS VERY IMPORTANT.** Like any piece of electronic equipment, the remote receiver should be kept away from temperatures exceeding 130°F inside the receiver case. Battery life is also significantly shortened if batteries are exposed to high temperatures.

Make sure the remote receiver switch is in the OFF position. It is recommended that 18 gauge stranded or solid wires (included) be used to make connections between the terminal wiring block on the millivolt gas valve or electronic module and the wire terminals on the remote receiver. For the best results, use 18 gauge stranded or solid wire, with no splices and measuring no longer than 20-feet.

WALL MOUNTING

Install (4) AA-size 1.5 ALKALINE batteries in the remote receiver. For best performance, remote receiver batteries should be factory fresh when installed. Very little battery power is required to operate the remote receiver, but the electronics are tuned to operate best when battery output is greater than 5.3 volts. Four new AA batteries should provide an output voltage of 6.0 to 6.2 volts. Be sure batteries are installed with the (+) and (-) ends facing the correct direction.

To attach wall cover plate to receiver box:

- Position the receiver as shown in diagram to the right with lower tab on wall cover plate into groove of receiver (Make sure the LEARN hole on cover plate properly aligns with remote receiver)
- Pull receiver up and snap into top tab of cover plate.
- Position the wall cover plate so the word ON is facing up.
- Install the remote receiver into the plastic switch box using the two long screws provided. Push the slide Button over the receiver slide switch only after making sure the remote receiver has LEARNED the transmitter's security code (see LEARNING TRANSMITTER TO RECEIVER). **NOTE:** Slide button covers the Learn hole when properly installed.

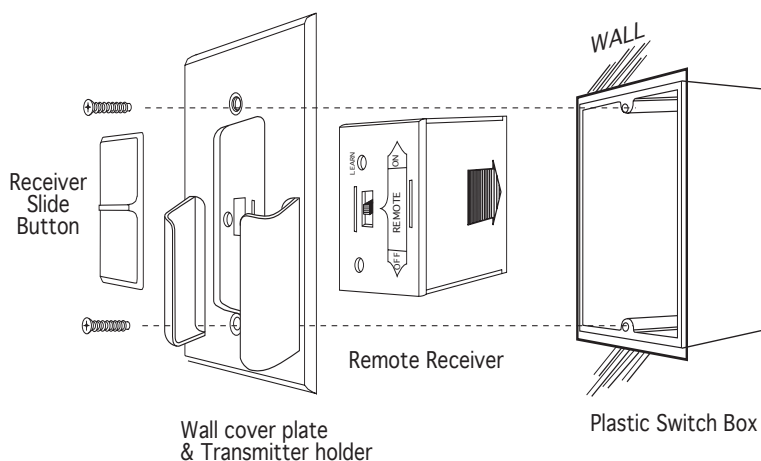
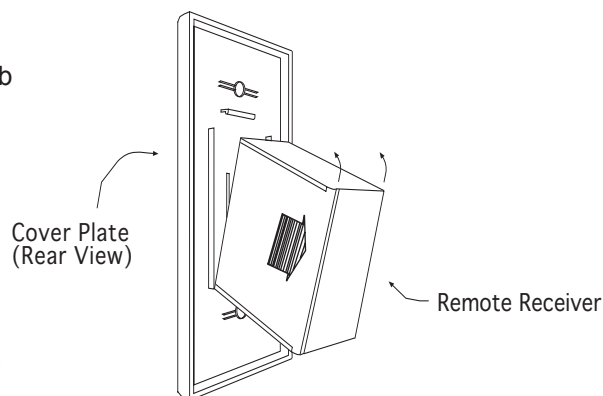

NOTE: The remote receiver will only respond to the transmitter when the 3-position slide button on the remote receiver is in the REMOTE position. If the system does not respond to the battery transmitter on initial use, see LEARNING TRANSMITTER TO RECEIVER, and recheck battery positions in the remote receiver.

NOTE: The remote receiver will only respond to the transmitter when the 3-position slide button on the remote receiver is in the REMOTE position. If the system does not respond to the battery transmitter on initial use, see **LEARNING TRANSMITTER TO RECEIVER**, and recheck battery positions in the remote receiver.

HEARTH MOUNT

The remote receiver can be placed on the fireplace hearth or under the fireplace, behind the control access panel. Position where the ambient temperature inside the receiver case does not exceed 130°F.

NOTE: Black Slide Button is used for Hearth Mount applications.

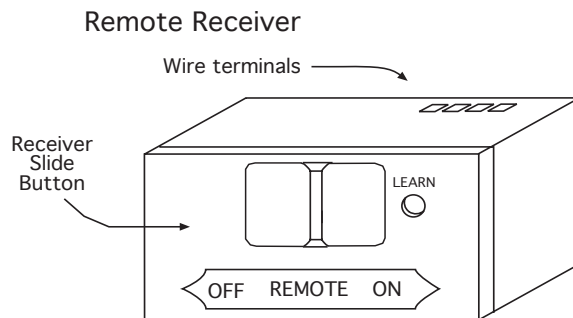

WIRING INSTRUCTIONS

A qualified electrician or a gas technician who is familiar with the gas appliance and gas valves that will be operated by this remote should install the remote control system. Incorrect wiring connections WILL cause damage to the gas valve or electronic module operating the gas appliance and may also damage the remote receiver.

WIRING MILLIVOLT VALVES

The remote receiver is connected to the millivolt valve using the TH (thermostat) terminals on the terminal block on the millivolt gas valve. Connect 18 gauge stranded or solid wires from the remote receiver to the gas valve.

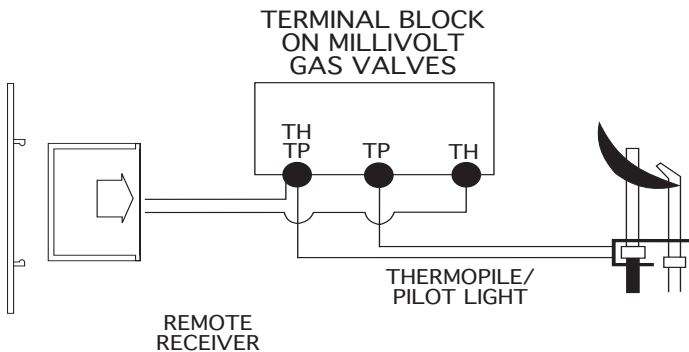

Operation of the remote receiver is similar to that of a thermostat in that both turn the gas valve ON and OFF based on input signals. A thermostat's input signals are different temperatures. The remote receiver's input signals come from the transmitter.

Connect each of the two wires leading from the TH and TH/TP terminals on the millivolt gas valve to either of the two wire terminals on the remote receiver. Normally it does not matter which wires go to which terminal.

WIRING ELECTRONIC SPARK IGNITIONS

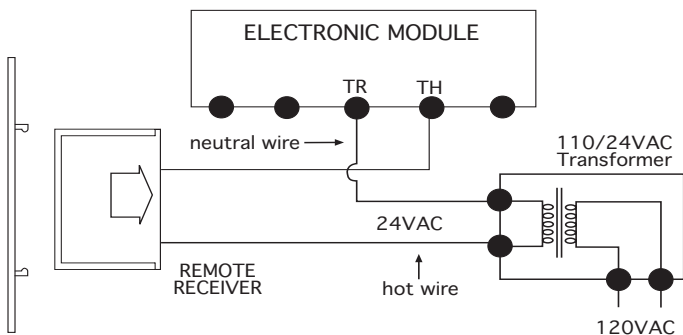

The remote control receiver can be connected, in series, to a 24VAC transformer to the TR (transformer) terminal on the ELECTRONIC MODULE. Connect the hot wire from the 24VAC transformer to either of the wire terminals on the remote receiver. Connect another wire between the other receiver wire terminal and the TH (thermostat) terminal on the ELECTRONIC MODULE.

SYSTEM CHECK

MILLIVOLT VALVES

Light your gas appliance following the lighting instructions that came with the appliance. Confirm that the pilot flame is ON; it must be in operation for the main gas valve to operate.

- Slide the 3-position button on the remote receiver to the ON position. The main gas flame (i.e., the fire) should ignite.
- Slide the button to OFF. The flame should extinguish (the pilot flame will remain on).
- Slide the button to REMOTE (the center position), and then press the MODE button on the transmitter to change the system to ON. The main gas flame should ignite.
- Press the MODE/SET button on the transmitter to change the system to OFF. The flame should extinguish (the pilot flame will remain on).
- Press the MODE/SET button on the transmitter to change the system to THERMO. Advance the SET temperature on the transmitter to a temperature of at least 2°F (1°C) above the ROOM temperature displayed on the LCD screen. With this manual setting, the normal thermostatic cycle is overridden and the system flame will ignite. Set the SET temperature to at least 2°F (1°C) below the room temperature and the system flame will extinguish in a few seconds. Thereafter, it should continue to cycle to on and off thermostatically approximately every two minutes as the ROOM temperature changes, but only when the temperature differential between ROOM and SET temperatures differ at least 2°F (1°C). The 2°F differential is the factory setting.

ELECTRONIC IGNITION SYSTEMS

- Slide the 3-position button on the remote receiver to the ON position. The spark electrode should begin sparking to ignite the pilot (the pilot may ignite after only one spark). After the pilot flame is lit, the main gas valve should open and the main gas flame should ignite.
- Slide the button to OFF. The main gas flame and pilot flame should BOTH extinguish.
- Slide the button to REMOTE (the center position), and then press the MODE button on the transmitter to change the system to ON. The spark electrode should begin sparking to ignite the pilot. After the pilot is lit, the main gas valve should open and the main gas flame should ignite.
- Press the MODE/SET button on the transmitter to OFF. The main gas flame and pilot flame should BOTH extinguish.
- Press the MODE/SET button on the transmitter to change the system to THERMO. Advance the SET temperature on the transmitter to a temperature of at least 2°F (1°C) above the ROOM temperature displayed on the LCD screen. With this manual setting the normal thermostatic cycle is overridden and the system flame will ignite. Set the SET temperature to at least 2°F (1°C) below the room temperature and the system flame will extinguish in a few seconds. Thereafter, it should continue to cycle to on and off thermostatically approximately every two minutes as the ROOM temperature changes, but only when the temperature differential between ROOM and SET temperatures differ at least 2°F (1°C). (The 2°F differential is the factory setting).

TIMER

The countdown timer will operate in either the manual ON or THERMO mode. Once the appliance is in an operating mode, set the countdown timer to turn OFF in 15 minutes. The timer function will allow operation to continue until the countdown "time" on the LCD screen expires. After 15 minutes elapses, the system should turn OFF.

If you have any problems with operation, recheck you connections and ensure transmitter batteries are fully charged. If no problem is found, contact the dealer where you purchased your appliance/remote control.

GENERAL INFORMATION

LEARNING TRANSMITTER TO RECEIVER

Each transmitter uses a unique security code. It will be necessary to press the LEARN button on the receiver to accept the transmitter security code upon initial use, if batteries are replaced, or if a replacement transmitter is purchased from your dealer or the factory. In order for the receiver to accept the transmitter security code, be sure the slide button on the receiver is in the REMOTE position; the receiver will not LEARN if the slide switch is in the ON or OFF position. The LEARN button is located on the front face of the receiver; inside the small hole labeled LEARN. Using a small screwdriver or end of a paper clip gently press and release the black LEARN button inside the hole. When you release the LEARN button the receiver will emit an audible "beep". After the receiver emits the beep press the transmitter MODE/SET button and release. The receiver will emit several beeps indicating that the transmitter's code has been accepted into the receiver.

The microprocessor that controls the security code matching procedure is controlled by a timing function. If you are unsuccessful in matching the security code on the first attempt, wait 1-2 minutes before trying again – this delay allows the microprocessor to reset its timer circuitry – and try up to two or three more times.

THERMO FUNCTION

When the transmitter is in the THERMO mode, it should be kept away from direct sources of heat such as fireplaces, incandescent lighting, and direct sunlight. Leaving the transmitter in direct sunlight, for example, will cause its heat-sensing diode to read the room temperature higher than it actually is; if in THERMO mode, it may not turn on the appliance even if the ambient ROOM temperature is below the SET temperature.

BATTERY LIFE

Life expectancy of alkaline batteries in the SKYTECH 5301 should be at least 12 months. Check and replace all batteries annually. When the Transmitter no longer operates the receiver from a distance it did previously (i.e., the transmitter's range has decreased) or the remote receiver does not function at all, the batteries should be checked. It is important that the remote receiver batteries are fully charged, providing a combined output voltage of at least 5.3 volts. The length of the wire between the remote receiver and the gas valve directly affects the operating performance of the remote system. The longer the wire, the more battery power is required to deliver signals between the remote receiver and the gas valve. The Transmitter should operate with as little as 5.0 volts of battery power, measuring at the (4) 1.5-volt batteries.

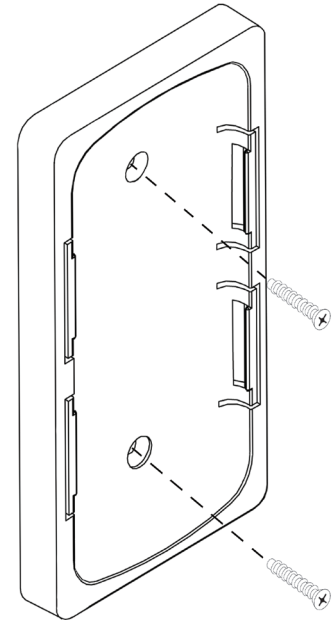

TRANSMITTER WALL MOUNT

The transmitter can be placed on a wall using the mount provided. Wood - Drill 1/8" pilot holes and install with screws provided. Plaster/Wallboard - Drill 1/4" holes, use a hammer to tap in the two plastic anchors. Then install with the screws provided.

TROUBLE SHOOTING

Should you encounter problems with your fireplace system, the problem may be with the fireplace itself or it could be with the SKYTECH remote control. Review the fireplace manufacturer's operation manual to make sure all connections are properly made. Then check the operation of the SKYTECH remote in the following manner:

1. Make sure receiver batteries are installed properly. If one battery is installed backward, receiver will not operate in remote mode. Be sure battery output is 5.0 volts or more. (Slide switch is independent of battery condition.)
2. Be sure the transmitter's batteries are properly installed and that the battery output is 5.0 V or more.
3. Check to make sure the transmitter is communicating with the receiver.
 - If the receiver beeps when the MODE button is depressed on the transmitter they are communicating.
 - If the receiver does not beep when the MODE/SET button is depressed on the transmitter, you will need to teach the receiver the code of the transmitter. This is done by holding the LEARN button down on the receiver (**NOTE:** Slide Button, White or Black, covers the LEARN access hole when installed), and at the same time depress the MODE/SET button on the transmitter. A change in the beeping pattern, at the receiver indicates the transmitter's code has been programmed into the receiver.
4. Make sure the transmitter is within the 15 to 20-foot range of the receiver.
5. Positioning of the receiver is important. If the receiver is "enclosed" in a metal surround, the operation of the receiver may be affected as noted below. Reposition the receiver to improve operating range. It is suggested that a heat shield be installed to protect the receiver from extreme heat. If the receiver is "enclosed" in a metal surround, this can:
 - Cause the RF signal to get lost and not communicate with the receiver.
 - Cause the working distance to be shorter than normal.

NOTE: A receiver located in an area, where the ambient temperature inside the case exceeds 130°F, will cause THERMO-SAFETY feature to cut in, requiring you to reposition the receiver to stop the warning beeps, and to "reset" the receiver's operation.

SPECIFICATIONS

BATTERIES: Transmitter 6V- 4 ea. AAA 1.5V, Alkaline
Remote Receiver 6V – 4ea. AA 1.5 Alkaline
Operating Frequency: 303.8MHZ

FCC REQUIREMENTS

NOTE: THE MANUFACTURER IS NOT RESPONSIBLE FOR ANY RADIO OR TV INTERFERENCE CAUSED BY UNAUTHORIZED MODIFICATIONS TO THE EQUIPMENT. SUCH MODIFICATIONS COULD VOID THE USER'S AUTHORITY TO OPERATE THE EQUIPMENT

Federal Communication Commission Interference Statement

This equipment has been tested and found to comply with the limits for a Class B digital device, pursuant to Part 15 of the FCC Rules.

These limits are designed to provide reasonable protection against harmful interference in a residential installation. This equipment generates, uses, and can radiate radio frequency energy and, if not installed and used in accordance with the instructions, may cause harmful interference to radio communications. However, there is no guarantee that interference will not occur in a particular installation.

If this equipment does cause harmful interference to radio or television reception, which can be determined by turning the equipment off and on, the user is encouraged to try to correct the interference by one or more of the following measures:

- Reorient or relocate the receiving antenna.
- Increase the separation between the equipment and receiver.
- Connect the equipment into an outlet on a circuit different from that to which the receiver is connected.
- Consult the dealer or an experienced radio/TV technician for help.

This device complies with Industry Canada license - exempt RSS standard(s).

Operation is subject to the following two conditions:

- (1) This device may not cause interference, and
- (2) This device must accept any interference, including interference that may cause undesired operation of the device.

Cet appareil est conforme aux normes RSS exemptes de licence d'Industrie Canada.

Le fonctionnement est soumis aux deux conditions suivantes:

- (1) Cet appareil ne doit pas causer d'interférences et
- (2) Cet appareil doit accepter toute interférence, y compris les interférences pouvant entraîner un fonctionnement indésirable de l'appareil.

This device complies with RSS 210 of Industry Canada. This Class B device meets all the requirements of the Canadian interferencecausing equipment regulations.

Cet appareil est conforme à la norme RSS 210 d'Industrie Canada. Cet appareil de classe B respecte toutes les exigences du règlement canadien sur le matériel brouilleur.

LIMITED WARRANTY

1. **Limited Warranty.** Skytech II, Inc. (“Skytech”) warrants that each new Skytech Remote Control System, including all hardware, parts and components (the “System”), when used in accordance with the instructions furnished by Skytech provided with each System, shall be free in all material respects of defects in material and workmanship, subject to proper installment and normal use (the “Warranty”). The Warranty extends only to the original retail purchaser of the System (the “Customer”), is not transferable, and expires upon any sale or transfer of the System by the Customer.
2. **System Sold As Is.** Subject to this Warranty and any applicable state law, each System is sold by Skytech to a Customer on an “as is” basis. In addition, each System and Skytech’s obligations are and remain subject to all additional disclaimers, limitations, reservations of rights, exclusions, and qualifications set forth on Skytech’s website, www.skytechpg.com, all of which are considered part of the Warranty and are incorporated herein (collectively, the “Additional Terms”). Each Customer, by purchasing and/or using any System or any portion thereof, does so subject to the Warranty and the Additional Terms.
3. **Repair or Replacement of System or Parts.** Should any System, or any hardware, components and/or parts contained therein fail due to a defect in workmanship or material provided by Skytech after the purchase of a System by a Customer, Skytech shall repair or, at its option, replace the defective System or part, hardware, or component, subject to the Customer’s compliance with all terms and conditions contained herein governing service and claims under the Warranty. Skytech shall provide replacement parts at no charge for the first (5) five years of this warranty, and at market cost for the Lifetime of the product to the Customer. Gas valve and gas valve components will be available at no charge for one (1) year. If Skytech does not have the parts for an individual model, then a replacement System will be provided at no charge within the first (5) five years after purchase, and then at market cost for the Lifetime of that product to the Customer.
4. **Warranty Claims; Skytech Service.** To submit a valid claim under the Warranty (each, a “Valid Claim”), a Customer must comply with the following:
 - (a) Provide written notice to a Skytech or an Authorized Dealer (“Dealer”) and provide the Name, Address and Telephone Number of the Customer.
 - (b) Describe the System model number and nature of the defect, nonconformity, or other problem with the System;
 - (c) Provide such notice within thirty (30) days of discovery of such defect, nonconformity, or problem;
 - (d) Obtain a Return Merchandise Authorization (“RMA”) number from Skytech by calling (855) 498-8324; and
 - (e) Securely pack and ship the defective System to Skytech at 9230 Conservation Way, Fort Wayne, IN 46809, at the Customer’s cost, within thirty (30) days from the date Skytech issued the RMA to the Customer with the RMA number clearly marked on the outside of the box containing the returned System.

Any shipment that does not meet all the Valid Claim requirements may be refused by Skytech. Skytech is not responsible for any refused shipments, or any damage caused due to shipping, whether or not it was a Valid Claim. Skytech shall be responsible for return shipment charges for any System returned should Skytech determine there is no defect with the System, reject for failure of the Customer to submit a Valid Claim, or otherwise determine is not eligible for service under the Warranty.

Upon receipt of a Valid Claim and the properly returned System, Skytech shall, at its option, either (a) repair the System, at no charge to the Customer, or (b) replace the returned System with a new System, at no charge to the Customer, or (c) provide the Customer with a refund in an amount equal to the price paid by the Customer for the defective System. Any System or hardware, component or part repaired by Skytech hereunder, or any replacement System, hardware, component or part shall be shipped to the Customer by Skytech at Skytech’s cost and the Warranty, the Additional Terms, and all other terms and conditions set forth herein shall extend to such repaired or replacement System, hardware, component or part. No refund shall be paid by Skytech before the defective System, hardware, component and/or part are received by Skytech from the Customer. Any obligation of Skytech under this Section 4 shall be and remain subject to Skytech’s right to physically inspect the defective System, hardware, component and/or part returned to Skytech by the Customer.

5. Some States do not allow the exclusion or limitation of incidental and consequential damages or limitation on how long an implied warranty lasts, so the above limitation may not apply to you. This warranty gives you specific rights and you may have other rights, which vary from state, province, or nation. To the extent allowable under any law, the liability of Skytech is limited to the express terms of this warranty, and Skytech expressly disclaims all implied warranties, including any warranties of fitness for a particular purpose or merchantability.

How to Obtain Service:

In addition to the foregoing, contact Skytech or your Skytech Dealer direct with the following information:

- Name, Address, Telephone Number of Customer
- Date of Purchase, Proof of Purchase
- Model Name, Date Code of Product, and any relevant information or circumstances, concerning installation, mode of operation and/or when defect was noted

Warranty claim process will start with all this information. Skytech reserves the right to physically inspect the product for defects, by authorized representatives.

Print information below and return form to:

Skytech Products Group, 9230 Conservation Way,
Fort Wayne, IN. 46809; Attn. Warranty Dept
Phone: (855) 498-8224

Warranty Information

Purchase Date: _____ Model: _____ Date Code: _____

Note: Date code may be in one of two formats -

(1) Printed 4-digit number: YYMM format. Example: 2111 = 2021, November

(2) Check box with date code marked: 2-year boxes and 1-12 month box format. Example:

21'	<input checked="" type="checkbox"/>	1	2	3	4	5	6
22'	<input type="checkbox"/>	7	8	9	10	11	12

= 2021, November

Purchased From: _____

Customer Name: _____ Phone: _____

Address: _____

City: _____ State/Prov. _____ Zip/Postal Code _____

E-mail Address: _____

Please send a "Proof of Purchase" (original receipt) copy along with your warranty form.

**FOR TECHNICAL
SERVICE, CALL:**

U.S. INQUIRIES
(855) 498-8324 or (260) 459-1703

CANADIAN INQUIRIES
(877) 472-3923

Skytech Products Group
9230 Conservation Way
Fort Wayne, IN 46809
Sales Support: (888) 699-6167
Website: www.skytechpg.com

MANUFACTURED EXCLUSIVELY FOR SKYTECH II, INC

