

eurofit

FURNITURE FITTINGS

SHORT ARM GAS LIFT STAY



APPLICATION



SET INCLUDES

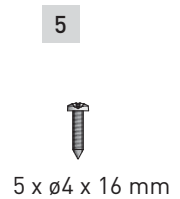
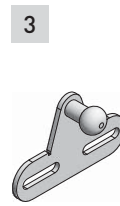
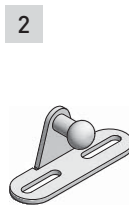
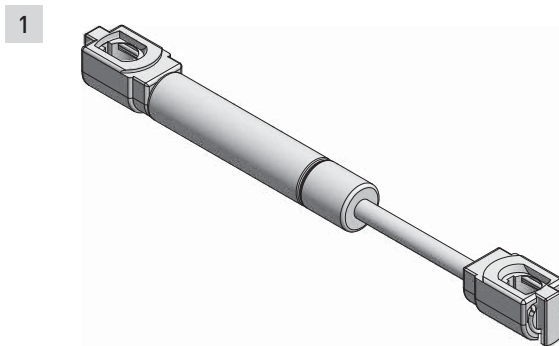

1. Damper
2. Front connector (full front)
3. Front connector (aluminium frame)
4. Mounting to the body
5. Mounting screws

PLANNING

Cabinet planning information

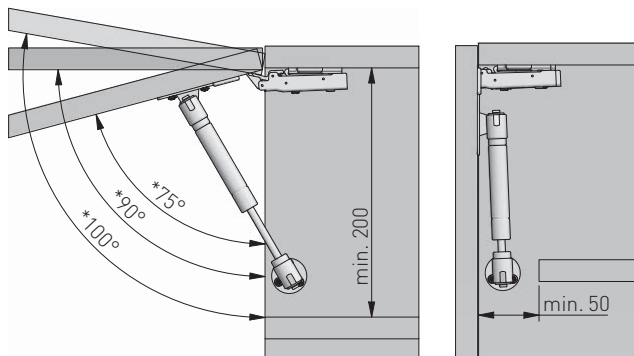

* approximate angle depending on the hinge used

Spacing of mounting holes in the body and on front

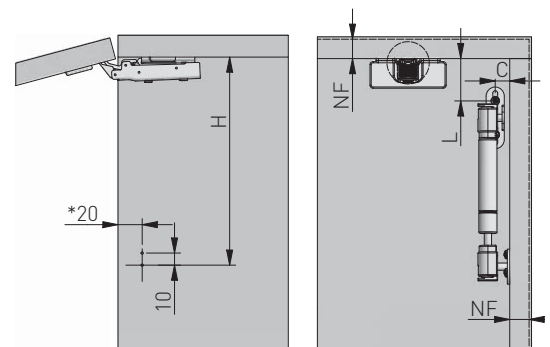

* for inset door hinges = 20 + GF

Cabinet planning information

Spacing of mounting holes in the body and on front

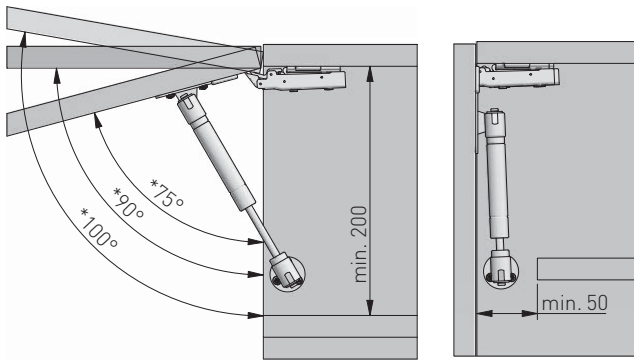

* approximate angle depending on the hinge used

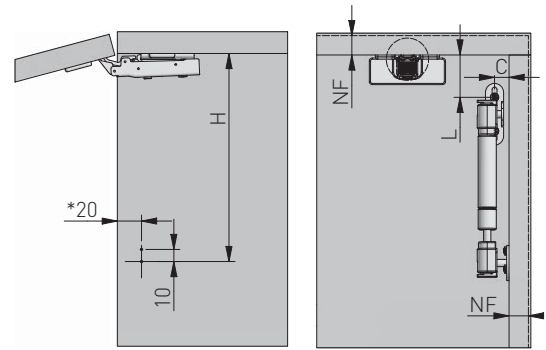

* for inset door hinges = 20 + GF

Door opening angle	Inset door			Twin door			Overlay door		
	H (mm)	L (mm)	C (mm)	H (mm)	L (mm)	C (mm)	H (mm)	L (mm)	C (mm)
75°	188	50	12 - s (2-3 mm)	180	50	12	172	50	12
90°	176	41		167	41		160	41	
100°	172	37		164	36		154	36	

Door opening angle	Lift force	Door height (mm)			
		300	400	500	600
75°	60 N	2,0	1,5	1,2	1,0
	80 N	2,7	2,0	1,6	1,4
90°	60 N	1,8	1,3	1,1	0,9
	80 N	2,4	1,8	1,4	1,2
100°	60 N	1,6	1,2	0,9	0,8
	80 N	2,1	1,6	1,2	1,0

Product dimensions

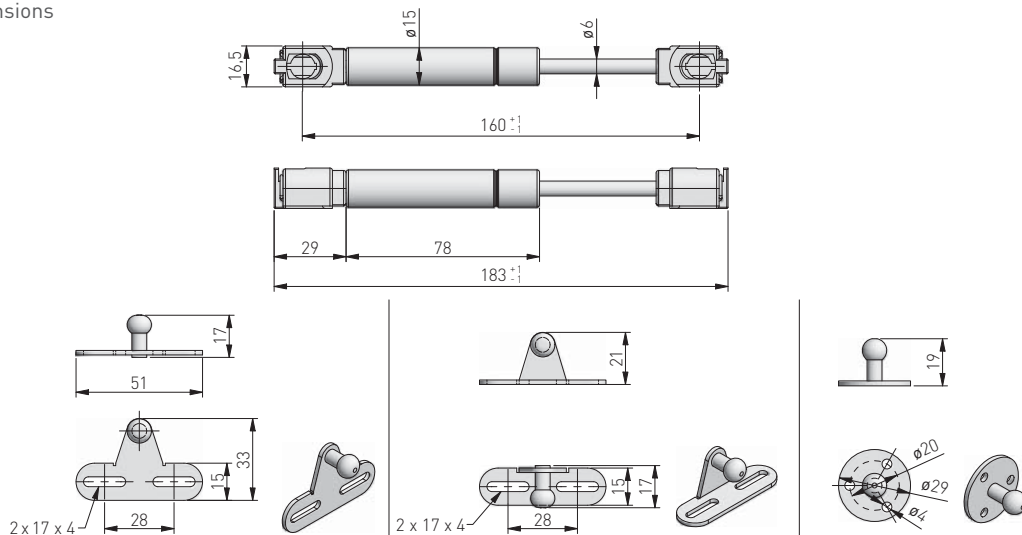

ASSEMBLY

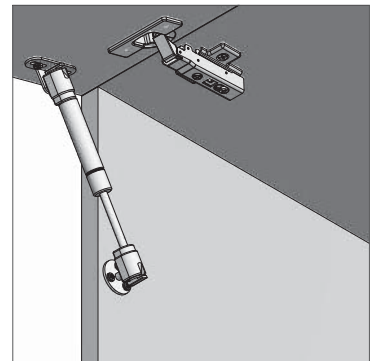
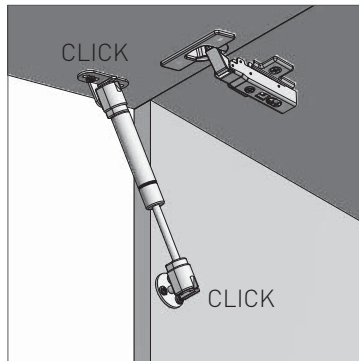
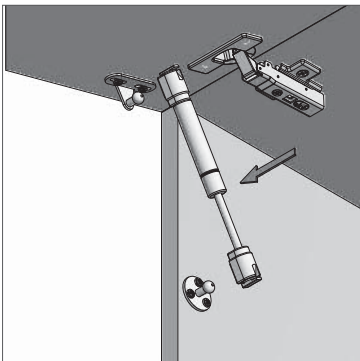
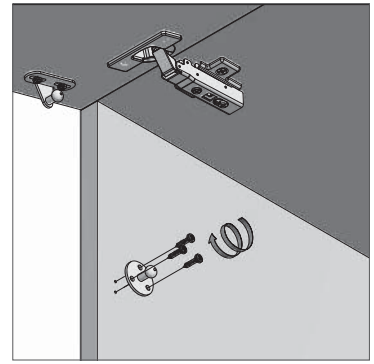
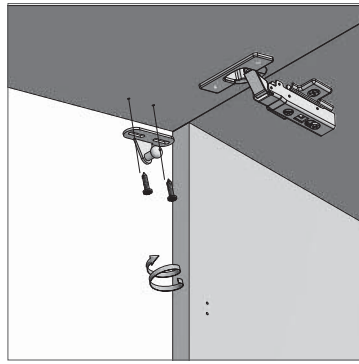
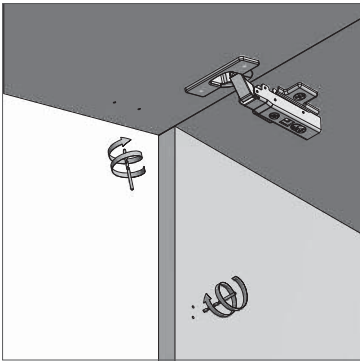

OPENING ANGLE ADJUSTMENT

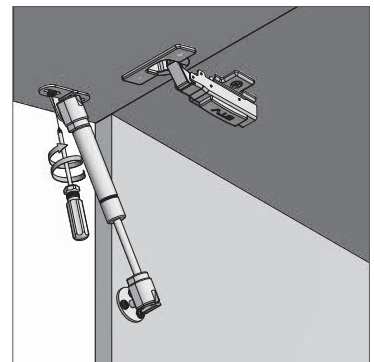
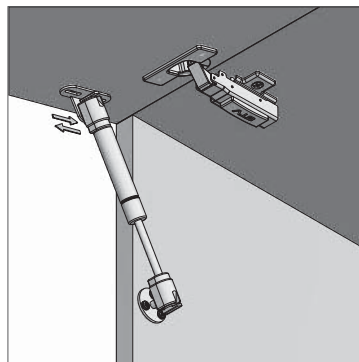
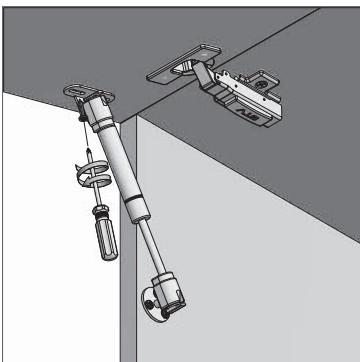

REMOVAL

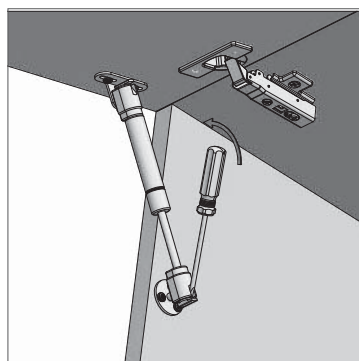
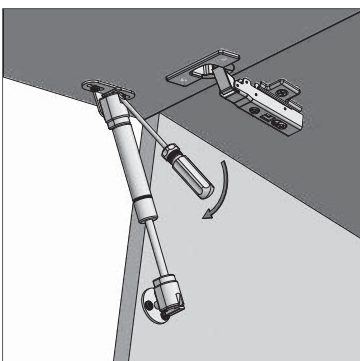

REMOVAL

