

Sanicompact® Comfort PART N° 020



CONNECTIONS

- Discharge: 1"
- Inlet: 1-1/4"

Designed with an internal one-way vent built which eliminates the need to have an external vent pipe

PRODUCT FEATURES

- Install a half bathroom up to 9 feet below the sewer line, or even up to 120 feet away.
- Self-contained macerating system for residential applications.
- The blade is made out of a hardened stainless steel material which eliminates the need for any service or replacement.

PUMP CURVE

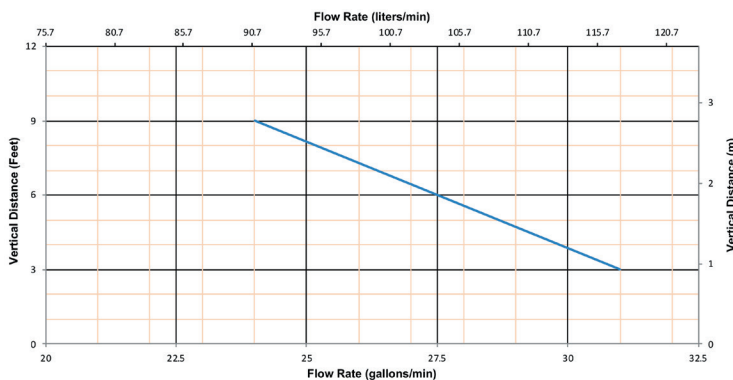

OPTIONAL ACCESSORIES

Descaler
(Part N° 052)
See page 28



TECHNICAL SPECIFICATIONS

Pump type: Macerator

Electrical: 120 V - 60 Hz / 7.2 Amps (Max)

Motor: 0.5 HP oil-filled thermally protected motor

Capacitor rating: 45 microfarad

Operating Temperature: 95°F (110°F Max.)

Power cord length: 59 inches

Noise level: ≤ 53 dBA (Lp) (measured at 3 ft.)

Discharge pipe diameter: 1"

Discharge rate at 9 ft: 24 GPM

Discharge rate at 3 ft: 31 GPM

Normal running time: 24 sec (18 sec ECO mode)

Capacity: 0.8 gallons / 0.3 liters

Inlets: 1-1/4" sink connection (on motor case)

Method of activation: Push button / circuit board

Weight: 72 lbs / 32.7 kg (Bowl with motor)

Certifying agencies: CSA (IPC, NSPC)

Connections: Sink

DIMENSIONAL DRAWINGS

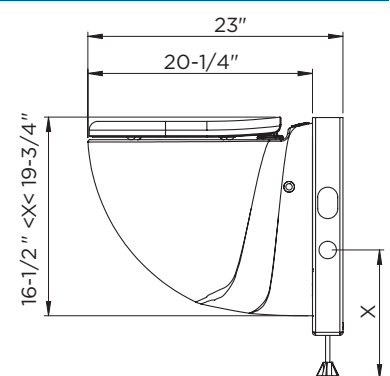
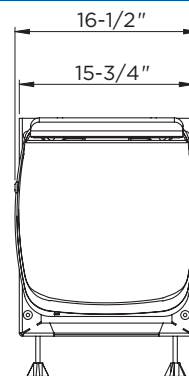

* Carrier included